

## High voltage fast-switching NPN power transistors

### Features

- High voltage capability
- Low spread of dynamic parameters
- Minimum lot-to-lot spread for reliable operation
- Very high switching speed

### Applications

- Electronic ballast for fluorescent lighting
- Switch mode power supplies.

### Description

The devices are manufactured using high voltage multi-epitaxial planar technology for high switching speeds and high voltage capability.

Thanks to an increased intermediate layer, it has an intrinsic ruggedness which enables the transistor to withstand an high collector current level during breakdown condition, without using the transil protection usually necessary in typical converters for lamp ballast.

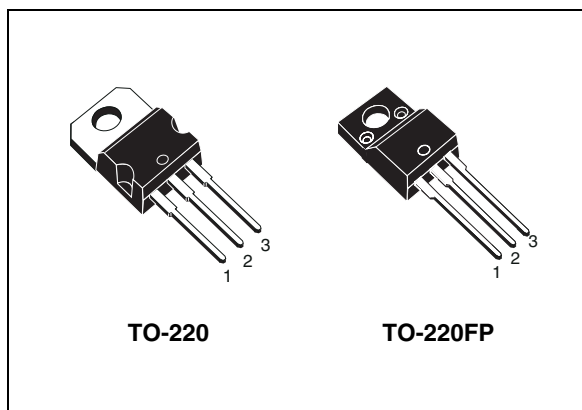

Figure 1. Internal schematic diagram

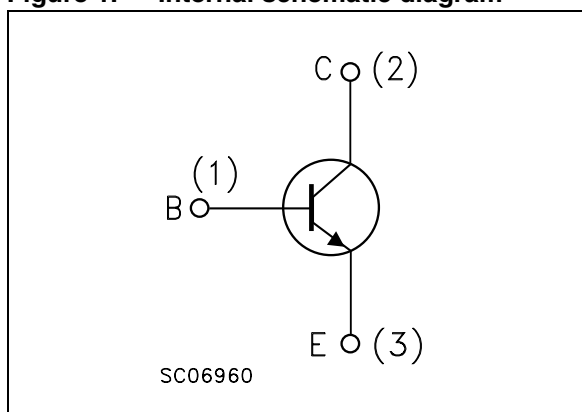

Table 1. Device summary

Order codes	Marking	Packages	Packaging
BUL741	BUL741	TO-220	Tube
BUL741FP	BUL741FP	TO-220FP	Tube

## Contents

<b>1</b>	<b>Electrical ratings</b> .....	<b>3</b>
<b>2</b>	<b>Electrical characteristics</b> .....	<b>4</b>
	2.1 Typical characteristic .....	4
	2.2 Test circuits .....	7
<b>3</b>	<b>Package mechanical data</b> .....	<b>8</b>
<b>4</b>	<b>Revision history</b> .....	<b>11</b>

# 1 Electrical ratings

**Table 2. Absolute maximum rating**

Symbol	Parameter	Value	Unit
$V_{CES}$	Collector-emitter voltage ( $V_{BE} = 0$ )	1050	V
$V_{CEO}$	Collector-emitter voltage ( $I_B = 0$ )	400	V
$V_{EBO}$	Emitter-base voltage ( $I_C = 0$ , $I_B = 2$ A, $t_P < 10$ ms)	$V_{(BR)EBO}$	V
$I_C$	Collector current	2.5	A
$I_{CM}$	Collector peak current ( $t_P < 5$ ms)	5	A
$I_B$	Base current	1.5	A
$I_{BM}$	Base peak current ( $t_P < 5$ ms)	3	A
$P_{tot}$	Total dissipation at $T_C = 25$ °C for TO-220	60	W
	Total dissipation at $T_C = 25$ °C for TO-220FP	30	
$T_{stg}$	Storage temperature	-65 to 150	°C
$T_J$	Max. operating junction temperature	150	°C

**Table 3. Thermal data**

Symbol	Parameter	TO-220	TO-220FP	Unit
$R_{thJC}$	Thermal resistance junction-case max	2.08	4.17	°C/W

## 2 Electrical characteristics

$T_{case} = 25\text{ }^{\circ}\text{C}$  unless otherwise specified.

**Table 4. Electrical characteristics**

Symbol	Parameter	Test conditions	Min.	Typ.	Max.	Unit
$I_{CES}$	Collector cut-off current ( $V_{BE} = 0$ )	$V_{CE} = 1050\text{ V}$		0.2	10	$\mu\text{A}$
$I_{CEO}$	Collector cut-off current ( $I_B = 0$ )	$V_{CE} = 400\text{ V}$		10	250	$\mu\text{A}$
$V_{(BR)EBO}$	Emitter-base breakdown voltage ( $I_C = 0$ )	$I_E = 1\text{ mA}$	15	19	24	V
$V_{CEO(sus)}^{(1)}$	Collector-emitter sustaining voltage ( $I_B = 0$ )	$I_C = 10\text{ mA}$	400	450		V
$V_{CE(sat)}^{(1)}$	Collector-emitter saturation voltage	$I_C = 0.7\text{ A}$ $I_B = 0.14\text{ A}$ $I_C = 2\text{ A}$ $I_B = 0.6\text{ A}$		0.15 0.5	0.5 1.5	V V
$V_{BE(sat)}^{(1)}$	Base-emitter saturation voltage	$I_C = 2\text{ A}$ $I_B = 0.6\text{ A}$		1.1	1.5	V
$h_{FE}$	DC current gain	$I_C = 0.1\text{ A}$ $V_{CE} = 5\text{ V}$ $I_C = 0.45\text{ A}$ $V_{CE} = 3\text{ V}$	48 25	70 35	100 50	
$t_s$ $t_f$	Resistive load Storage time Fall time	$V_{CC} = 125\text{ V}$ $I_C = 1\text{ A}$ $I_{B(on)} = -I_{B(off)} = 0.2\text{ A}$ $t_p = 300\text{ }\mu\text{s}$ $V_{BB(off)} = -5\text{ V}$		2.5 350	3.5 500	$\mu\text{s}$ ns
$E_{ar}$	Repetitive avalanche energy	$L = 2\text{ mH}$ $C = 1.8\text{ nF}$ $V_{BB(off)} = -5\text{ V}$	5			mJ

1. Pulse test: pulse duration  $\leq 300\text{ }\mu\text{s}$ , duty cycle  $\leq 2\%$

### 2.1 Typical characteristic

**Figure 2. Safe operating area**

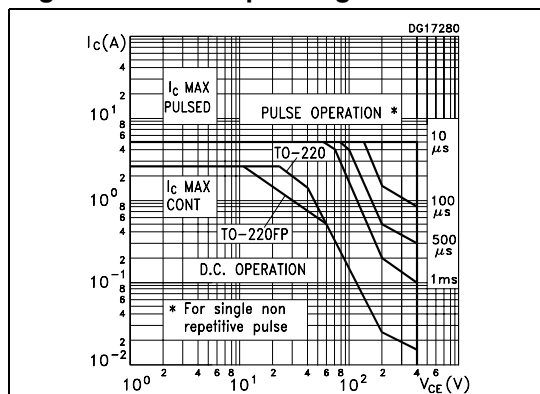

**Figure 3. Derating curve**

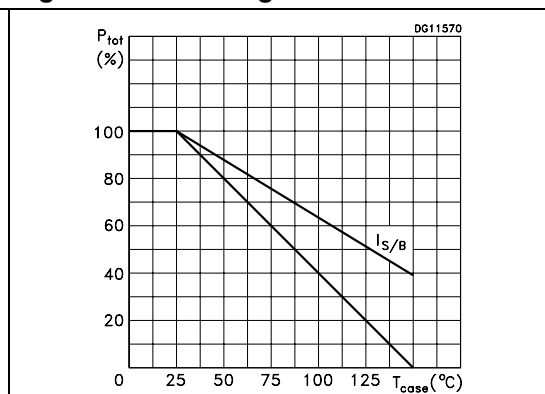

Figure 4. Output characteristics

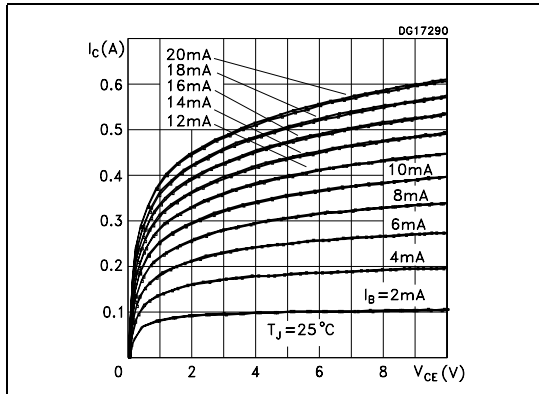

Figure 5. Reverse biased safe operating area

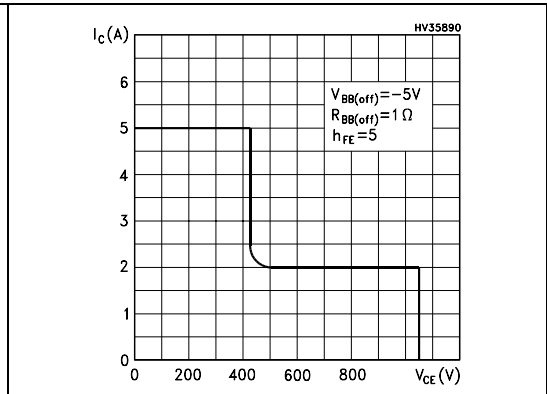

Figure 6. DC current gain ( $V_{CE} = 3\text{ V}$ )

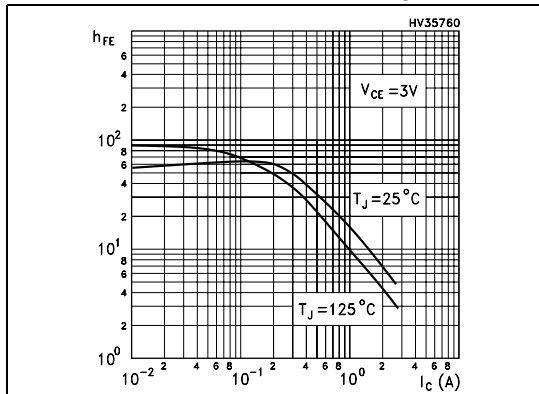

Figure 7. DC current gain ( $V_{CE} = 5\text{ V}$ )

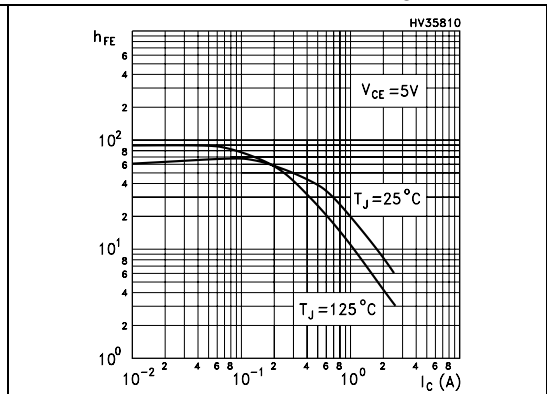

Figure 8. Base-emitter saturation voltage

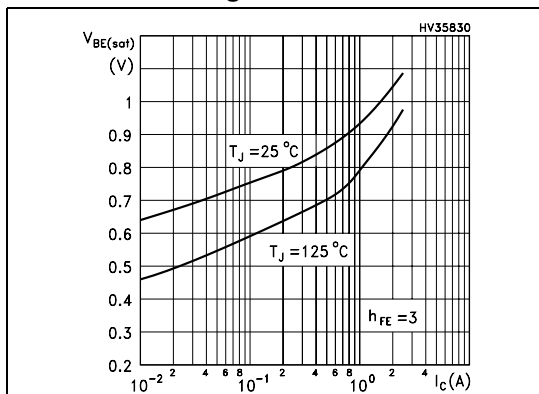

Figure 9. Collector-emitter saturation voltage

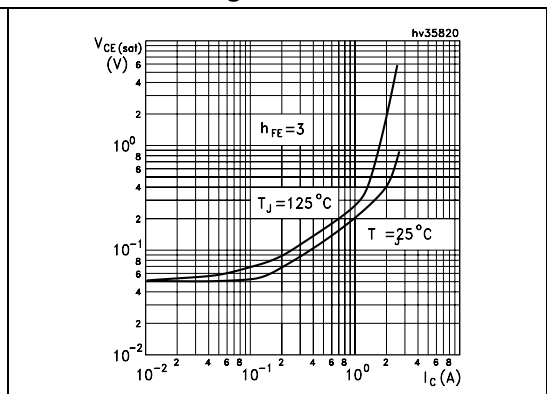

Figure 10. Resistive load switching on ( $h_{FE} = 5$ )

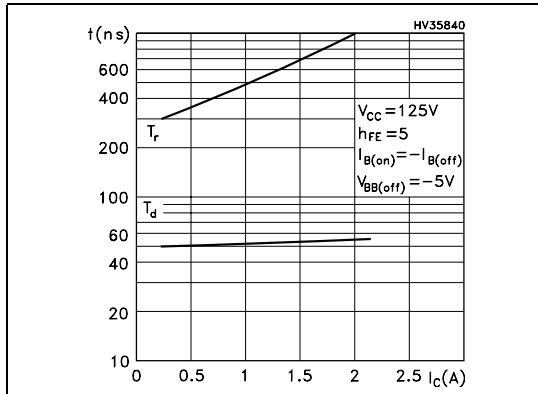

Figure 11. Resistive load switching on ( $h_{FE} = 10$ )

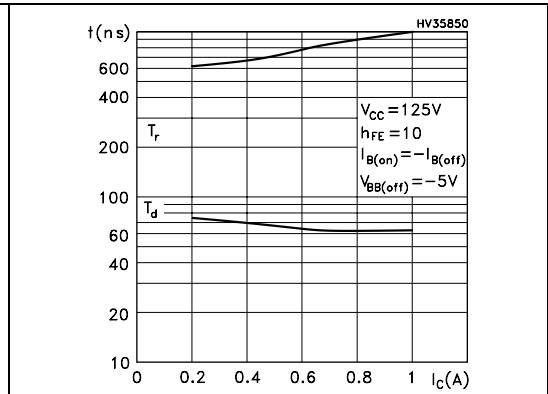

Figure 12. Resistive load switching off ( $h_{FE} = 5$ )

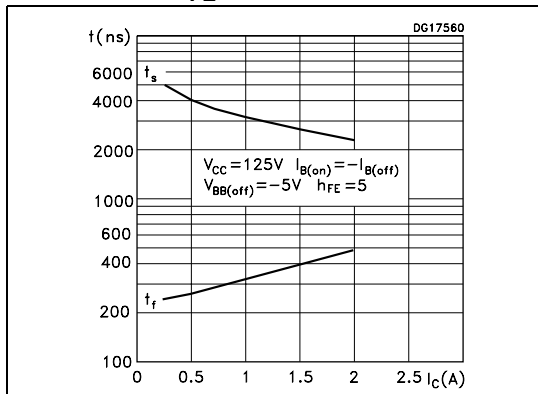
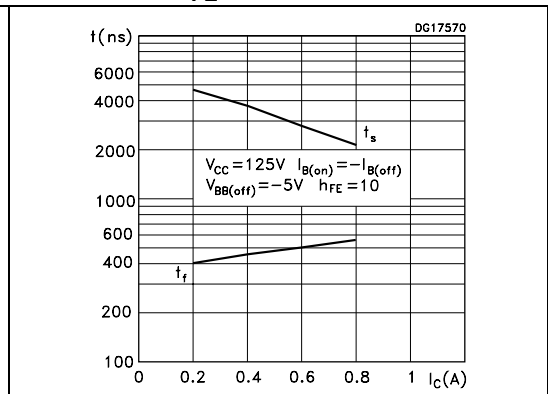
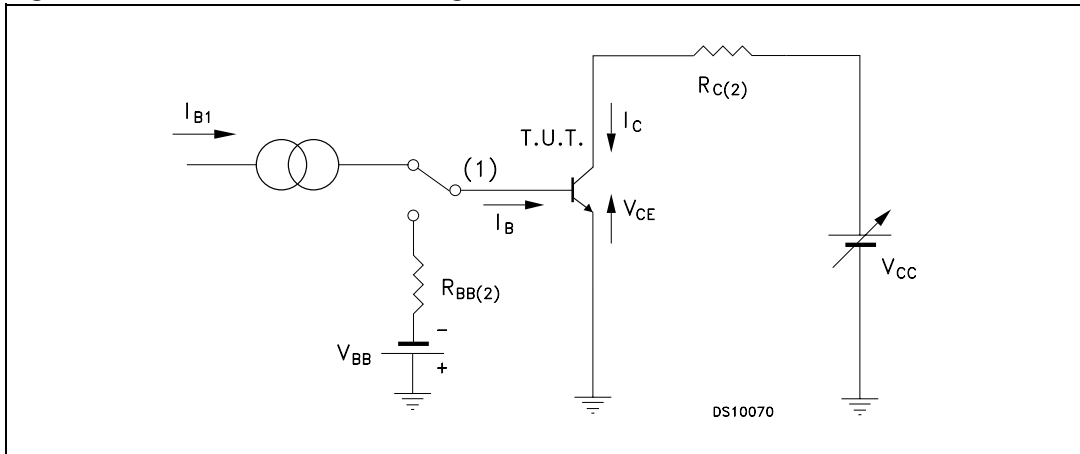

Figure 13. Resistive load switching off ( $h_{FE} = 10$ )



## 2.2 Test circuits

Figure 14. Resistive load switching test circuit



1. Fast electronic switch
2. Non-inductive resistor

Figure 15. Energy rating test circuit

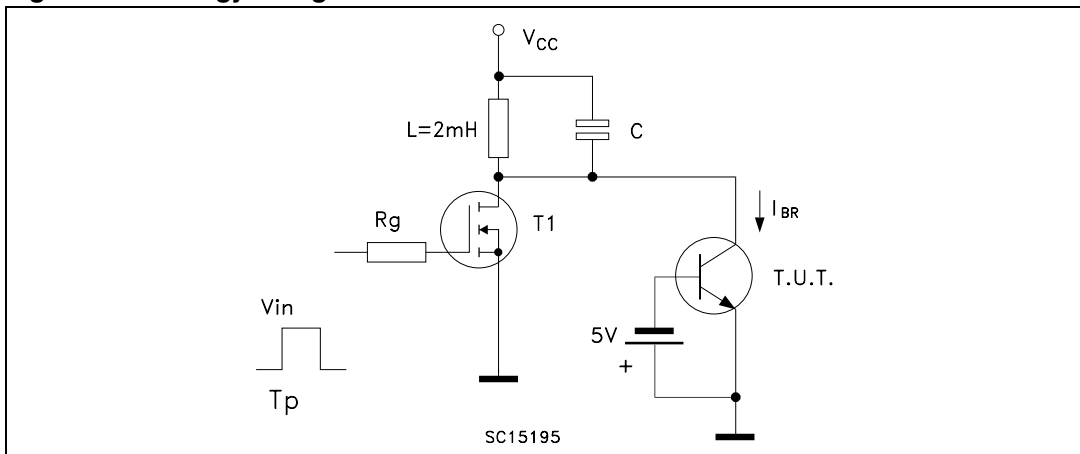

### 3 Package mechanical data

In order to meet environmental requirements, ST offers these devices in different grades of ECOPACK<sup>®</sup> packages, depending on their level of environmental compliance. ECOPACK<sup>®</sup> specifications, grade definitions and product status are available at: [www.st.com](http://www.st.com). ECOPACK<sup>®</sup> is an ST trademark.

TO-220 type A mechanical data

Dim	mm		
	Min	Typ	Max
A	4.40		4.60
b	0.61		0.88
b1	1.14		1.70
c	0.48		0.70
D	15.25		15.75
D1		1.27	
E	10		10.40
e	2.40		2.70
e1	4.95		5.15
F	1.23		1.32
H1	6.20		6.60
J1	2.40		2.72
L	13		14
L1	3.50		3.93
L20		16.40	
L30		28.90	
∅P	3.75		3.85
Q	2.65		2.95

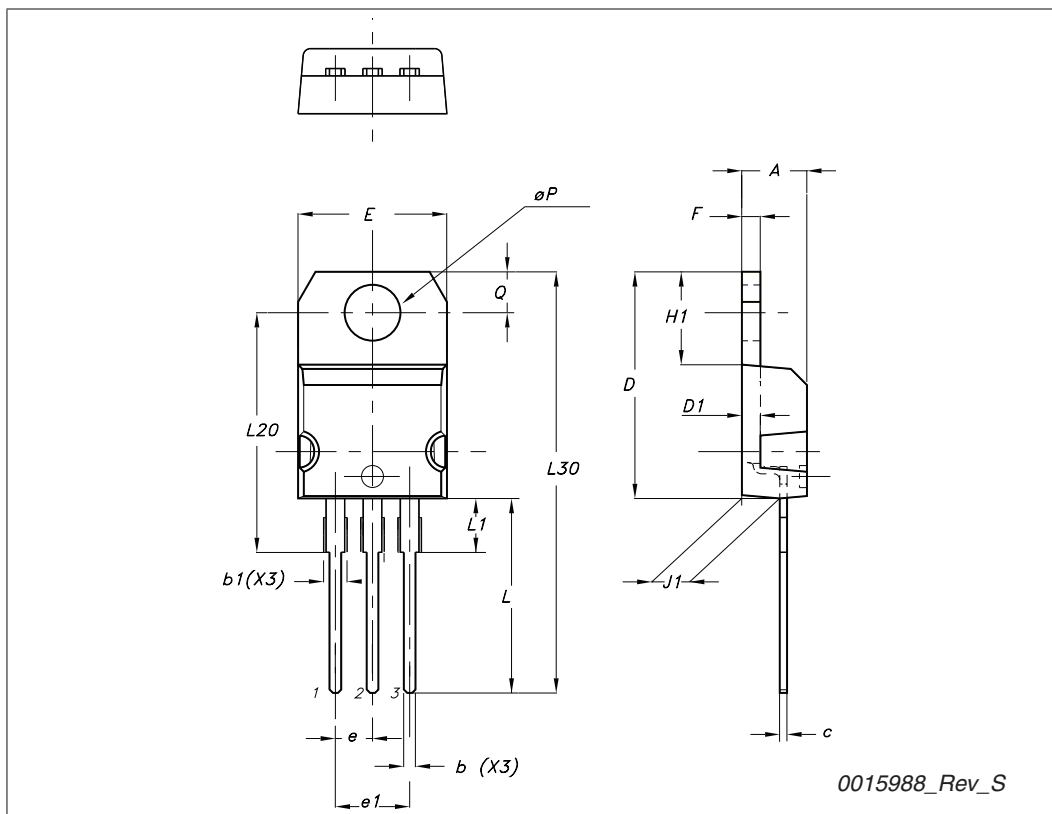

TO-220FP mechanical data

Dim.	mm		
	Min.	Typ.	Max.
A	4.4		4.6
B	2.5		2.7
D	2.5		2.75
E	0.45		0.7
F	0.75		1
F1	1.15		1.70
F2	1.15		1.5
G	4.95		5.2
G1	2.4		2.7
H	10		10.4
L2		16	
L3	28.6		30.6
L4	9.8		10.6
L5	2.9		3.6
L6	15.9		16.4
L7	9		9.3
Dia	3		3.2

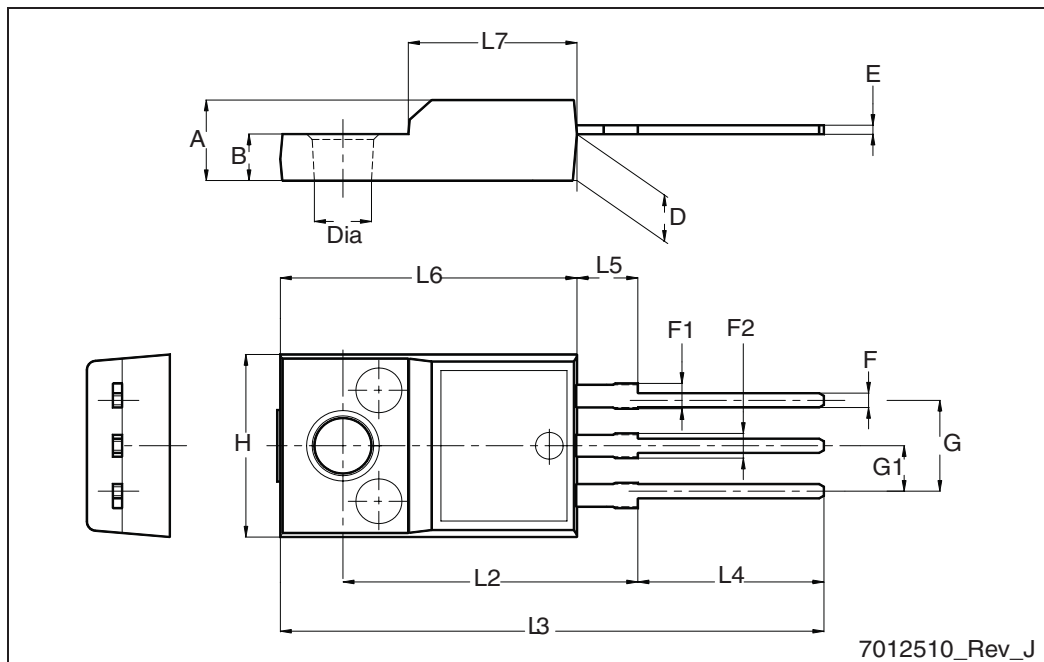

## 4 Revision history

**Table 5. Document revision history**

Date	Revision	Changes
11-Apr-2007	1	Initial release.
10-Jul-2007	2	Figure 12 and 13 have been updated.
18-Aug-2009	3	Added new package TO-220FP and mechanical data.

**Please Read Carefully:**

Information in this document is provided solely in connection with ST products. STMicroelectronics NV and its subsidiaries ("ST") reserve the right to make changes, corrections, modifications or improvements, to this document, and the products and services described herein at any time, without notice.

All ST products are sold pursuant to ST's terms and conditions of sale.

Purchasers are solely responsible for the choice, selection and use of the ST products and services described herein, and ST assumes no liability whatsoever relating to the choice, selection or use of the ST products and services described herein.

No license, express or implied, by estoppel or otherwise, to any intellectual property rights is granted under this document. If any part of this document refers to any third party products or services it shall not be deemed a license grant by ST for the use of such third party products or services, or any intellectual property contained therein or considered as a warranty covering the use in any manner whatsoever of such third party products or services or any intellectual property contained therein.

**UNLESS OTHERWISE SET FORTH IN ST'S TERMS AND CONDITIONS OF SALE ST DISCLAIMS ANY EXPRESS OR IMPLIED WARRANTY WITH RESPECT TO THE USE AND/OR SALE OF ST PRODUCTS INCLUDING WITHOUT LIMITATION IMPLIED WARRANTIES OF MERCHANTABILITY, FITNESS FOR A PARTICULAR PURPOSE (AND THEIR EQUIVALENTS UNDER THE LAWS OF ANY JURISDICTION), OR INFRINGEMENT OF ANY PATENT, COPYRIGHT OR OTHER INTELLECTUAL PROPERTY RIGHT.**

**UNLESS EXPRESSLY APPROVED IN WRITING BY AN AUTHORIZED ST REPRESENTATIVE, ST PRODUCTS ARE NOT RECOMMENDED, AUTHORIZED OR WARRANTED FOR USE IN MILITARY, AIR CRAFT, SPACE, LIFE SAVING, OR LIFE SUSTAINING APPLICATIONS, NOR IN PRODUCTS OR SYSTEMS WHERE FAILURE OR MALFUNCTION MAY RESULT IN PERSONAL INJURY, DEATH, OR SEVERE PROPERTY OR ENVIRONMENTAL DAMAGE. ST PRODUCTS WHICH ARE NOT SPECIFIED AS "AUTOMOTIVE GRADE" MAY ONLY BE USED IN AUTOMOTIVE APPLICATIONS AT USER'S OWN RISK.**

Resale of ST products with provisions different from the statements and/or technical features set forth in this document shall immediately void any warranty granted by ST for the ST product or service described herein and shall not create or extend in any manner whatsoever, any liability of ST.

ST and the ST logo are trademarks or registered trademarks of ST in various countries.

Information in this document supersedes and replaces all information previously supplied.

The ST logo is a registered trademark of STMicroelectronics. All other names are the property of their respective owners.

© 2009 STMicroelectronics - All rights reserved

STMicroelectronics group of companies

Australia - Belgium - Brazil - Canada - China - Czech Republic - Finland - France - Germany - Hong Kong - India - Israel - Italy - Japan - Malaysia - Malta - Morocco - Philippines - Singapore - Spain - Sweden - Switzerland - United Kingdom - United States of America

[www.st.com](http://www.st.com)