

4-BIT DUAL SUPPLY BUS BUFFER LEVEL TRANSLATOR WITH A SIDE SERIES RESISTOR

- HIGH SPEED: $t_{PD} = 4.4ns$ (MAX.) at $T_A=85^\circ C$
 $V_{CCB} = 1.65V$; $V_{CCA} = 3.0V$
- LOW POWER DISSIPATION:
 $I_{CCA} = I_{CCB} = 5\mu A$ (MAX.) at $T_A=85^\circ C$
- SYMMETRICAL OUTPUT IMPEDANCE:
 $|I_{OHA}| = I_{OLA} = 10mA$ MIN at
 $V_{CCA} = 3.0V$; $V_{CCB} = 1.4V$ to $3.6V$
 $|I_{OHA}| = I_{OLA} = 8mA$ MIN at
 $V_{CCA} = 2.3V$; $V_{CCB} = 1.4$ to $3.6V$
- BALANCED PROPAGATION DELAYS:
 $t_{PLH} \cong t_{PHL}$
- POWER DOWN PROTECTION ON INPUTS AND OUTPUTS
- 26Ω SERIES RESISTOR ON A SIDE OUTPUTS
- OPERATING VOLTAGE RANGE:
 $V_{CCA}(OPR) = 1.4V$ to $3.6V$ (1.2V Data Retent)
 $V_{CCB}(OPR) = 1.4V$ to $3.6V$ (1.2V Data Retent)
- MAX DATA RATES:
 380 Mbps (1.8V to 3.3V translation)
 260 Mbps (<1.8V to 3.3V translation)
 260 Mbps (Translate to 2.5V)
 210 Mbps (Translate to 1.5V)
 100 Mbps (Translate to 1.2V)
- LATCH-UP PERFORMANCE EXCEEDS 500mA (JESD 17)
- ESD PERFORMANCE:
 HBM > 2000V (MIL STD 883 method 3015);
 MM > 200V
- RoHS Compliant for FLIPCHIP Package

DESCRIPTION

The ST4G3234 is a dual supply low voltage CMOS 4-BIT BUS BUFFER level translator fabricated with sub-micron silicon gate and five-layer metal wiring C²MOS technology. Designed for use as an interface between a 3.3V bus and a 2.5V or 1.8V bus in a mixed 3.3V/1.8V, 3.3V/2.5V, 1.8V/1.4V and 2.5V/1.8V supply systems, it achieves high speed operation while maintaining the CMOS low power dissipation.

This IC is intended for one-way asynchronous communication between data buses. The input and output power down protections disable the device when both power supply are down, so that the buses are effectively isolated.

The input tolerant buffers allow to translate V_{CCB} compatible signals and greater signals than V_{CCB} up/down to V_{CCA} .

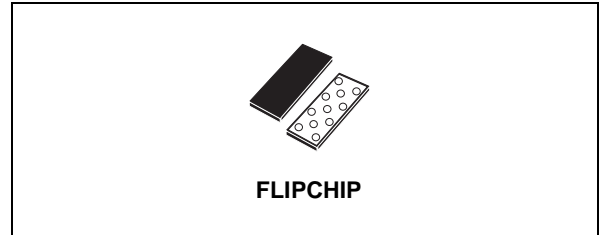

Table 1: Order Codes

PACKAGE	T & R	Comments
FLIPCHIP11	ST4G3234BJR	5000 parts per reel

All inputs are equipped with protection circuits against static discharge, giving them ESD immunity and transient excess voltage.

Figure 1: Logic Diagram

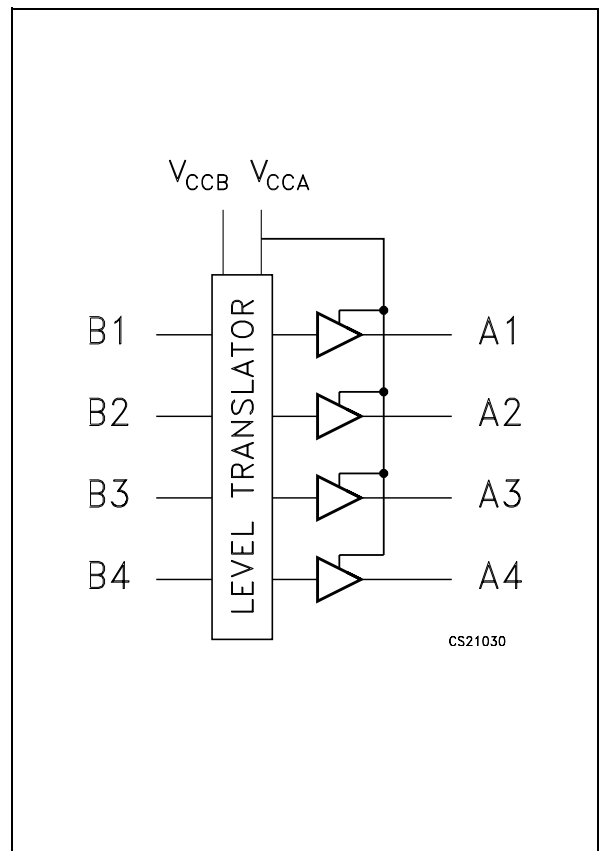

Figure 2: Input And Output Equivalent Circuit

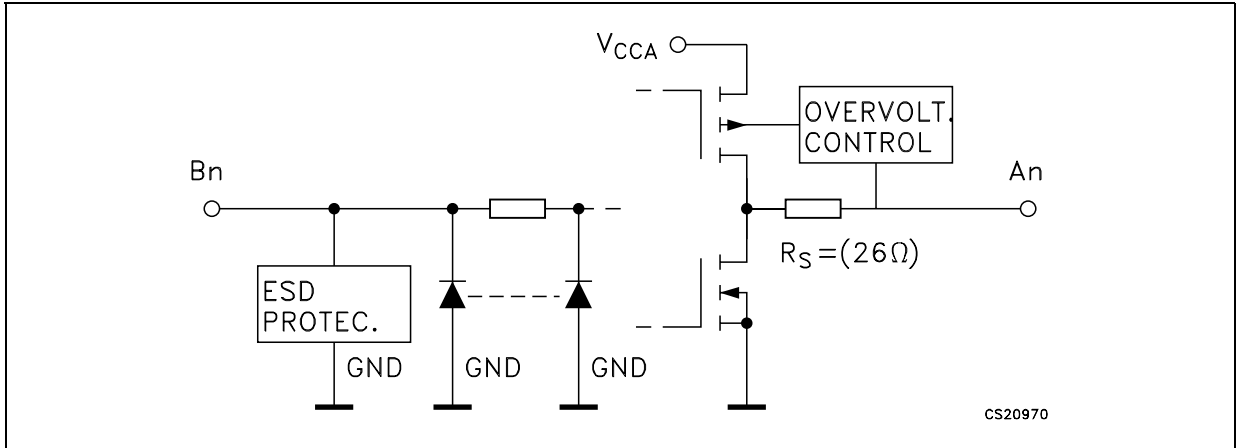

Table 2: Pin Description

PIN°	SYMBOL	NAME AND FUNCTION
A1	A4	Data Output
A3	A3	Data Output
A5	A2	Data Output
A7	A1	Data Output
C1	B4	Data Input
C3	B3	Data Input
C5	B2	Data Input
C7	B1	Data Input
B2	GND	Ground (0V)
B6	V _{CCA}	Positive Supply Voltage
B4	V _{CCB}	Positive Supply Voltage

Figure 3: Pin Connection (top through view)

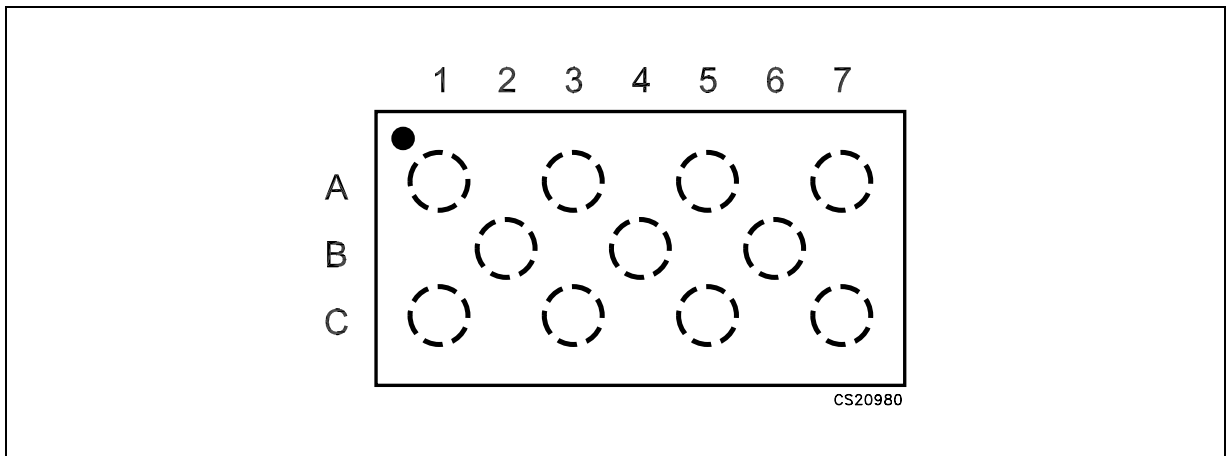

Table 3: Truth Table

INPUTS Bn (V_{CCB} Referred)	OUTPUTS Bn (V_{CCA} Referred)
L	L
H	H

Table 4: Absolute Maximum Ratings

Symbol	Parameter	Value	Unit
V_{CCA}	Output Supply Voltage	-0.5 to +4.6	V
V_{CCB}	Input Supply Voltage	-0.5 to +4.6	V
V_{OA}	DC Output Voltage (Power Down Mode: $V_{CCA}=V_{CCB}=Gnd$)	-0.5 to +4.6	V
V_{IB}	DC Input Voltage (Power Down Mode: $V_{CCA}=V_{CCB}=Gnd$)	-0.5 to +4.6	V
V_{OA}	DC Output Voltage	-0.5 to $V_{CCA} + 0.5$	V
V_{IB}	DC Input Voltage	-0.5 to +4.6	V
I_{IK}	DC Input Diode Current	- 20	mA
I_{OK}	DC Output Diode Current	- 50	mA
I_{OA}	DC Output Current	± 50	mA
I_{CCA}	DC V_{CCA} or Ground Current	± 100	mA
I_{CCB}	DC V_{CCB} or Ground Current	± 100	mA
P_d	Power Dissipation	400	mW
T_{stg}	Storage Temperature	-65 to +150	$^{\circ}C$
T_L	Lead Temperature (10 sec)	260	$^{\circ}C$

Absolute Maximum Ratings are those value beyond which damage to the device may occur. Functional operation under these conditions is not implied

Table 5: Recommended Operating Conditions

Symbol	Parameter	Value	Unit	
V_{CCA}	Supply Voltage	1.4 to 3.6	V	
V_{CCB}	Supply Voltage	1.4 to 3.6	V	
V_{IB}	Input Voltage (Bn)	0 to V_{CCB}	V	
V_{OA}	Output Voltage (An)	0 to V_{CCA}	V	
T_{op}	Operating Temperature	-40 to 85	$^{\circ}C$	
dt/dv	Input Rise and Fall Time (note 1)	$V_{CCB} = 3.0$ to $3.6V$	0 to 10	ns/V
		$V_{CCB} = 2.3$ to $2.7V$	0 to 20	ns/V
		$V_{CCB} = 1.4$ to $1.95V$	0 to 100	ns/V

1) V_I from 0.8V to 2.0V at $V_{CC} = 3.0V$

Table 6: DC Specification

Symbol	Parameter	Test Condition			Value					Unit
		V _{CCB} (V)(*)	V _{CCA} (V)(*)		T _A = 25 °C			-40 to 85 °C		
					Min.	Typ.	Max.	Min.	Max.	
V _{IHB}	High Level Input Voltage (Bn)	1.4	1.4 to 3.6V		0.65V _{CCB}			0.65V _{CCB}		V
		1.8			0.65V _{CCB}			0.65V _{CCB}		
		2.5			1.6			1.6		
		3.3			2.0			2.0		
V _{ILB}	Low Level Input Voltage (Bn)	1.4	1.4 to 3.6V				0.35V _{CCB}		0.35V _{CCB}	V
		1.8					0.35V _{CCB}		0.35V _{CCB}	
		2.5					0.7		0.7	
		3.3					0.8		0.8	
V _{OHA}	High Level Output Voltage	1.4 to 3.6V	1.4	I _O =-100μA	1.2			1.2		V
			2.75	I _O =-10mA	2.2			2.2		
			2.3	I _O =-8mA	2.0			2.0		
			1.65	I _O =-6mA	1.4			1.4		
			1.4	I _O =-2mA	1.1			1.1		
V _{OLA}	Low Level Output Voltage	1.4 to 3.6V	1.4	I _O =100μA			0.2		0.2	V
			2.75	I _O =10mA			0.55		0.55	
			2.3	I _O =8mA			0.30		0.30	
			1.65	I _O =6mA			0.25		0.25	
			1.4	I _O =2mA			0.20		0.20	
I _{IB}	Input Leakage Current	2.7	3.6	V _{IB} =V _{CCB} or GND			± 0.5		± 5	μA
		1.4	2.7	V _{IB} =3.6V or GND			± 0.5		± 5	μA
I _{OFF}	Power Off Leakage Current	0	0	V _{IB} =GND to 3.6V V _{OA} =GND to 3.6V			± 1.0		± 10	μA
I _{CCIB}	Quiescent Supply Current	1.4 to 3.6V	1.4 to 3.6V	V _{IB} =V _{CCB} or GND			0.5		5	μA
I _{CCIA}	Quiescent Supply Current	1.4 to 3.6V	1.4 to 3.6V	V _{IB} =V _{CCB} or GND			0.5		5	μA
ΔI _{CCIB}	Maximum Quiescent Supply Current / Input (Bn)	2.7	3.6	V _{IB} =V _{CCB} - 0.6V V _{IB} =V _{CCB} or GND					0.75	mA
		1.95	3.6							
		1.95	2.7							

(*) V_{CC} range = 3.3±0.3; 2.5±0.2V; 1.8±0.15V

Table 7: Dynamic Switching Characteristics

Symbol	Parameter	Test Condition			Value					Unit
		V _{CCB} (V)	V _{CCA} (V)		T _A = 25 °C			-40 to 85 °C		
					Min.	Typ.	Max.	Min.	Max.	
V _{OLPA}	Dynamic Low Level Quiet An Output	1.4	1.8	C _L = 30pF V _{IL} = 0V V _{IH} = V _{CC}		0.2				V
		1.4-1.8	2.5			0.25				
		1.8-2.5	3.3			0.35				
V _{OLVA}	Dynamic Low Level Quiet An Output	1.4	1.8	C _L = 30pF V _{IL} = 0V V _{IH} = V _{CC}		-0.2				V
		1.4-1.8	2.5			-0.25				
		1.8-2.5	3.3			-0.35				
V _{OHVA}	Dynamic High Level Quiet An Output	1.4	1.8	C _L = 30pF V _{IL} = 0V V _{IH} = V _{CC}		1.6				V
		1.4-1.8	2.5			2.1				
		1.8-2.5	3.3			2.7				

Table 8: AC Electrical Characteristics

Symbol	Parameter	Test Condition			Value		Unit
		V _{CCB} (V)	V _{CCA} (V)		-40 to 85 °C		
					Min.	Max.	
t _{PLH} t _{PHL}	Propagation Delay Time Bn to An	2.3 to 3.6	1.4	C _L = 10 pF	2.0	5.5	ns
		1.4 to 1.95	1.4		2.0	5.5	
		2.3 to 3.6	1.65 to 1.95		2.0	5.0	
		1.4 to 1.95	1.65 to 1.95		2.0	5.2	
		1.4 to 1.95	2.3 to 2.7		2.0	4.6	
		1.4 to 1.95	3.0 to 3.6		2.0	4.3	
		2.3 to 2.7	3.0 to 3.6		1.0	3.5	
t _{PLH} t _{PHL}	Propagation Delay Time Bn to An	2.3 to 3.6	1.4	C _L = 30 pF R _L = 500 Ω	2.0	7.5	ns
		1.4 to 1.95	1.4		2.0	7.9	
		2.3 to 3.6	1.65 to 1.95		2.0	6.0	
		1.4 to 1.95	1.65 to 1.95		2.0	6.5	
		1.4 to 1.95	2.3 to 2.7		2.0	5.7	
		1.4 to 1.95	3.0 to 3.6		2.0	5.2	
t _{OSLH} t _{OSHL}	Output To Output Skew Time (note1, 2)	1.8 ± 0.15	2.5 ± 0.2	C _L = 30 pF R _L = 500 Ω		0.5	ns
		1.8 ± 0.15	3.3 ± 0.3			0.5	
		2.5 ± 0.2	3.3 ± 0.3			0.75	

1) Skew is defined as the absolute value of the difference between the actual propagation delay for any two outputs of the same device switching in the same direction, either HIGH or LOW (t_{OSLH} = |t_{PLHm} - t_{PLHn}|; t_{OSHL} = |t_{PHLm} - t_{PHLn}|)

2) Parameter guaranteed by design

Table 9: Capacitance Characteristics

Symbol	Parameter	Test Condition			Value					Unit
		V _{CCB} (V)	V _{CCA} (V)		T _A = 25 °C			-40 to 85 °C		
					Min.	Typ.	Max.	Min.	Max.	
C _{INB}	Input Capacitance	open	open			7				pF
C _O	Output Capacitance	2.5	3.3			9				pF
C _{PD}	Power Dissipation Capacitance	2.5	3.3	f=10MHz		28				pF
		1.8	3.3			28				
		1.4	2.5			25				
		1.4	1.8			21				
		3.3	1.8			28				

1) C_{PD} is defined as the value of the IC's internal equivalent capacitance which is calculated from the operating current consumption without load. (Refer to Test Circuit). Average current can be obtained by the following equation. I_{CC(opr)} = C_{PD} × V_{CC} × f_{IN} + I_{CC}/4 (per circuit)

Figure 4: Test Circuit

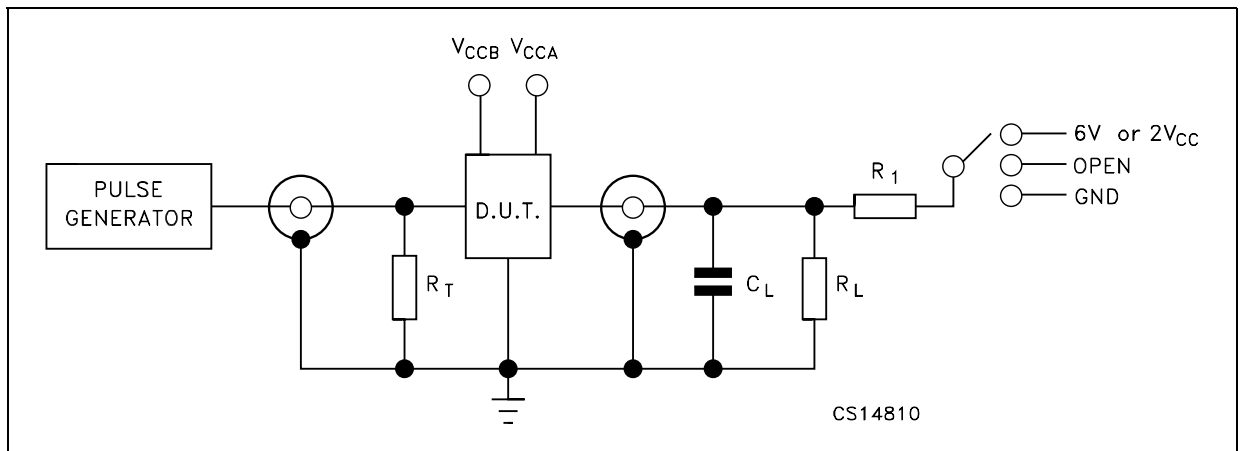

TEST	SWITCH
t _{PLH} , t _{PHL}	Open

C_L = 30pF or equivalent (includes jig and probe capacitance)
 R_L = R₁ = 500Ω or equivalent
 R_T = Z_{OUT} of pulse generator (typically 50Ω)

Table 10: Waveform Symbol Value

Symbol	V _{CC}		
	3.0 to 3.6V	2.3 to 2.7V	1.65 to 1.95V
V _{IH}	V _{CC}	V _{CC}	V _{CC}
V _M	1.5V	V _{CC} /2	V _{CC} /2
V _X	V _{OL} +0.3V	V _{OL} +0.15V	V _{OL} +0.15V
V _Y	V _{OL} -0.3V	V _{OL} -0.15V	V _{OL} -0.15V

Figure 5: Waveform - Propagation Delay ($f=1\text{MHz}$; 50% duty cycle)

Figure 6: Marking



NOTE: E = Eco Level; Y = Assy Year; WW = Assy Week; X = Marking Area; Marking Code 9521

Flip-Chip11 MECHANICAL DATA

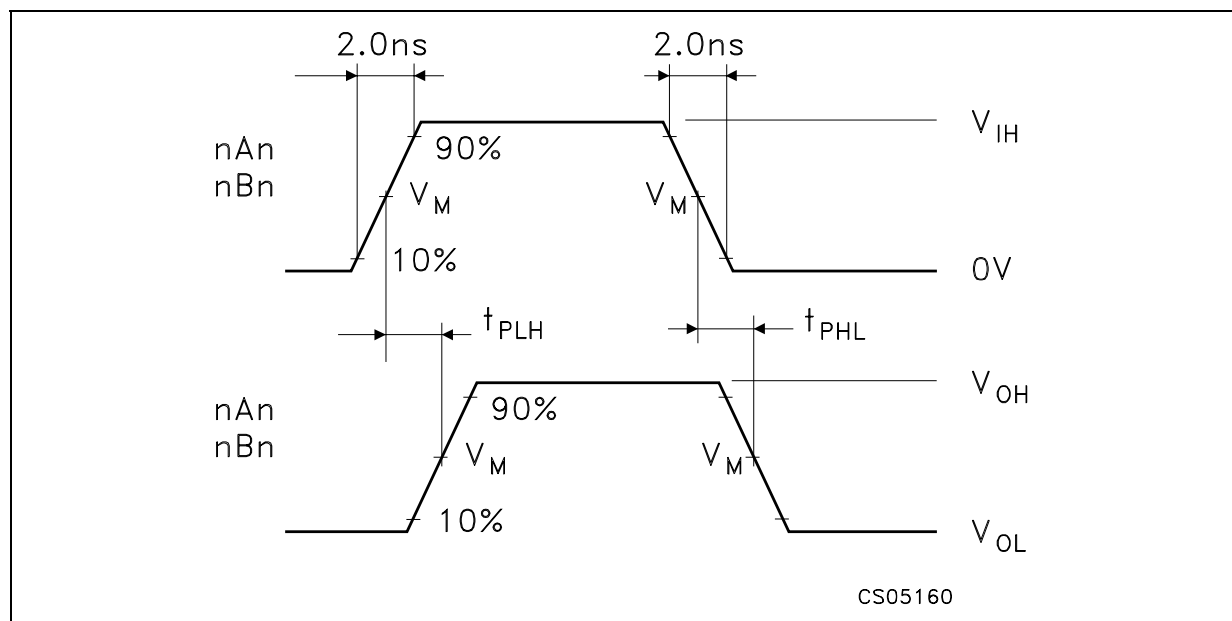
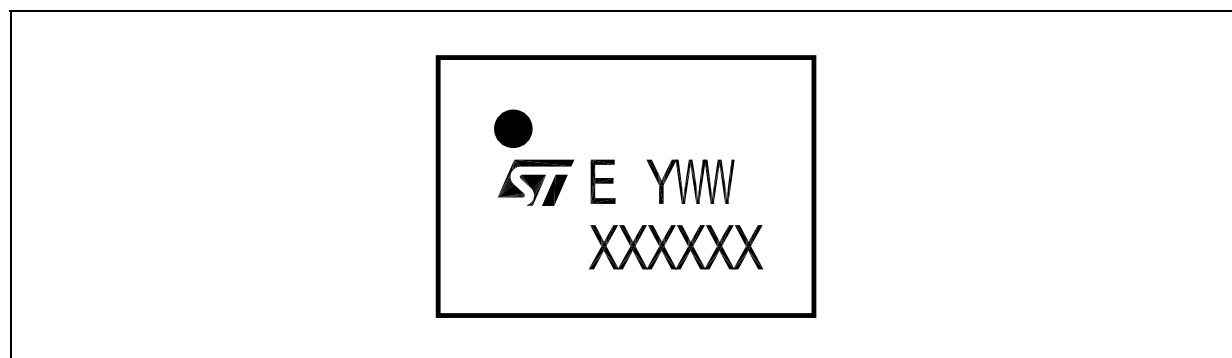
DIM.	mm.			mils		
	MIN.	TYP	MAX.	MIN.	TYP.	MAX.
A	0.585	0.65	0.715	23.0	25.6	28.1
A1	0.21	0.25	0.29	8.3	9.8	11.4
A2		0.40			15.7	
b	0.265	0.315	0.365	10.4	12.4	14.4
D	1.99	2.04	2.09	78.3	80.3	82.3
D1		1.5			59.1	
E	1.36	1.41	1.46	53.5	55.5	57.5
E1		0.866			34.1	
eD	0.2	0.25	0.30	7.9	9.8	11.8
eE	0.383	0.433	0.483	15.1	17.0	19.0
fD		0.270			10.6	
fE		0.272			10.7	
ccc		0.080			3.1	

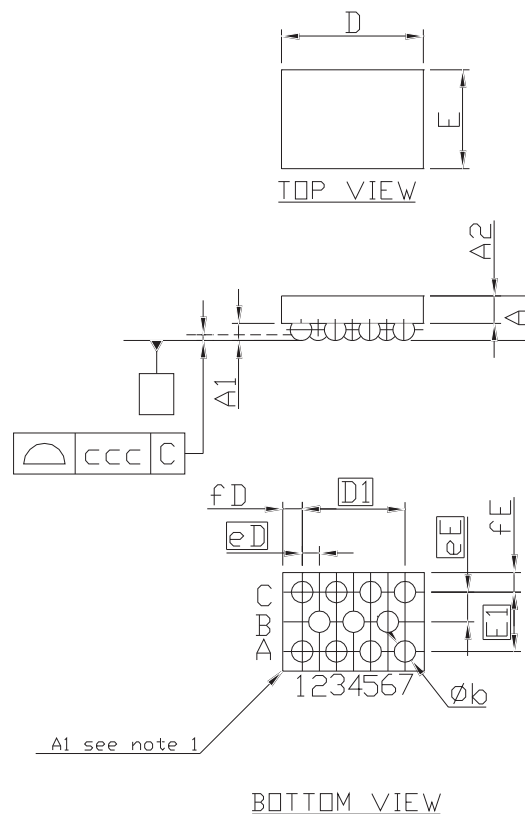

7224724E

Tape & Reel Flip-Chip 11 MECHANICAL DATA

DIM.	mm.			inch		
	MIN.	TYP	MAX.	MIN.	TYP.	MAX.
A			178			6.926
C	12.8		13.2	0.504		0.519
D	20.2			0.795		
N	49	50	51	1.929	1.969	2.008
T			12.4			0.488
Ao	2.29	2.34	2.39	0.090	0.092	0.094
Bo	1.65	1.70	1.75	0.065	0.067	0.069
Ko	0.76	0.81	0.86	0.030	0.032	0.034
Po	3.9	4	4.1	0.153	0.157	0.161
P	3.9	4	4.1	0.153	0.157	0.161

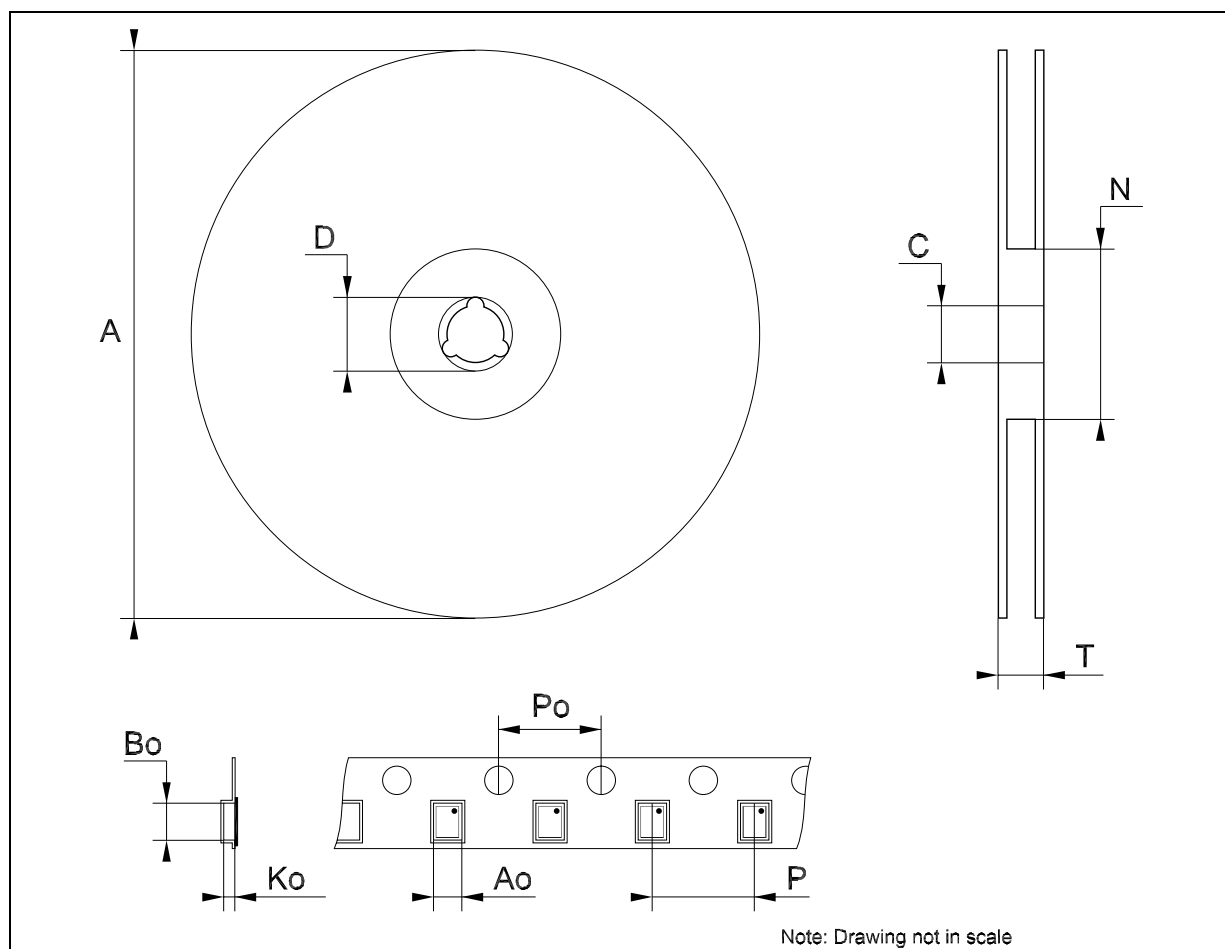

Table 11: Revision History

Date	Revision	Description of Changes
14-Oct-2004	1	First Release.
26-Oct-2004	2	Mechanical Data has been updated.
18-Nov-2004	3	Mistake V_{OHA} on table 6.
11-Feb-2005	4	Add Tape & Reel and Figure 6.
18-Feb-2005	5	Table 1 has been updated from 4000 to 5000 parts per Reel.
18-Mar-2005	6	Add Features ==> Max Data Rates.
09-May-2005	7	Table 8 and Table 9 have been updated.

Information furnished is believed to be accurate and reliable. However, STMicroelectronics assumes no responsibility for the consequences of use of such information nor for any infringement of patents or other rights of third parties which may result from its use. No license is granted by implication or otherwise under any patent or patent rights of STMicroelectronics. Specifications mentioned in this publication are subject to change without notice. This publication supersedes and replaces all information previously supplied. STMicroelectronics products are not authorized for use as critical components in life support devices or systems without express written approval of STMicroelectronics.

The ST logo is a registered trademark of STMicroelectronics

All other names are the property of their respective owners

© 2005 STMicroelectronics - All Rights Reserved

STMicroelectronics group of companies

Australia - Belgium - Brazil - Canada - China - Czech Republic - Finland - France - Germany - Hong Kong - India - Israel - Italy - Japan - Malaysia - Malta - Morocco - Singapore - Spain - Sweden - Switzerland - United Kingdom - United States of America

www.st.com