



STDD15 series

LOW CAPACITANCE DETECTION DIODE

MAIN PRODUCT CHARACTERISTICS

$I_{F(AV)}$	10 mA
V_{RRM}	15 V
$T_j(\text{max})$	150 °C
$V_F(\text{max})$	0.51 V

FEATURES AND BENEFITS

- Low diode capacitance
- Device designed for RF application
- Low profile package
- Available in 3 configurations
- Very low parasitic inductor & resistor

DESCRIPTION

The STDD15 is a dual diode series for the detection of a RF signal and the compensation of the voltage drift with the temperature. The SOT323 package makes the device ideal in application where the space saving is critical like mobile phones.

The low junction capacitance will reduce the disturbance on the RF signal

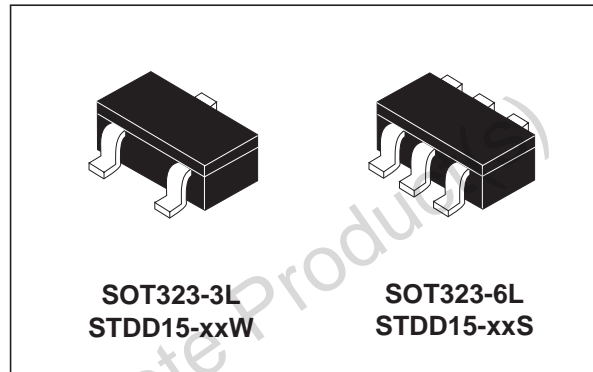

SCHEMATIC DIAGRAM

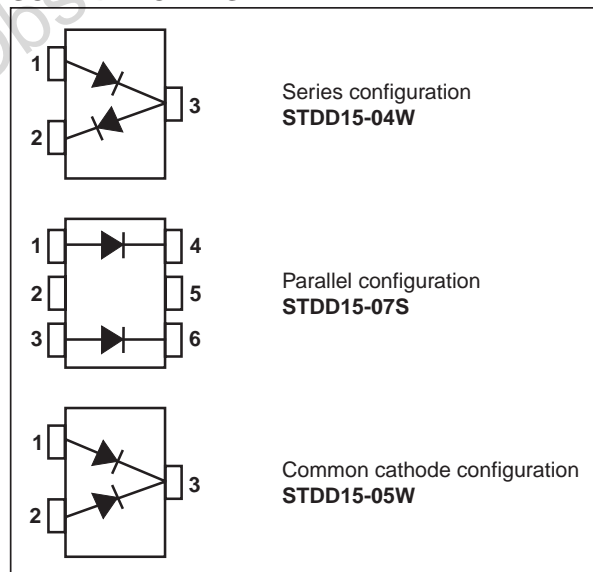

ABSOLUTE RATINGS (limiting values)

Symbol	Parameter	Value	Unit
V_{RRM}	Repetitive peak reverse voltage	15	V
I_F	Continuous forward current	10	mA
I_{FSM}	Surge non repetitive forward current	2	A
	$t_p = 10\text{ms}$		
T_{stg}	Storage temperature range	- 65 + 150	°C
T_j	Maximum operating junction temperature	150	°C

STDD15 series

THERMAL PARAMETERS

Symbol	Parameter	Value	Unit
$R_{th(j-a)}^*$	Junction to ambient	500	°C/W

*: Mounted with minimum recommended pad size, PC board FR4.

STATIC ELECTRICAL CHARACTERISTICS

Symbol	Parameter	Tests conditions		Min.	Typ.	Max.	Unit
I_R^*	Reverse leakage current	$T_j = 25^\circ\text{C}$	$V_R = 1\text{V}$			0.035	μA
		$T_j = 125^\circ\text{C}$			6	30	
		$T_j = 25^\circ\text{C}$	$V_R = 15\text{V}$			0.23	μA
		$T_j = 125^\circ\text{C}$			10	100	
V_F^*	Forward voltage drop	$T_j = 25^\circ\text{C}$	$I_F = 1\text{mA}$		350	380	mV
		$T_j = 125^\circ\text{C}$			230	260	
		$T_j = 25^\circ\text{C}$	$I_F = 10\text{mA}$		500	570	
		$T_j = 125^\circ\text{C}$			450	510	

* Pulse test: $t_p \leq 250\mu\text{s}$, $\Delta \leq 2\%$

ELECTRICAL CHARACTERISTICS

Symbol	Parameter	Tests conditions		Min.	Typ.	Max.	Unit
C	Diode capacitance	$V_R = 0\text{V}$	$F = 1\text{MHz}$			1.0	pF
R_F	Forward resistance	$I_F = 5\text{mA}$	$F = 100\text{MHz}$		15		Ω
Ls	Series inductance				1.5		nH

Fig. 1: Forward voltage drop versus forward current (typical values).

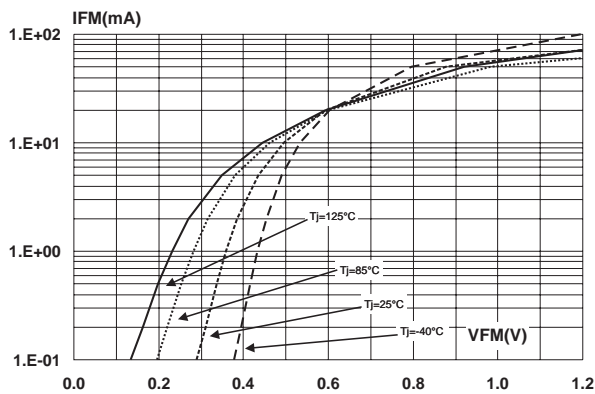

Fig. 2: Reverse leakage current versus reverse voltage applied (typical values).

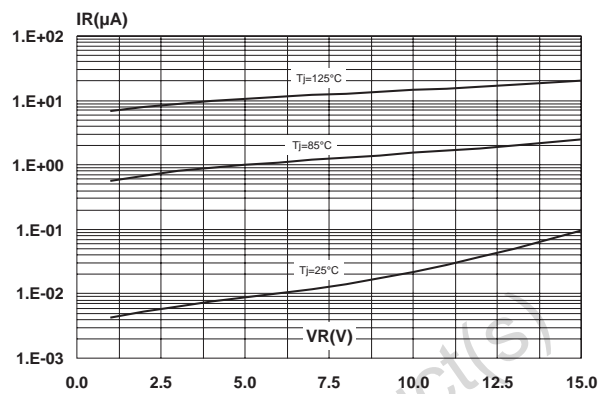

Fig. 3: Differential forward resistance versus forward current (typical values).

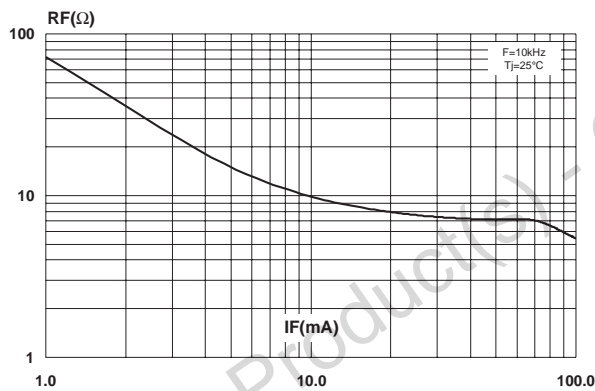

Fig. 4: Junction capacitance versus reverse voltage applied (typical values).

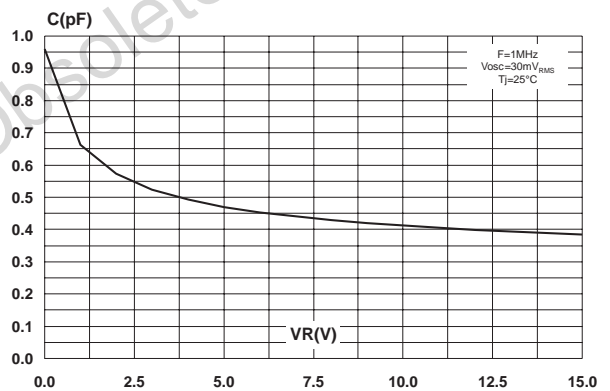

Fig. 5: Variation of thermal impedance junction to ambient versus pulse duration (printed circuit board, epoxy FR4).

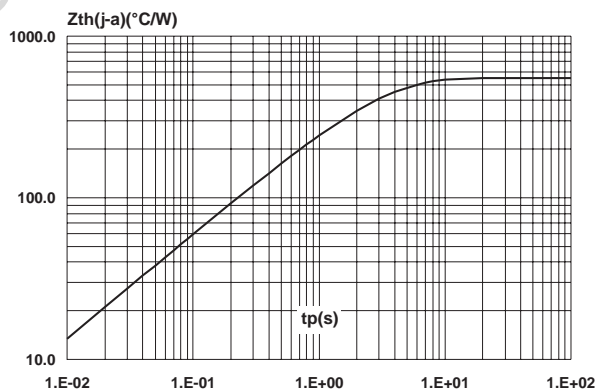
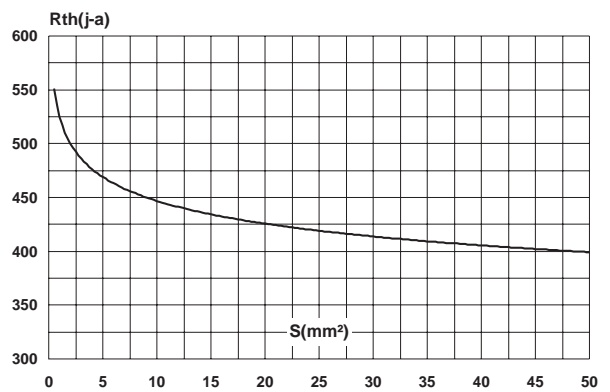

Fig. 6: Thermal resistance junction to ambient versus copper surface under each lead (printed circuit board, epoxy FR4).



STDD15 series

Electrical Model (PSPICE)

Parameter	Value	Unit
Is	2.66 e-8	A
N	1.04	
M	0.772	
Vj	0.65	V
Eg	0.69	eV
Xti	2	
Rs	15	W
Cjo	0.85 e-12	F
Bv	20	V
Ibv	10 e-3	A

PACKAGE MECHANICAL DATA SOT323-3L

REF.	DIMENSIONS					
	Millimeters			Inches		
	Min.	Typ.	Max.	Min.	Typ.	Max.
A	0.8		1.1	0.031		0.043
A1	0.0		0.1	0.0		0.004
b	0.25		0.4	0.010		0.016
c	0.1		0.26	0.004		0.010
D	1.8	2.0	2.2	0.071	0.079	0.086
E	1.15	1.25	1.35	0.045	0.049	0.053
e		0.65			0.026	
H	1.8	2.1	2.4	0.071	0.083	0.094
L	0.1	0.2	0.3	0.004	0.008	0.012
θ	0		30°	0		30°

FOOTPRINT (in millimeters)

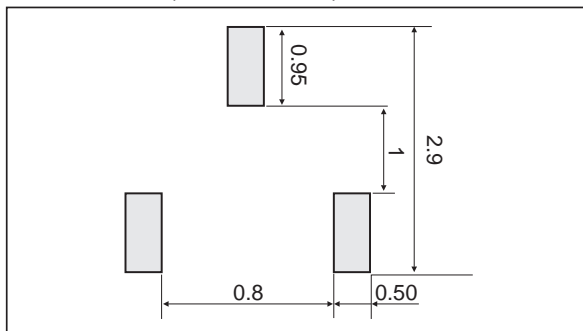

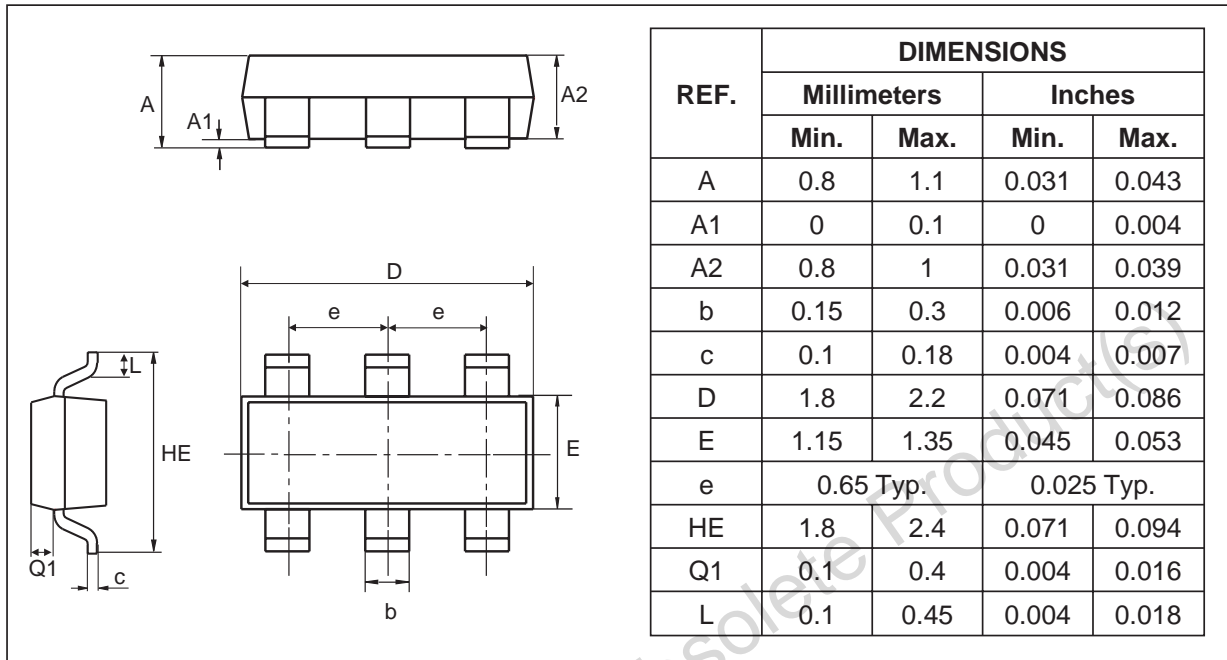
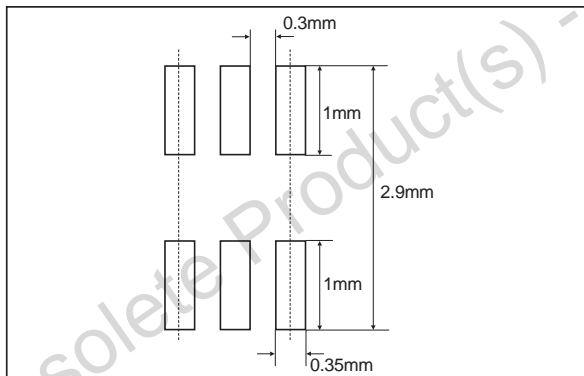
PACKAGE MECHANICAL DATA
 SOT323-6L

FOOTPRINT (in millimeters)

Note: The device fulfills the MSL level 1 after leadfree soldering profile.

Ordering code	Marking	Package	Weight	Base qty	Delivery mode
STDD15-04W	24	SOT323-3L	0.006 g	3000	Tape & reel
STDD15-05W	25	SOT323-3L	0.006 g	3000	Tape & reel
STDD15-07S	D25	SOT323-6L	0.006 g	3000	Tape & reel

Obsolete Product(s) - Obsolete Product(s)

Information furnished is believed to be accurate and reliable. However, STMicroelectronics assumes no responsibility for the consequences of use of such information nor for any infringement of patents or other rights of third parties which may result from its use. No license is granted by implication or otherwise under any patent or patent rights of STMicroelectronics. Specifications mentioned in this publication are subject to change without notice. This publication supersedes and replaces all information previously supplied. STMicroelectronics products are not authorized for use as critical components in life support devices or systems without express written approval of STMicroelectronics.

The ST logo is a registered trademark of STMicroelectronics

© 2002 STMicroelectronics - Printed in Italy - All rights reserved.

STMicroelectronics GROUP OF COMPANIES

Australia - Brazil - Canada - China - Finland - France - Germany
Hong Kong - India - Israel - Italy - Japan - Malaysia - Malta - Morocco - Singapore
Spain - Sweden - Switzerland - United Kingdom - United States.

<http://www.st.com>