



## STS4DNF60

N-channel 60V - 0.070Ω - 4A - SO-8  
STripFET™ Power MOSFET

### Features

Type	V <sub>DSS</sub>	R <sub>DS(on)</sub>	I <sub>D</sub>
STS4DNF60	60V	<0.090Ω	4A

- Standard outline for easy automated surface mount assembly
- Low threshold drive

### Description

This Power MOSFET is the latest development of STMicroelectronics unique “single feature size” strip-based process. The resulting transistor shows extremely high packing density for low on-resistance, rugged avalanche characteristics and less critical alignment steps therefore a remarkable manufacturing reproducibility.

### Application

- Switching applications

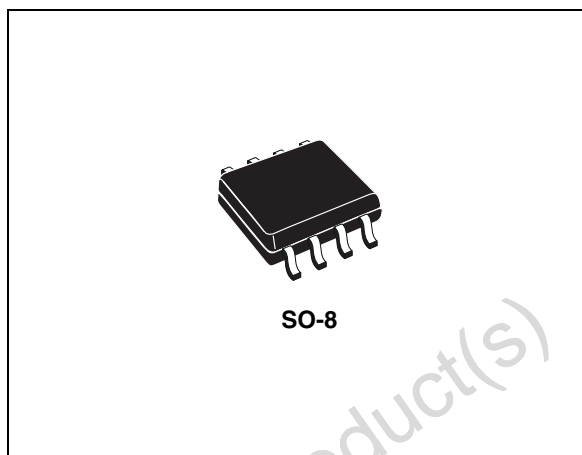

Figure 1. Internal schematic diagram

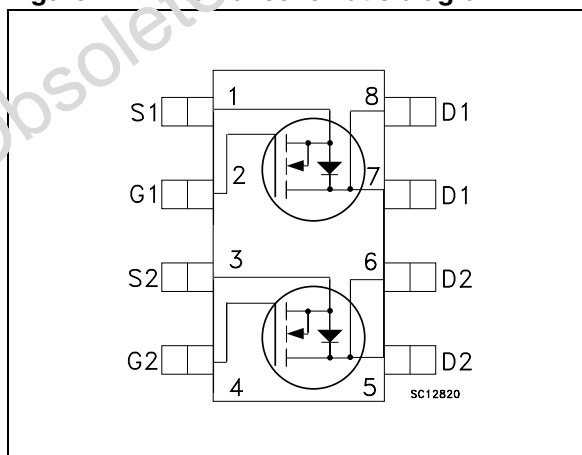

Table 1. Device summary

Order code	Marking	Package	Packaging
STS4DNF60	4DF60	SO-8	Tape & reel

# Contents

- 1      Electrical ratings ..... 3**
- 2      Electrical characteristics ..... 4**
  - 2.1    Electrical characteristics (curves) ..... 6
- 3      Test circuits ..... 8**
- 4      Package mechanical data ..... 9**
- 5      Revision history ..... 11**

Obsolete Product(s) - Obsolete Product(s)

# 1 Electrical ratings

**Table 2. Absolute maximum ratings**

Symbol	Parameter	Value	Unit
$V_{DS}$	Drain-source voltage ( $V_{GS} = 0$ )	60	V
$V_{GS}$	Gate- source voltage	$\pm 20$	V
$I_D$	Drain current (continuous) at $T_C = 25^\circ\text{C}$	4	A
$I_D$	Drain current (continuous) at $T_C = 100^\circ\text{C}$	2.5	A
$I_{DM}^{(1)}$	Drain current (pulsed)	16	A
$P_{TOT}^{(2)}$	Total dissipation at $T_C = 25^\circ\text{C}$	2	W
$T_j$ $T_{stg}$	Operating junction temperature Storage temperature	-55 to 150	$^\circ\text{C}$

1. Pulse width limited by safe operating area

2.  $P_{TOT}=1.6\text{W}$  for single operation

**Table 3. Thermal data**

Symbol	Parameter	Value	Unit
$R_{thj-pcb}$	Thermal resistance junction-pcb D.O. <sup>(1)</sup>	62.5	$^\circ\text{C/W}$

1. When mounted on inch<sup>2</sup> FR-4 board, 2 Oz Cu,  $t \leq 10\text{sec}$ , dual operation

## 2 Electrical characteristics

(T<sub>case</sub> = 25°C unless otherwise specified)

**Table 4. On /off states**

Symbol	Parameter	Test conditions	Min.	Typ.	Max.	Unit
V <sub>(BR)DSS</sub>	Drain-source breakdown voltage	I <sub>D</sub> = 250μA, V <sub>GS</sub> = 0	60			V
I <sub>DSS</sub>	Zero gate voltage drain current (V <sub>GS</sub> = 0)	V <sub>DS</sub> = Max rating V <sub>DS</sub> = Max rating, T <sub>C</sub> = 125°C			1 10	μA μA
I <sub>GSS</sub>	Gate-body leakage current (V <sub>DS</sub> = 0)	V <sub>GS</sub> = ± 20V			± 100	nA
V <sub>GS(th)</sub>	Gate threshold voltage	V <sub>DS</sub> = V <sub>GS</sub> , I <sub>D</sub> = 250μA	2		4	V
R <sub>DS(on)</sub>	Static drain-source on resistance	V <sub>GS</sub> = 10V, I <sub>D</sub> = 2A		0.070	0.090	Ω

**Table 5. Dynamic**

Symbol	Parameter	Test conditions	Min.	Typ.	Max.	Unit
g <sub>fs</sub>	Forward transconductance	V <sub>DS</sub> = 25V, I <sub>D</sub> = 2A		25		S
C <sub>iss</sub>	Input capacitance	V <sub>DS</sub> = 25 V, f = 1 MHz, V <sub>GS</sub> = 0		315		pF
C <sub>oss</sub>	Output capacitance			70		pF
C <sub>rss</sub>	Reverse transfer capacitance			30		pF
Q <sub>g</sub>	Total gate charge	V <sub>DD</sub> = 48V, I <sub>D</sub> = 4A,		10		nC
Q <sub>gs</sub>	Gate-source charge	V <sub>GS</sub> = 10V		3.5		nC
Q <sub>gd</sub>	Gate-drain charge	(see <a href="#">Figure 13</a> )		3.5		nC

**Table 6. Switching times**

Symbol	Parameter	Test conditions	Min.	Typ.	Max	Unit
$t_{d(on)}$ $t_r$	Turn-on delay time Rise time	$V_{DD} = 30V$ , $I_D = 2A$ , $R_G = 4.7\Omega$ , $V_{GS} = 10V$ (see <a href="#">Figure 12</a> )		7 18		ns ns
$t_{d(off)}$ $t_f$	Turn-off delay time Fall time	$V_{DD} = 30V$ , $I_D = 2A$ , $R_G = 4.7\Omega$ , $V_{GS} = 10V$ (see <a href="#">Figure 12</a> )		17 6		ns ns

**Table 7. Source drain diode**

Symbol	Parameter	Test conditions	Min.	Typ.	Max.	Unit
$I_{SD}$	Source-drain current				4	A
$I_{SDM}^{(1)}$	Source-drain current (pulsed)				16	A
$V_{SD}^{(2)}$	Forward on voltage	$I_{SD} = 4A$ , $V_{GS} = 0$			1.2	V
$t_{rr}$	Reverse recovery time	$I_{SD} = 4A$ , $di/dt = 100A/\mu s$		45		ns
$Q_{rr}$	Reverse recovery charge	$V_{DD} = 20V$ , $T_j = 25^\circ C$		68		nC
$I_{RRM}$	Reverse recovery current	(see <a href="#">Figure 17</a> )		3		A
$t_{rr}$	Reverse recovery time	$I_{SD} = 4A$ , $di/dt = 100A/\mu s$		50		ns
$Q_{rr}$	Reverse recovery charge	$V_{DD} = 20V$ , $T_j = 150^\circ C$		88		nC
$I_{RRM}$	Reverse recovery current	(see <a href="#">Figure 17</a> )		3.5		A

1. Pulse width limited by safe operating area

2. Pulsed: Pulse duration = 300  $\mu s$ , duty cycle 1.5%

## 2.1 Electrical characteristics (curves)

Figure 2. Safe operating area

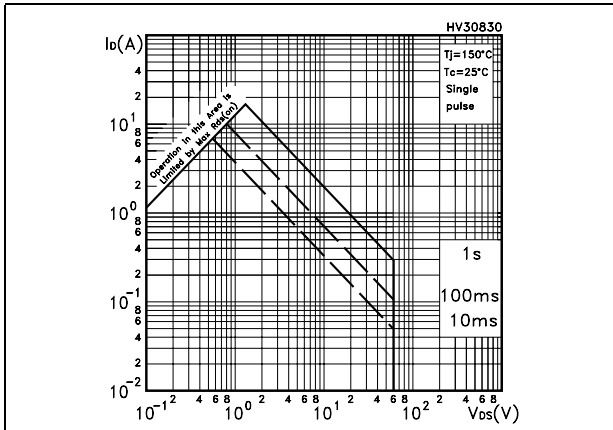

Figure 3. Thermal impedance

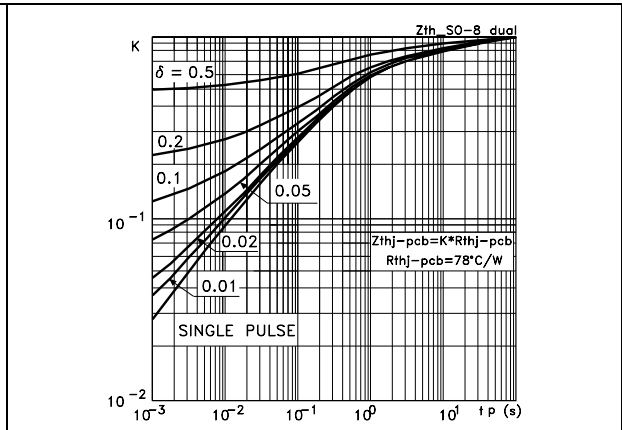

Figure 4. Output characteristics

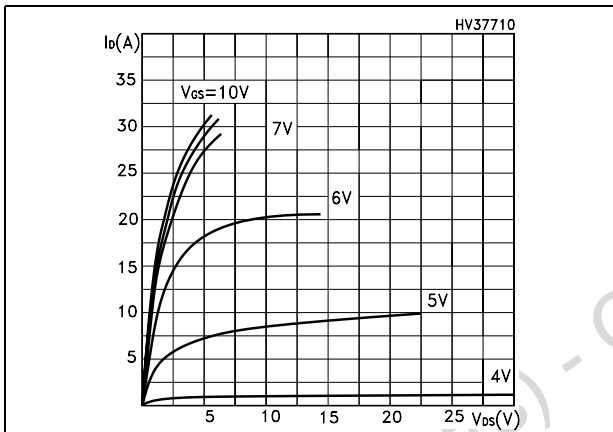

Figure 5. Transfer characteristics

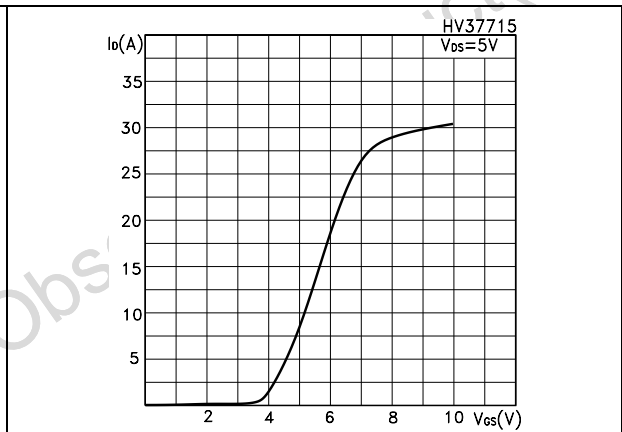

Figure 6. Source-drain diode forward characteristics

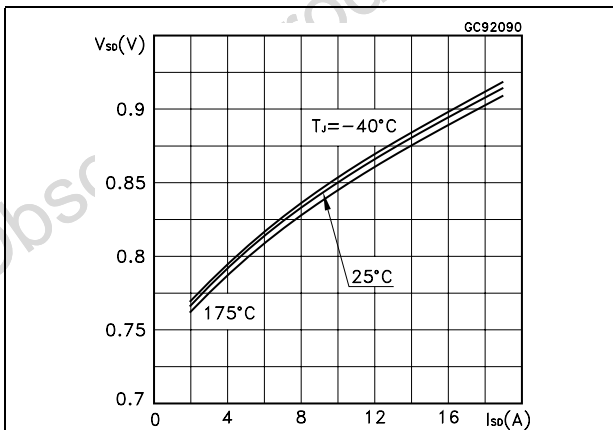

Figure 7. Static drain-source on resistance

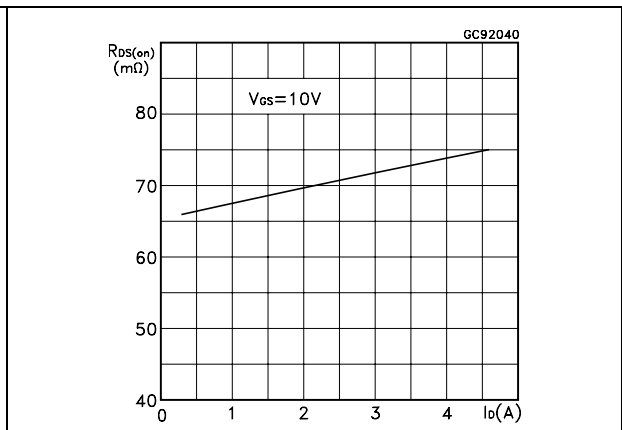

Figure 8. Gate charge vs gate-source voltage Figure 9. Capacitance variations

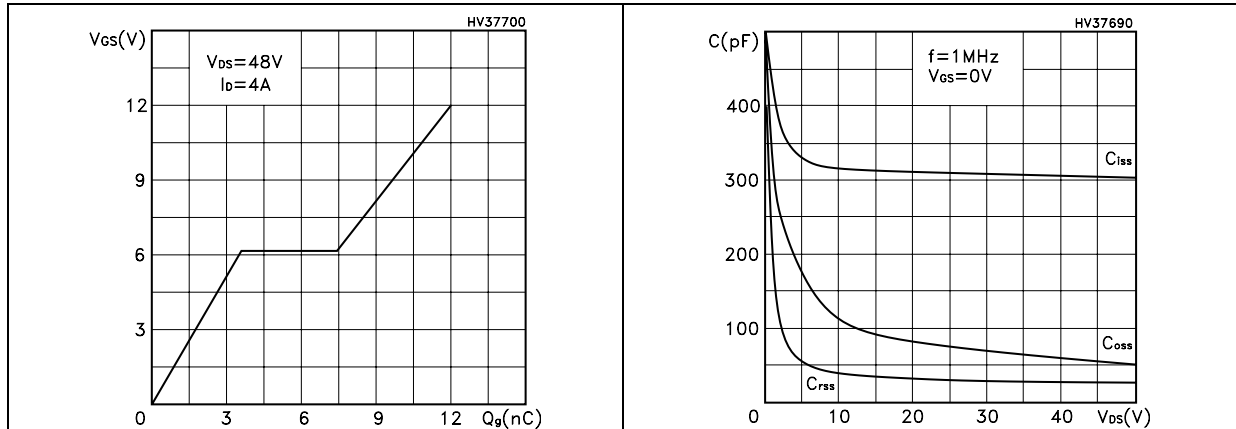
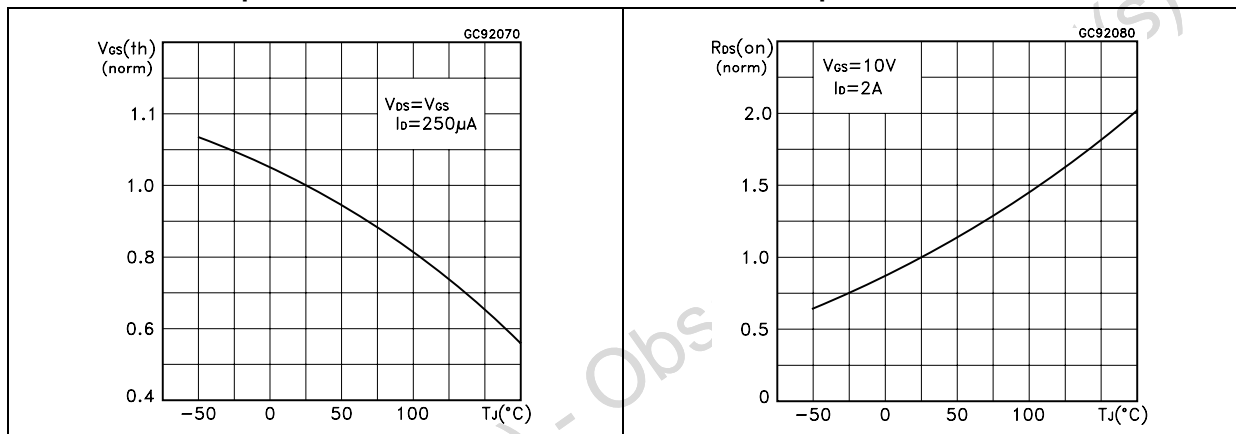

Figure 10. Normalized gate threshold voltage vs temperature Figure 11. Normalized on resistance vs temperature



Obsolete Product(s) - Obs

### 3 Test circuits

Figure 12. Switching times test circuit for resistive load

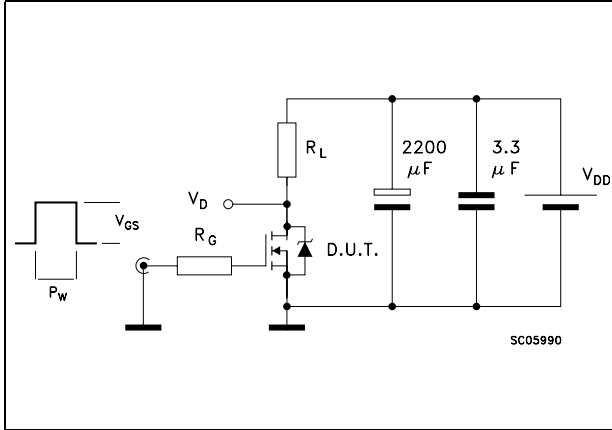

Figure 13. Gate charge test circuit

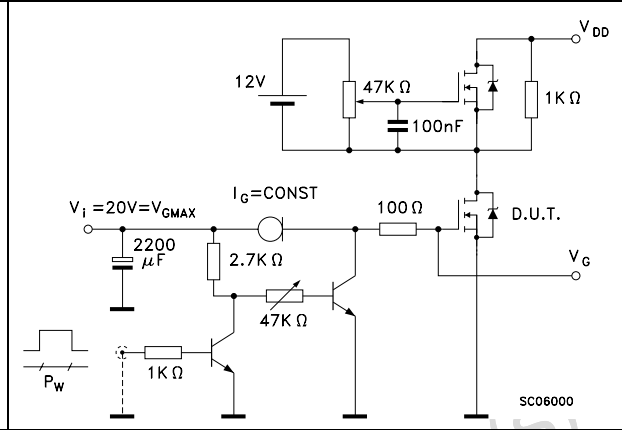

Figure 14. Test circuit for inductive load switching and diode recovery times

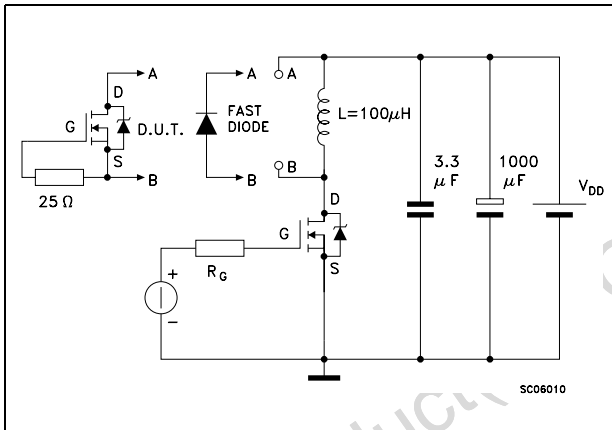

Figure 15. Unclamped Inductive load test circuit

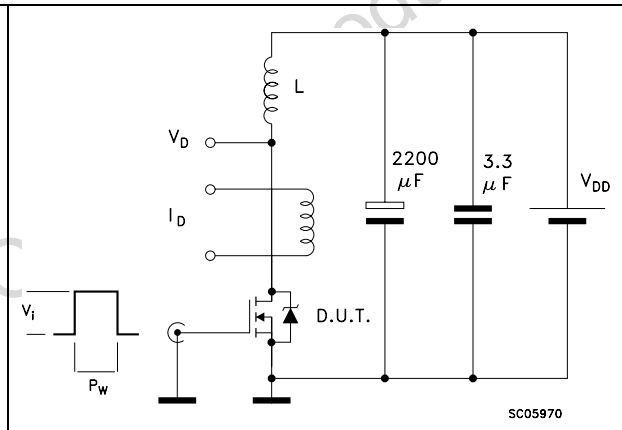

Figure 16. Unclamped inductive waveform

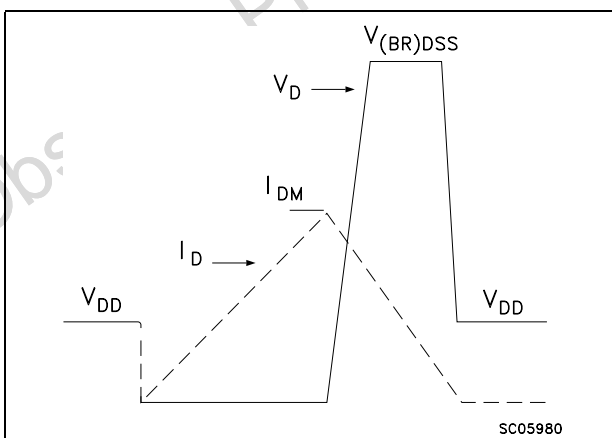
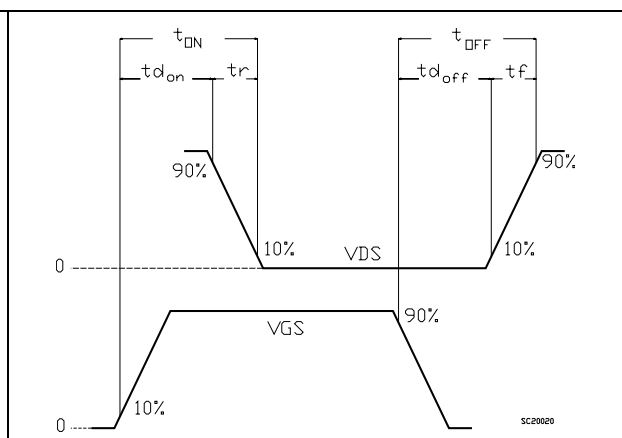

Figure 17. Switching time waveform



## 4 Package mechanical data

In order to meet environmental requirements, ST offers these devices in ECOPACK® packages. These packages have a Lead-free second level interconnect. The category of second level interconnect is marked on the package and on the inner box label, in compliance with JEDEC Standard JESD97. The maximum ratings related to soldering conditions are also marked on the inner box label. ECOPACK is an ST trademark. ECOPACK specifications are available at: [www.st.com](http://www.st.com)

Obsolete Product(s) - Obsolete Product(s)

**SO-8 MECHANICAL DATA**

DIM.	mm.			inch		
	MIN.	TYP.	MAX.	MIN.	TYP.	MAX.
A			1.75			0.068
a1	0.1		0.25	0.003		0.009
a2			1.65			0.064
a3	0.65		0.85	0.025		0.033
b	0.35		0.48	0.013		0.018
b1	0.19		0.25	0.007		0.010
C	0.25		0.5	0.010		0.019
c1	45 (typ.)					
D	4.8		5.0	0.188		0.196
E	5.8		6.2	0.228		0.244
e		1.27			0.050	
e3		3.81			0.150	
F	3.8		4.0	0.14		0.157
L	0.4		1.27	0.015		0.050
M			0.6			0.023
S	8 (max.)					

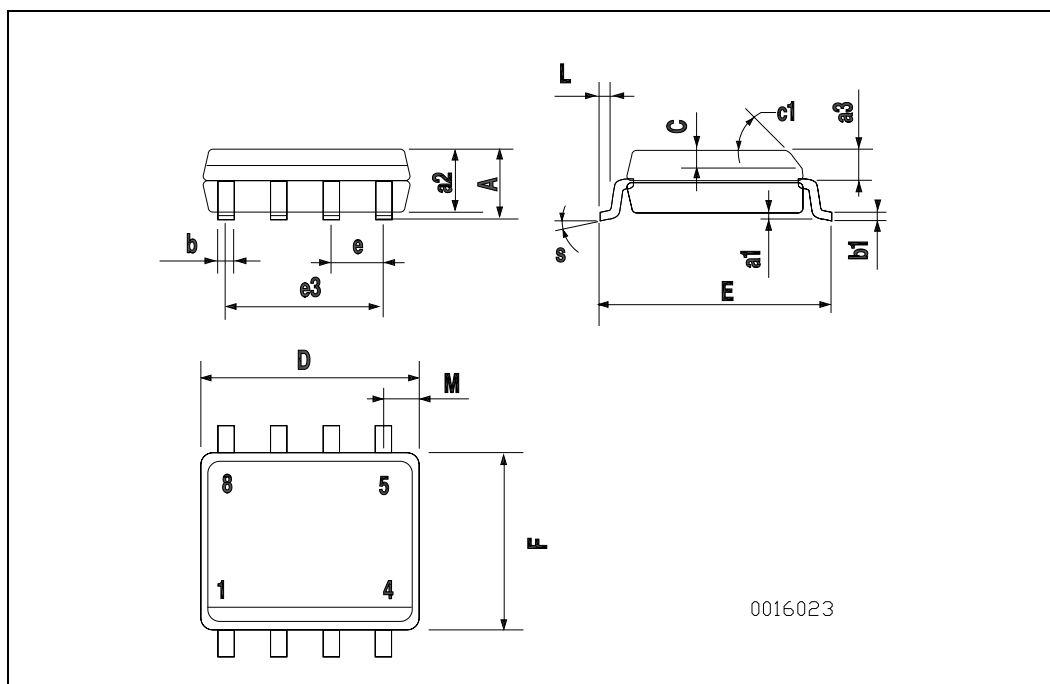

0016023

## 5 Revision history

Table 8. Revision history

Date	Revision	Changes
17-May-2007	1	First release
02-Aug-2007	2	Marking has been updated

Obsolete Product(s) - Obsolete Product(s)

**Please Read Carefully:**

Information in this document is provided solely in connection with ST products. STMicroelectronics NV and its subsidiaries ("ST") reserve the right to make changes, corrections, modifications or improvements, to this document, and the products and services described herein at any time, without notice.

All ST products are sold pursuant to ST's terms and conditions of sale.

Purchasers are solely responsible for the choice, selection and use of the ST products and services described herein, and ST assumes no liability whatsoever relating to the choice, selection or use of the ST products and services described herein.

No license, express or implied, by estoppel or otherwise, to any intellectual property rights is granted under this document. If any part of this document refers to any third party products or services it shall not be deemed a license grant by ST for the use of such third party products or services, or any intellectual property contained therein or considered as a warranty covering the use in any manner whatsoever of such third party products or services or any intellectual property contained therein.

**UNLESS OTHERWISE SET FORTH IN ST'S TERMS AND CONDITIONS OF SALE ST DISCLAIMS ANY EXPRESS OR IMPLIED WARRANTY WITH RESPECT TO THE USE AND/OR SALE OF ST PRODUCTS INCLUDING WITHOUT LIMITATION IMPLIED WARRANTIES OF MERCHANTABILITY, FITNESS FOR A PARTICULAR PURPOSE (AND THEIR EQUIVALENTS UNDER THE LAWS OF ANY JURISDICTION), OR INFRINGEMENT OF ANY PATENT, COPYRIGHT OR OTHER INTELLECTUAL PROPERTY RIGHT.**

**UNLESS EXPRESSLY APPROVED IN WRITING BY AN AUTHORIZED ST REPRESENTATIVE, ST PRODUCTS ARE NOT RECOMMENDED, AUTHORIZED OR WARRANTED FOR USE IN MILITARY, AIR CRAFT, SPACE, LIFE SAVING, OR LIFE SUSTAINING APPLICATIONS, NOR IN PRODUCTS OR SYSTEMS WHERE FAILURE OR MALFUNCTION MAY RESULT IN PERSONAL INJURY, DEATH, OR SEVERE PROPERTY OR ENVIRONMENTAL DAMAGE. ST PRODUCTS WHICH ARE NOT SPECIFIED AS "AUTOMOTIVE GRADE" MAY ONLY BE USED IN AUTOMOTIVE APPLICATIONS AT USER'S OWN RISK.**

Resale of ST products with provisions different from the statements and/or technical features set forth in this document shall immediately void any warranty granted by ST for the ST product or service described herein and shall not create or extend in any manner whatsoever, any liability of ST.

ST and the ST logo are trademarks or registered trademarks of ST in various countries.

Information in this document supersedes and replaces all information previously supplied.

The ST logo is a registered trademark of STMicroelectronics. All other names are the property of their respective owners.

© 2007 STMicroelectronics - All rights reserved

STMicroelectronics group of companies

Australia - Belgium - Brazil - Canada - China - Czech Republic - Finland - France - Germany - Hong Kong - India - Israel - Italy - Japan - Malaysia - Malta - Morocco - Singapore - Spain - Sweden - Switzerland - United Kingdom - United States of America

[www.st.com](http://www.st.com)