

LOC		DIST		P		F		ZONE		LTR		REVISIONS		DATE	APPD
CH	11											B	ECN 95030204	02/MAR/95	P. G.

1. RETROFIT CONTACT FOR METRIMATE AND AMPLIMITE POWER CONTACT.
2. WIRE BARREL WILL ACCEPT #10 AWG WIRE.
3. MATES WITH PN 193643-1.

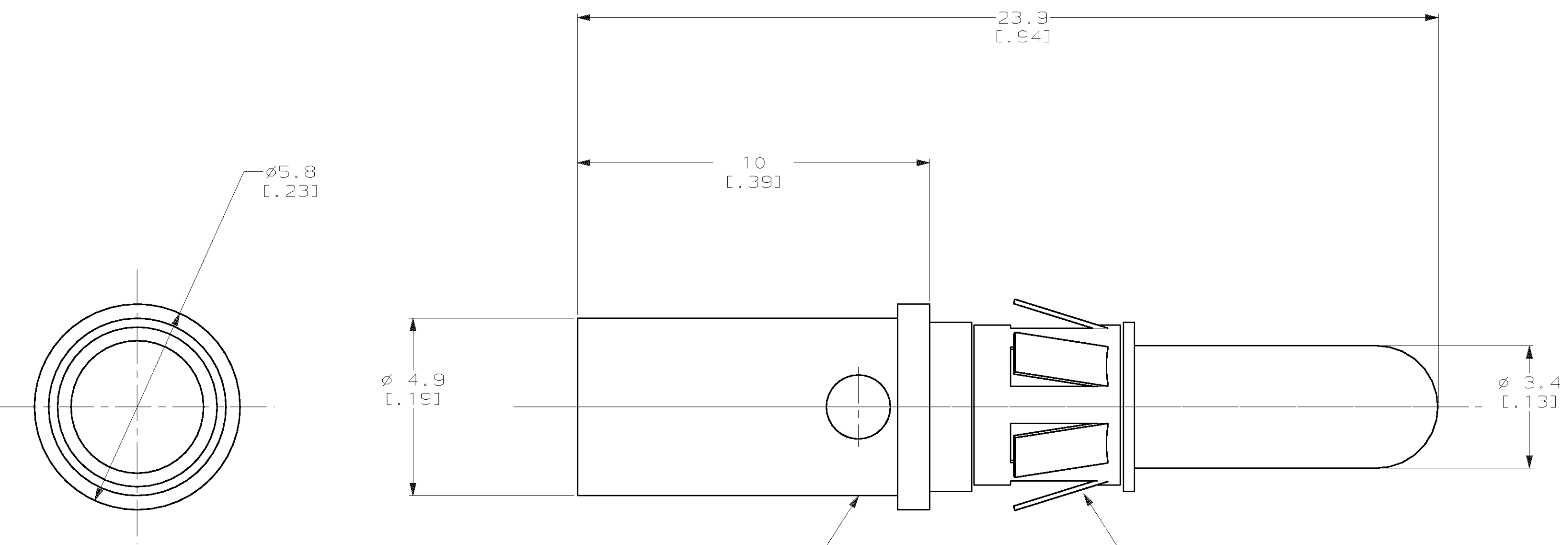

PIN BODY MATERIAL: COPPER ALLOY
 FINISH: 0.76µM [0.000030] MIN GOLD OVER
 1.27µM [0.000050] MIN NICKEL

RETENTION CLIP MATERIAL: STAINLESS STEEL

193642-1
 PART NO

DO NOT SCALE PRINT. UNLESS SPECIFIED DIMENSIONS IN mm [INCHES] TOLERANCES ON : 2 PLC DEC ±0.5 [0.02] 3 PLC DEC ±0.25 [0.010] ANGLES ± -	DR D. WILSON 08-12-92	AMP Incorporated Harrisburg, PA 17105-3608
	CHK R. JAYNE 08-17-92	
MATERIAL -	APPD A. GRIFFIN 08-17-92	NAME
FINISH -	APPD P. GLASER 08-17-92	PIN ASSY, POWER, #10 AWG
	PRODUCT SPEC -	SIZE CAGE CODE DRAWING NO C 00779 C=193642
	APPLICATION SPEC -	SCALE 10:1 SHEET 1 OF 1
	WEIGHT -	

THIS DRAWING IS A CONTROLLED DOCUMENT FOR AMP INCORPORATED. IT IS SUBJECT TO CHANGE AND THE CONTROLLING ENGINEERING ORGANIZATION SHOULD BE CONTACTED FOR THE LATEST REVISION.