

THIS DRAWING IS UNPUBLISHED. RELEASED FOR PUBLICATION DEC ,2011.  
 © COPYRIGHT 2011 By - ALL RIGHTS RESERVED.

LOC	DIST	REVISIONS					
GP	00	P	LTR	DESCRIPTION	DATE	DWN	APVD
		E		REVISED PER ECO-13-000397	31JAN2013	CJV	CWR

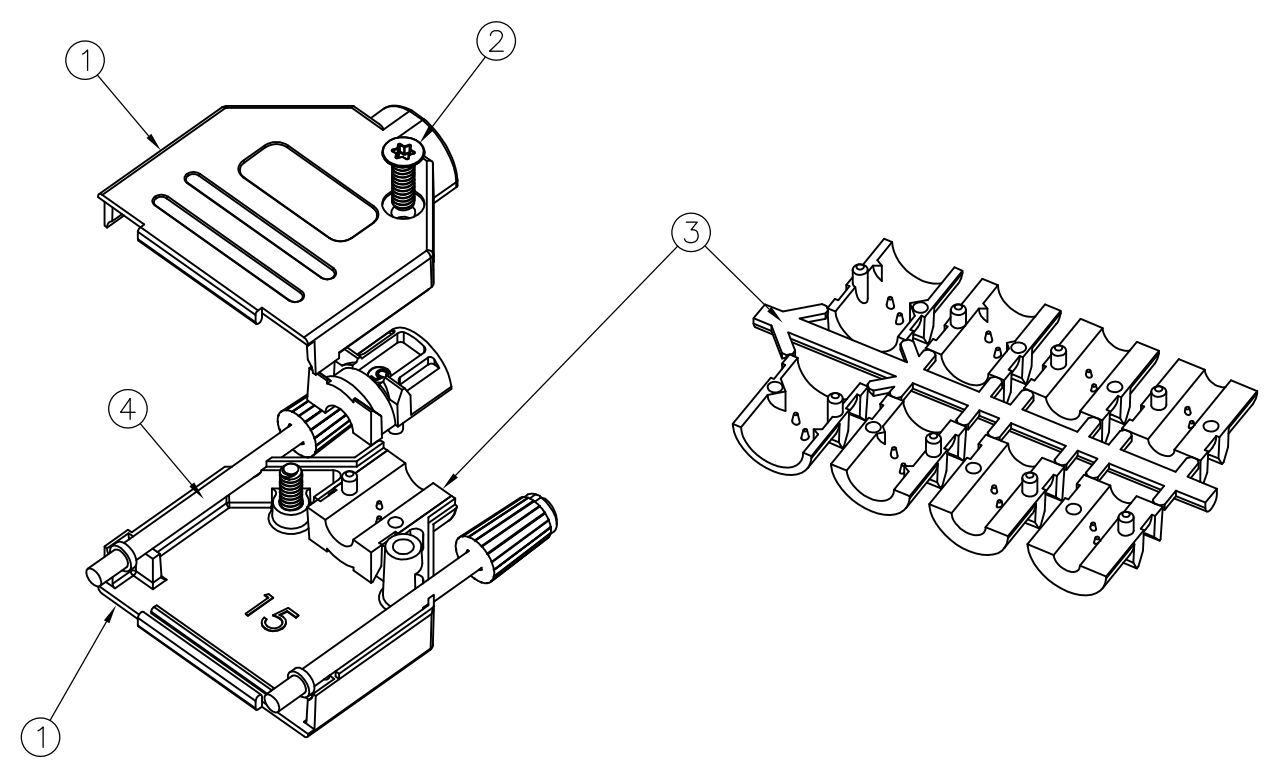
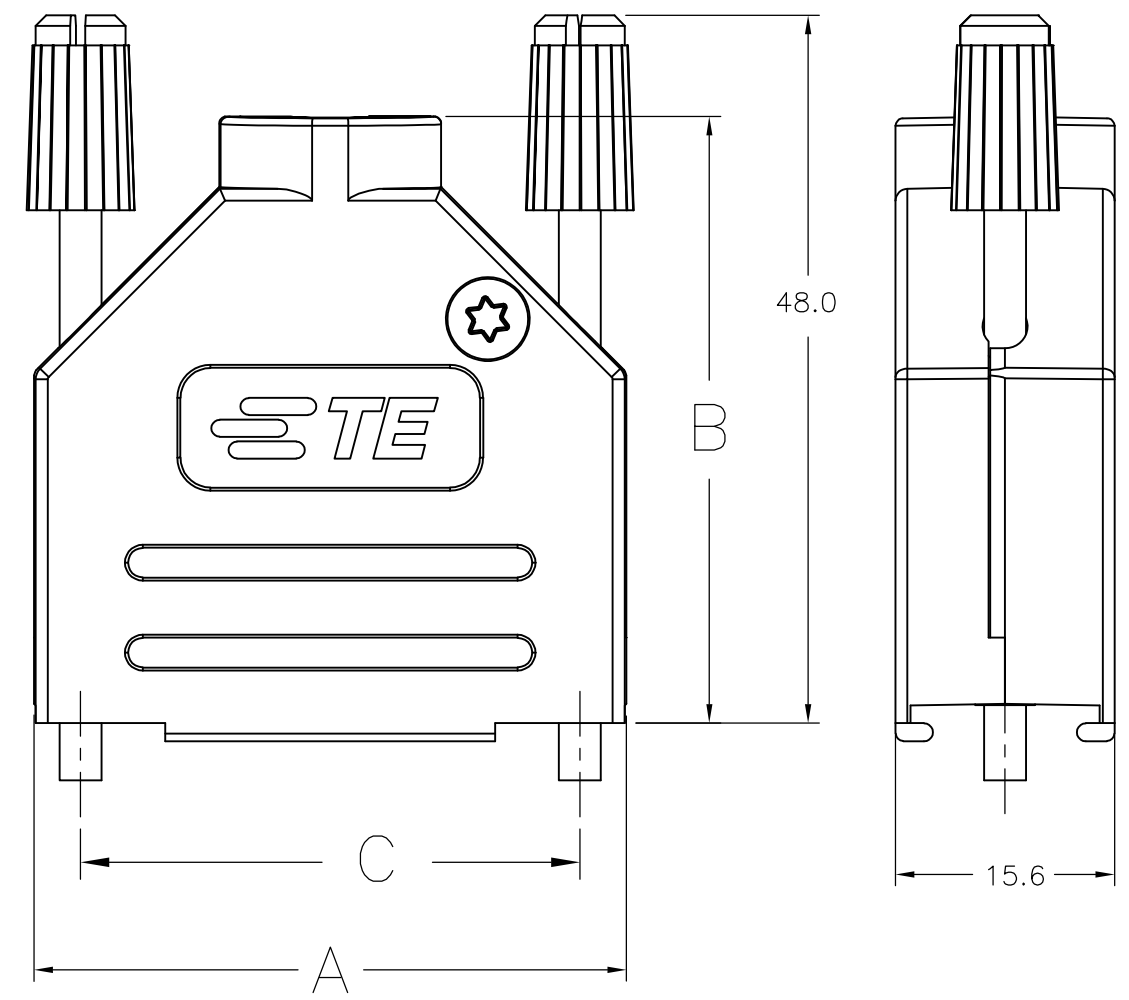

- 1. FOR ASSEMBLY DETAILS, REFER TO LEAFLET 2227518-1.
- 2. BULK PACKAGED BACKSHELL ASSEMBLIES: ITEMS 1 THRU 4, 100 TIMES QTY SHOWN IN TABLE IN 1 BAG FOR EACH ITEM. ALL BAGS IN 1 BOX WITH (1) 2227518-1 LEAFLET.
- 3. INDIVIDUALLY PACKAGED SHELL ASSEMBLIES: 1 BAG CONTAINS ALL COMPONENTS FOR 1 COMPLETE ASSEMBLY. 100 BAGS PER BOX, (1) 2227518-1 LEAFLET PER BOX.
- 4. TERMINATES 4.0-13.0 CABLE DIAMETERS.
- 5. 15 POSITION SHOWN.
- 6. TRIVALENT CHROMIUM CHROMATE COATING OVER ZINC PLATING.
- 7. OPTIONAL CABLE CRIMP KIT AVAILABLE FOR 6.0-9.5 DIAMETER CABLE. SEE 1478764.

3	63.5	52.2	69.5	TORX	4-40 UNC	4	37 WAY	5-2198617-4
3	47.0	47.8	53.0	TORX	4-40 UNC	3	25 WAY	5-2198617-3
3	33.3	40.5	39.3	TORX	4-40 UNC	2	15 WAY	5-2198617-2
3	25.0	38.3	31.0	TORX	4-40 UNC	1	9 WAY	5-2198617-1
2	63.5	52.2	69.5	TORX	4-40 UNC	4	37 WAY	3-2198617-7
2	47.0	47.8	53.0	TORX	4-40 UNC	3	25 WAY	2-2198617-5
2	33.3	40.5	39.3	TORX	4-40 UNC	2	15 WAY	1-2198617-5
2	25.0	38.3	31.0	TORX	4-40 UNC	1	9 WAY	2198617-9
PACKAGING	C	B	A	SELF TAPPING FIXING SCREW TYPE	JACKSCREW THREAD	SHELL SIZE	POSITION	PART NUMBER

4	JACKSCREW ASSEMBLY, 4-40	POLYAMIDE, UL94 V2 KNOB	BLACK	2
		CARBON STEEL SHAFT	6	
3	STRAIN RELIEF SET	POLYCARBONATE UL94 V0	BLACK	1
2	SELF TAPPING FIXING SCREW	CARBON STEEL	6	2
1	BACKSHELL HALF	ABS UL94 V0	NICKEL	2
ITEM	DESCRIPTION	MATERIAL	FINISH	QTY

THIS DRAWING IS A CONTROLLED DOCUMENT. DIMENSIONING AND TOLERANCING PER ASME Y14.5M-2009

DIMENSIONS: mm

TOLERANCES UNLESS OTHERWISE SPECIFIED:  
 0 PLC ± 0.5  
 1 PLC ± 0.5  
 2 PLC ± 0.5  
 3 PLC ± 0.5  
 4 PLC ± 0.5  
 ANGLES ± 0.5°

MATERIAL: SEE TABLE  
 FINISH: SEE TABLE

APVD: C. VALENTINE 08DEC2011  
 CHK: C. ROHDE 08DEC2011  
 APVD: C. ROHDE 08DEC2011  
 PRODUCT SPEC: -  
 APPLICATION SPEC: -  
 WEIGHT: -

STE TE Connectivity

NAME: SHIELDED PLASTIC BACKSHELL STRAIGHT ENTRY

SIZE: A3 CAGE CODE: 00779 DRAWING NO: C-2198617 RESTRICTED TO: -

CUSTOMER DRAWING SCALE: NTS SHEET: 1 OF 1 REV: E