

CODING A AS SHOWN
Kodierung A wie gezeichnet

REVISIONS					
P	LTR	DESCRIPTION	DATE	DWN	APVD
A3		REVISED PER ECO-11-005150	30MAR2011	RK	HMR
A4		FOR DETAILS SEE PCN E-12-002103	07MAY2012	CG	JG
A5		REVISED PER PCN E-19-019109	09DEC2019	MK	JG
A6		REVISED PER PCN-21-119507	02NOV2021	DRK	AW

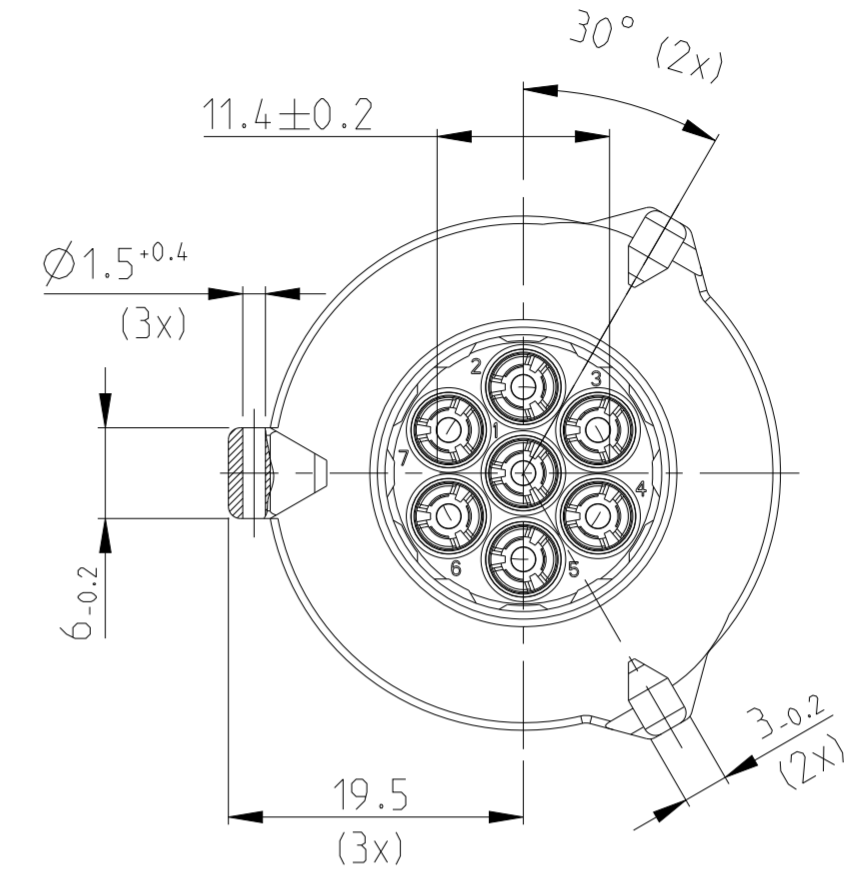
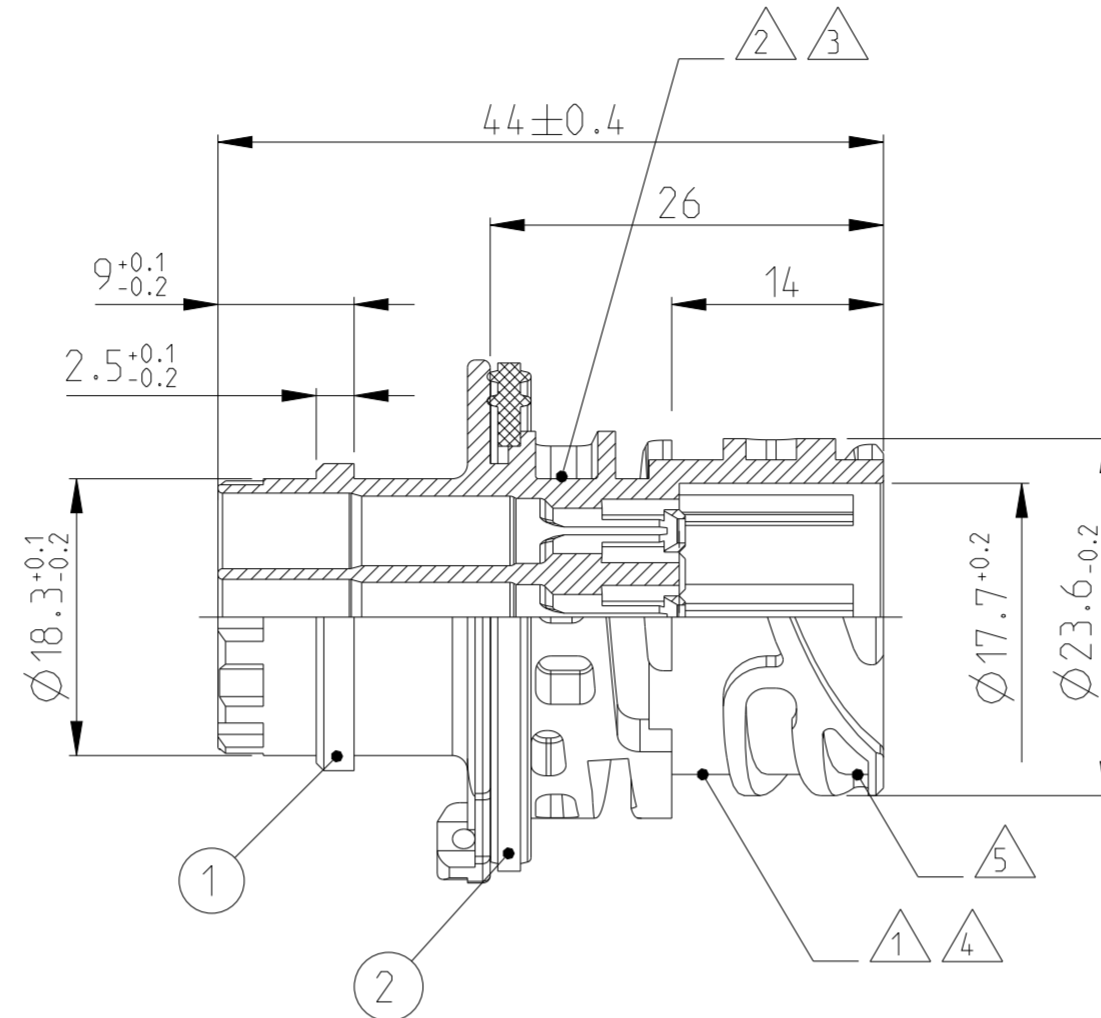
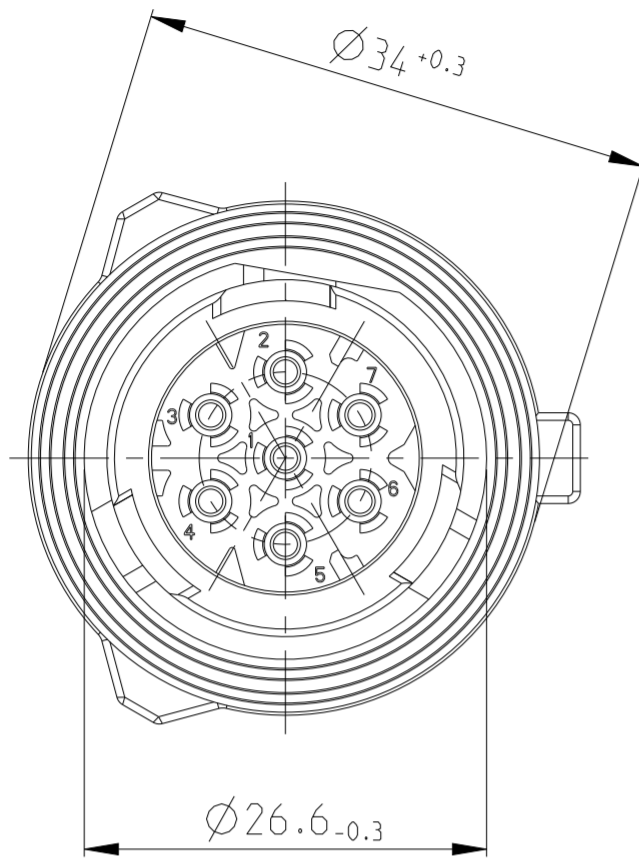

NOTES
Bemerkungen

- 1 AMP OR TE CONNECTIVITY LOGO AND TE CONNECTIVITY SINGLE PART NUMBER
AMP oder TE CONNECTIVITY Logo und TE CONNECTIVITY Einzelteilnummer
- 2 MATERIAL MARKING
Werkstoffkennzeichnung
- 3 REVISION OF THE MOULD
Werkzeugaenderungsindex
- 4 PRODUCTION DATE
Produktionsdatum
- 5 CAVITY MARKING
Nestmarkierung

- 7 PANEL MOUNTING WITH FIXING RING
TE CONNECTIVITY PART NO. 965687-1
Hinterwandmontage mit Befestigungsring
TE CONNECTIVITY-Nr. 965687-1

- 8 IN THE CASE OF THE NEW DESIGNS, THE DIMENSIONS OF THE CUT OFF SHOULD BE PLACED NEAR THE LOWER TOLERANCE LIMIT
Bei Neukonstruktionen sollten die Masse des Blechausschnitts an die untere Toleranzgrenze gelegt werden

- A6 9 FOR THE CUSTOMER'S INCOMING INSPECTION OR PRODUCTION LINE INSPECTION, THE MAXIMUM TEST PRESSURE ALLOWED FOR USE IS ACCORDING TO IPX7 WITHIN SPECIFICATION 108-18622 AND SHOULD NOT EXCEED THAT PRESSURE

USE ONLY CONTACTS WITH SINGLE WIRE SEALS!
Es sind nur Kontakte mit Einzeldichtungen einzusetzen!

TE CONNECTIVITY 1703020
MAX. WIRE THICKNESS: 2.5 mm² FLR
max. Drahtgrosse:

FURTHER CODINGS:
weitere Kodierungen:

CODING B
Kodierung B

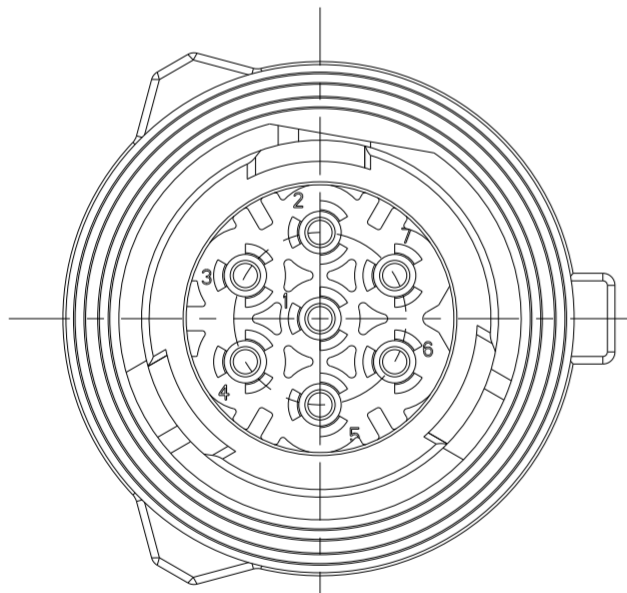

CODING C
Kodierung C

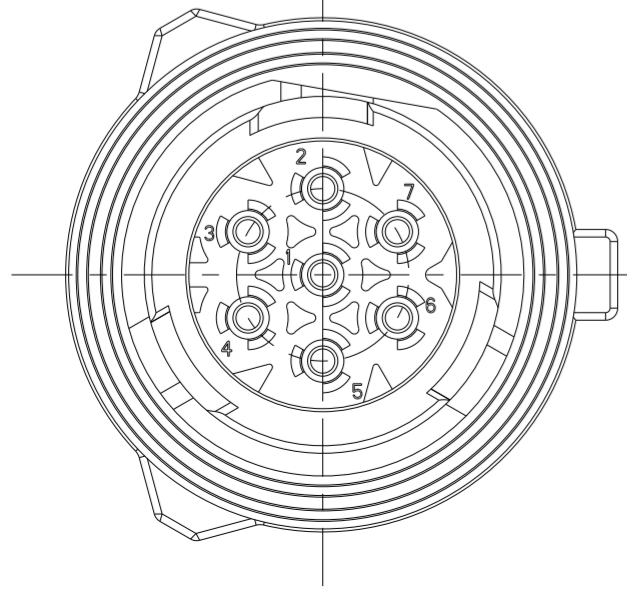

CUT OFF
(Material THICKNESS: 2.5^{+0.1} MM)

- 7 8 Befestigungsausschnitt
(Materialstaerke: 2.5^{+0.1} mm)

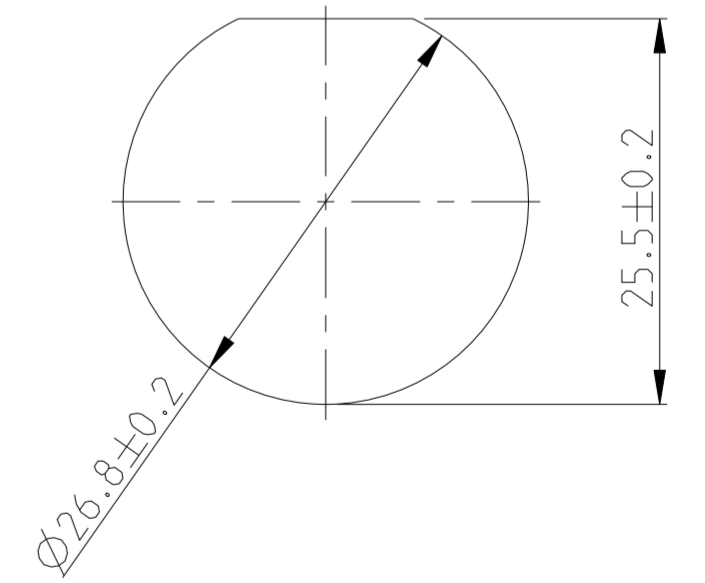

Bestell-Nr. ORDER-NO.	REV.	Bestueckbare Kategorie USED CONTACT CATEGORIES	POS.	Stueck QTY	Benennung Einzelteil DESCRIPTION SINGE PART	Werkstoff MATERIAL	Oberflaeche/Farbe SURFACE/C OLOUR
3-1718230-1	A	1-7	2	1	SEALING Dichtung	SILICONE Silikon	GREEN/gruen
			1	1	7POS. PIN HOUSING CODE C 7pol. Stiftgehaeuse Kodierung C	PBT-GF20	GREEN/gruen
2-1718230-1	A	1-7	2	1	SEALING Dichtung	SILICONE Silikon	GREEN/gruen
			1	1	7POS. PIN HOUSING CODE B 7pol. Stiftgehaeuse Kodierung B	PBT-GF20	GREY/grau
1-1718230-1	A	1-7	2	1	SEALING Dichtung	SILICONE Silikon	GREEN/gruen
			1	1	7POS. PIN HOUSING CODE A 7pol. Stiftgehaeuse Kodierung A	PBT-GF20	BLUE/blau
1718230-4	A	1-4	2	1	SEALING Dichtung	SILICONE Silikon	GREEN/gruen
			1	1	4POS. PIN HOUSING CODE A 4pol. Stiftgehaeuse Kodierung A	PBT-GF20	BLACK/schwarz
1718230-3	A	1-5	2	1	SEALING Dichtung	SILICONE Silikon	GREEN/gruen
			1	1	5POS. PIN HOUSING CODE A 5pol. Stiftgehaeuse Kodierung A	PBT-GF20	BLACK/schwarz
1718230-2	A	1-6	2	1	SEALING Dichtung	SILICONE Silikon	GREEN/gruen
			1	1	6POS. PIN HOUSING CODE A 6pol. Stiftgehaeuse Kodierung A	PBT-GF20	BLACK/schwarz
1718230-1	A	1-7	2	1	SEALING Dichtung	SILICONE Silikon	GREEN/gruen
			1	1	7POS. PIN HOUSING CODE A 7pol. Stiftgehaeuse Kodierung A	PBT-GF20	BLACK/schwarz

TOLERANCES UNLESS OTHERWISE SPECIFIED ACC. TO DIN 16901-140 CENTRIC TO NOMINAL DIMENSION. EDITION 1982-11 SHALL APPLY. Freimass toleranzen nach DIN 16901-140. Es gilt die Ausgabe 1982-11.	
DIESE ZEICHNUNG IST EIN KONTROLLIERTES DOKUMENT. BEMASSUNGEN UND TOLERANZEN GEMAESS GPS (ISO STANDARDS).	
THIS DRAWING IS A CONTROLLED DOCUMENT. DIMENSIONING AND TOLERANCING PER GPS (ISO STANDARDS).	
DIMENSIONS: mm	TOLERANCES UNLESS OTHERWISE SPECIFIED: n, ISO 8015 0-PLC ± 0.2mm 1-PLC ± 2-PLC ± 3-PLC ± 4-PLC ± ANGLES ±2°
MATERIAL siehe Tabelle material_2	FINISH siehe Tabelle finish_spec_2

DWN C. Goetz 05JAN2004		APVD J. Hass 06JAN2004		NAME 1.5MM PIN HOUSING, 5-7POS., ASSY 1.5mm Stiftgehaeuse, 5-7pol., Assy	
CHK J. Granzow 06JAN2004		PRODUCT SPEC 108-18622		APPLICATION SPEC 114-18255	
SIZE A2	CAGE CODE 00779	DRAWING NO C-1718230	RESTRICTED TO -		WEIGHT 15g
CUSTOMER DRAWING		SCALE 2:1	SHEET 1 OF 1	REV A6	



Mouser Electronics

Authorized Distributor

Click to View Pricing, Inventory, Delivery & Lifecycle Information:

[TE Connectivity:](#)

[3-1718230-1](#)