

REVISIONS				
REV	DESCRIPTION	DATE	BY	APP'D
AH	REVISED PER ECR-25-253172	06OCT2025	CM	AN

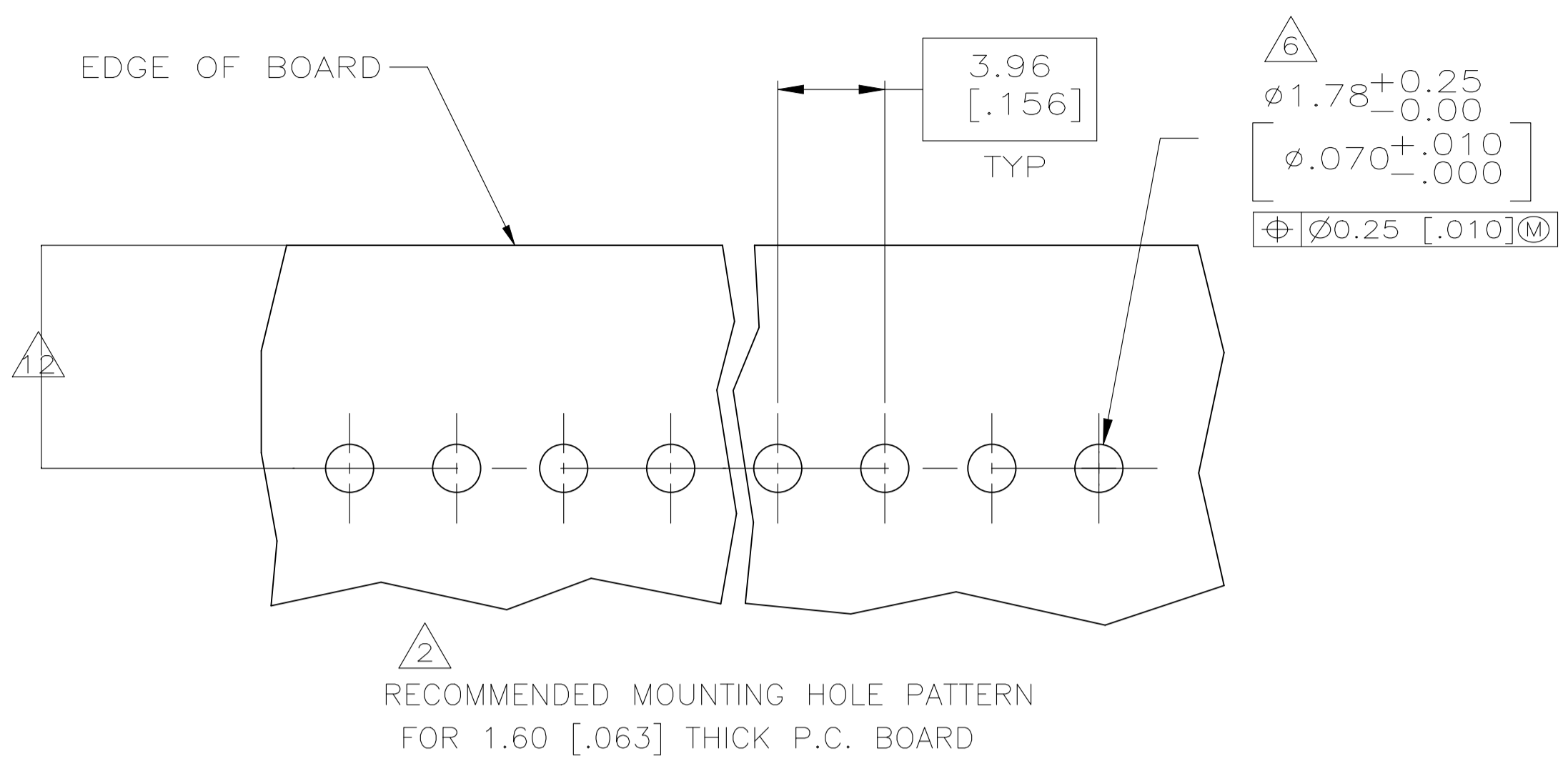

- 1 POST TO WITHSTAND 13 NEWTONS (3 LBS) MINIMUM AXIAL FORCE IN BOTH DIRECTIONS SHOWN WITHOUT DISLODGING.
- 2 TOLERANCES APPLY TO SOLDER SIDE OF BOARD.
- 3 MEASURED AT SURFACE \overline{A}
- 4 PLASTIC FLASH PERMITTED IN THIS AREA.
- 5 PARTS COMPLY WITH AMP SOLDERABILITY SPEC. NO. 109-11-2.
- 6 ONE HOLE MAY BE UNDERSIZED 1.65/1.52 [.065/.060] DIA. FOR ASSEMBLY RETENTION DURING WAVE SOLDERING.
- 7 MATERIAL: HEADER-THERMOPLASTIC POLYESTER GLASS-FILLED 94V-0 (NATURAL) POST-COPPER ALLOY (SEE NOTES 13 & 14 FOR PLATING)
- 8 COORDINATE DIMENSION APPLIES FROM CENTER OF ACTUAL FEATURE.
- 9 PLASTIC BURRS CAUSED BY CUT-OFF TOOLING ARE PERMITTED WITHIN THE MAXIMUM TOLERANCE ENVELOPE.
- 10 POST TO BE MEASURED WHEN STRIP IS HELD FLAT.
- 11 POST MUST WITHSTAND TWO 90° BENDS AGAINST EXTRUSION WITHOUT BREAKING.
- 12 DIMENSION SHOULD BE 4.45 [.175] MIN WHEN MATING WITH A MTA-156 CONNECTOR ASSEMBLY OR A SL-156 CONNECTOR ASSEMBLY.
- 13 PLATING: GOLD PLATE AREA, 0.00038 [.000015] GOLD OR 0.00008 [.000003] MIN GOLD FLASH OVER 0.00030 [.000012] PALLADIUM NICKEL, ONLY IN FUNCTIONAL CONTACT AREA AND OTHER AREAS WITH OPTIMIZED THICKNESS PER TE CONNECTIVITY'S DISCRETION, ALL SIDES, OVER NICKEL UNDERPLATE, 0.00127 [.000050] MIN, ALL SIDES AND ENTIRE LENGTH OF POST.
- 14 PLATING: BRIGHT TIN/LEAD (93/7) PLATE AREA, 0.00381-0.00889 [.000150-.000350] THICK, ALL FOUR SIDES 3.18 [.125] MINIMUM FOR -2 THRU -24. MATTE TIN PLATE AREA 0.00381-0.00889 [.000150-.000350] THICK ALL FOUR SIDES, 3.18 [.125] FOR -32 THRU -54.
- 15 OBSOLETE PARTS: OBSOLETE CIS STREAMLINING PER D.RENAUD/D.SINISI

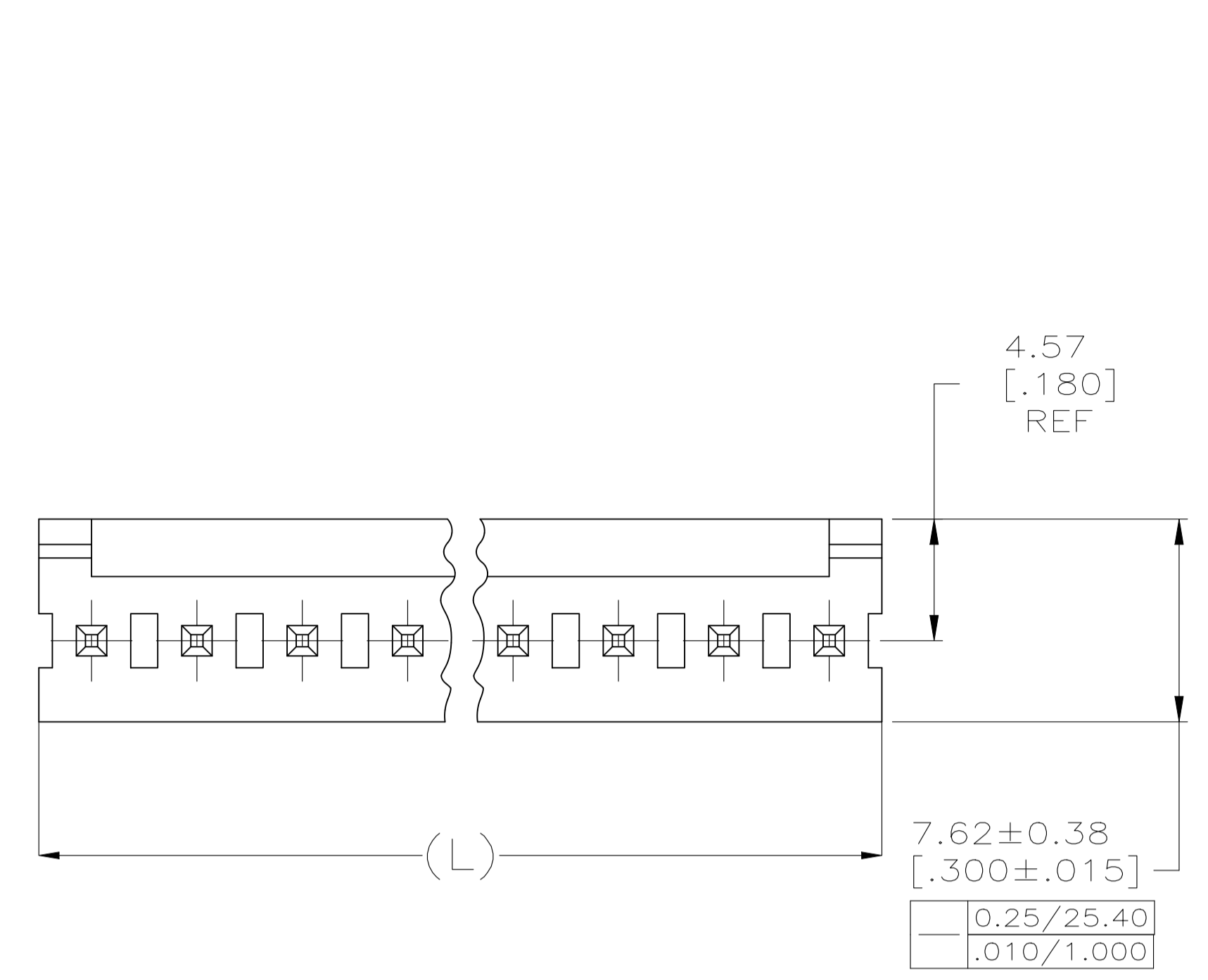
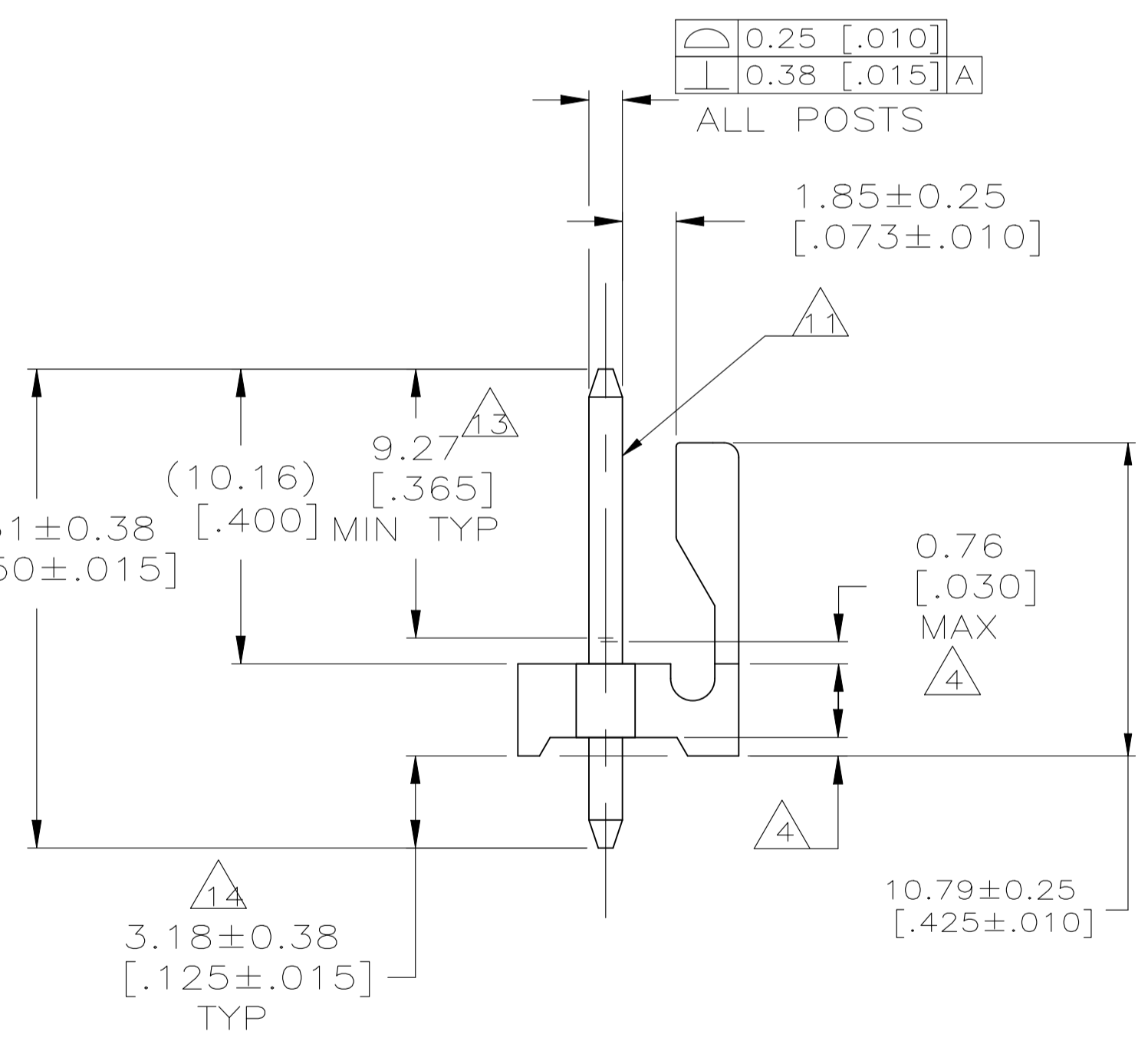
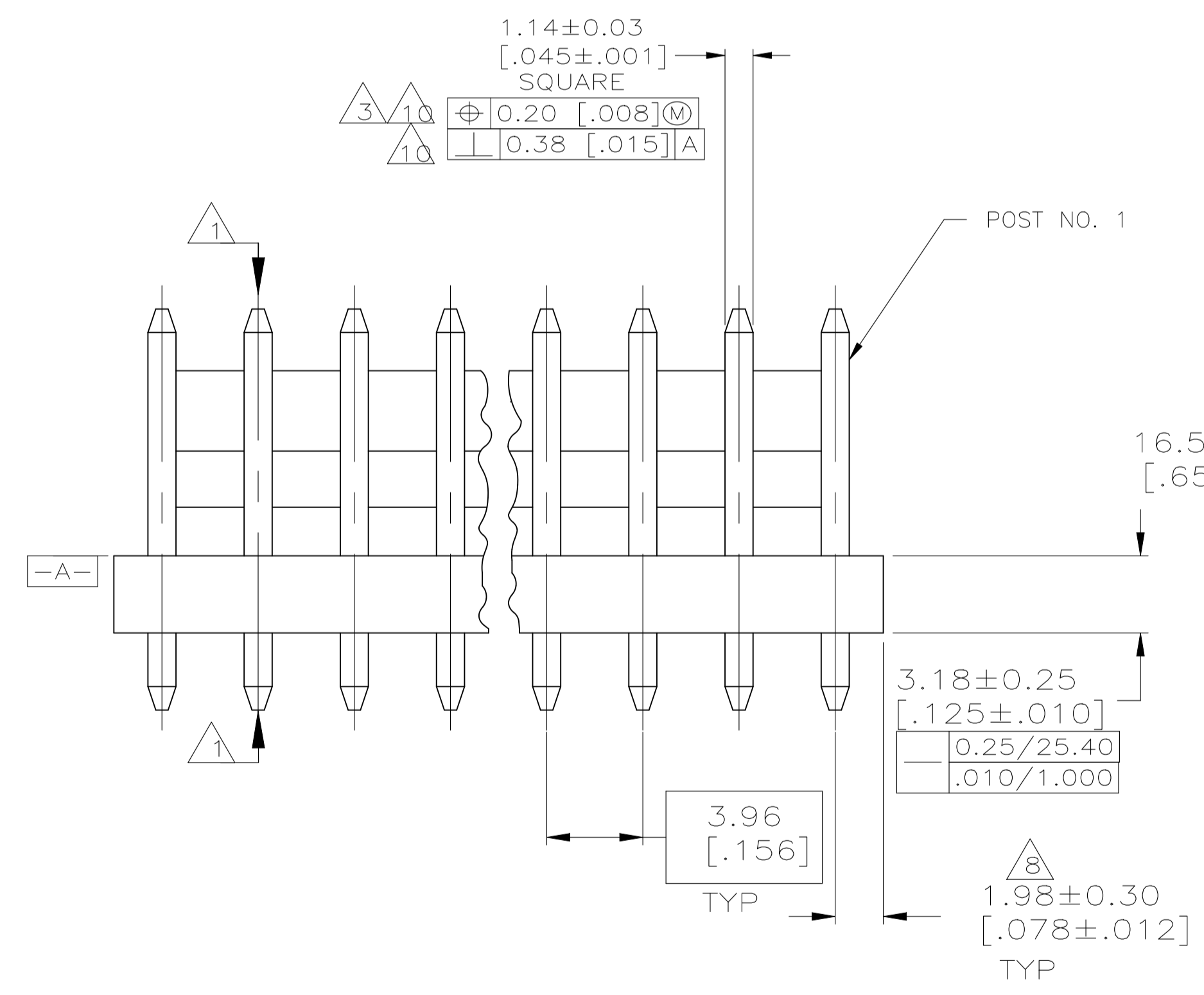

DIM (L)	NO.OF POSN	ASSEMBLY
95.10 [3.744]	24	5-641119-4
91.14 [3.588]	23	5-641119-3
87.17 [3.432]	22	5-641119-2
83.21 [3.276]	21	5-641119-1
79.25 [3.120]	20	5-641119-0
75.29 [2.964]	19	4-641119-9
71.32 [2.808]	18	4-641119-8
67.36 [2.652]	17	4-641119-7
63.40 [2.496]	16	4-641119-6
59.44 [2.340]	15	4-641119-5
55.47 [2.184]	14	4-641119-4
51.51 [2.028]	13	4-641119-3
47.55 [1.872]	12	4-641119-2
43.59 [1.716]	11	4-641119-1
39.62 [1.560]	10	4-641119-0
35.66 [1.404]	9	3-641119-9
31.70 [1.248]	8	3-641119-8
27.74 [1.092]	7	3-641119-7
23.77 [.936]	6	3-641119-6
19.81 [.780]	5	3-641119-5
15.85 [.624]	4	3-641119-4
11.89 [.468]	3	3-641119-3
7.92 [.312]	2	3-641119-2
DIM (L)	NO.OF POSN	ASSEMBLY

DIM (L)	NO.OF POSN	ASSEMBLY
95.10 [3.744]	24	2-641119-4
91.14 [3.588]	23	2-641119-3
87.17 [3.432]	22	2-641119-2
83.21 [3.276]	21	2-641119-1
79.25 [3.120]	20	2-641119-0
75.29 [2.964]	19	1-641119-9
71.32 [2.808]	18	1-641119-8
67.36 [2.652]	17	1-641119-7
63.40 [2.496]	16	1-641119-6
59.44 [2.340]	15	1-641119-5
55.47 [2.184]	14	1-641119-4
51.51 [2.028]	13	1-641119-3
47.55 [1.872]	12	1-641119-2
43.59 [1.716]	11	1-641119-1
39.62 [1.560]	10	1-641119-0
35.66 [1.404]	9	641119-9
31.70 [1.248]	8	641119-8
27.74 [1.092]	7	641119-7
23.77 [.936]	6	641119-6
19.81 [.780]	5	641119-5
15.85 [.624]	4	641119-4
11.89 [.468]	3	641119-3
7.92 [.312]	2	641119-2
DIM (L)	NO.OF POSN	ASSEMBLY

1-641119-7	SUPERSEDED BY 4-641119-7
1-641119-8	SUPERSEDED BY 4-641119-8
1-641119-9	SUPERSEDED BY 4-641119-9
2-641119-1	SUPERSEDED BY 5-641119-1
2-641119-2	SUPERSEDED BY 5-641119-2
2-641119-3	SUPERSEDED BY 5-641119-3

METRIC

THIS DRAWING IS A CONTROLLED DOCUMENT.

DIMENSIONS: mm [INCHES]

TOLERANCES UNLESS OTHERWISE SPECIFIED:

0. PLC	±
1. PLC	±
2. PLC	± 0.13 [0.005]
3. PLC	±
4. PLC	±
ANGLES	±

MATERIAL: \overline{A} FINISH: \overline{A}

APPROVED: D. BOSSI 07-NOV-2002

NAME: MTA-156 HEADER ASSEMBLY, FRICTION LOCK, STRAIGHT, .045 SQ POST, .000015 GOLD

SIZE: A1 CAGE CODE: 00779 DRAWING NO: 641119

WEIGHT: -

CUSTOMER DRAWING

SCALE: 5:1 SHEET: 1 OF 1 REV: AH