

1. INTRODUCTION

This instruction sheet covers the installation and operation of the AGASTAT\* SSF Series Universal Timers. Read these instructions thoroughly before installing the timers.

**NOTE** *Dimensions in this instruction sheet are in millimeters [with inches in brackets]. Figures are not drawn to scale.*

2. DESCRIPTION

Each timer is an accurate instrument using a minimum of moving parts. When satisfactory performance cannot be restored, the unit should be returned to TE Connectivity for repair or replacement.

3. MOUNTING DIMENSIONS

Refer to Figure 1 for mounting dimensions.

4. WIRING (Figure 2)

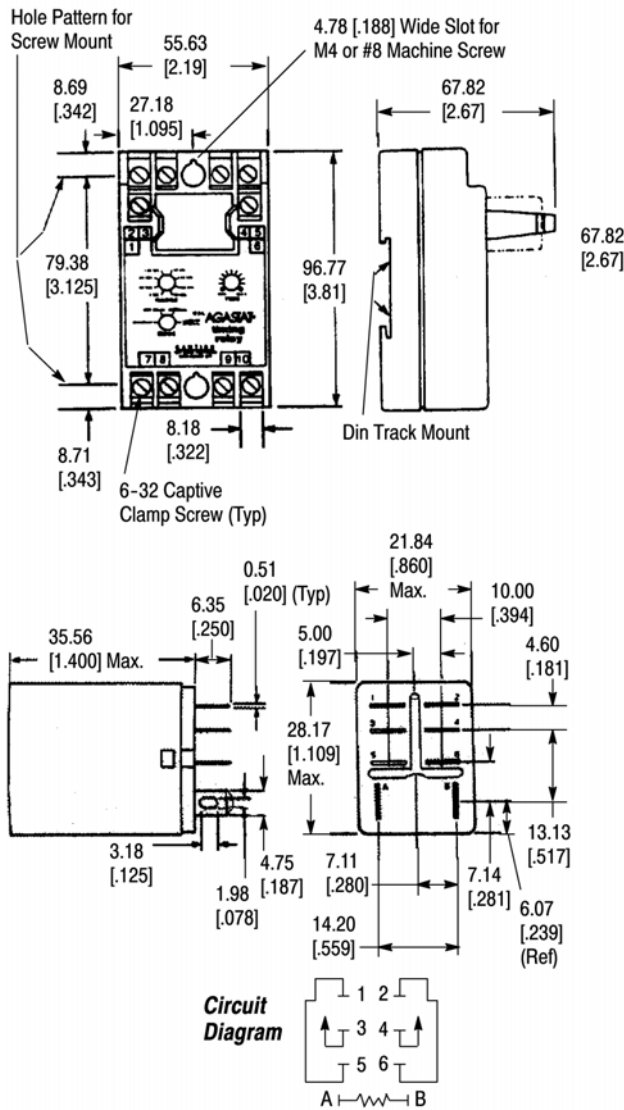
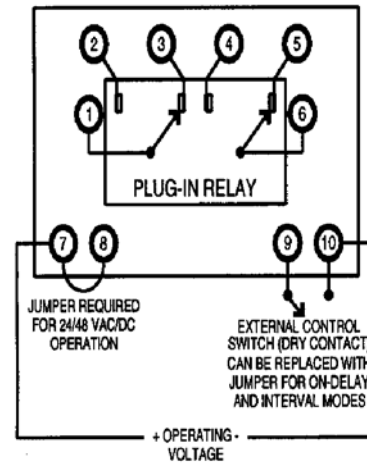

Figure 1



CODE LETTER	OPERATING VOLTAGE (+10%, -15%)
A	120 Vac 50/60 Hz
B	240 Vac 50/50 Hz
E	24 Vac 50/60 Hz
F	48 Vac 50/60 Hz
N	48 Vdc
O	24 Vdc
P	125 Vdc
X	Without factory installed relay. Voltage determined by customer supplied relay. Only relays that operate on the above listed nominal voltages should be used. Timer operation using other voltages is not recommended.

Figure 2

5. OPERATION

With power removed from timer, set desired mode and range with appropriate controls on face of timer.

**NOTE** *Timer mode and range will not change unless power is removed.*

Install relay if not supplied by factory. Apply operating voltage to timer. Set timer delay with “time” adjust control on face of timers.

## 6. OPERATIONAL MODES

### 6.1. Type 1: On-Delay (Figure 3)

Time delay initiated upon application of operating voltage and closure of the control path. If both are maintained, output relay transfers upon expiration of time delay. If either is interrupted, timer will reset and, if the time delay has also expired, the output relay will release.

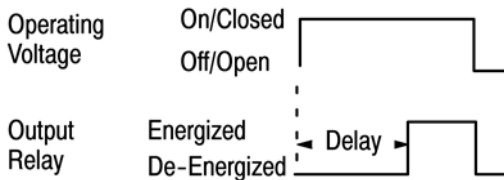

Figure 3

### 6.2. Type 2: Off-Delay (Figure 4)

Operating voltage applied continuously. Output relay transfers upon closure of control path. Time delay initiated upon opening of control path. If control path remains open, output relay releases upon expiration of time delay. If control path is re-closed prior to expiration of time delay, timer will reset.

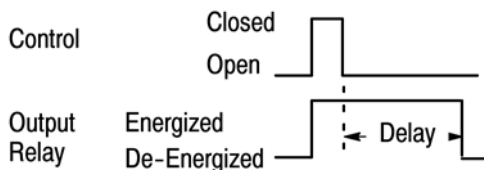

Figure 4

### 6.3. Type 3: Interval (Figure 5)

Output relay transfers and time delay is initiated upon application of operating voltage and closure of the control path. If both are maintained, output relay will release upon expiration of time delay. If either is interrupted prior to expiration of time delay, output relay will release and timer will reset. If either is interrupted after expiration of time delay, timer will reset.

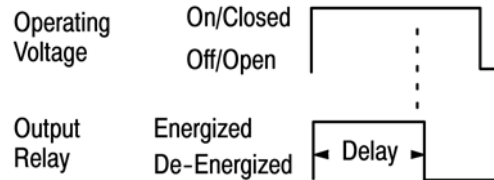

Figure 5

### 6.4. Type 4: Latching Interval (Figure 6)

Operating voltage applied continuously. Output relay transfers and time delay is initiated upon closure of control path. Opening and closing of control path prior to the expiration of the time delay will not reset the timer. Upon expiration of the time delay, output relay releases. If the control path is not open when the time delay expires, it must be opened before the next cycle can be initiated.

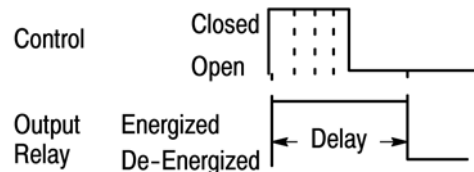

Figure 6

## 7. QUALIFICATIONS

The SSF Series Universal Timers are recognized components by Underwriters Laboratories Inc. (UL) in File No. E15631 and certified to the Canadian Standards Association (CSA) in File No. LR29186.

## 8. REVISION SUMMARY

Since the previous version of this document, the following changes were made:

- Removed paragraph from Section 5.
- Changed company name and logo.

# Mouser Electronics

Authorized Distributor

Click to View Pricing, Inventory, Delivery & Lifecycle Information:

[TE Connectivity:](#)

[SSFR90P](#) [SSFR90A](#) [SSFR90X](#) [SSFR90B](#) [SSFR90N](#) [SSFR90O](#)