

- ▶ Voltage monitoring in 3-phase mains
- ▶ Monitoring of phase sequence and phase failure
- ▶ Detection of reverse voltage
- ▶ Connection of neutral wire optional
- ▶ Supply voltage = measuring voltage
- ▶ 2 change-over contacts
- ▶ Width 22.5mm
- ▶ Industrial design



## Technical data

### 1. Functions

Monitoring of phase sequence, phase failure and detection of return voltage (by means of evaluating the asymmetry)

### 2. Time ranges

	Adjustment range
Start-up suppression time:	fixed, max. 500ms
Tripping delay:	fixed, max. 350ms

### 3. Indicators

Green LED ON:	indication of supply voltage
Yellow LED ON/OFF:	indication of relay output

### 4. Mechanical design

Self-extinguishing plastic housing, IP rating IP40  
 Mounted on DIN-Rail TS 35 according to EN 50022  
 Mounting position: any  
 Shockproof terminal connection according to VBG 4 (PZ1 required), IP rating IP20  
 Tightening torque: max. 1Nm  
 Terminal capacity:  
 1 x 0.5 to 2.5mm<sup>2</sup> with/without multicore cable end  
 1 x 4mm<sup>2</sup> without multicore cable end  
 2 x 0.5 to 1.5mm<sup>2</sup> with/without multicore cable end  
 2 x 2.5mm<sup>2</sup> flexible without multicore cable end

### 5. Input circuit

Supply voltage:		
3(N)~ 115/66V	terminals (N)-L1-L2-L3 (= measuring voltage)	(G2PF115VS02)
3(N)~ 230/132V	terminals (N)-L1-L2-L3 (= measuring voltage)	(G2PF230VS02)
3(N)~ 400/230V	terminals (N)-L1-L2-L3 (= measuring voltage)	(G2PF400VS02)
Tolerance:		
3(N)~ 115/66V	3(N)~ 99 to 132V	(G2PF115VS02)
3(N)~ 230/132V	3(N)~ 198 to 264V	(G2PF230VS02)
3(N)~ 400/230V	3(N)~ 342 to 457V	(G2PF400VS02)
Rated frequency:	48 to 63Hz	
Rated consumption:		
3(N)~ 115/66V	3VA	(G2PF115VS02)
3(N)~ 230/132V	6VA	(G2PF230VS02)
3(N)~ 400/230V	9VA	(G2PF400VS02)
Duration of operation:	100%	
Reset time:	<100ms	
Residual ripple for DC:	-	
Drop-out voltage:	>20% of the supply voltage	
Overvoltage category:	III (according to IEC 60664-1)	
Rated surge voltage:	4kV	

### 6. Output circuit

2 potential free change-over contacts	
Rated voltage:	250V AC
Switching capacity (distance <5mm):	750VA (3A / 250V AC)
Switching capacity (distance >5mm):	1250VA (5A / 250V AC)
Fusing:	5A fast acting
Mechanical life:	20 x 10 <sup>6</sup> operations
Electrical life:	2 x 10 <sup>5</sup> operations at 1000VA resistive load
Switching frequency:	max. 60/min at 100VA resistive load max. 6/min at 1000VA resistive load (according to IEC 947-5-1)
Overvoltage category:	III (according to IEC 60664-1)
Rated surge voltage:	4kV

### 7. Measuring circuit

Measured variable:	AC Sinus, 48 to 63Hz	
Input:		
3(N)~ 115/66V	terminals (N)-L1-L2-L3 (= supply voltage)	(G2PF115VS02)
3(N)~ 230/132V	terminals (N)-L1-L2-L3 (= supply voltage)	(G2PF230VS02)
3(N)~ 400/230V	terminals (N)-L1-L2-L3 (= supply voltage)	(G2PF400VS02)
Overload capacity:		
3(N)~ 115/66V	3(N)~ 132/76V	(G2PF115VS02)
3(N)~ 230/132V	3(N)~ 264/152V	(G2PF230VS02)
3(N)~ 400/230V	3(N)~ 457/264V	(G2PF400VS02)
Input resistance:		
3(N)~ 115/66V	5kΩ	(G2PF115VS02)
3(N)~ 230/132V	10kΩ	(G2PF230VS02)
3(N)~ 400/230V	15kΩ	(G2PF400VS02)
Asymmetry:	fixed, typ. 30%	
Overvoltage category:	III (according to IEC 60664-1)	
Rated surge voltage:	4kV	

### 8. Accuracy

Base accuracy:	-
Frequency response:	-
Adjustment accuracy:	-
Repetition accuracy:	-
Voltage influence:	-
Temperature influence:	-

### 9. Ambient conditions

Ambient temperature:	-25 to +55°C (according to IEC 68-1) -25 to +40°C (according to UL 508)
Storage temperature:	-25 to +70°C
Transport temperature:	-25 to +70°C
Relative humidity:	15% to 85% (according to IEC 721-3-3 class 3K3)
Pollution degree:	3 (according to IEC 60664-1)
Vibration resistance:	10 to 55Hz 0.35mm (according to IEC 68-2-6)
Shock resistance:	15g 11ms (according to IEC 68-2-27)

## ► Functions

### Phase sequence monitoring

When all the phases are connected in the correct sequence and the measured asymmetry is less than the fixed value, the output relays switch into on-position (yellow LED illuminated). When the phase sequence changes, the output relays switch into off-position (yellow LED not illuminated).

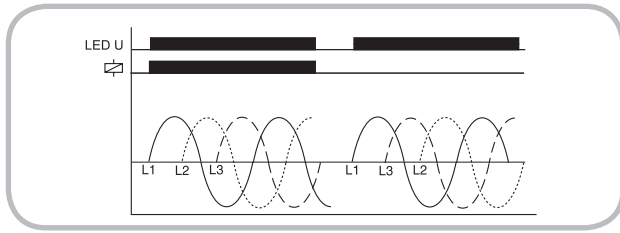

### Phase failure monitoring

When one of the three phases fails, the output relays switch into off-position (yellow LED not illuminated).

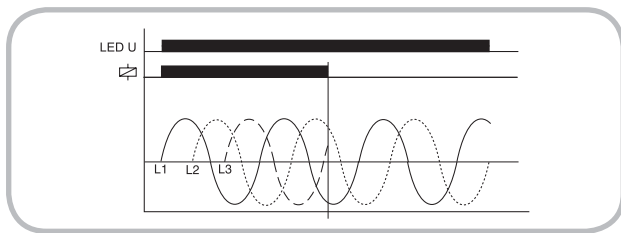

### Detection of reverse voltage (by means of evaluation of asymmetry)

The output relays switch into off-position (yellow LED not illuminated) when the asymmetry between the phase voltages exceeds the fixed value of the asymmetry.

An asymmetry caused by the reverse voltage of a consumer (e.g. a motor which continues to run on two phases only) does not effect the disconnection.

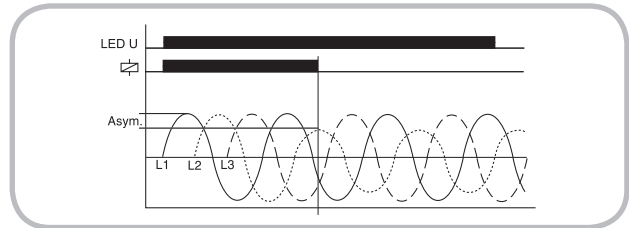

## ► Connections

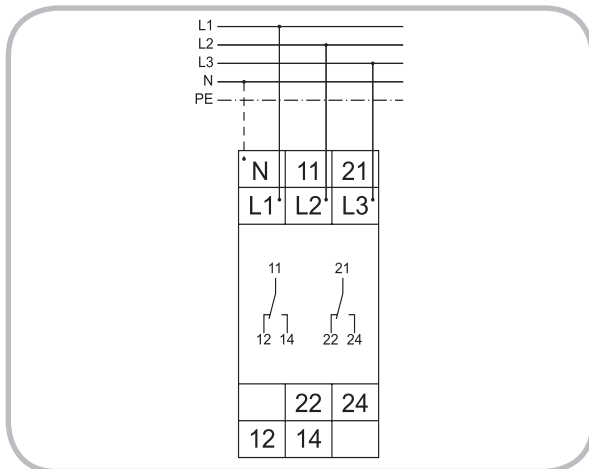

## ► Dimensions

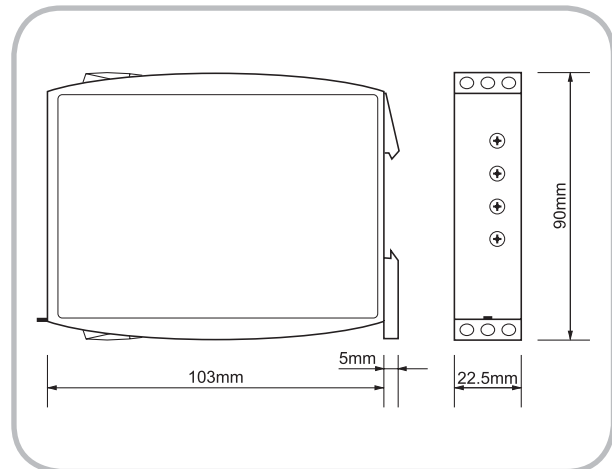

Subject to alterations and errors