

CDx4HC240, CDx4HCT240, CD74HC241, CDx4HCT241, CDx4HC244, CDx4HCT244

High-Speed CMOS Logic Octal Buffer/Line Drivers, Three-State

1 Features

- HC/HCT240 Inverting
- HC/HCT241 Non-inverting
- HC/HCT244 Non-inverting
- Typical propagation delay = 8ns at $V_{CC} = 5\text{ V}$, $C_L = 15\text{ pF}$, $T_A = 25^\circ\text{C}$ for HC240
- Three-state outputs
- Buffered inputs
- High-current bus driver outputs
- Fanout (over temperature range)
 - Standard outputs: 10 LSTTL loads
 - Bus driver outputs: 15 LSTTL loads
- Wide operating temperature range: -55°C to 125°C
- Balanced propagation delay and transition times
- Significant power reduction compared to LSTTL Logic ICs
- HC types:
 - 2 V to 6 V operation
 - High noise immunity: $N_{IL} = 30\%$, $N_{IH} = 30\%$ of V_{CC} at $V_{CC} = 5\text{ V}$
- HCT types:
 - 4.5 V to 5.5 V operation
 - Direct LSTTL input logic compatibility, $V_{IL} = 0.8\text{ V}$ (max), $V_{IH} = 2\text{ V}$ (min)
 - CMOS input compatibility, $I_I \leq 1\mu\text{A}$ at V_{OL} , V_{OH}

2 Description

The 'HC240 and 'HCT240 are inverting three-state buffers having two active-low output enables. The CD74HC241, 'HCT241, 'HC244 and 'HCT244 are non-inverting three-state buffers that differ only in that the 241 has one active-high and one active-low output enable, and the 244 has two active-low output enables. All three types have identical pinouts.

Package Information

PART NUMBER	PACKAGE ⁽¹⁾	BODY SIZE (NOM)
CD74HC240	M (SOIC, 20)	12.80 mm × 7.50 mm
	E (PDIP, 20)	25.40 mm × 6.35 mm
CD54HC240	F (CDIP, 20)	26.92 mm × 6.92 mm
CD74HCT240	M (SOIC, 20)	12.80 mm × 7.50 mm
	E (PDIP, 20)	25.40 mm × 6.35 mm
	PW (TSSOP, 20)	6.50 mm × 4.40 mm
CD54HCT240	F (CDIP, 20)	26.92 mm × 6.92 mm
CD74HC241	M (SOIC, 20)	12.80 mm × 7.50 mm
	E (PDIP, 20)	25.40 mm × 6.35 mm
CD74HCT241	M (SOIC, 20)	12.80 mm × 7.50 mm
	E (PDIP, 20)	25.40 mm × 6.35 mm
CD54HCT241	F (CDIP, 20)	26.92 mm × 6.92 mm
CD74HC244	M (SOIC, 20)	12.80 mm × 7.50 mm
	E (PDIP, 20)	25.40 mm × 6.35 mm
CD54HC244	F (CDIP, 20)	26.92 mm × 6.92 mm
CD74HCT244	M (SOIC, 20)	12.80 mm × 7.50 mm
	E (PDIP, 20)	25.40 mm × 6.35 mm
CD54HCT244	F (CDIP, 20)	26.92 mm × 6.92 mm

(1) For all available packages, see the orderable addendum at the end of the data sheet.

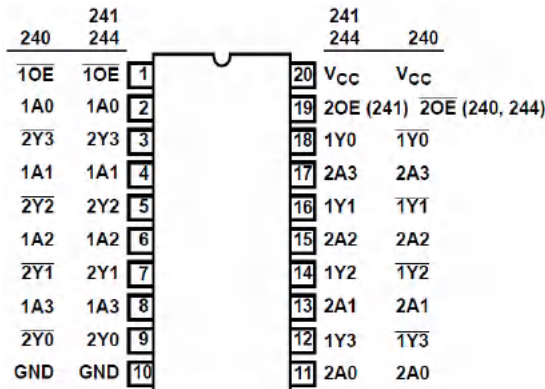

Pinout Diagram



Table of Contents

1 Features	1	7 Detailed Description	13
2 Description	1	7.1 Overview.....	13
3 Revision History	2	7.2 Functional Block Diagram.....	13
4 Pin Configuration and Functions	3	8 Power Supply Recommendations	15
5 Specifications	4	9 Layout	15
5.1 Absolute Maximum Ratings ⁽¹⁾	4	9.1 Layout Guidelines.....	15
5.2 Recommended Operating Conditions.....	4	10 Device and Documentation Support	16
5.3 Thermal Information.....	4	10.1 Receiving Notification of Documentation Updates..	16
5.4 Electrical Characteristics '240.....	5	10.2 Support Resources.....	16
5.5 Electrical Characteristics '241.....	6	10.3 Trademarks.....	16
5.6 Electrical Characteristics '244.....	7	10.4 Electrostatic Discharge Caution.....	16
5.7 Switching Characteristics '240.....	8	10.5 Glossary.....	16
5.8 Switching Characteristics '241.....	8	11 Mechanical, Packaging, and Orderable	
5.9 Switching Characteristics '244.....	9	Information	16
6 Parameter Measurement Information	11		

3 Revision History

NOTE: Page numbers for previous revisions may differ from page numbers in the current version.

Changes from Revision E (October 2004) to Revision F (February 2022)	Page
• Updated the numbering, formatting, tables, figures, and cross-references throughout the document to reflect modern data sheet standards.....	1

Changes from Revision F (February 2022) to Revision G (October 2022)	Page
• Increased R θ JA for packages: DW (73 to 109.1); DB (82 to 122.7); N (67 to 84.6); NS (64 to 113.4); PW (108 to 131.8).....	4

4 Pin Configuration and Functions

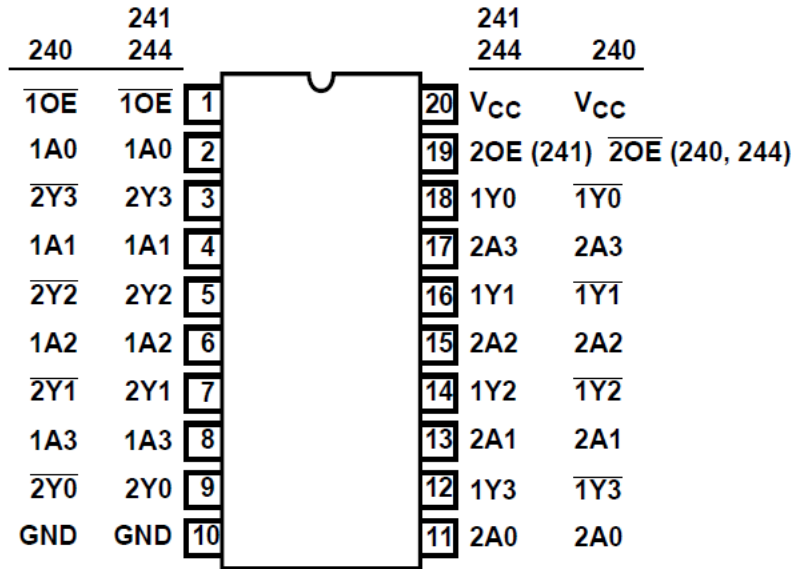

J, N, DW, or PW package
20-Pin CDIP, PDIP, SOIC, or TSSOP
Top View

5 Specifications

5.1 Absolute Maximum Ratings⁽¹⁾

			MIN	MAX	UNIT
V _{CC}	Supply voltage		-0.5	7	V
I _{IK}	Input clamp diode current	For V _I < -0.5 V or V _I > V _{CC} + 0.5 V		±20	mA
I _{OK}	Output clamp diode current	For V _O < -0.5 V or V _O > V _{CC} + 0.5 V		±20	mA
I _O	Drain current, per output	For -0.5 V < V _O < V _{CC} + 0.5 V		±35	mA
I _O	Output source or sink current per output pin	For V _O > -0.5 V or V _O < V _{CC} + 0.5 V		±25	mA
I _{CC}	Continuous current through V _{CC} or GND			±70	mA
T _J	Junction temperature			150	°C
T _{stg}	Storage temperature range		-65	150	°C
	Lead temperature (Soldering 10s) (SOIC - lead tips only)			300	°C

(1) Stresses beyond those listed under *absolute maximum ratings* may cause permanent damage to the device. These are stress ratings only and functional operation of the device at these or any other conditions beyond those indicated under *recommended operating conditions* is not implied. Exposure to absolute-maximum-rated conditions for extended periods may affect device reliability.

5.2 Recommended Operating Conditions

			MIN	MAX	UNIT
V _{CC}	Supply voltage range	HC types	2	6	V
		HCT types	4.5	5.5	
V _I , V _O	Input or output voltage		0	V _{CC}	V
t _t	Input rise and fall time	2 V		1000	ns
		4.5 V		500	
		6 V		400	
T _A	Temperature range		-55	125	°C

5.3 Thermal Information

THERMAL METRIC		DW (SOIC)	DB (SSOP)	N (PDIP)	NS (SO)	PW (TSSOP)	UNIT
		20 PINS	20 PINS	20 PINS	20 PINS	20 PINS	
R _{θJA}	Junction-to-ambient thermal resistance ⁽¹⁾	109.1	122.7	84.6	113.4	131.8	°C/W
R _{θJC (top)}	Junction-to-case (top) thermal resistance	76	81.6	72.5	78.6	72.2	°C/W
R _{θJB}	Junction-to-board thermal resistance	77.6	77.5	65.3	78.4	82.8	°C/W
Ψ _{JT}	Junction-to-top characterization parameter	51.5	46.1	55.3	47.1	21.5	°C/W
Ψ _{JB}	Junction-to-board characterization parameter	77.1	77.1	65.2	78.1	82.4	°C/W
R _{θJC (bot)}	Junction-to-case (bottom) thermal resistance	N/A	N/A	N/A	N/A	N/A	°C/W

(1) For more information about traditional and new thermal metrics, see the [Semiconductor and IC package thermal metrics](#) application report.

5.4 Electrical Characteristics '240

PARAMETER	TEST CONDITIONS ⁽²⁾	V _{CC} (V)	25°C			–40°C to 85°C		–55°C to 125°C		UNIT	
			MIN	TYP	MAX	MIN	MAX	MIN	MAX		
HC TYPES											
V _{IH}	High level input voltage		2	1.5		1.5		1.5		V	
			4.5	3.15		3.15		3.15			
			6	4.2		4.2		4.2			
V _{IL}	Low level input voltage		2		0.5		0.5		0.5	V	
			4.5		1.35		1.35		1.35		
			6		1.8		1.8		1.8		
V _{OH}	High level output voltage	I _{OH} = – 20 μA	2	1.9		1.9		1.9		V	
		I _{OH} = – 20 μA	4.5	4.4		4.4		4.4			
		I _{OH} = – 20 μA	6	5.9		5.9		5.9			
	High level output voltage	I _{OH} = – 6 mA	4.5	3.98		3.84		3.7			
		I _{OH} = – 7.8 mA	6	5.48		5.34		5.2			
V _{OL}	Low level output voltage	I _{OL} = 20 μA	2		0.1		0.1		0.1	V	
		I _{OL} = 20 μA	4.5		0.1		0.1		0.1		
		I _{OL} = 20 μA	6		0.1		0.1		0.1		
	Low level output voltage	I _{OL} = 6 mA	4.5		0.26		0.33		0.4		
		I _{OL} = 7.8 mA	6		0.26		0.33		0.4		
I _I	Input leakage current	V _I = V _{CC} or GND	6		±0.1		±1		±1	μA	
I _{CC}	Supply current	V _I = V _{CC} or GND	6		8		80		160	μA	
I _{OZ}	Three-state leakage current		6		±0.5		±0.5		±10	μA	
HCT TYPES											
V _{IH}	High level input voltage		4.5 to 5.5	2			2		2	V	
V _{IL}	Low level input voltage		4.5 to 5.5		0.8		0.8		0.8	V	
V _{OH}	High level output voltage	V _{OH} = – 20 μA	4.5	4.4		4.4		4.4		V	
	High level output voltage	V _{OH} = – 6 mA	4.5	3.98		3.84		3.7			
V _{OL}	Low level output voltage	V _{OL} = 20 μA	4.5		0.1		0.1		0.1	V	
	Low level output voltage	V _{OL} = 6 mA	4.5		0.26		0.33		0.4		
I _I	Input leakage current	V _I = V _{CC} or GND	5.5		±0.1		±1		±1	μA	
I _{CC}	Supply current	V _I = V _{CC} or GND	5.5		8		80		160	μA	
I _{OZ}	Three-state leakage current		5.5		±0.5		±5		±10	μA	
ΔI _{CC} ⁽¹⁾	Additional supply current per input pin	nA0 - A3 inputs held at V _{CC} – 2.1	4.5 to 5.5		100	540		675		735	μA
		1 $\overline{O}E$ inputs held at V _{CC} – 2.1	4.5 to 5.5		100	252		315		343	μA
		2 $\overline{O}E$ inputs held at V _{CC} – 2.1	4.5 to 5.5		100	252		315		343	μA

(1) For dual-supply systems theoretical worst case (V_I = 2.4 V, V_{CC} = 5.5 V) specification is 1.8 mA.

(2) V_I = V_{IH} or V_{IL}, unless otherwise noted.

5.5 Electrical Characteristics '241

PARAMETER	TEST CONDITIONS ⁽²⁾	V _{CC} (V)	25°C			–40°C to 85°C		–55°C to 125°C		UNIT	
			MIN	TYP	MAX	MIN	MAX	MIN	MAX		
HC TYPES											
V _{IH}	High level input voltage		2	1.5		1.5		1.5		V	
			4.5	3.15		3.15		3.15			
			6	4.2		4.2		4.2			
V _{IL}	Low level input voltage		2		0.5		0.5		0.5	V	
			4.5		1.35		1.35		1.35		
			6		1.8		1.8		1.8		
V _{OH}	High level output voltage	I _{OH} = – 20 μA	2	1.9		1.9		1.9		V	
		I _{OH} = – 20 μA	4.5	4.4		4.4		4.4			
		I _{OH} = – 20 μA	6	5.9		5.9		5.9			
	High level output voltage	I _{OH} = – 6 mA	4.5	3.98		3.84		3.7			
		I _{OH} = – 7.8 mA	6	5.48		5.34		5.2			
V _{OL}	Low level output voltage	I _{OL} = 20 μA	2		0.1		0.1		0.1	V	
		I _{OL} = 20 μA	4.5		0.1		0.1		0.1		
		I _{OL} = 20 μA	6		0.1		0.1		0.1		
	Low level output voltage	I _{OL} = 6 mA	4.5		0.26		0.33		0.4		
		I _{OL} = 7.8 mA	6		0.26		0.33		0.4		
I _I	Input leakage current	V _I = V _{CC} or GND	6		±0.1		±1		±1	μA	
I _{CC}	Supply current	V _I = V _{CC} or GND	6		8		80		160	μA	
I _{OZ}	Three-state leakage current		6		±0.5		±0.5		±10	μA	
HCT TYPES											
V _{IH}	High level input voltage		4.5 to 5.5	2			2		2	V	
V _{IL}	Low level input voltage		4.5 to 5.5		0.8		0.8		0.8	V	
V _{OH}	High level output voltage	V _{OH} = – 20 μA	4.5	4.4		4.4		4.4		V	
	High level output voltage	V _{OH} = – 6 mA	4.5	3.98		3.84		3.7			
V _{OL}	Low level output voltage	V _{OL} = 20 μA	4.5		0.1		0.1		0.1	V	
	Low level output voltage	V _{OL} = 6 mA	4.5		0.26		0.33		0.4		
I _I	Input leakage current	V _I = V _{CC} or GND	5.5		±0.1		±1		±1	μA	
I _{CC}	Supply current	V _I = V _{CC} or GND	5.5		8		80		160	μA	
I _{OZ}	Three-state leakage current		5.5		±0.5		±5		±10	μA	
ΔI _{CC} ⁽¹⁾	Additional supply current per input pin	nA0 - A3 inputs held at V _{CC} – 2.1	4.5 to 5.5		100	252		315		343	μA
		1 $\overline{O}E$ inputs held at V _{CC} – 2.1	4.5 to 5.5		100	252		315		343	μA
		2 $\overline{O}E$ inputs held at V _{CC} – 2.1	4.5 to 5.5		100	540		675		735	μA

(1) For dual-supply systems theoretical worst case (V_I = 2.4 V, V_{CC} = 5.5 V) specification is 1.8 mA.

(2) V_I = V_{IH} or V_{IL}, unless otherwise noted.

5.6 Electrical Characteristics '244

PARAMETER	TEST CONDITIONS ⁽²⁾	V _{CC} (V)	25°C			–40°C to 85°C		–55°C to 125°C		UNIT	
			MIN	TYP	MAX	MIN	MAX	MIN	MAX		
HC TYPES											
V _{IH}	High level input voltage		2	1.5		1.5		1.5		V	
			4.5	3.15		3.15		3.15			
			6	4.2		4.2		4.2			
V _{IL}	Low level input voltage		2		0.5		0.5		0.5	V	
			4.5		1.35		1.35		1.35		
			6		1.8		1.8		1.8		
V _{OH}	High level output voltage	I _{OH} = – 20 μA	2	1.9		1.9		1.9		V	
		I _{OH} = – 20 μA	4.5	4.4		4.4		4.4			
		I _{OH} = – 20 μA	6	5.9		5.9		5.9			
	High level output voltage	I _{OH} = – 6 mA	4.5	3.98		3.84		3.7			
		I _{OH} = – 7.8 mA	6	5.48		5.34		5.2			
V _{OL}	Low level output voltage	I _{OL} = 20 μA	2		0.1		0.1		0.1	V	
		I _{OL} = 20 μA	4.5		0.1		0.1		0.1		
		I _{OL} = 20 μA	6		0.1		0.1		0.1		
	Low level output voltage	I _{OL} = 6 mA	4.5		0.26		0.33		0.4		
		I _{OL} = 7.8 mA	6		0.26		0.33		0.4		
I _I	Input leakage current	V _I = V _{CC} or GND	6		±0.1		±1		±1	μA	
I _{CC}	Supply current	V _I = V _{CC} or GND	6		8		80		160	μA	
I _{OZ}	Three-state leakage current		6		±0.5		±0.5		±10	μA	
HCT TYPES											
V _{IH}	High level input voltage		4.5 to 5.5	2			2		2	V	
V _{IL}	Low level input voltage		4.5 to 5.5		0.8		0.8		0.8	V	
V _{OH}	High level output voltage	V _{OH} = – 20 μA	4.5	4.4		4.4		4.4		V	
	High level output voltage	V _{OH} = – 6 mA	4.5	3.98		3.84		3.7			
V _{OL}	Low level output voltage	V _{OL} = 20 μA	4.5		0.1		0.1		0.1	V	
	Low level output voltage	V _{OL} = 6 mA	4.5		0.26		0.33		0.4		
I _I	Input leakage current	V _I = V _{CC} or GND	5.5		±0.1		±1		±1	μA	
I _{CC}	Supply current	V _I = V _{CC} or GND	5.5		8		80		160	μA	
I _{OZ}	Three-state leakage current		5.5		±0.5		±5		±10	μA	
ΔI _{CC} ⁽¹⁾	Additional supply current per input pin	nA0 - A3 inputs held at V _{CC} – 2.1	4.5 to 5.5		100	252		315		343	μA
		1 $\overline{O}E$ inputs held at V _{CC} – 2.1	4.5 to 5.5		100	252		315		343	μA
		2 $\overline{O}E$ inputs held at V _{CC} – 2.1	4.5 to 5.5		100	252		315		343	μA

(1) For dual-supply systems theoretical worst case (V_I = 2.4 V, V_{CC} = 5.5 V) specification is 1.8 mA.

(2) V_I = V_{IH} or V_{IL}, unless otherwise noted.

5.7 Switching Characteristics '240

$C_L = 50 \text{ pF}$, Input t_r , $t_f = 6 \text{ ns}$

PARAMETER		V_{CC} (V)	25°C			–40°C to 85°C			–55°C to 125°C			UNIT
			MIN	TYP	MAX	MIN	TYP	MAX	MIN	TYP	MAX	
HC TYPES												
t_{PLH} , t_{PHL}	Propagation delay	2		100		125		150			ns	
	Data to outputs	4.5		8 ⁽³⁾		25		30				
		6		17		21		26				
t_{THL} , t_{TLH}	Output enable and disable time	2		150		190		225			ns	
		4.5		30		38		45				
		5		12								
t_{TLH} , t_{THL}	Output transition time	2		60		75		90			ns	
		4.5		12		15		18				
		6		10		13		15				
C_I	Input capacitance		10	10		10		10		10	pF	
C_O	Three-state output capacitance			20		20		20		20	pF	
C_{PD}	Power dissipation capacitance ^{(1) (2)}	5		38 ⁽³⁾							pF	
HCT TYPES												
t_{PHL} , t_{PLH}	Data to outputs	4.5		9 ⁽³⁾	22		28		33		ns	
t_{TLH} , t_{THL}	Output enable and disable times	4.5		30		38		45		ns		
t_{THL} , t_{TLH}	Output transition time	4.5		12		15		18		ns		
C_I	Input capacitance		10	10		10		10		pF		
C_{PD}	Power dissipation capacitance ^{(1) (2)}	5		40						pF		

(1) C_{PD} is used to determine the dynamic power consumption, per channel.

(2) $P_D = V_{CC}^2 f_i (C_{PD} + C_L)$ where f_i = input frequency, f_o = output frequency, C_L = output load capacitance, V_{CC} = supply voltage.

(3) $C_L = 15 \text{ pF}$ and $V_{CC} = 5 \text{ V}$.

5.8 Switching Characteristics '241

 $C_L = 50 \text{ pF}$, Input t_r , $t_f = 6 \text{ ns}$

PARAMETER		V_{CC} (V)	25°C			–40°C to 85°C			–55°C to 125°C			UNIT
			MIN	TYP	MAX	MIN	TYP	MAX	MIN	TYP	MAX	
HC TYPES												
t_{PLH} , t_{PHL}	Propagation delay Data to outputs	2		110		140		165	ns			
		4.5		9 ⁽³⁾		28		33				
		6		19		24		28				
t_{THL} , t_{TLH}	Output enable and disable time	2		150		190		225	ns			
		4.5		30		38		45				
		5		12								
t_{TLH} , t_{THL}	Output transition time	2		60		75		90	ns			
		4.5		12		15		18				
		6		10		13		15				
C_I	Input capacitance		10	10		10		10	pF			
C_O	Three-state output capacitance			20		20		20	pF			
C_{PD}	Power dissipation capacitance ^{(1) (2)}	5		34 ⁽³⁾					pF			
HCT TYPES												
t_{PHL} , t_{PLH}	Data to outputs	4.5		10 ⁽³⁾	25		31		38	ns		
t_{TLH} , t_{THL}	Output enable and disable times	4.5		30		38		45	ns			
t_{THL} , t_{TLH}	Output transition time	4.5		12		15		18	ns			
C_I	Input capacitance		10	10		10		10	pF			
C_{PD}	Power dissipation capacitance ^{(1) (2)}	5		38					pF			

(1) C_{PD} is used to determine the dynamic power consumption, per channel.

(2) $P_D = V_{CC}^2 f_i (C_{PD} + C_L)$ where f_i = input frequency, f_o = output frequency, C_L = output load capacitance, V_{CC} = supply voltage.

(3) $C_L = 15 \text{ pF}$ and $V_{CC} = 5 \text{ V}$.

5.9 Switching Characteristics '244

$C_L = 50$ pF, Input t_r , $t_f = 6$ ns

PARAMETER		V_{CC} (V)	25°C			–40°C to 85°C			–55°C to 125°C			UNIT
			MIN	TYP	MAX	MIN	TYP	MAX	MIN	TYP	MAX	
HC TYPES												
t_{PLH} , t_{PHL}	Propagation delay Data to outputs	2		110		140		165	ns			
		4.5		9 ⁽³⁾	22		28	33				
		6		19		24		28				
t_{THL} , t_{TLH}	Output enable and disable time	2		150		190		225	ns			
		4.5		30		38		45				
		5		12								
t_{TLH} , t_{THL}	Output transition time	2		60		75		90	ns			
		4.5		12		15		18				
		6		10		13		15				
C_I	Input capacitance		10	10		10		10	pF			
C_O	Three-state output capacitance			20		20		20	pF			
C_{PD}	Power dissipation capacitance ^{(1) (2)}	5		46 ⁽³⁾					pF			
HCT TYPES												
t_{PHL} , t_{PLH}	Data to outputs	4.5		10 ⁽³⁾	25		31		38	ns		
t_{TLH} , t_{THL}	Output enable and disable times	4.5		30		38		45	ns			
t_{THL} , t_{TLH}	Output transition time	4.5		12		15		18	ns			
C_I	Input capacitance		10	10		10		10	pF			
C_{PD}	Power dissipation capacitance ^{(1) (2)}	5		40					pF			

(1) C_{PD} is used to determine the dynamic power consumption, per channel.

(2) $P_D = V_{CC}^2 f_i (C_{PD} + C_L)$ where f_i = input frequency, f_o = output frequency, C_L = output load capacitance, V_{CC} = supply voltage.

(3) $C_L = 15$ pF and $V_{CC} = 5$ V.

6 Parameter Measurement Information

Phase relationships between waveforms were chosen arbitrarily. All input pulses are supplied by generators having the following characteristics: $PRR \leq 1 \text{ MHz}$, $Z_O = 50 \Omega$, $t_t < 6 \text{ ns}$.

For clock inputs, f_{max} is measured when the input duty cycle is 50%.

The outputs are measured one at a time with one input transition per measurement.

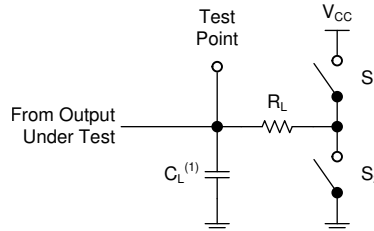

(1) C_L includes probe and test-fixture capacitance.

Figure 6-1. Load Circuit for 3-State Outputs

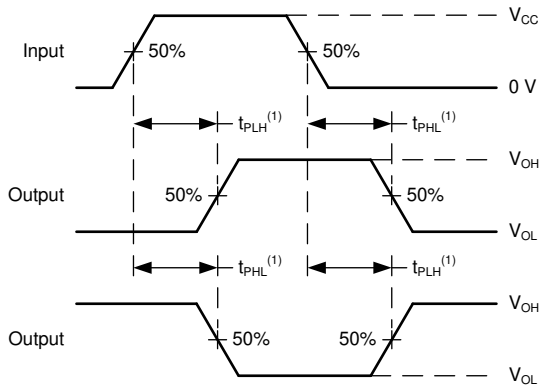

(1) The greater between t_{PLH} and t_{PHL} is the same as t_{pd} .

Figure 6-2. Voltage Waveforms, Propagation Delays for Standard CMOS Inputs

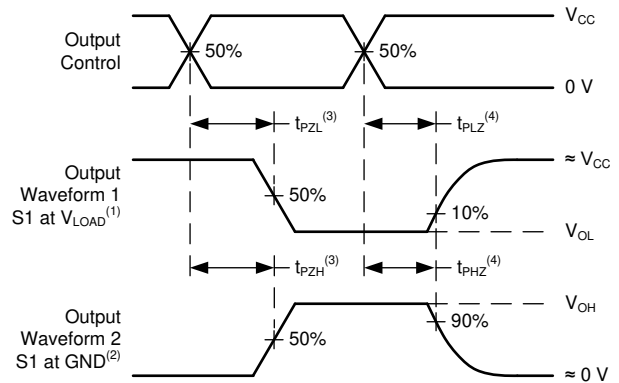

(1) S1 = CLOSED; S2 = OPEN.

(2) S1 = OPEN; S2 = CLOSED.

(3) t_{PLZ} and t_{PHZ} are the same as t_{dis} .

(4) t_{PZL} and t_{PZH} are the same as t_{en} .

Figure 6-3. Voltage Waveforms, Standard CMOS Inputs Propagation Delays

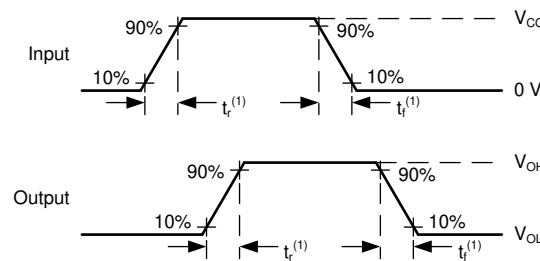

(1) The greater between t_r and t_f is the same as t_t .

Figure 6-4. Voltage Waveforms, Input and Output Transition Times for Standard CMOS Inputs

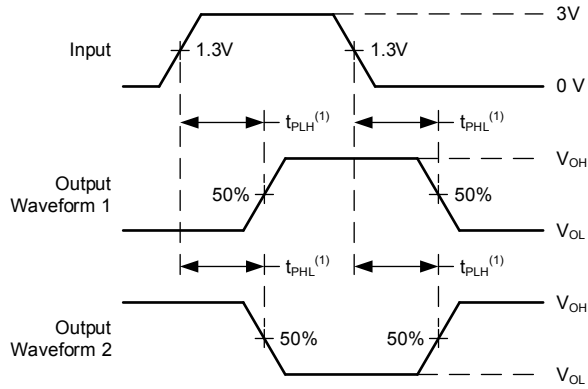

(1) The greater between t_{PLH} and t_{PHL} is the same as t_{pd} .

Figure 6-5. Voltage Waveforms, Propagation Delays for TTL-Compatible Inputs

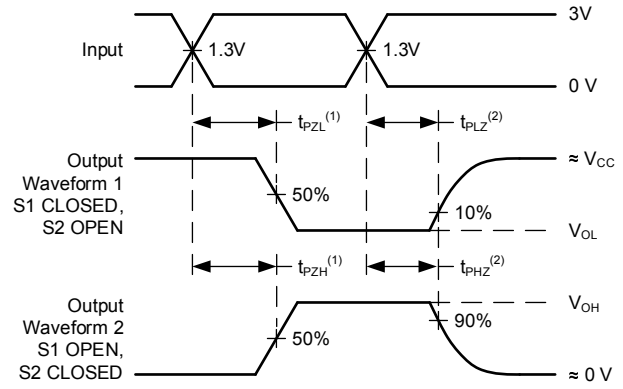

(1) t_{PLZ} and t_{PHZ} are the same as t_{dis} .

(2) t_{PZL} and t_{PZH} are the same as t_{en} .

Figure 6-6. Voltage Waveforms, TTL-Compatible CMOS Inputs Propagation Delays

7 Detailed Description

7.1 Overview

The 'HC240 and 'HCT240 are inverting three-state buffers having two active-low output enables. The CD74HC241, 'HCT241, 'HC244 and 'HCT244 are non-inverting threestate buffers that differ only in that the 241 has one activehigh and one active-low output enable, and the 244 has two active-low output enables. All three types have identical pinouts.

7.2 Functional Block Diagram

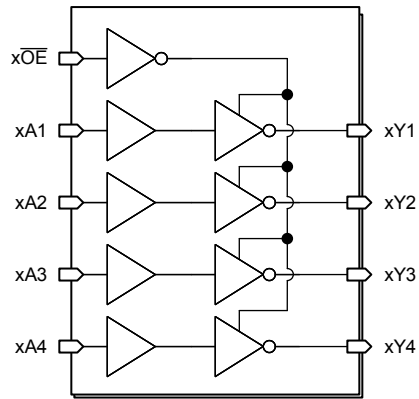

Figure 7-1. Functional Block Diagram '240

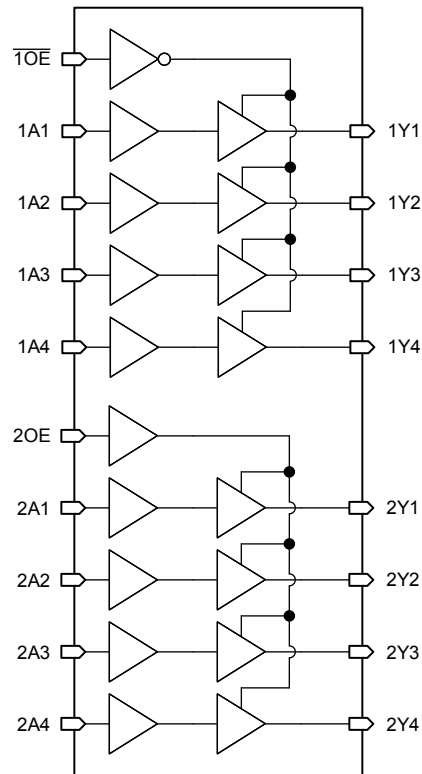

Figure 7-2. Functional Block Diagram '241

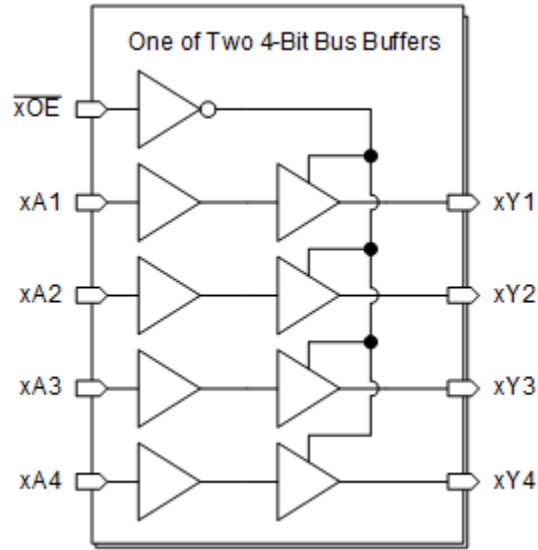

Figure 7-3. Functional Block Diagram '244

8 Power Supply Recommendations

The power supply can be any voltage between the minimum and maximum supply voltage rating located in the *Recommended Operating Conditions*. Each V_{CC} terminal should have a good bypass capacitor to prevent power disturbance. A 0.1- μF capacitor is recommended for this device. It is acceptable to parallel multiple bypass capacitors to reject different frequencies of noise. The 0.1- μF and 1- μF capacitors are commonly used in parallel. The bypass capacitor should be installed as close to the power terminal as possible for best results.

9 Layout

9.1 Layout Guidelines

When using multiple-input and multiple-channel logic devices, inputs must not ever be left floating. In many cases, functions or parts of functions of digital logic devices are unused; for example, when only two inputs of a triple-input AND gate are used or only 3 of the 4 buffer gates are used. Such unused input pins must not be left unconnected because the undefined voltages at the outside connections result in undefined operational states. All unused inputs of digital logic devices must be connected to a logic high or logic low voltage, as defined by the input voltage specifications, to prevent them from floating. The logic level that must be applied to any particular unused input depends on the function of the device. Generally, the inputs are tied to GND or V_{CC} , whichever makes more sense for the logic function or is more convenient.

10 Device and Documentation Support

TI offers an extensive line of development tools. Tools and software to evaluate the performance of the device, generate code, and develop solutions are listed below.

10.1 Receiving Notification of Documentation Updates

To receive notification of documentation updates, navigate to the device product folder on ti.com. Click on *Subscribe to updates* to register and receive a weekly digest of any product information that has changed. For change details, review the revision history included in any revised document.

10.2 Support Resources

TI E2E™ [support forums](#) are an engineer's go-to source for fast, verified answers and design help — straight from the experts. Search existing answers or ask your own question to get the quick design help you need.

Linked content is provided "AS IS" by the respective contributors. They do not constitute TI specifications and do not necessarily reflect TI's views; see TI's [Terms of Use](#).

10.3 Trademarks

TI E2E™ is a trademark of Texas Instruments.

All trademarks are the property of their respective owners.

10.4 Electrostatic Discharge Caution



This integrated circuit can be damaged by ESD. Texas Instruments recommends that all integrated circuits be handled with appropriate precautions. Failure to observe proper handling and installation procedures can cause damage.

ESD damage can range from subtle performance degradation to complete device failure. Precision integrated circuits may be more susceptible to damage because very small parametric changes could cause the device not to meet its published specifications.

10.5 Glossary

[TI Glossary](#) This glossary lists and explains terms, acronyms, and definitions.

11 Mechanical, Packaging, and Orderable Information

The following pages include mechanical, packaging, and orderable information. This information is the most current data available for the designated devices. This data is subject to change without notice and revision of this document. For browser-based versions of this data sheet, refer to the left-hand navigation.

PACKAGING INFORMATION

Orderable part number	Status (1)	Material type (2)	Package Pins	Package qty Carrier	RoHS (3)	Lead finish/ Ball material (4)	MSL rating/ Peak reflow (5)	Op temp (°C)	Part marking (6)
CD54HC240F3A	Active	Production	CDIP (J) 20	20 TUBE	No	SNPB	N/A for Pkg Type	-55 to 125	8407401RA CD54HC240F3A
CD54HC240F3A.A	Active	Production	CDIP (J) 20	20 TUBE	No	SNPB	N/A for Pkg Type	-55 to 125	8407401RA CD54HC240F3A
CD54HC244F	Active	Production	CDIP (J) 20	20 TUBE	No	SNPB	N/A for Pkg Type	-55 to 125	CD54HC244F
CD54HC244F.A	Active	Production	CDIP (J) 20	20 TUBE	No	SNPB	N/A for Pkg Type	-55 to 125	CD54HC244F
CD54HC244F3A	Active	Production	CDIP (J) 20	20 TUBE	No	SNPB	N/A for Pkg Type	-55 to 125	8409601RA CD54HC244F3A
CD54HC244F3A.A	Active	Production	CDIP (J) 20	20 TUBE	No	SNPB	N/A for Pkg Type	-55 to 125	8409601RA CD54HC244F3A
CD54HCT240F3A	Active	Production	CDIP (J) 20	20 TUBE	No	SNPB	N/A for Pkg Type	-55 to 125	8550501RA CD54HCT240F3A
CD54HCT240F3A.A	Active	Production	CDIP (J) 20	20 TUBE	No	SNPB	N/A for Pkg Type	-55 to 125	8550501RA CD54HCT240F3A
CD54HCT241F3A	Active	Production	CDIP (J) 20	20 TUBE	No	SNPB	N/A for Pkg Type	-55 to 125	CD54HCT241F3A
CD54HCT241F3A.A	Active	Production	CDIP (J) 20	20 TUBE	No	SNPB	N/A for Pkg Type	-55 to 125	CD54HCT241F3A
CD54HCT244F	Active	Production	CDIP (J) 20	20 TUBE	No	SNPB	N/A for Pkg Type	-55 to 125	CD54HCT244F
CD54HCT244F.A	Active	Production	CDIP (J) 20	20 TUBE	No	SNPB	N/A for Pkg Type	-55 to 125	CD54HCT244F
CD54HCT244F3A	Active	Production	CDIP (J) 20	20 TUBE	No	SNPB	N/A for Pkg Type	-55 to 125	8513001RA CD54HCT244F3A
CD54HCT244F3A.A	Active	Production	CDIP (J) 20	20 TUBE	No	SNPB	N/A for Pkg Type	-55 to 125	8513001RA CD54HCT244F3A
CD74HC240E	Active	Production	PDIP (N) 20	20 TUBE	Yes	NIPDAU	N/A for Pkg Type	-55 to 125	CD74HC240E
CD74HC240E.A	Active	Production	PDIP (N) 20	20 TUBE	Yes	NIPDAU	N/A for Pkg Type	-55 to 125	CD74HC240E
CD74HC240M	Obsolete	Production	SOIC (DW) 20	-	-	Call TI	Call TI	-55 to 125	HC240M
CD74HC240M96	Active	Production	SOIC (DW) 20	2000 LARGE T&R	Yes	NIPDAU	Level-1-260C-UNLIM	-55 to 125	HC240M
CD74HC240M96.A	Active	Production	SOIC (DW) 20	2000 LARGE T&R	Yes	NIPDAU	Level-1-260C-UNLIM	-55 to 125	HC240M
CD74HC241E	Active	Production	PDIP (N) 20	20 TUBE	Yes	NIPDAU	N/A for Pkg Type	-55 to 125	CD74HC241E
CD74HC241E.A	Active	Production	PDIP (N) 20	20 TUBE	Yes	NIPDAU	N/A for Pkg Type	-55 to 125	CD74HC241E
CD74HC241M	Obsolete	Production	SOIC (DW) 20	-	-	Call TI	Call TI	-55 to 125	HC241M
CD74HC241M96	Active	Production	SOIC (DW) 20	2000 LARGE T&R	Yes	NIPDAU	Level-1-260C-UNLIM	-55 to 125	HC241M

Orderable part number	Status (1)	Material type (2)	Package Pins	Package qty Carrier	RoHS (3)	Lead finish/ Ball material (4)	MSL rating/ Peak reflow (5)	Op temp (°C)	Part marking (6)
CD74HC241M96.A	Active	Production	SOIC (DW) 20	2000 LARGE T&R	Yes	NIPDAU	Level-1-260C-UNLIM	-55 to 125	HC241M
CD74HC244E	Active	Production	PDIP (N) 20	20 TUBE	Yes	NIPDAU	N/A for Pkg Type	-55 to 125	CD74HC244E
CD74HC244E.A	Active	Production	PDIP (N) 20	20 TUBE	Yes	NIPDAU	N/A for Pkg Type	-55 to 125	CD74HC244E
CD74HC244EE4	Active	Production	PDIP (N) 20	20 TUBE	Yes	NIPDAU	N/A for Pkg Type	-55 to 125	CD74HC244E
CD74HC244M	Obsolete	Production	SOIC (DW) 20	-	-	Call TI	Call TI	-55 to 125	HC244M
CD74HC244M96	Active	Production	SOIC (DW) 20	2000 LARGE T&R	Yes	NIPDAU	Level-1-260C-UNLIM	-55 to 125	HC244M
CD74HC244M96.A	Active	Production	SOIC (DW) 20	2000 LARGE T&R	Yes	NIPDAU	Level-1-260C-UNLIM	-55 to 125	HC244M
CD74HC244M96E4	Active	Production	SOIC (DW) 20	2000 LARGE T&R	Yes	NIPDAU	Level-1-260C-UNLIM	-55 to 125	HC244M
CD74HC244M96G4	Active	Production	SOIC (DW) 20	2000 LARGE T&R	Yes	NIPDAU	Level-1-260C-UNLIM	-55 to 125	HC244M
CD74HCT240E	Active	Production	PDIP (N) 20	20 TUBE	Yes	NIPDAU	N/A for Pkg Type	-55 to 125	CD74HCT240E
CD74HCT240E.A	Active	Production	PDIP (N) 20	20 TUBE	Yes	NIPDAU	N/A for Pkg Type	-55 to 125	CD74HCT240E
CD74HCT240EE4	Active	Production	PDIP (N) 20	20 TUBE	Yes	NIPDAU	N/A for Pkg Type	-55 to 125	CD74HCT240E
CD74HCT240M	Obsolete	Production	SOIC (DW) 20	-	-	Call TI	Call TI	-55 to 125	HCT240M
CD74HCT240M96	Active	Production	SOIC (DW) 20	2000 LARGE T&R	Yes	NIPDAU	Level-1-260C-UNLIM	-55 to 125	HCT240M
CD74HCT240M96.A	Active	Production	SOIC (DW) 20	2000 LARGE T&R	Yes	NIPDAU	Level-1-260C-UNLIM	-55 to 125	HCT240M
CD74HCT240PW	Obsolete	Production	TSSOP (PW) 20	-	-	Call TI	Call TI	-55 to 125	HK240
CD74HCT240PWR	Active	Production	TSSOP (PW) 20	2000 LARGE T&R	Yes	NIPDAU	Level-1-260C-UNLIM	-55 to 125	HK240
CD74HCT240PWR.A	Active	Production	TSSOP (PW) 20	2000 LARGE T&R	Yes	NIPDAU	Level-1-260C-UNLIM	-55 to 125	HK240
CD74HCT240PWT	Obsolete	Production	TSSOP (PW) 20	-	-	Call TI	Call TI	-55 to 125	HK240
CD74HCT241E	Active	Production	PDIP (N) 20	20 TUBE	Yes	NIPDAU	N/A for Pkg Type	-55 to 125	CD74HCT241E
CD74HCT241E.A	Active	Production	PDIP (N) 20	20 TUBE	Yes	NIPDAU	N/A for Pkg Type	-55 to 125	CD74HCT241E
CD74HCT241M96	Active	Production	SOIC (DW) 20	2000 LARGE T&R	Yes	NIPDAU	Level-1-260C-UNLIM	-55 to 125	HCT241M
CD74HCT241M96.A	Active	Production	SOIC (DW) 20	2000 LARGE T&R	Yes	NIPDAU	Level-1-260C-UNLIM	-55 to 125	HCT241M
CD74HCT244E	Active	Production	PDIP (N) 20	20 TUBE	Yes	NIPDAU	N/A for Pkg Type	-55 to 125	CD74HCT244E
CD74HCT244E.A	Active	Production	PDIP (N) 20	20 TUBE	Yes	NIPDAU	N/A for Pkg Type	-55 to 125	CD74HCT244E
CD74HCT244M	Obsolete	Production	SOIC (DW) 20	-	-	Call TI	Call TI	-55 to 125	HCT244M
CD74HCT244M96	Active	Production	SOIC (DW) 20	2000 LARGE T&R	Yes	NIPDAU	Level-1-260C-UNLIM	-55 to 125	HCT244M
CD74HCT244M96.A	Active	Production	SOIC (DW) 20	2000 LARGE T&R	Yes	NIPDAU	Level-1-260C-UNLIM	-55 to 125	HCT244M

(1) **Status:** For more details on status, see our [product life cycle](#).

(2) **Material type:** When designated, preproduction parts are prototypes/experimental devices, and are not yet approved or released for full production. Testing and final process, including without limitation quality assurance, reliability performance testing, and/or process qualification, may not yet be complete, and this item is subject to further changes or possible discontinuation. If available for ordering, purchases will be subject to an additional waiver at checkout, and are intended for early internal evaluation purposes only. These items are sold without warranties of any kind.

(3) **RoHS values:** Yes, No, RoHS Exempt. See the [TI RoHS Statement](#) for additional information and value definition.

(4) **Lead finish/Ball material:** Parts may have multiple material finish options. Finish options are separated by a vertical ruled line. Lead finish/Ball material values may wrap to two lines if the finish value exceeds the maximum column width.

(5) **MSL rating/Peak reflow:** The moisture sensitivity level ratings and peak solder (reflow) temperatures. In the event that a part has multiple moisture sensitivity ratings, only the lowest level per JEDEC standards is shown. Refer to the shipping label for the actual reflow temperature that will be used to mount the part to the printed circuit board.

(6) **Part marking:** There may be an additional marking, which relates to the logo, the lot trace code information, or the environmental category of the part.

Multiple part markings will be inside parentheses. Only one part marking contained in parentheses and separated by a "~" will appear on a part. If a line is indented then it is a continuation of the previous line and the two combined represent the entire part marking for that device.

Important Information and Disclaimer: The information provided on this page represents TI's knowledge and belief as of the date that it is provided. TI bases its knowledge and belief on information provided by third parties, and makes no representation or warranty as to the accuracy of such information. Efforts are underway to better integrate information from third parties. TI has taken and continues to take reasonable steps to provide representative and accurate information but may not have conducted destructive testing or chemical analysis on incoming materials and chemicals. TI and TI suppliers consider certain information to be proprietary, and thus CAS numbers and other limited information may not be available for release.

In no event shall TI's liability arising out of such information exceed the total purchase price of the TI part(s) at issue in this document sold by TI to Customer on an annual basis.

OTHER QUALIFIED VERSIONS OF CD54HC240, CD54HC244, CD54HCT240, CD54HCT241, CD54HCT244, CD74HC240, CD74HC244, CD74HCT240, CD74HCT241, CD74HCT244 :

● Catalog : [CD74HC240](#), [CD74HC244](#), [CD74HCT240](#), [CD74HCT241](#), [CD74HCT244](#)

● Military : [CD54HC240](#), [CD54HC244](#), [CD54HCT240](#), [CD54HCT241](#), [CD54HCT244](#)

NOTE: Qualified Version Definitions:

- Catalog - TI's standard catalog product
- Military - QML certified for Military and Defense Applications

TAPE AND REEL INFORMATION

QUADRANT ASSIGNMENTS FOR PIN 1 ORIENTATION IN TAPE

*All dimensions are nominal

Device	Package Type	Package Drawing	Pins	SPQ	Reel Diameter (mm)	Reel Width W1 (mm)	A0 (mm)	B0 (mm)	K0 (mm)	P1 (mm)	W (mm)	Pin1 Quadrant
CD74HC240M96	SOIC	DW	20	2000	330.0	24.4	10.8	13.3	2.7	12.0	24.0	Q1
CD74HC241M96	SOIC	DW	20	2000	330.0	24.4	10.8	13.3	2.7	12.0	24.0	Q1
CD74HC244M96	SOIC	DW	20	2000	330.0	24.4	10.8	13.3	2.7	12.0	24.0	Q1
CD74HCT240M96	SOIC	DW	20	2000	330.0	24.4	10.8	13.3	2.7	12.0	24.0	Q1
CD74HCT240PWR	TSSOP	PW	20	2000	330.0	16.4	6.95	7.0	1.4	8.0	16.0	Q1
CD74HCT241M96	SOIC	DW	20	2000	330.0	24.4	10.8	13.3	2.7	12.0	24.0	Q1
CD74HCT241M96	SOIC	DW	20	2000	330.0	24.4	10.9	13.3	2.7	12.0	24.0	Q1
CD74HCT244M96	SOIC	DW	20	2000	330.0	24.4	10.8	13.3	2.7	12.0	24.0	Q1
CD74HCT244M96	SOIC	DW	20	2000	330.0	24.4	10.9	13.3	2.7	12.0	24.0	Q1

TAPE AND REEL BOX DIMENSIONS

*All dimensions are nominal

Device	Package Type	Package Drawing	Pins	SPQ	Length (mm)	Width (mm)	Height (mm)
CD74HC240M96	SOIC	DW	20	2000	356.0	356.0	45.0
CD74HC241M96	SOIC	DW	20	2000	356.0	356.0	45.0
CD74HC244M96	SOIC	DW	20	2000	356.0	356.0	45.0
CD74HCT240M96	SOIC	DW	20	2000	356.0	356.0	45.0
CD74HCT240PWR	TSSOP	PW	20	2000	353.0	353.0	32.0
CD74HCT241M96	SOIC	DW	20	2000	356.0	356.0	45.0
CD74HCT241M96	SOIC	DW	20	2000	356.0	356.0	45.0
CD74HCT244M96	SOIC	DW	20	2000	356.0	356.0	45.0
CD74HCT244M96	SOIC	DW	20	2000	356.0	356.0	45.0

TUBE

*All dimensions are nominal

Device	Package Name	Package Type	Pins	SPQ	L (mm)	W (mm)	T (μm)	B (mm)
CD74HC240E	N	PDIP	20	20	506	13.97	11230	4.32
CD74HC240E.A	N	PDIP	20	20	506	13.97	11230	4.32
CD74HC241E	N	PDIP	20	20	506	13.97	11230	4.32
CD74HC241E.A	N	PDIP	20	20	506	13.97	11230	4.32
CD74HC244E	N	PDIP	20	20	506	13.97	11230	4.32
CD74HC244E.A	N	PDIP	20	20	506	13.97	11230	4.32
CD74HC244EE4	N	PDIP	20	20	506	13.97	11230	4.32
CD74HCT240E	N	PDIP	20	20	506	13.97	11230	4.32
CD74HCT240E.A	N	PDIP	20	20	506	13.97	11230	4.32
CD74HCT240EE4	N	PDIP	20	20	506	13.97	11230	4.32
CD74HCT241E	N	PDIP	20	20	506	13.97	11230	4.32
CD74HCT241E.A	N	PDIP	20	20	506	13.97	11230	4.32
CD74HCT244E	N	PDIP	20	20	506	13.97	11230	4.32
CD74HCT244E.A	N	PDIP	20	20	506	13.97	11230	4.32

PW0020A



PACKAGE OUTLINE

TSSOP - 1.2 mm max height

SMALL OUTLINE PACKAGE



4220206/A 02/2017

NOTES:

- All linear dimensions are in millimeters. Any dimensions in parenthesis are for reference only. Dimensioning and tolerancing per ASME Y14.5M.
- This drawing is subject to change without notice.
- This dimension does not include mold flash, protrusions, or gate burrs. Mold flash, protrusions, or gate burrs shall not exceed 0.15 mm per side.
- This dimension does not include interlead flash. Interlead flash shall not exceed 0.25 mm per side.
- Reference JEDEC registration MO-153.

EXAMPLE BOARD LAYOUT

PW0020A

TSSOP - 1.2 mm max height

SMALL OUTLINE PACKAGE



LAND PATTERN EXAMPLE
EXPOSED METAL SHOWN
SCALE: 10X



4220206/A 02/2017

NOTES: (continued)

- 6. Publication IPC-7351 may have alternate designs.
- 7. Solder mask tolerances between and around signal pads can vary based on board fabrication site.

EXAMPLE STENCIL DESIGN

PW0020A

TSSOP - 1.2 mm max height

SMALL OUTLINE PACKAGE



SOLDER PASTE EXAMPLE
BASED ON 0.125 mm THICK STENCIL
SCALE: 10X

4220206/A 02/2017

NOTES: (continued)

8. Laser cutting apertures with trapezoidal walls and rounded corners may offer better paste release. IPC-7525 may have alternate design recommendations.
9. Board assembly site may have different recommendations for stencil design.

J (R-GDIP-T**)

14 LEADS SHOWN

CERAMIC DUAL IN-LINE PACKAGE



DIM \ PINS **	14	16	18	20
A	0.300 (7,62) BSC	0.300 (7,62) BSC	0.300 (7,62) BSC	0.300 (7,62) BSC
B MAX	0.785 (19,94)	.840 (21,34)	0.960 (24,38)	1.060 (26,92)
B MIN	—	—	—	—
C MAX	0.300 (7,62)	0.300 (7,62)	0.310 (7,87)	0.300 (7,62)
C MIN	0.245 (6,22)	0.245 (6,22)	0.220 (5,59)	0.245 (6,22)



4040083/F 03/03

- NOTES:
- All linear dimensions are in inches (millimeters).
 - This drawing is subject to change without notice.
 - This package is hermetically sealed with a ceramic lid using glass frit.
 - Index point is provided on cap for terminal identification only on press ceramic glass frit seal only.
 - Falls within MIL STD 1835 GDIP1-T14, GDIP1-T16, GDIP1-T18 and GDIP1-T20.

N (R-PDIP-T**)

PLASTIC DUAL-IN-LINE PACKAGE

16 PINS SHOWN



- NOTES:
- A. All linear dimensions are in inches (millimeters).
 - B. This drawing is subject to change without notice.
 - $\triangle C$ Falls within JEDEC MS-001, except 18 and 20 pin minimum body length (Dim A).
 - $\triangle D$ The 20 pin end lead shoulder width is a vendor option, either half or full width.

4040049/E 12/2002

DW0020A



PACKAGE OUTLINE

SOIC - 2.65 mm max height

SOIC



4220724/A 05/2016

NOTES:

1. All linear dimensions are in millimeters. Dimensions in parenthesis are for reference only. Dimensioning and tolerancing per ASME Y14.5M.
2. This drawing is subject to change without notice.
3. This dimension does not include mold flash, protrusions, or gate burrs. Mold flash, protrusions, or gate burrs shall not exceed 0.15 mm per side.
4. This dimension does not include interlead flash. Interlead flash shall not exceed 0.43 mm per side.
5. Reference JEDEC registration MS-013.

EXAMPLE BOARD LAYOUT

DW0020A

SOIC - 2.65 mm max height

SOIC



LAND PATTERN EXAMPLE
SCALE:6X



SOLDER MASK DETAILS

4220724/A 05/2016

NOTES: (continued)

- 6. Publication IPC-7351 may have alternate designs.
- 7. Solder mask tolerances between and around signal pads can vary based on board fabrication site.

EXAMPLE STENCIL DESIGN

DW0020A

SOIC - 2.65 mm max height

SOIC



SOLDER PASTE EXAMPLE
BASED ON 0.125 mm THICK STENCIL
SCALE:6X

4220724/A 05/2016

NOTES: (continued)

8. Laser cutting apertures with trapezoidal walls and rounded corners may offer better paste release. IPC-7525 may have alternate design recommendations.
9. Board assembly site may have different recommendations for stencil design.

IMPORTANT NOTICE AND DISCLAIMER

TI PROVIDES TECHNICAL AND RELIABILITY DATA (INCLUDING DATASHEETS), DESIGN RESOURCES (INCLUDING REFERENCE DESIGNS), APPLICATION OR OTHER DESIGN ADVICE, WEB TOOLS, SAFETY INFORMATION, AND OTHER RESOURCES "AS IS" AND WITH ALL FAULTS, AND DISCLAIMS ALL WARRANTIES, EXPRESS AND IMPLIED, INCLUDING WITHOUT LIMITATION ANY IMPLIED WARRANTIES OF MERCHANTABILITY, FITNESS FOR A PARTICULAR PURPOSE OR NON-INFRINGEMENT OF THIRD PARTY INTELLECTUAL PROPERTY RIGHTS.

These resources are intended for skilled developers designing with TI products. You are solely responsible for (1) selecting the appropriate TI products for your application, (2) designing, validating and testing your application, and (3) ensuring your application meets applicable standards, and any other safety, security, regulatory or other requirements.

These resources are subject to change without notice. TI grants you permission to use these resources only for development of an application that uses the TI products described in the resource. Other reproduction and display of these resources is prohibited. No license is granted to any other TI intellectual property right or to any third party intellectual property right. TI disclaims responsibility for, and you fully indemnify TI and its representatives against any claims, damages, costs, losses, and liabilities arising out of your use of these resources.

TI's products are provided subject to [TI's Terms of Sale](#), [TI's General Quality Guidelines](#), or other applicable terms available either on [ti.com](#) or provided in conjunction with such TI products. TI's provision of these resources does not expand or otherwise alter TI's applicable warranties or warranty disclaimers for TI products. Unless TI explicitly designates a product as custom or customer-specified, TI products are standard, catalog, general purpose devices.

TI objects to and rejects any additional or different terms you may propose.

Copyright © 2026, Texas Instruments Incorporated

Last updated 10/2025