

- Two 32-Bit, 66-MHz PCI Buses
- Configurable for PCI Power Management Interface Specification
- Provides CompactPCI™ Hot-Swap Functionality
- 3.3-V Core Logic With Universal PCI Interfaces Compatible With 3.3-V and 5-V PCI Signaling Environments
- Provides Internal Two-Tier Arbitration for up to Nine Secondary Bus Masters and Supports an External Secondary Bus Arbiter
- Burst Data Transfers With Pipeline Architecture to Maximize Data Throughput in Both Directions
- Independent Read and Write Buffers for Each Direction
- Up to Three Delayed Transactions in Both Directions
- Provides 10 Secondary PCI Clock Outputs
- Predictable Latency per PCI Local Bus Specification
- Propagates Bus Locking
- Supports Write Combining for Enhanced Data Throughput
- Supports Frame-to-Frame Delay of Only Four PCI Clocks From One Bus to Another
- Secondary Bus is Driven Low During Reset
- Provides VGA/Palette Memory and I/O, and Subtractive Decoding Options
- Advanced Submicron, Low-Power CMOS Technology
- Packaged in 208-Terminal QFP

description

This data sheet for PCI2050A lists only enhancements to PCI2050 and must be used in conjunction with PCI2050, PCI-to-PCI bridge, data manual (Literature number SCPS053A)

The Texas Instruments PCI2050A PCI-to-PCI bridge provides a high performance connection path between two peripheral component interconnect (PCI) buses operating at a maximum bus frequency of 66-MHz. Transactions occur between masters on one and targets on another PCI bus, and the PCI2050A allows bridged transactions to occur concurrently on both buses. The bridge supports burst mode transfers to maximize data throughput, and the two bus traffic paths through the bridge act independently.

The PCI2050A bridge is compliant with the PCI local bus specification, and can be used to overcome the electrical loading limits of 10 devices per PCI bus and one PCI device per extension slot by creating hierarchical buses. The PCI2050A provides two-tier internal arbitration for up to nine secondary bus masters and may be implemented with an external bus arbiter.

The CompactPCI hot-swap extended PCI capability makes the PCI2050A an ideal solution for multifunction compact PCI cards and adapting single function cards to hot-swap compliance.

The PCI2050A bridge is compliant with PCI-to-PCI bridge specification 1.1. The PCI2050A provides compliance for PCI Power Management 1.0 and 1.1. The PCI2050A has been designed to lead the industry in power consumption and data throughput. An advanced CMOS process achieves low system power consumption while operating at PCI clock rates up to 66-MHz.



Please be aware that an important notice concerning availability, standard warranty, and use in critical applications of Texas Instruments semiconductor products and disclaimers thereto appears at the end of this data sheet.

CompactPCI is a trademark of PICMG-PCI Industrial Computer Manufacturers Group, Inc.
All other trademarks are the property of their respective owners.

PRODUCTION DATA information is current as of publication date. Products conform to specifications per the terms of Texas Instruments standard warranty. Production processing does not necessarily include testing of all parameters.



POST OFFICE BOX 655303 • DALLAS, TEXAS 75265

Copyright © 2001, Texas Instruments Incorporated

PCI2050A PCI-to-PCI BRIDGE

SCPS067 – MAY 2001

PDV LOW-PROFILE QUAD FLAT PACKAGE TOP VIEW

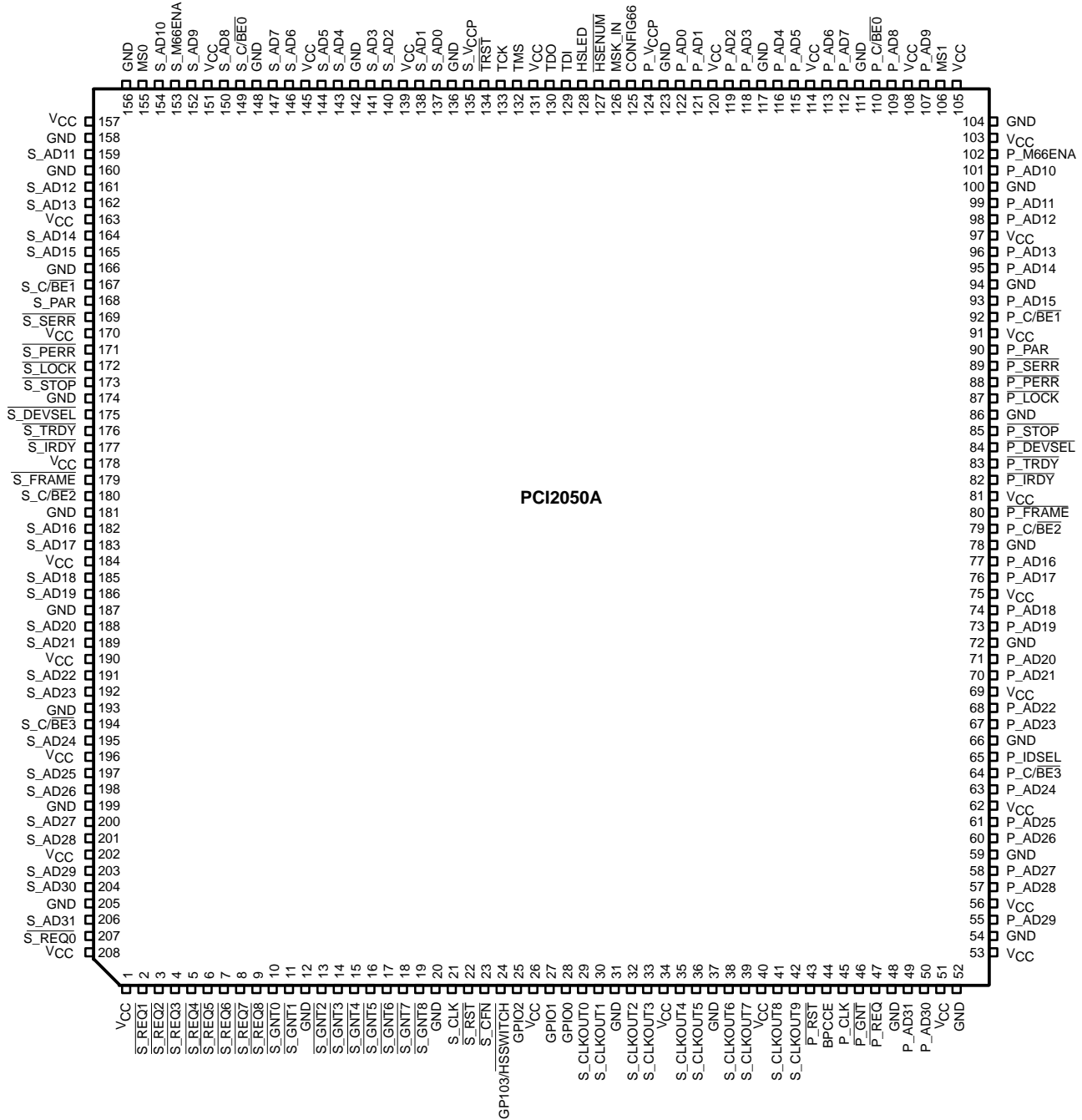

POST OFFICE BOX 655303 • DALLAS, TEXAS 75265

Terminal Functions

primary PCI system terminals

TERMINAL		I/O	DESCRIPTION
NAME	NO.		
P_CLK	45	I	Primary PCI bus clock. P_CLK provides timing for all transactions on the primary PCI bus. All primary PCI signals are sampled at rising edge of P_CLK.
$\overline{\text{P_RST}}$	43	I	PCI reset. When the primary PCI bus reset is asserted, $\overline{\text{P_RST}}$ causes the bridge to put all output buffers in a high-impedance state and reset all internal registers. When asserted, the device is completely nonfunctional. During $\overline{\text{P_RST}}$, the secondary interface is driven low. After $\overline{\text{P_RST}}$ is deasserted, the bridge is in its default state.

primary PCI address and data terminals

TERMINAL		I/O	DESCRIPTION
NAME	NO.		
P_AD31	49	I/O	Primary address/data bus. These signals make up the multiplexed PCI address and data bus on the primary interface. During the address phase of a primary bus PCI cycle, P_AD31–P_AD0 contain a 32-bit address or other destination information. During the data phase, P_AD31–P_AD0 contain data.
P_AD30	50		
P_AD29	55		
P_AD28	57		
P_AD27	58		
P_AD26	60		
P_AD25	61		
P_AD24	63		
P_AD23	67		
P_AD22	68		
P_AD21	70		
P_AD20	71		
P_AD19	73		
P_AD18	74		
P_AD17	76		
P_AD16	77		
P_AD15	93		
P_AD14	95		
P_AD13	96		
P_AD12	98		
P_AD11	99		
P_AD10	101		
P_AD9	107		
P_AD8	109		
P_AD7	112		
P_AD6	113		
P_AD5	115		
P_AD4	116		
P_AD3	118		
P_AD2	119		
P_AD1	121		
P_AD0	122		
$\overline{\text{P_C/BE3}}$	64	I/O	Primary bus commands and byte enables. These signals are multiplexed on the same PCI terminals. During the address phase of a primary bus PCI cycle, $\overline{\text{P_C/BE3}}$ – $\overline{\text{P_C/BE0}}$ define the bus command. During the data phase, this 4-bit bus is used as byte enables. The byte enables determine which byte paths of the full 32-bit data bus carry meaningful data. $\overline{\text{P_C/BE0}}$ applies to byte 0 (P_AD7–P_AD0), $\overline{\text{P_C/BE1}}$ applies to byte 1 (P_AD15–P_AD8), $\overline{\text{P_C/BE2}}$ applies to byte 2 (P_AD23–P_AD16), and $\overline{\text{P_C/BE3}}$ applies to byte 3 (P_AD31–P_AD24).
$\overline{\text{P_C/BE2}}$	79		
$\overline{\text{P_C/BE1}}$	92		
$\overline{\text{P_C/BE0}}$	110		

Terminal Functions (Continued)

primary PCI interface control terminals

TERMINAL		I/O	DESCRIPTION
NAME	NO.		
$\overline{P_DEVSEL}$	84	I/O	Primary device select. The bridge asserts $\overline{P_DEVSEL}$ to claim a PCI cycle as the target device. As a PCI master on the primary bus, the bridge monitors $\overline{P_DEVSEL}$ until a target responds. If no target responds before time-out occurs, then the bridge terminates the cycle with a master abort.
$\overline{P_FRAME}$	80	I/O	Primary cycle frame. $\overline{P_FRAME}$ is driven by the master of a primary bus cycle. $\overline{P_FRAME}$ is asserted to indicate that a bus transaction is beginning, and data transfers continue while this signal is asserted. When $\overline{P_FRAME}$ is deasserted, the primary bus transaction is in the final data phase.
$\overline{P_GNT}$	46	I	Primary bus grant to bridge. $\overline{P_GNT}$ is driven by the primary PCI bus arbiter to grant the bridge access to the primary PCI bus after the current data transaction has completed. $\overline{P_GNT}$ may or may not follow a primary bus request, depending on the primary bus arbitration algorithm.
P_IDSEL	65	I	Primary initialization device select. P_IDSEL selects the bridge during configuration space accesses. P_IDSEL can be connected to one of the upper 24 PCI address lines on the primary PCI bus. Note: There is no IDSEL signal interfacing the secondary PCI bus; thus, the entire configuration space of the bridge can only be accessed from the primary bus.
$\overline{P_IRDY}$	82	I/O	Primary initiator ready. $\overline{P_IRDY}$ indicates ability of the primary bus master to complete the current data phase of the transaction. A data phase is completed on a rising edge of P_CLK where both $\overline{P_IRDY}$ and $\overline{P_TRDY}$ are asserted. Until $\overline{P_IRDY}$ and $\overline{P_TRDY}$ are both sampled asserted, wait states are inserted.
$\overline{P_LOCK}$	87	I/O	Primary PCI bus lock. $\overline{P_LOCK}$ is used to lock the primary bus and gain exclusive access as a bus master.
P_PAR	90	I/O	Primary parity. In all primary bus read and write cycles, the bridge calculates even parity across the P_AD and P_C/BE buses. As a bus master during PCI write cycles, the bridge outputs this parity indicator with a one-P_CLK delay. As a target during PCI read cycles, the calculated parity is compared to the parity indicator of the master; a miscompare can result in a parity error assertion ($\overline{P_PERR}$).
$\overline{P_PERR}$	88	I/O	Primary parity error indicator. $\overline{P_PERR}$ is driven by a primary bus PCI device to indicate that calculated parity does not match P_PAR when $\overline{P_PERR}$ is enabled through bit 6 of the command register (PCI offset 04h).
$\overline{P_REQ}$	47	O	Primary PCI bus request. Asserted by the bridge to request access to the primary PCI bus as a master.
$\overline{P_SERR}$	89	O	Primary system error. Output pulsed from the bridge when enabled through the command register (PCI offset 04h), indicating a system error has occurred. The bridge needs not be the target of the primary PCI cycle to assert this signal. When bit 6 is enabled in the bridge control register (PCI offset 3Eh), this signal also pulses, indicating that a system error has occurred on one of the subordinate buses downstream from the bridge.
$\overline{P_STOP}$	85	I/O	Primary cycle stop signal. This signal is driven by a PCI target to request that the master stop the current primary bus transaction. This signal is used for target disconnects and is commonly asserted by target devices which do not support burst data transfers.
$\overline{P_TRDY}$	83	I/O	Primary target ready. $\overline{P_TRDY}$ indicates the ability of the primary bus target to complete the current data phase of the transaction. A data phase is completed upon a rising edge of P_CLK where both $\overline{P_IRDY}$ and $\overline{P_TRDY}$ are asserted. Until both $\overline{P_IRDY}$ and $\overline{P_TRDY}$ are asserted, wait states are inserted.

Terminal Functions (Continued)

secondary PCI system terminals

TERMINAL		I/O	DESCRIPTION
NAME	NO.		
S_CLKOUT9	42	O	Secondary PCI bus clocks. Provide timing for all transactions on the secondary PCI bus. Each secondary bus device samples all secondary PCI signals at the rising edge of its corresponding S_CLKOUT input.
S_CLKOUT8	41		
S_CLKOUT7	39		
S_CLKOUT6	38		
S_CLKOUT5	36		
S_CLKOUT4	35		
S_CLKOUT3	33		
S_CLKOUT2	32		
S_CLKOUT1	30		
S_CLKOUT0	29		
S_CLK	21	I	Secondary PCI bus clock input. This input synchronizes the PCI2050 to the secondary bus clocks.
$\overline{\text{S_CFN}}$	23	I	Secondary external arbiter enable. When this signal is high, the secondary external arbiter is enabled. When the external arbiter is enabled, the PCI2050 $\overline{\text{S_REQ0}}$ terminal is reconfigured as a secondary bus grant input to the bridge and $\overline{\text{S_GNT0}}$ is reconfigured as a secondary bus master request to the external arbiter on the secondary bus.
$\overline{\text{S_RST}}$	22	O	Secondary PCI reset. $\overline{\text{S_RST}}$ is a logical OR of $\overline{\text{P_RST}}$ and the state of the secondary bus reset bit (bit 6) of the bridge control register (PCI offset 3Eh). $\overline{\text{S_RST}}$ is asynchronous with respect to the state of the secondary interface CLK signal.

PCI2050A PCI-to-PCI BRIDGE

SCPS067 – MAY 2001

Terminal Functions (Continued)

secondary PCI address and data terminals

TERMINAL		I/O	DESCRIPTION
NAME	NO.		
S_AD31	206	I/O	Secondary address/data bus. These signals make up the multiplexed PCI address and data bus on the secondary interface. During the address phase of a secondary bus PCI cycle, S_AD31–S_AD0 contain a 32-bit address or other destination information. During the data phase, S_AD31–S_AD0 contain data.
S_AD30	204		
S_AD29	203		
S_AD28	201		
S_AD27	200		
S_AD26	198		
S_AD25	197		
S_AD24	195		
S_AD23	192		
S_AD22	191		
S_AD21	189		
S_AD20	188		
S_AD19	186		
S_AD18	185		
S_AD17	183		
S_AD16	182		
S_AD15	165		
S_AD14	164		
S_AD13	162		
S_AD12	161		
S_AD11	159		
S_AD10	154		
S_AD9	152		
S_AD8	150		
S_AD7	147		
S_AD6	146		
S_AD5	144		
S_AD4	143		
S_AD3	141		
S_AD2	140		
S_AD1	138		
S_AD0	137		
S_C/BE3 S_C/BE2 S_C/BE1 S_C/BE0	194 180 167 149	I/O	Secondary bus commands and byte enables. These signals are multiplexed on the same PCI terminals. During the address phase of a secondary bus PCI cycle, S_C/BE3–S_C/BE0 define the bus command. During the data phase, this 4-bit bus is used as byte enables. The byte enables determine which byte paths of the full 32-bit data bus carry meaningful data. S_C/BE0 applies to byte 0 (S_AD7–S_AD0), S_C/BE1 applies to byte 1 (S_AD15–S_AD8), S_C/BE2 applies to byte 2 (S_AD23–S_AD16), and S_C/BE3 applies to byte 3 (S_AD31–S_AD24).
S_DEVSEL	175	I/O	Secondary device select. The bridge asserts S_DEVSEL to claim a PCI cycle as the target device. As a PCI master on the secondary bus, the bridge monitors S_DEVSEL until a target responds. If no target responds before time-out occurs, then the bridge terminates the cycle with a master abort.
S_FRAME	179	I/O	Secondary cycle frame. S_FRAME is driven by the master of a secondary bus cycle. S_FRAME is asserted to indicate that a bus transaction is beginning and data transfers continue while S_FRAME is asserted. When S_FRAME is deasserted, the secondary bus transaction is in the final data phase.
S_GNT8 S_GNT7 S_GNT6 S_GNT5 S_GNT4 S_GNT3 S_GNT2 S_GNT1 S_GNT0	19 18 17 16 15 14 13 11 10	O	Secondary bus grant to the bridge. The bridge provides internal arbitration and these signals are used to grant potential secondary PCI bus masters access to the bus. Ten potential masters (including the bridge) can be located on the secondary PCI bus. When the internal arbiter is disabled, S_GNT0 is reconfigured as an external secondary bus request signal for the bridge.



Terminal Functions (Continued)

secondary PCI interface control terminals

TERMINAL		I/O	DESCRIPTION
NAME	NO.		
$\overline{S_IRDY}$	177	I/O	Secondary initiator ready. $\overline{S_IRDY}$ indicates the ability of the secondary bus master to complete the current data phase of the transaction. A data phase is completed on a rising edge of S_CLK where both $\overline{S_IRDY}$ and $\overline{S_TRDY}$ are asserted; until $\overline{S_IRDY}$ and $\overline{S_TRDY}$ are asserted, wait states are inserted.
$\overline{S_LOCK}$	172	I/O	Secondary PCI bus lock. $\overline{S_LOCK}$ is used to lock the secondary bus and gain exclusive access as a master.
S_PAR	168	I/O	Secondary parity. In all secondary bus read and write cycles, the bridge calculates even parity across the S_AD and S_C/BE buses. As a master during PCI write cycles, the bridge outputs this parity indicator with a one-S_CLK delay. As a target during PCI read cycles, the calculated parity is compared to the master parity indicator. A miscompare can result in a parity error assertion (S_PERR).
$\overline{S_PERR}$	171	I/O	Secondary parity error indicator. $\overline{S_PERR}$ is driven by a secondary bus PCI device to indicate that calculated parity does not match S_PAR when enabled through the command register (PCI offset 04h).
$\overline{S_REQ8}$ $\overline{S_REQ7}$ $\overline{S_REQ6}$ $\overline{S_REQ5}$ $\overline{S_REQ4}$ $\overline{S_REQ3}$ $\overline{S_REQ2}$ $\overline{S_REQ1}$ $\overline{S_REQ0}$	9 8 7 6 5 4 3 2 207	I	Secondary PCI bus request signals. The bridge provides internal arbitration, and these signals are used as inputs from secondary PCI bus masters requesting the bus. Ten potential masters (including the bridge) can be located on the secondary PCI bus. When the internal arbiter is disabled, the $\overline{S_REQ0}$ signal is reconfigured as an external secondary bus grant for the bridge.
$\overline{S_SERR}$	169	I	Secondary system error. $\overline{S_SERR}$ is passed through the primary interface by the bridge if enabled through the bridge control register (PCI offset 3Eh). $\overline{S_SERR}$ is never asserted by the bridge.
$\overline{S_STOP}$	173	I/O	Secondary cycle stop signal. $\overline{S_STOP}$ is driven by a PCI target to request that the master stop the current secondary bus transaction. $\overline{S_STOP}$ is used for target disconnects and is commonly asserted by target devices that do not support burst data transfers.
$\overline{S_TRDY}$	176	I/O	Secondary target ready. $\overline{S_TRDY}$ indicates the ability of the secondary bus target to complete the current data phase of the transaction. A data phase is completed on a rising edge of S_CLK where both $\overline{S_IRDY}$ and $\overline{S_TRDY}$ are asserted; until $\overline{S_IRDY}$ and $\overline{S_TRDY}$ are asserted, wait states are inserted.

Terminal Functions (Continued)

miscellaneous terminals

TERMINAL		I/O	DESCRIPTION
NAME	NO.		
BPCCE	44	I	Bus/power clock control management terminal. When signal BPCCE is tied high, and when the PCI2050 is placed in the D3 power state, it enables the PCI2050 to place the secondary bus in the B2 power state. The PCI2050 disables the secondary clocks and drives them to 0. When tied low, placing the PCI2050 in the D3 power state has no effect on the secondary bus clocks.
GPIO3/HSSWITCH GPIO2 GPIO1 GPIO0	24 25 27 28	I	General-purpose I/O terminals GPIO3 is HSSWITCH in cPCI mode. HSSWITCH provides the status of the ejector handle switch to the cPCI logic.
HSENUM	127	O	Hot-swap ENUM
HSLED	128	O	Hot-swap LED output
MS0	155	I	Mode select 0
MS1	106	I	Mode select 1
P_M66ENA	102	I	Primary interface 66 MHz enable. This input-only signal pin is used to designate the primary interface bus speed. This signal should be pulled low for 33 MHz operation on the primary bus. In this case S_M66ENA signal will be driven low by the PCI2050A, forcing the secondary bus to run at 33 MHz. For 66-MHz operation, this signal should be pulled high.
CONFIG66	125	I	Configure 66 MHz operation. This input-only pin is used to specify if PCI2050A is capable of running at 66 MHz. If this terminal is tied high, then device can be run at 66 MHz. If this pin is tied low, then PCI2050A can only function under the 33 MHz PCI specification.
S_M66ENA	153	I/O	Secondary 66-MHz enable terminal. This signal is used to designate the secondary bus speed. If the P_M66ENA is driven low, then this signal is driven low by the PCI2050A forcing secondary bus to run at 33 MHz. If the primary bus is running at 66 MHz (P_M66ENA is high), then S_M66ENA is an input and should be externally pulled high for the secondary bus to operate at 66 MHz or pulled low for secondary bus to operate at 33 MHz. Note that S_M66ENA is an open drained output.

JTAG interface terminals

TERMINAL		I/O	DESCRIPTION
NAME	NO.		
TCK	133	I	JTAG boundary-scan clock. TCK is the clock controlling the JTAG logic.
TDI	129	I	JTAG serial data in. TDI is the serial input through which JTAG instructions and test data enter the JTAG interface. The new data on TDI is sampled on the rising edge of TCK.
TDO	130	O	JTAG serial data out. TDO is the serial output through which test instructions and data from the test logic leave the PCI2050.
TMS	132	I	JTAG test mode select. TMS causes state transitions in the test access port controller.
$\overline{\text{TRST}}$	134	I	JTAG TAP reset. When $\overline{\text{TRST}}$ is asserted low, the TAP controller is asynchronously forced to enter a reset state and initialize the test logic.

Terminal Functions (Continued)

power supply terminals

TERMINAL		DESCRIPTION
NAME	NO.	
GND	12, 20, 31, 37, 48, 52, 54, 59, 66, 72, 78, 86, 94, 100, 104, 111, 117, 123, 136, 142, 148, 156, 158, 160, 166, 174, 181, 187, 193, 199, 205	Device ground terminals
V _{CC}	1, 26, 34, 40, 51, 53, 56, 62, 69, 75, 81, 91, 97, 103, 105, 108, 114, 120, 131, 139, 145, 151, 157, 163, 170, 178, 184, 190, 196, 202, 208	Power-supply terminal for core logic (3.3 V)
P_V _{CCP}	124	Primary bus-signaling environment supply. P_V _{CCP} is used in protection circuitry on primary bus I/O signals.
S_V _{CCP}	135	Secondary bus-signaling environment supply. S_V _{CCP} is used in protection circuitry on secondary bus I/O signals.

detailed description

The PCI2050 is a bridge between two PCI buses and is compliant with both the PCI local bus specification and the PCI-to-PCI bridge specification. The bridge supports two 32-bit PCI buses operating at a maximum of 66 MHz. The primary and secondary buses operate independently in either 3.3-V or 5-V signaling environment. The core logic of the bridge, however, is powered at 3.3 V to reduce power consumption.

Host software interacts with the bridge through internal registers. These registers provide the standard PCI status and control for both the primary and secondary buses. Many vendor-specific features that exist in the TI extension register set are included in the bridge. The PCI configuration header of the bridge is only accessible from the primary PCI interface.

The bridge provides internal arbitration for the nine possible bus masters, and provides each with a dedicated active low request/grant pair ($\overline{\text{REQ}}/\overline{\text{GNT}}$). The arbiter features a two-tier rotational scheme with the PCI2050A bridge defaulting to the highest priority tier. The PCI2050A also supports external arbitration.

Upon system power up, power-on self test (POST) software configures the bridge according to the devices that exist on subordinate buses, and enables performance-enhancing features of the PCI2050. In a typical system, this is the only communication with the bridge internal register set.

write combining

PCI2050A supports write combining for upstream and downstream transactions. This feature is used to combine separate sequential memory write transactions into a single burst transactions. This feature can only be used if the address of the next memory write transaction is the next sequential address after the address of the last double word of the previous memory transaction. For example if the current memory transaction ends at address X and next memory transaction starts at address X+1, then PCI2050A combines both transactions into a single transaction.

The write combining feature of PCI2050A is enabled by default on power on reset. It can also be disabled by setting bit 0 of the TI diagnostics register at offset F0h to 1.

PCI2050A

PCI-to-PCI BRIDGE

SCPS067 – MAY 2001

detailed description (continued)

66-MHz operation

PCI2050A supports two 32-bit PCI buses operating at a maximum frequency of 66-MHz. The 66-MHz clocking requires three terminals P_M66ENA, S_M66ENA and CONFIG66. To enable 66 MHz operation, the signal CONFIG66 must be tied high on the board. This sets the 66 MHz capable bit in the primary and secondary status register. The P_M66ENA and S_M66ENA must not be pulled high unless CONFIG66 is also high.

The signals P_M66ENA and S_M66ENA indicate whether the primary or secondary interfaces are working at 66 MHz. This information is needed to control the frequency of the secondary bus. Note that PCI local bus specification 2.2 restricts clock frequency changes above 33 MHz to during reset only.

The following frequency combinations are supported on the primary and secondary buses in PCI2050A:

- 66 MHz primary bus, 66 MHz secondary bus
- 66 MHz primary bus, 33 MHz secondary bus
- 33 MHz primary bus, 33 MHz secondary bus

The PCI2050A does not support 33-MHz primary/66-MHz secondary bus operation. If CONFIG66 is high and P_M66ENA is low, the PCI2050A pulls down S_M66ENA to indicate that secondary bus is running at 33 MHz.

The 2050A generates the clock signals S_CLKOUT[9:0] for the secondary bus devices and its own interface. It divides the P_CLK by two to generate the secondary clock outputs whenever the primary bus is running at 66 MHz and secondary bus is running at 33 MHz. The bridge detects this condition by polling P_M66ENA and S_M66ENA.



POST OFFICE BOX 655303 • DALLAS, TEXAS 75265

bridge configuration header

The bridge configuration header for PCI2050A is exactly the same as the bridge configuration header for PCI2050 except for the following registers.

The PCI2050A bridge is a single-function PCI device. The configuration header is in compliance with the *PCI-to-PCI Bridge Specification 1.1*. Table 1 shows the PCI configuration header, which includes the predefined portion of the bridge configuration space. The PCI configuration offset is shown in the right column under the OFFSET heading.

Table 1. Bridge Configuration Header

REGISTER NAME				OFFSET
Device ID		Vendor ID		00h
Status		Command		04h
Class code			Revision ID	08h
BIST	Header type	Primary latency timer	Cache line size	0Ch
Base address 0				10h
Base address 1				14h
Secondary bus latency timer	Subordinate bus number	Secondary bus number	Primary bus number	18h
Secondary status		I/O limit	I/O base	1Ch
Memory limit		Memory base		20h
Prefetchable memory limit		Prefetchable memory base		24h
Prefetchable base upper 32 bits				28h
Prefetchable limit upper 32 bits				2Ch
I/O limit upper 16 bits		I/O base upper 16 bits		30h
Reserved			Capability pointer	34h
Expansion ROM base address				38h
Bridge control		Interrupt pin	Interrupt line	3Ch
Arbiter control		Extended diagnostic	Chip control	40h
Reserved				44h–60h
GPIO input data	GPIO output enable	GPIO output data	P_SERR event disable	64h
Reserved	P_SERR status	Secondary clock control		68h
Reserved				6Ch–D8h
Power management capabilities		PM next item pointer	PM capability ID	DCh
Data	PMCSR bridge support	Power management control/status		E0h
Reserved	Hot swap control status	HS next item pointer	HS capability ID	E4h
Reserved				E8h–EFh
Reserved			Diagnostics	F0
Reserved				F4–FF

PCI2050A PCI-to-PCI BRIDGE

SCPS067 – MAY 2001

bridge configuration header (continued)

status register

The bit 5 in status register is hardwired to 0 in PCI2050. However, in PCI2050A it indicates whether the primary PCI interface is 66-MHz capable or not.

Bit	15	14	13	12	11	10	9	8	7	6	5	4	3	2	1	0
Name	Status															
Type	R/W	R/W	R/W	R/W	R/W	R	R	R/W	R	R	R	R	R	R	R	R
Default	0	0	0	0	0	0	1	0	1	0	0	1	0	0	0	0

Register: **Status**
 Type: Read-only, read/write (see individual bit descriptions)
 Offset: 06h
 Default: 0290h

Table 2. Status Register

BIT	TYPE	FUNCTION
15-6	Same as PCI2050	Same as PCI2050.
5	R	66-MHz capable. Bit 5 indicates whether the primary interface is 66 MHz capable. It reads as 0 when CONFIG66 is tied low to indicate that PCI2050A is not 66-MHz capable and reads as 1 when CONFIG66 is tied high to indicate that the primary bus is 66-MHz capable.
4-0	Same as PCI2050	Same as PCI2050.

revision ID register

The revision ID register indicates the silicon version of PCI2050A.

Bit	7	6	5	4	3	2	1	0
Name	Revision ID							
Type	R	R	R	R	R	R	R	R
Default	0	0	0	0	0	0	0	1

Register: **Revision ID**
 Type: Read-only
 Offset: 08h
 Default: 01h



bridge configuration header (continued)

secondary status register

The bit 5 in the status register is hardwired to 0 in PCI2050. However, in PCI2050A it indicates whether the primary PCI interface is 66-MHz capable.

Bit	15	14	13	12	11	10	9	8	7	6	5	4	3	2	1	0
Name	Secondary Status															
Type	R/W	R/W	R/W	R/W	R/W	R	R	R/W	R	R	R	R	R	R	R	R
Default	0	0	0	0	0	0	1	0	0	0	0	0	0	0	0	0

Register: **Secondary Status**
 Type: Read-only, read/write (see individual bit descriptions)
 Offset: IEh
 Default: 0200

Table 3. Status Register

BIT	TYPE	FUNCTION
15-6	Same as PCI2050	Same as PCI2050.
5	R	66-MHz capable. Bit 5 indicates whether the primary interface is 66-MHz capable. It reads as 0 when CONFIG66 is tied low to indicate that PCI2050A is not 66 MHz capable and reads as 1 when CONFIG66 is tied high to indicate that the primary bus is 66-MHz capable.
4-0	Same as PCI2050	Same as PCI2050.

extension registers

The extension registers for PCI2050A are exactly the same as the extension registers for PCI2050 except for the following registers.

diagnostics register

The register is used to enable or disable posted write combining of PCI2050A.

Bit	15	14	13	12	11	10	9	8	7	6	5	4	3	2	1	0
Name	TI Diagnostics															
Type	R	R	R	R	R	R	R	R	R	R	R	R	R	R	R	R/W
Default	0	0	0	0	0	0	1	0	0	0	0	0	0	0	0	0

Register: TI Diagnostics
 Type: Read-only, read/write (see individual bit descriptions)
 Offset: F0h
 Default: 0000h

Table 4. TI Diagnostics Register

BIT	TYPE	FUNCTION
15-6	R	Reserved. Bit 15–1 return 0s when read.
0	R/W	Disable posted write combining. 0: Enable posted write combining (Default) 1: Disable posted write combining

electrical data

66-MHz PCI clock signal ac parameters

The ac specification consists of input requirements and output responses. The input requirements consists of setup and hold times, pulse widths, and high and low times. Output responses are delays from clock to signal. The ac specifications are defined separately for each clock domain within the PCI2050A.

Figure 1 shows the ac parameters measurements for P_CLK and S_CLK signals.

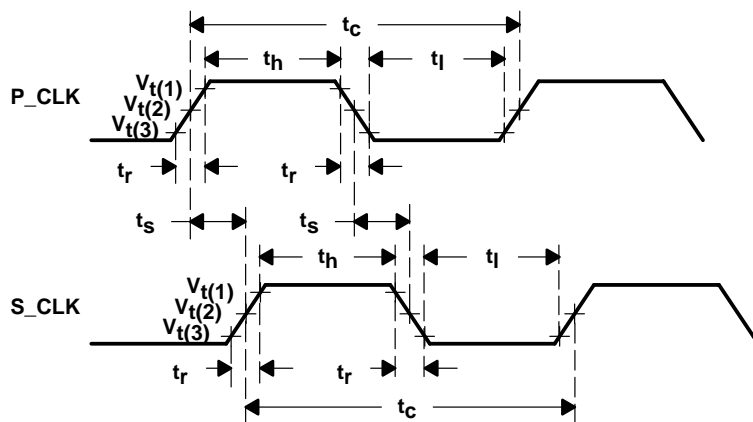

NOTE: $V_{t(1)}$ – 2.0 V for 5-V clocks; 0.5 V_{CC} for 3.3-V clocks
 $V_{t(2)}$ – 1.5 V for 5-V clocks; 0.4 V_{CC} for 3.3-V clocks
 $V_{t(3)}$ – 0.8 V for 5-V clocks; 0.3 V_{CC} for 3.3-V clocks

Figure 1. PCI Clock Signal AC Parameter Measurements

66 MHz PCI clock signal ac parameters

PARAMETER	MIN	MAX	UNIT
t_c P_CLK, S_CLK cycle time	15	30	ns
$t_{(h)}$ P_CLK, S_CLK high time	6		ns
$t_{(l)}$ P_CLK, S_CLK low time	6		ns
$t_{(PSS)}$ P_CLK, S_CLK slew rate (0.2 V_{cc} to 0.6 V_{cc})	1.5	4	V/ns
$t_{d(SCLK)}$ Delay from P_CLK to S_CLK	0	7	ns
$t_{r(SCLK)}$ P_CLK rising to S_CLK rising	0	7	ns
$t_{f(SCLK)}$ P_CLK falling to S_CLK falling	0	7	ns
$t_{d(skew)}$ S_CLK0 duty cycle skew from P_CLK duty cycle		0.750	ns
t_{sk} S_CLKx to SCLKy		0.500	ns

electrical data (continued)

66-MHz PCI signal timing specifications

Figure 2 illustrates the PCI signal timing specification.

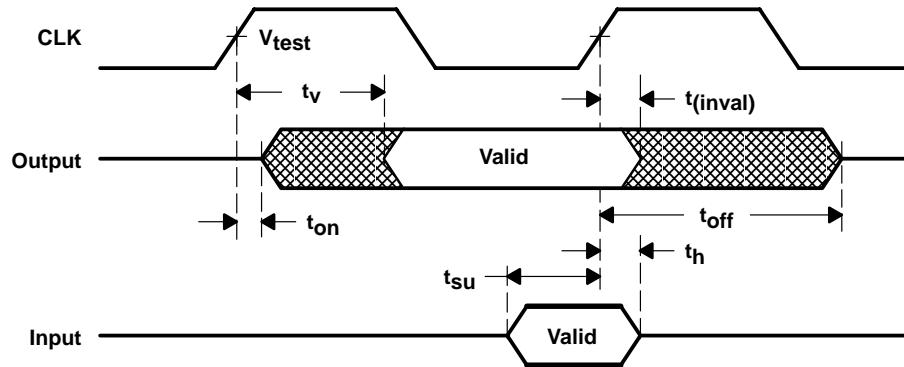

NOTE: V_{test} – 1.5 V for 5-V signals; 0.4 V_{CC} for 3.3-V signals

Figure 2. PCI Signal Timing Measurement Conditions

66-MHz PCI signal timing

PARAMETER		MIN	MAX	UNIT
$t_{v(bus)}$	CLK to signal valid delay - bused signals (see Notes 1, 2, and 3)	2	6	ns
$t_{v(ftp)}$	CLK to signal valid delay – point to point (see Notes 1, 2, and 3)	2	6	ns
t_{on}	Float to active delay (see Notes 1, 2, and 3)	2		ns
t_{off}	Active to float delay (see Notes 1, 2, and 3)		14	ns
$t_{su(bus)}$	Input setup time to CLK– bused signal (see Notes 1, 2, and 3)	3		ns
$t_{su(ftp)}$	Input setup time to CLK – point-to-point (see Notes 1, 2, and 3)	5		ns
t_h	Input signal hold time from CLK (see Notes 1 and 2)	0		ns

- NOTES: 1. See Figure 2
 2. All primary interface signals are synchronized to P_CLK and all secondary interface signals are synchronized to S_CLK.
 3. Bused signals are as follows:
P_AD, P_C/BE, P_PAR, P_PERR, P_SERR, P_FRAME, P_IRDY, P_TRDY, P_LOCK, P_DEVSEL, P_STOP, P_IDSEL, S_AD, S_C/BE, S_PAR, S_PERR, S_SERR, S_FRAME, S_IRDY, S_TRDY, S_LOCK, S_DEVSEL, S_STOP

Point-to-point signals are as follows:
P_REQ, S_REQx, P_GNT, S_GNTx

PCI2050A
PCI-to-PCI BRIDGE

SCPS067 – MAY 2001

MECHANICAL DATA

PDV (S-PQFP-G208)

PLASTIC QUAD FLATPACK

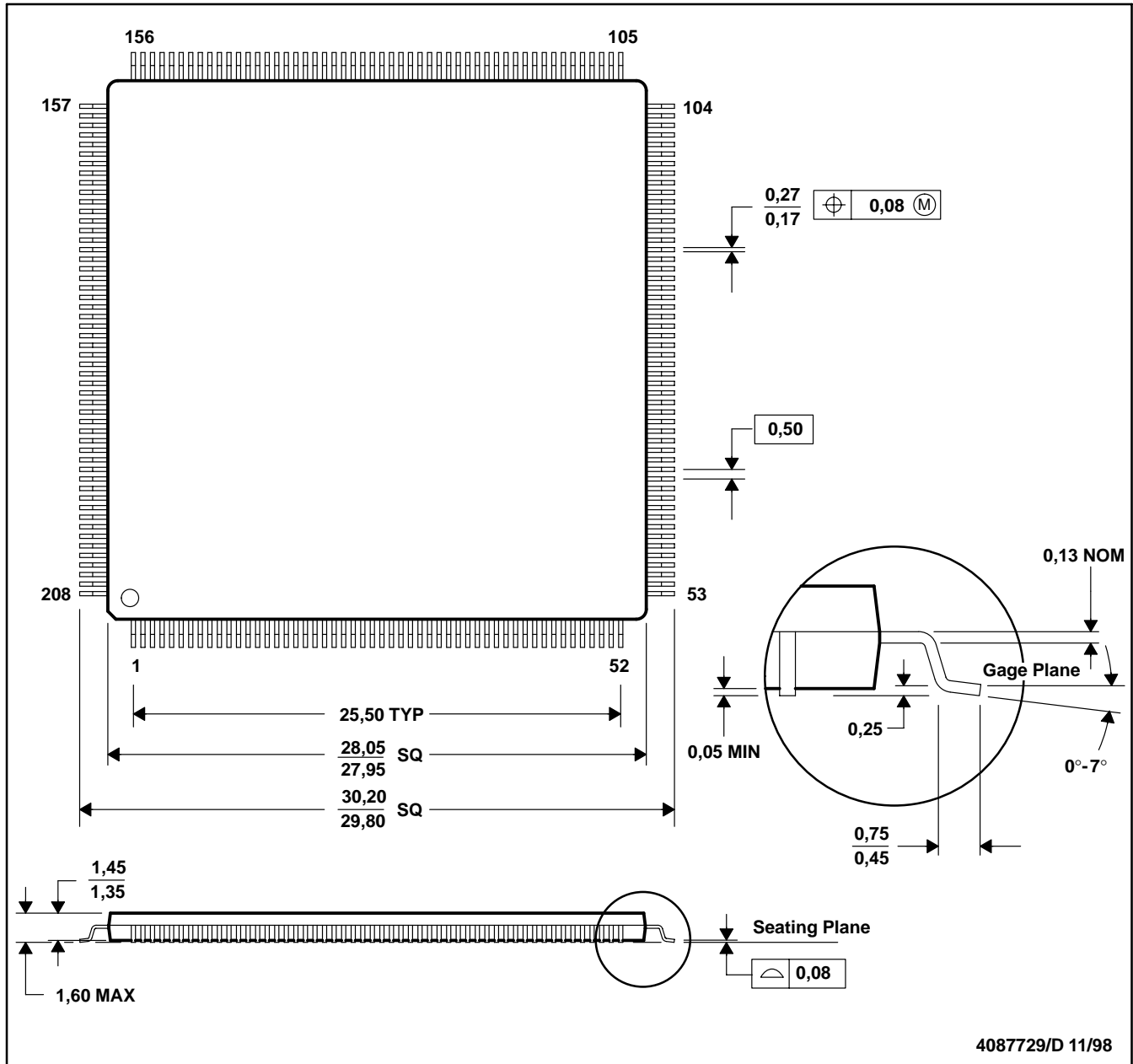

- NOTES: A. All linear dimensions are in millimeters.
 B. This drawing is subject to change without notice.
 C. Falls within JEDEC MS-026

IMPORTANT NOTICE

Texas Instruments and its subsidiaries (TI) reserve the right to make changes to their products or to discontinue any product or service without notice, and advise customers to obtain the latest version of relevant information to verify, before placing orders, that information being relied on is current and complete. All products are sold subject to the terms and conditions of sale supplied at the time of order acknowledgment, including those pertaining to warranty, patent infringement, and limitation of liability.

TI warrants performance of its products to the specifications applicable at the time of sale in accordance with TI's standard warranty. Testing and other quality control techniques are utilized to the extent TI deems necessary to support this warranty. Specific testing of all parameters of each device is not necessarily performed, except those mandated by government requirements.

Customers are responsible for their applications using TI components.

In order to minimize risks associated with the customer's applications, adequate design and operating safeguards must be provided by the customer to minimize inherent or procedural hazards.

TI assumes no liability for applications assistance or customer product design. TI does not warrant or represent that any license, either express or implied, is granted under any patent right, copyright, mask work right, or other intellectual property right of TI covering or relating to any combination, machine, or process in which such products or services might be or are used. TI's publication of information regarding any third party's products or services does not constitute TI's approval, license, warranty or endorsement thereof.

Reproduction of information in TI data books or data sheets is permissible only if reproduction is without alteration and is accompanied by all associated warranties, conditions, limitations and notices. Representation or reproduction of this information with alteration voids all warranties provided for an associated TI product or service, is an unfair and deceptive business practice, and TI is not responsible nor liable for any such use.

Resale of TI's products or services with statements different from or beyond the parameters stated by TI for that product or service voids all express and any implied warranties for the associated TI product or service, is an unfair and deceptive business practice, and TI is not responsible nor liable for any such use.

Also see: [Standard Terms and Conditions of Sale for Semiconductor Products](http://www.ti.com/sc/docs/stdterms.htm). www.ti.com/sc/docs/stdterms.htm

Mailing Address:

Texas Instruments
Post Office Box 655303
Dallas, Texas 75265