

- **High-Performance Floating-Point Digital Signal Processor (DSP):**
 - SM/SMJ320VC33-150
 - 13-ns Instruction Cycle Time
 - 150 Million Floating-Point Operations Per Second (MFLOPS)
 - 75 Million Instructions Per Second (MIPS)
- **34K × 32-Bit (1.1-Mbit) On-Chip Words of Dual-Access Static Random-Access Memory (SRAM) Configured in 2 × 16K plus 2 × 1K Blocks to improve Internal Performance**
- **x5 Phase-Locked Loop (PLL) Clock Generator**
- **Very Low Power: < 200 mW @ 150 MFLOPS**
- **32-Bit High-Performance CPU**
- **16-/32-Bit Integer and 32-/40-Bit Floating-Point Operations**
- **Four Internally Decoded Page Strokes to Simplify Interface to I/O and Memory Devices**
- **Boot-Program Loader**
- **EDGEMODE Selectable External Interrupts**
- **32-Bit Instruction Word, 24-Bit Addresses**
- **Eight Extended-Precision Registers**
- **Fabricated Using the 0.18- μ m (I_{eff} -Effective Gate Length) TImeline™ Technology by Texas Instruments (TI)**
- **On-Chip Memory-Mapped Peripherals:**
 - One Serial Port
 - Two 32-Bit Timers
 - Direct Memory Access (DMA) Coprocessor for Concurrent I/O and CPU Operation
- **164-Pin Low-Profile Quad Flatpack (HFG Suffix)**
- **144-Pin Non-hermetic Ceramic Ball Grid Array (CBGA) (GNM Suffix)**
- **Two Address Generators With Eight Auxiliary Registers and Two Auxiliary Register Arithmetic Units (ARAUs)**
- **Two Low-Power Modes**
- **Two- and Three-Operand Instructions**
- **Parallel Arithmetic/Logic Unit (ALU) and Multiplier Execution in a Single Cycle**
- **Block-Repeat Capability**
- **Zero-Overhead Loops With Single-Cycle Branches**
- **Conditional Calls and Returns**
- **Interlocked Instructions for Multiprocessing Support**
- **Bus-Control Registers Configure Strobe-Control Wait-State Generation**
- **1.8-V (Core) and 3.3-V (I/O) Supply Voltages**

description

The SM/SMJ320VC33 DSP is a 32-bit, floating-point processor manufactured in 0.18- μ m four-level-metal CMOS (TImeline) technology. The SM/SMJ320VC33 is part of the SM320C3x™ generation of DSPs from Texas Instruments.

The SM320C3x internal busing and special digital-signal-processing instruction set have the speed and flexibility to execute up to 150 million floating-point operations per second (MFLOPS). The SM/SMJ320VC33 optimizes speed by implementing functions in hardware that other processors implement through software or microcode. This hardware-intensive approach provides performance previously unavailable on a single chip.



Please be aware that an important notice concerning availability, standard warranty, and use in critical applications of Texas Instruments semiconductor products and disclaimers thereto appears at the end of this data sheet.

TImeline and SM320C3x are trademarks of Texas Instruments.

PRODUCTION DATA information is current as of publication date. Products conform to specifications per the terms of Texas Instruments standard warranty. Production processing does not necessarily include testing of all parameters.



POST OFFICE BOX 1443 • HOUSTON, TEXAS 77251-1443

Copyright © 2002, Texas Instruments Incorporated
On products compliant to MIL-PRF-38535, all parameters are tested unless otherwise noted. On all other products, production processing does not necessarily include testing of all parameters.

SM320VC33, SMJ320VC33 DIGITAL SIGNAL PROCESSOR

SGUS034E - FEBRUARY 2001 - REVISED OCTOBER 2002

description (continued)

The SM/SMJ320VC33 can perform parallel multiply and ALU operations on integer or floating-point data in a single cycle. Each processor also possesses a general-purpose register file, a program cache, dedicated ARAUs, internal dual-access memories, one DMA channel supporting concurrent I/O, and a short machine-cycle time. High performance and ease of use are the results of these features.

General-purpose applications are greatly enhanced by the large address space, multiprocessor interface, internally and externally generated wait states, one external interface port, two timers, one serial port, and multiple-interrupt structure. The SM320C3x supports a wide variety of system applications from host processor to dedicated coprocessor. High-level-language support is easily implemented through a register-based architecture, large address space, powerful addressing modes, flexible instruction set, and well-supported floating-point arithmetic.

JTAG scan-based emulation logic

The 320VC33 contains a JTAG port for CPU emulation within a chain of any number of other JTAG devices. The JTAG port on this device does not include a pin-by-pin boundary scan for point-to-point board level test. The Boundary Scan tap input and output is internally connected with a single dummy register allowing loop back tests to be performed through that JTAG domain.

The JTAG emulation port of this device also includes two additional pins, EMU0 and EMU1, for global control of multiple processors conforming to the TI emulation standard. These pins are open collector-type outputs which are wire ORed and tied high with a pullup. Non-TI emulation devices should not be connected to these pins.

The VC33 instruction register is 8 bits long. Table 1 shows the instructions code. The uses of SAMPLE and HIGHZ opcodes, though defined, have no meaning for the SM/SMJ320VC33, which has no boundary scan. For example, HIGHZ will affect only the dummy cell (no meaning) and will not put the device pins in a high-impedance state.

Table 1. Boundary-Scan Instruction Code

INSTRUCTION NAME	INSTRUCTION CODE
EXTEST	00000000
BYPASS	11111111
SAMPLE	00000010
HIGHZ	00000110
PRIVATE1†	00000011
PRIVATE2†	00100000
PRIVATE3†	00100001
PRIVATE4†	00100010
PRIVATE5†	00100011
PRIVATE6†	00100100
PRIVATE7†	00100101
PRIVATE8†	00100110
PRIVATE9†	00100111
PRIVATE10†	00101000
PRIVATE11†	00101001

Boundry is only one dummy cell
Boundry is only one dummy cell

† Use of Private opcodes could cause the device to operate in an unexpected manner.



SM320VC33, SMJ320VC33 DIGITAL SIGNAL PROCESSOR

SGUS034E - FEBRUARY 2001 - REVISED OCTOBER 2002

pinout

HFG PACKAGE†‡ (TOP VIEW)

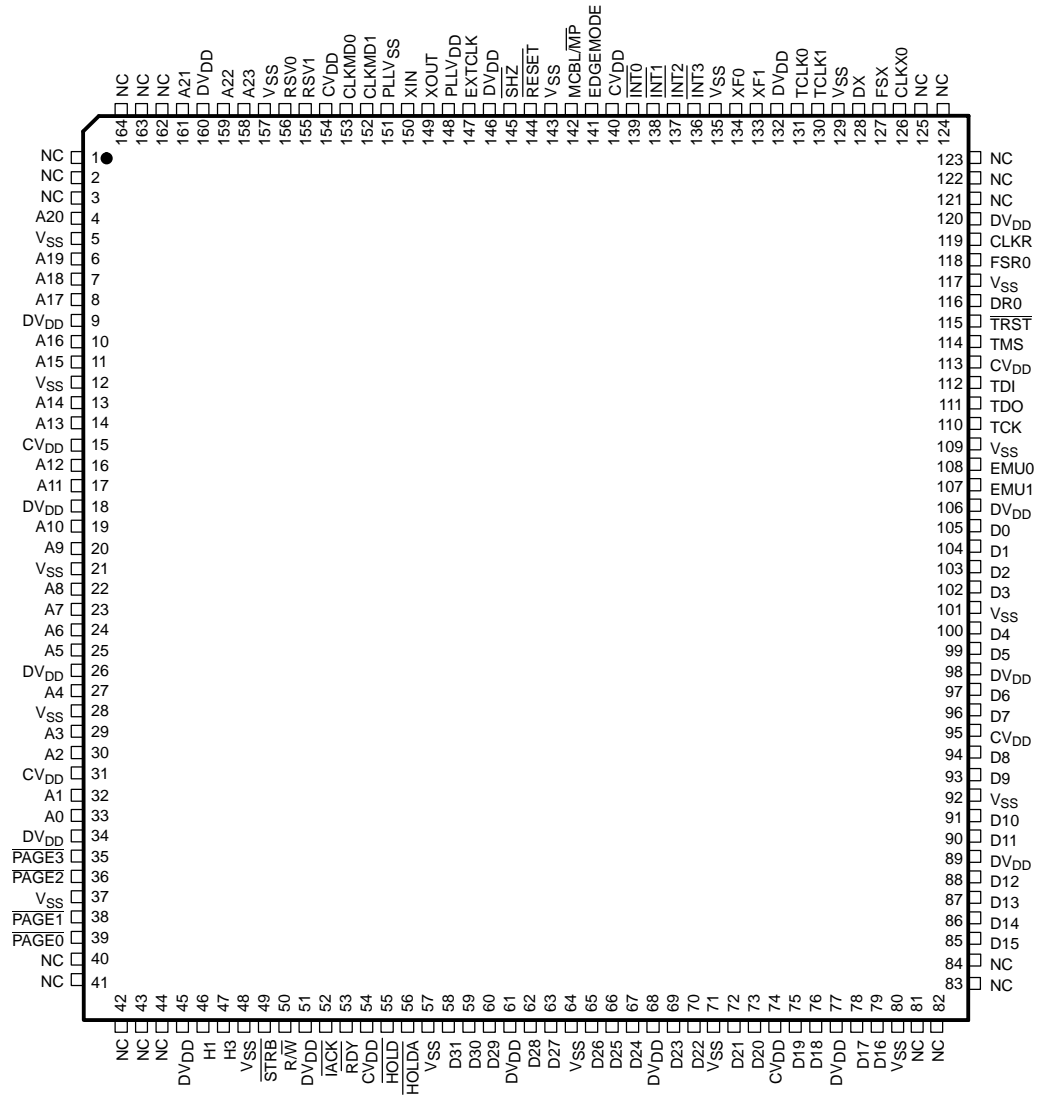

NC - No internal connection

† DV_{DD} is the power supply for the I/O pins while CV_{DD} is the power supply for the core CPU. V_{SS} is the ground for both the I/O pins and the core CPU.

‡ PLLV_{DD} and PLLV_{SS} are isolated PLL supply pins that should be externally connected to CV_{DD} and V_{SS}, respectively.

The SM/SMJ320VC33 device is packaged in 164-pin low-profile quad flatpacks (HFG Suffix) and in 144-ball fine pitch ball grid arrays (GNL and GNM Suffix).



SM320VC33, SMJ320VC33 DIGITAL SIGNAL PROCESSOR

SGUS034E - FEBRUARY 2001 - REVISED OCTOBER 2002

GNM Terminal Assignments† (Sorted by Signal Name)

SIGNAL NAME	PIN NUMBER	SIGNAL NAME	PIN NUMBER	SIGNAL NAME	PIN NUMBER	SIGNAL NAME	PIN NUMBER
A0	J2	D0	G12	DV _{DD}	M1	R/W	L4
A1	K2	D1	G10		N1	RDY	M5
A2	K1	D2	F13		N4	RESET	B7
A3	J4	D3	G11		N7	RSV0	B4
A4	H4	D4	H10		M8	RSV1	D5
A5	H3	D5	H13		N12	SHZ	D7
A6	H1	D6	H12		L13	STRB	M4
A7	G4	D7	J10		H11	TCK	F10
A8	G1	D8	J11		F11	TCLK0	C10
A9	G2	D9	J12		B12	TCLK1	A11
A10	F3	D10	K13		A10	TDI	E11
A11	F4	D11	K12		A6	TDO	D13
A12	F2	D12	K10		A1	TMS	E10
A13	E1	D13	M13		DX0	A12	TRST
A14	E2	D14	L11	EDGEMODE	A7	V _{SS}	B1
A15	E4	D15	L12	EMU0	F12		D1
A16	C1	D16	M12	EMU1	E12		G3
A17	C2	D17	L10	EXTCLK	C6		J1
A18	D3	D18	K9	FSR0	C12		L2
A19	C3	D19	N11	FSX	D10		M3
A20	B2	D20	M11	H1	L3		M6
A21	D4	D21	M10	H3	N2		L7
A22	A2	D22	K8	HOLD	N5		N10
A23	B3	D23	N9	HOLDA	K5		N13
CLKMD0	C5	D24	M9	IACK	K4		K11
CLKMD1	B5	D25	L8	INT0	C8		G13
CLKR0	B13	D26	N8	INT1	B9		E13
CLKX0	B11	D27	M7	INT2	D8		A13
CV _{DD}	E3	D28	K7	INT3	A9		C11
	J3	D29	L6	MCBL/MP	B8		C9
	L5	D30	N6	PAGE0	M2		C7
	L9	D31	K6	PAGE1	N3	C4	
	J13	DR0	D11	PAGE2	L1	XF0	B10
	D12	DV _{DD}	D2	PAGE3	K3	XF1	D9
	A8		F1	PLL _{VDD} ‡	A5	XIN	B6
A3	H2		PLL _{VSS} ‡	A4	XOUT	D6	

† DV_{DD} is the power supply for the I/O pins while CV_{DD} is the power supply for the core CPU. V_{SS} is the ground for both the I/O pins and the core CPU.

‡ PLL_{VDD} and PLL_{VSS} are isolated PLL supply pins that should be externally connected to CV_{DD} and V_{SS}, respectively.

GNM Terminal Assignments† (Sorted by Pin Number)

PIN NUMBER	SIGNAL NAME	PIN NUMBER	SIGNAL NAME	PIN NUMBER	SIGNAL NAME	PIN NUMBER	SIGNAL NAME
A1	DV _{DD}	C11	V _{SS}	G10	D1	L4	R/W
A2	A22	C12	FSR0	G11	D3	L5	CV _{DD}
A3	CV _{DD}	C13	TRST	G12	D0	L6	D29
A4	PLL _{VSS}	D1	V _{SS}	G13	V _{SS}	L7	V _{SS}
A5	PLL _{VDD}	D2	DV _{DD}	H1	A6	L8	D25
A6	DV _{DD}	D3	A18	H2	DV _{DD}	L9	CV _{DD}
A7	EDGEMODE	D4	A21	H3	A5	L10	D17
A8	CV _{DD}	D5	RSV1	H4	A4	L11	D14
A9	INT3	D6	XOUT	H10	D4	L12	D15
A10	DV _{DD}	D7	SHZ	H11	DV _{DD}	L13	DV _{DD}
A11	TCLK1	D8	INT2	H12	D6	M1	DV _{DD}
A12	DX	D9	XF1	H13	D5	M2	PAGE0
A13	V _{SS}	D10	FSX	J1	V _{SS}	M3	V _{SS}
B1	V _{SS}	D11	DR0	J2	A0	M4	STRB
B2	A20	D12	CV _{DD}	J3	CV _{DD}	M5	RDY
B3	A23	D13	TDO	J4	A3	M6	V _{SS}
B4	RSV0	E1	A13	J10	D7	M7	D27
B5	CLKMD1	E2	A14	J11	D8	M8	DV _{DD}
B6	XIN	E3	CV _{DD}	J12	D9	M9	D24
B7	RESET	E4	A15	J13	CV _{DD}	M10	D21
B8	MCBL/MP	E10	TMS	K1	A2	M11	D20
B9	INT1	E11	TDI	K2	A1	M12	D16
B10	XF0	E12	EMU1	K3	PAGE3	M13	D13
B11	CLKX0	E13	V _{SS}	K4	IACK	N1	DV _{DD}
B12	DV _{DD}	F1	DV _{DD}	K5	HOLDA	N2	H3
B13	CLKR	F2	A12	K6	D31	N3	PAGE1
C1	A16	F3	A10	K7	D28	N4	DV _{DD}
C2	A17	F4	A11	K8	D22	N5	HOLD
C3	A19	F10	TCK	K9	D18	N6	D30
C4	V _{SS}	F11	DV _{DD}	K10	D12	N7	DV _{DD}
C5	CLKMD0	F12	EMU0	K11	V _{SS}	N8	D26
C6	EXTCLK	F13	D2	K12	D11	N9	D23
C7	V _{SS}	G1	A8	K13	D10	N10	V _{SS}
C8	INT0	G2	A9	L1	PAGE2	N11	D19
C9	V _{SS}	G3	V _{SS}	L2	V _{SS}	N12	DV _{DD}
C10	TCLK0	G4	A7	L3	H1	N13	V _{SS}

† DV_{DD} is the power supply for the I/O pins while CV_{DD} is the power supply for the core CPU. V_{SS} is the ground for both the I/O pins and the core CPU.

‡ PLL_{VDD} and PLL_{VSS} are isolated PLL supply pins that should be externally connected to CV_{DD} and V_{SS}, respectively.

SM320VC33, SMJ320VC33 DIGITAL SIGNAL PROCESSOR

SGUS034E - FEBRUARY 2001 - REVISED OCTOBER 2002

Terminal Functions

TERMINAL NAME	QTY	TYPE†	DESCRIPTION	CONDITIONS WHEN SIGNAL IS Z TYPE‡
PRIMARY-BUS INTERFACE				
D31- D0	32	I/O/Z	32-bit data port Data port bus keepers. (See Figure 9)	S H R S
A23- A0	24	O/Z	24-bit address port	S H R
R/W	1	O/Z	Read/write. R/W is high when a read is performed and low when a write is performed over the parallel interface.	S H R
STRB	1	O/Z	Strobe. For all external-accesses	S H
PAGE0 - PAGE3	1	O/Z	Page strobes. Four decoded page strobes for external access	S H R
RDY	1	I	Ready. RDY indicates that the external device is prepared for a transaction completion.	
HOLD	1	I	Hold. When HOLD is a logic low, any ongoing transaction is completed. A23- A0, D31-D0, STRB, and R/W are placed in the high-impedance state and all transactions over the primary-bus interface are held until HOLD becomes a logic high or until the NOHOLD bit of the primary-bus-control register is set.	
HOLDA	1	O/Z	Hold acknowledge. HOLDA is generated in response to a logic-low on HOLD. HOLDA indicates that A23-A0, D31-D0, STRB, and R/W are in the high-impedance state and that all transactions over the bus are held. HOLDA is high in response to a logic-high of HOLD or the NOHOLD bit of the primary-bus-control register is set.	S
CONTROL SIGNALS				
RESET	1	I	Reset. When RESET is a logic low, the device is in the reset condition. When RESET becomes a logic high, execution begins from the location specified by the reset vector.	
EDGEMODE	1	I	Edge mode. Enables interrupt edge mode detection.	
INT3- INT0	4	I	External interrupts	
IACK	1	O/Z	Internal acknowledge. IACK is generated by the IACK instruction. IACK can be used to indicate when a section of code is being executed.	S
MABL/MP	1	I	Microcomputer Bootloader/microprocessor mode-select	
SHZ	1	I	Shutdown high impedance. When active, SHZ places all pins in the high-impedance state. SHZ can be used for board-level testing or to ensure that no dual-drive conditions occur. CAUTION: A low on SHZ corrupts the device memory and register contents. Reset the device with SHZ high to restore it to a known operating condition.	
XF1, XF0	2	I/O/Z	External flags. XF1 and XF0 are used as general-purpose I/Os or to support interlocked processor instruction.	S R
SERIAL PORT 0 SIGNALS				
CLKR0	1	I/O/Z	Serial port 0 receive clock. CLKR0 is the serial shift clock for the serial port 0 receiver.	S R
CLKX0	1	I/O/Z	Serial port 0 transmit clock. CLKX0 is the serial shift clock for the serial port 0 transmitter.	S R
DR0	1	I/O/Z	Data-receive. Serial port 0 receives serial data on DR0.	S R
DX0	1	I/O/Z	Data-transmit output. Serial port 0 transmits serial data on DX0.	S R
FSR0	1	I/O/Z	Frame-synchronization pulse for receive. The FSR0 pulse initiates the data-receive process using DR0.	S R
FSX0	1	I/O/Z	Frame-synchronization pulse for transmit. The FSX0 pulse initiates the data-transmit process using DX0.	S R

† I = input, O = output, Z = high-impedance state

‡ S = SHZ active, H = HOLD active, R = RESET active

§ Recommended decoupling. Four 0.1 µF for CV_{DD} and eight 0.1 µF for DV_{DD}.



Terminal Functions (Continued)

TERMINAL NAME	QTY	TYPE†	DESCRIPTION	CONDITIONS WHEN SIGNAL IS Z TYPE‡
TIMER SIGNALS				
TCLK0	1	I/O/Z	Timer clock 0. As an input, TCLK0 is used by timer 0 to count external pulses. As an output, TCLK0 outputs pulses generated by timer 0.	S R
TCLK1	1	I/O/Z	Timer clock 1. As an input, TCLK1 is used by timer 1 to count external pulses. As an output, TCLK1 outputs pulses generated by timer 1.	S R
SUPPLY AND OSCILLATOR SIGNALS				
H1	1	O/Z	External H1 clock	S
H3	1	O/Z	External H3 clock	S
CV _{DD}	8	I	+V _{DD} . Dedicated 1.8-V power supply for the core CPU. All must be connected to a common supply plane.§	
DV _{DD}	16	I	+V _{DD} . Dedicated 3.3-V power supply for the I/O pins. All must be connected to a common supply plane.§	
V _{SS}	18	I	Ground. All grounds must be connected to a common ground plane.	
PLL _{VDD}	1	I	Internally isolated PLL supply. Connect to CV _{DD} (1.8 V)	
PLL _{VSS}	1	I	Internally isolated PLL ground. Connect to V _{SS}	
EXTCLK	1	I	External clock. Logic level compatible clock input. If the XIN/XOUT oscillator is used, tie this pin to ground.	
XOUT	1	O	Clock out. Output from the internal-crystal oscillator. If a crystal is not used, XOUT should be left unconnected.	
XIN	1	I	Clock in. Internal-oscillator input from a crystal. If EXTCLK is used, tie this pin to ground.	
CLKMD0, CLKMD1	2	I	Clock mode select pins	
RSV0 - RSV1	2	I	Reserved. Use individual pullups to DV _{DD} .	
JTAG EMULATION				
EMU1- EMU0	2	I/O	Emulation pins 0 and 1, use individual pullups to DV _{DD}	
TDI	1	I	Test data input	
TDO	1	O	Test data output	
TCK	1	I	Test clock	
TMS	1	I	Test mode select	
TRST	1	I	Test reset	

† I = input, O = output, Z = high-impedance state

‡ S = $\overline{\text{SHZ}}$ active, H = $\overline{\text{HOLD}}$ active, R = $\overline{\text{RESET}}$ active

§ Recommended decoupling. Four 0.1 μF for CV_{DD} and eight 0.1 μF for DV_{DD}.

SM320VC33, SMJ320VC33 DIGITAL SIGNAL PROCESSOR

SGUS034E - FEBRUARY 2001 - REVISED OCTOBER 2002

functional block diagram

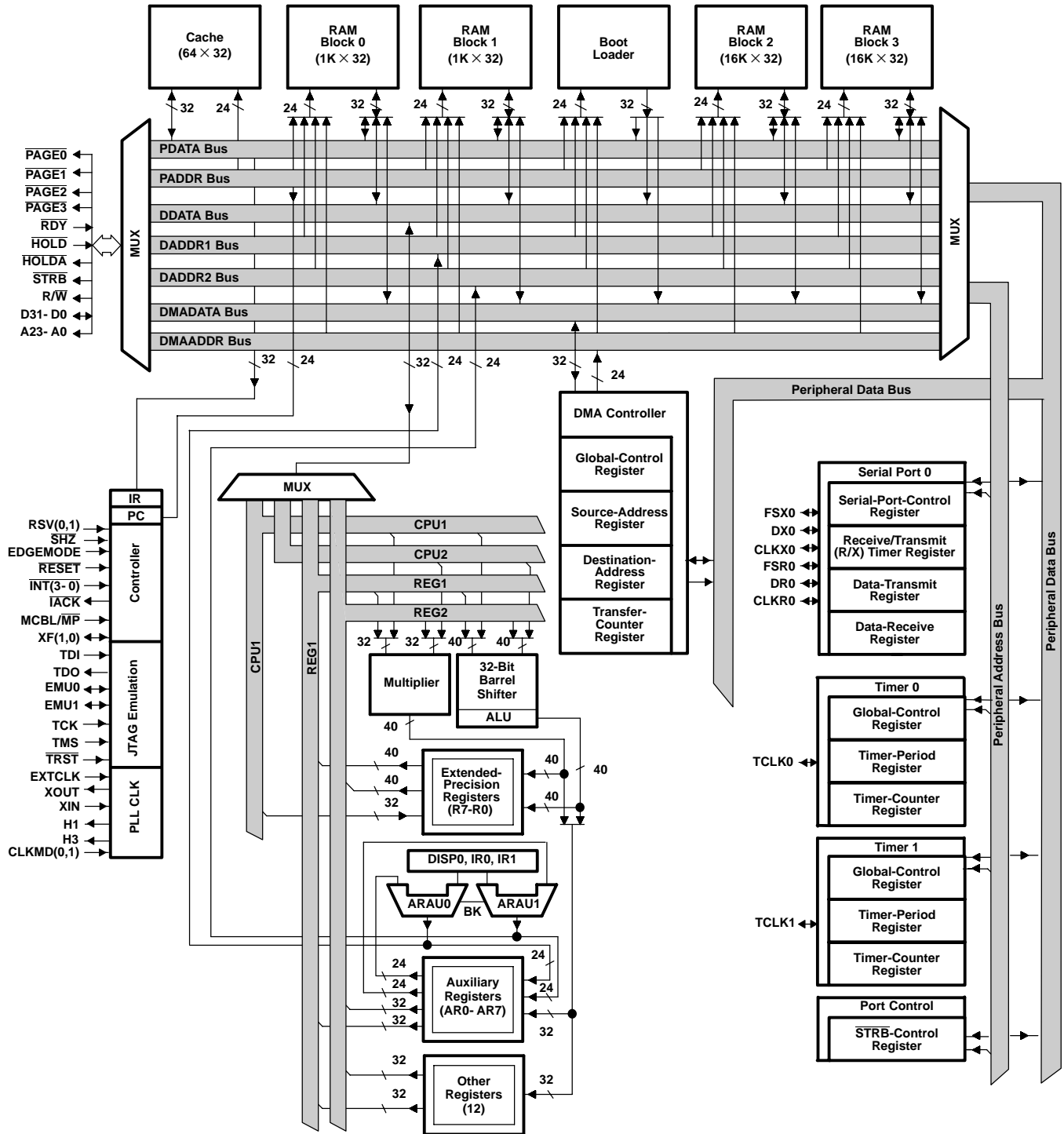

memory map

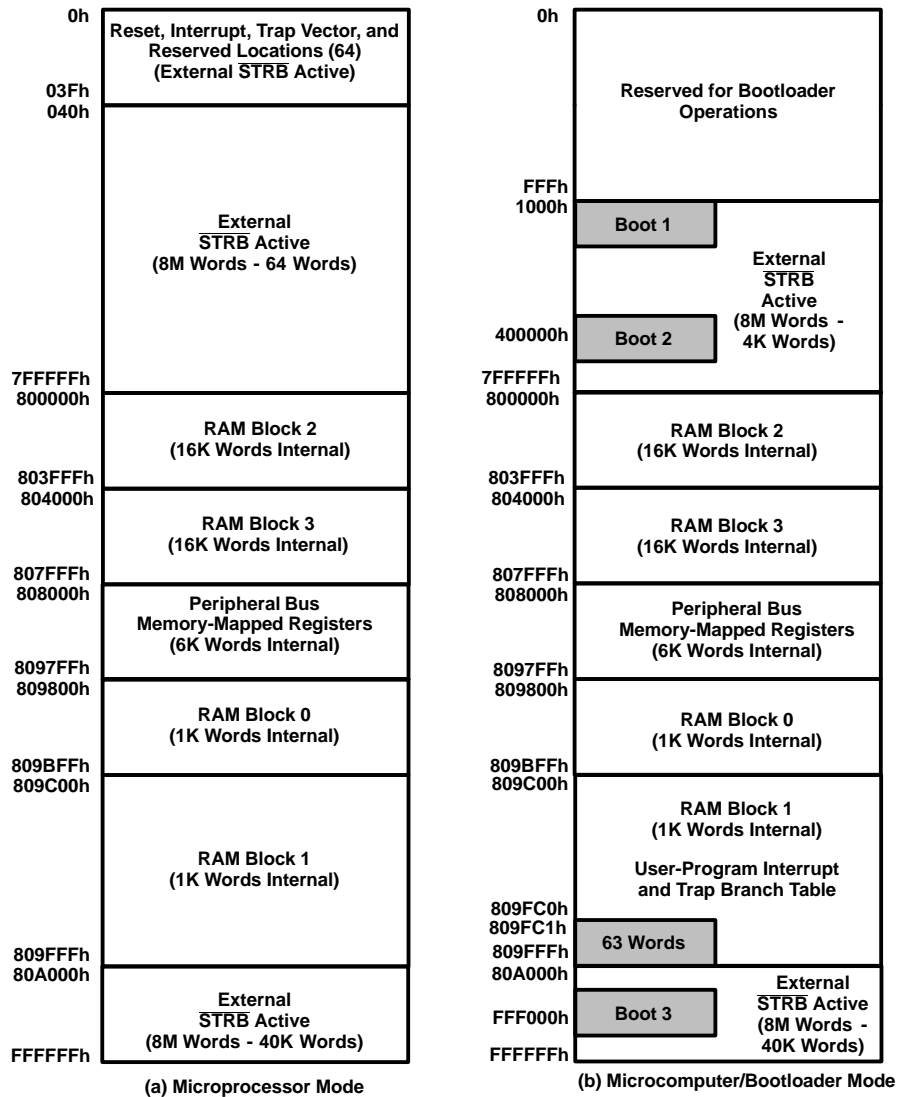

NOTE A: $\overline{\text{STRB}}$ is active over all external memory ranges. $\overline{\text{PAGE0}}$ to $\overline{\text{PAGE3}}$ are configured as external bus strobes. These are simple decoded strobes that have no configuration registers and are active only during external bus activity over the following ranges:

Name	Active range
$\overline{\text{PAGE0}}$	0000000h – 03FFFFFFh
$\overline{\text{PAGE1}}$	0400000h – 07FFFFFFh
$\overline{\text{PAGE2}}$	0800000h – 0BFFFFFFh
$\overline{\text{PAGE3}}$	0C00000h – 0FFFFFFh
$\overline{\text{STRB}}$	0000000h – 0FFFFFFh

Figure 1. SM/SMJ320VC33 Memory Maps

SM320VC33, SMJ320VC33 DIGITAL SIGNAL PROCESSOR

SGUS034E - FEBRUARY 2001 - REVISED OCTOBER 2002

memory map (continued)

00h	Reset
01h	INT0
02h	INT1
03h	INT2
04h	INT3
05h	XINT0
06h	RINT0
07h	Reserved
08h	
09h	TINT0
0Ah	TINT1
0Bh	DINT
0Ch	Reserved
1Fh	
20h	TRAP 0
	•
	•
	•
3Bh	TRAP 27
3Ch	Reserved
3Fh	

(a) Microprocessor Mode

809FC1h	INT0
809FC2h	INT1
809FC3h	INT2
809FC4h	INT3
809FC5h	XINT0
809FC6h	RINT0
809FC7h	Reserved
809FC8h	
809FC9h	TINT0
809FCAh	TINT1
809FCBh	DINT
809FCCh	Reserved
809FDFh	
809FE0h	TRAP 0
	•
	•
	•
809FFBh	TRAP 27
809FFCh	Reserved
809FFFh	

(b) Microcomputer/Bootloader Mode

Figure 2. Reset, Interrupt, and Trap Vector/Branches Memory-Map Locations

memory map (continued)

808000h	DMA Global Control
808004h	DMA Source Address
808006h	DMA Destination Address
808008h	DMA Transfer Counter
808020h	Timer 0 Global Control
808024h	Timer 0 Counter
808028h	Timer 0 Period Register
808030h	Timer 1 Global Control
808034h	Timer 1 Counter
808038h	Timer 1 Period Register
808040h	Serial Global Control
808042h	FSX/DX/CLKX Serial Port Control
808043h	FSR/DR/CLKR Serial Port Control
808044h	Serial R/X Timer Control
808045h	Serial R/X Timer Counter
808046h	Serial R/X Timer Period Register
808048h	Data-Transmit
80804Ch	Data-Receive
808064h	Primary-Bus Control

NOTE A: Shading denotes reserved address locations.

Figure 3. Peripheral Bus Memory-Mapped Registers

clock generator

The clock generator provides clocks to the VC33 device, and consists of an internal oscillator and a phase-locked loop (PLL) circuit. The clock generator requires a reference clock input, which can be provided by using a crystal resonator with the internal oscillator, or from an external clock source. The PLL circuit generates the device clock by multiplying the reference clock frequency by a x5 scale factor, allowing use of a clock source with a lower frequency than that of the CPU. The PLL is an adaptive circuit that, once synchronized, locks onto and tracks an input clock signal.

SM320VC33, SMJ320VC33 DIGITAL SIGNAL PROCESSOR

SGUS034E - FEBRUARY 2001 - REVISED OCTOBER 2002

PLL and clock oscillator control

The clock mode control pins are decoded into four operational modes as shown in Figure 4. These modes control clock divide ratios, oscillator, and PLL power (see Table 2).

When an external clock input or crystal is connected, the opposite unused input is simply grounded. An XOR gate then passes one of the two signal sources to the PLL stage. This allows the direct injection of a clock reference into EXTCLK, or 1-20 MHz crystals and ceramic resonators with the oscillator circuit. The two clock sources include:

- A crystal oscillator circuit, where a crystal or ceramic resonator is connected across the XOUT and XIN pins and EXTCLK is grounded.
- An external clock input, where an external clock source is directly connected to the EXTCLK pin, and XOUT is left unconnected and XIN is grounded.

When the PLL is initially started, it enters a transitional mode during which the PLL acquires lock with the input signal. Once the PLL is locked, it continues to track and maintain synchronization with the input signal. The PLL is a simple x5 reference multiplier with bypass and power control.

The clock divider, under CPU control, reduces the clock reference by 1 (MAXSPEED), 1/16 (LOWPOWER), or clock stop (IDLE2). Wake-up from the IDLE2 state is accomplished by a RESET or interrupt pin logic-low state.

A divide-by-two TMS320C31 equivalent mode of operation is also provided. In this case, the clock output reference is further divided by two with clock synchronization being determined by the timing of RESET falling relative to the present H1/H3 state.

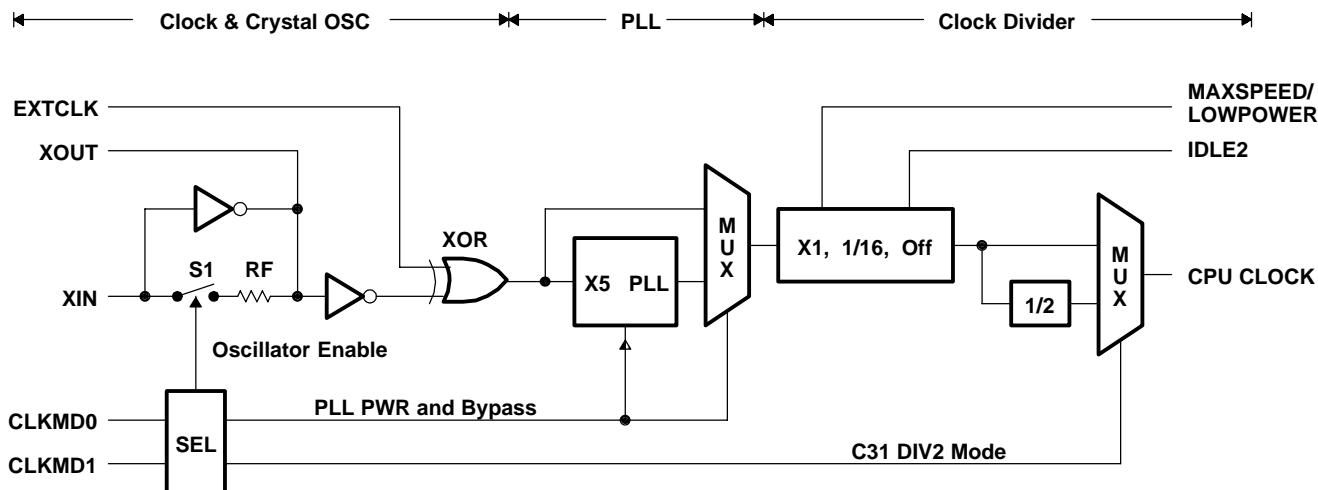

Figure 4. Clock Generation

Table 2. Clock Mode Select Pins

CLKMD0	CLKMD1	FEEDBACK	PLL PWR	RATIO	NOTES
0	0	Off	Off	1	Fully static, very low power
0	1	On	Off	1/2	Oscillator enabled
1	0	On	Off	1	Oscillator enabled
1	1	On	On	5	2 mA @ 60 MHz, 1.8 V PLL power. Oscillator enabled

PLL and clock oscillator control (continued)

Typical crystals in the 8-30 MHz range have a series resistance of 25 Ω , which increases below 8 MHz. To maintain proper filtering and phase relationships, R_d and Z_{out} of the oscillator circuit should be 10x-40x that of the crystal. A series compensation resistor (R_d), shown in Figure 5, is recommended when using lower frequency crystals. The XOUT output, the square wave inverse of XIN, is then filtered by the XOUT output impedance, C1 load capacitor, and R_d (if present). The crystal and C2 input load capacitor then refilters this signal, resulting in a XIN signal that is 75-85% of the oscillator supply voltage.

NOTE: Some ceramic resonators are available in a low-cost, three-terminal package that includes C1 and C2 internally. Typically, ceramic resonators do not provide the frequency accuracy of crystals.

NOTE: Better PLL stability can be achieved using the optional power supply isolation circuit shown in Figure 5. A similar filter can be used to isolate the PLLV_{SS}, as shown in Figure 6. PLLV_{DD} can also be directly connected to CV_{DD}.

Table 3. Typical Crystal Circuit Loading

FREQUENCY (MHz)	R _d (Ω)	C1 (pF)	C2 (pF)	CL [†] (pF)	RL [†] (Ω)
2	4.7k	18	18	12	200
5	2.2k	18	18	12	60
10	470	15	15	12	30
15	0	15	12	12	25
20	0	9	9	10	25

[†] CL and RL are typical internal series load capacitance and resistance of the crystal.

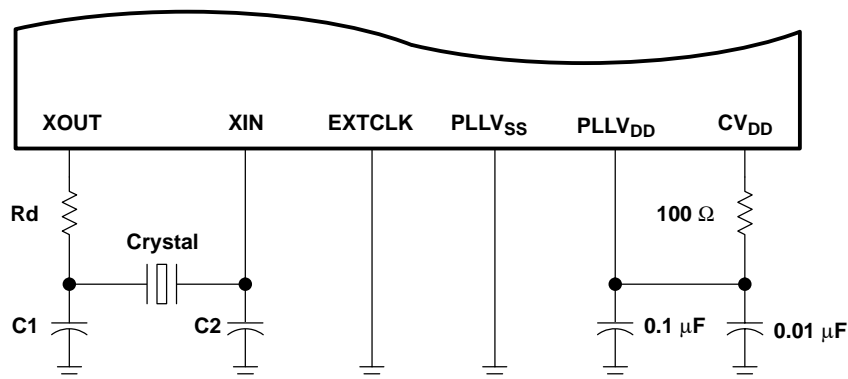

Figure 5. Self-Oscillation Mode

SM320VC33, SMJ320VC33 DIGITAL SIGNAL PROCESSOR

SGUS034E - FEBRUARY 2001 - REVISED OCTOBER 2002

PLL isolation

The internal PLL supplies can be directly connected to CV_{DD} and V_{SS} (0 Ω case) or fully isolated as shown in Figure 6. The RC network prevents the PLL supplies from turning high frequency noise in the CV_{DD} and V_{SS} supplies into jitter.

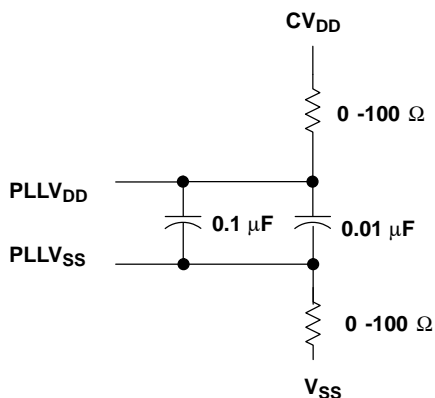

Figure 6. PLL Isolation Circuit Diagram

clock and PLL considerations on initialization

On power up, the CPU clock divide mode can be in MAXSPEED, LOPOWER or IDLE2, or the PLL could be in an undefined mode. \overline{RESET} falling in the presence of a valid CPU clock is used to clear this state, after which the device will synchronously terminate any external activity.

The 5x F_{clk} PLL of the 320VC33 contains an 8-bit PLL-LOCK counter that will cause the PLL to output a frequency of $F_{clk}/2$ during the initial ramp. This counter, however, does not increment while \overline{RESET} is low or in the absence of an input clock. A minimum of 256 input clocks are required before the first falling edge of reset for the PLL to output to clear this counter. The setup and behavior that is seen is as follows.

Power is applied to the DSP with \overline{RESET} low and the input clock high or low. A clock is applied (\overline{RESET} is still low) and the PLL appears to lock on to the input clock, producing the expected x5 output frequency. \overline{RESET} is driven high and the PLL output immediately drops to $F_{clk}/2$ for up to 256 input cycles or 128 of the $F_{clk}/2$ output cycles. The PLL/CPU clock then switches to x5 mode.

The switch over is synchronous and does not create a clock glitch, so the only effect is that the CPU will run slow for up to the first 128 cycles after reset goes high. Once the PLL has stabilized, the counter will remain cleared and subsequent resets will not exhibit this condition.

power sequencing considerations

Though an internal ESD and CMOS latchup protection diode exists between CV_{DD} and DV_{DD} , it should not be considered a current-carrying device on power up. An external Schottky diode should be used to prevent CV_{DD} from exceeding DV_{DD} by more than 0.7 V. The effect of this diode during power up is that if CV_{DD} is powered up first, DV_{DD} will follow by one diode drop even when the DV_{DD} supply is not active.

Typical systems using LDOs of the same family type for both DV_{DD} and CV_{DD} will track each other during power up. In most cases, this is acceptable; but if a high-impedance pin state is required on power up, the \overline{SHZ} pin can be used to asynchronously disable all outputs. \overline{RESET} should not be used in this case since some signals require an active clock for \overline{RESET} to have an effect and the clock may not yet be active. The internal core logic becomes functional at approximately 0.8 V while the external pin IO becomes active at about 1.5 V.

EDGEMODE

When EDGEMODE = 1, a sampled digital delay line is decoded to generate a pulse on the falling edge of the interrupt pin. To ensure interrupt recognition, input signal logic-high and logic-low states must be held longer than the synchronizer delay of one CPU clock cycle. Holding these inputs to no less than two cycles in both the logic-low and logic-high states is sufficient.

When EDGEMODE = 0, a logic-low interrupt pin will continually set the corresponding interrupt flag. The CPU or DMA can clear this flag within two cycles of it being set. This is the maximum interrupt width that can be applied if only one interrupt is to be recognized. The CPU can manually clear IF bits within an interrupt service routine (ISR), effectively lengthening the maximum ISR width.

After reset, EDGEMODE is temporarily disabled, allowing logic-low INT pins to be detected for bootload operation.

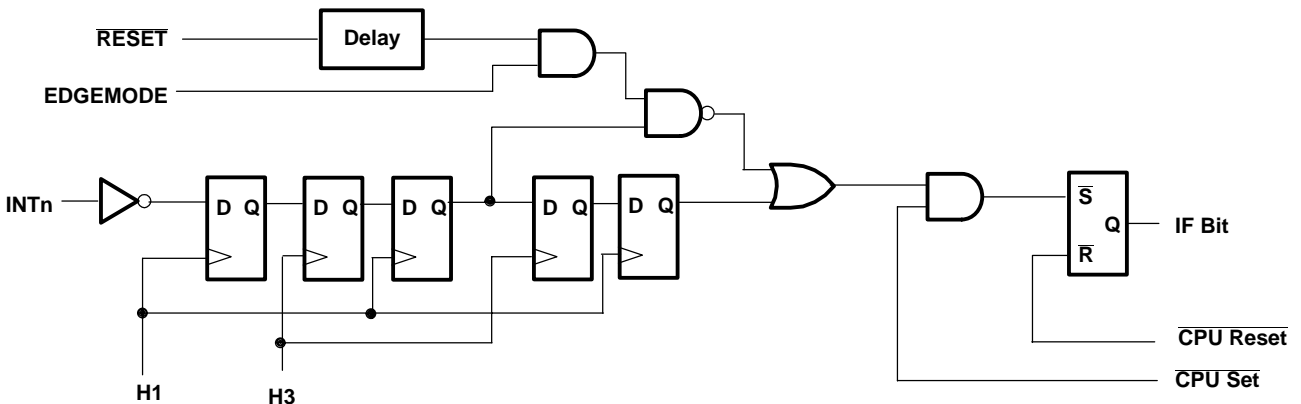

Figure 7. EDGEMODE and Interrupt Flag Circuit

reset operation

When RESET is applied, the CPU attempts to safely exit any pending read or write operations that may be in progress. This can take as much as 10 CPU cycles, after which, the address, data, and control pins will be in an inactive or high-impedance state.

When both RESET and SHZ are applied, the device will immediately enter the reset state with the pins held in high-impedance mode. SHZ should then be disabled at least 10 CPU cycles before RESET is set high. SHZ can be used during power-up sequencing to prevent undefined address, data, and control pins, avoiding system conflicts.

PAGE0 - PAGE3 select lines

To facilitate simpler and higher speed connection to external devices, the SM/SMJ320VC33 includes four predecoded select pins that have the same timings as STRB. These pins are decoded from A22, A23, and STRB and are active only during external accesses over the ranges shown in Table 4. All external bus accesses are controlled by a single bus control register.

Table 4. PAGE0 - PAGE3 Ranges

	START	END
PAGE0	0x000000	0x3FFFFFF
PAGE1	0x400000	0x7FFFFFF
PAGE2	0x800000	0xBFFFFFF
PAGE3	0xC00000	0xFFFFFFFF

example 2 (continued)

Table 5. MUX Select (Bus Control Register Bits 4 and 3)

BIT 4	BIT 3	RESULTS
0	0	Ignore internal wait counter and use only external $\overline{\text{READY}}$
0	1	Use only internal wait counter and ignore ready pin
1	0	Logically AND internal wait counter with ready pin
1	1	Logically OR internal wait counter with ready pin (reset default)

posted writes

External writes are effectively “posted” to the bus, which then acts like an output latch until the write completes. Therefore, if the application code is executing internally, it can perform a very slow external write with no penalty since the bus acts like it has a one-level-deep write FIFO.

data bus I/O buffer

The circuit shown in Figure 9 is incorporated into each data pin to lightly “hold” the last driven value on the data bus pins when the DSP or an external device is not actively driving the bus. Each bus keeper is built from a three-state driver with nominal 15 k Ω output resistance which is fed back to the input in a positive feedback configuration. The resistance isolated driver then pulls the output in one direction or the other keeping the last driven value. This circuit is enabled in all functional modes and is only disabled when $\overline{\text{SHZ}}$ is pulled low.

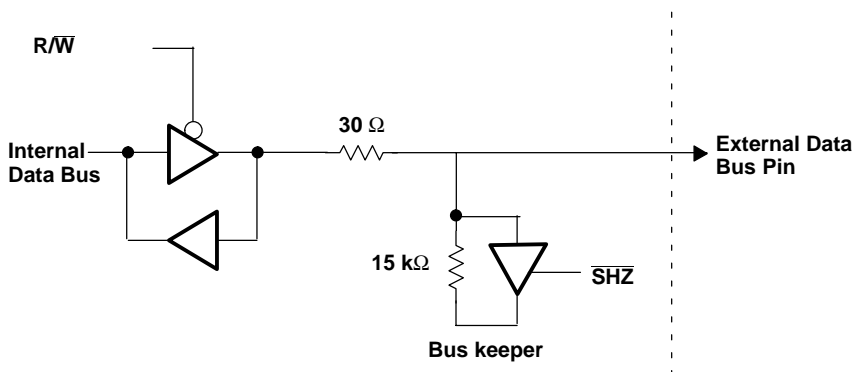

Figure 9. Bus Keeper Circuit

For an external device to change the state of these pins, it must be able to drive a small dc current until the driver threshold is crossed. At the crossover point, the driver changes state, agreeing with the external driver and assisting the change. The voltage threshold of the bus keeper is approximately at 50% of the DV_{DD} supply voltage. The typical output impedance of 30 Ω for all SM/SMJ320VC33 I/O pins is easily capable of meeting this requirement.

SM320VC33, SMJ320VC33 DIGITAL SIGNAL PROCESSOR

SGUS034E - FEBRUARY 2001 - REVISED OCTOBER 2002

bootloader operation

When $\overline{\text{MCBL}}/\overline{\text{MP}} = 1$, an internal ROM is decoded into the address range of 0x000000-0x000FFF. Therefore, when reset occurs, execution begins within the internal ROM program and vector space. No external activity will be evident until one of the boot options is enabled. These options are enabled by pulling an external interrupt pin low, which the boot-load software then detects, causing a particular routine to be executed (see Table 6).

Table 6. INT0 - INT3 Sources

ACTIVE INTERRUPT	ADDRESS/SOURCE WHERE BOOT DATA IS READ FROM	DATA FORMAT
INT0	0x001000	8, 16, or 32-bit width
INT1	0x400000	8, 16, or 32-bit width
INT2	0xFFFF00	8, 16, or 32-bit width
INT3	Serial Port	32-bit, external clock, and frame synch

When $\overline{\text{MCBL}}/\overline{\text{MP}} = 1$, the reset and interrupt vectors are hard-coded within the internal ROM. Since this is a read-only device, these vectors cannot be modified. To enable user-defined interrupt routines, the internal vectors contain fixed values that point to an internal section of SRAM beginning at 0x809FC1. Code execution begins at these locations so it is important to place branch instructions (to the interrupt routine) at these locations and not vectors.

The bootloader program requires a small stack space for calls and returns. Two SRAM locations at 0x809800 and 0x809801 are used for this stack. Data should not be boot loaded into these locations as this will corrupt the bootloader program run-time stack. After the boot-load operation is complete, a program can reclaim these locations. The simplest solution is to begin a program stack or uninitialized data section at 0x809800.

For additional detail on bootloader operation including the bootloader source code, see the *TMS320C3x User's Guide* (literature number SPRU031).

A bit I/O line or external logic can be used to safely disable the MCBL mode after bootloading is complete. However, to ensure proper operation, the CPU should not be currently executing code or using external data as the change takes place. In the following example, the XF0 pin is 3-state on reset, which allows the pullup resistor to place the DSP in MCBL mode. The following code, placed at the beginning of an application then causes the XF0 pin to become an active-logic-low output, changing the DSP mode to MP. The cache-enable and RPTS instructions are used since they cause the LDI instruction to be executed multiple times even though it has been fetched only once (before the mode change). In other words, the RPTS instruction acts as a one-level-deep program cache for externally executed code. If the application code is to be executed from internal RAM, no special provisions are needed.

```
LDI    8000h,ST ; Enable the cache
RPTS   4        ; RPTS will fetch the following opcode 1 time
LDI    2h, IOF  ; Drive MCBL/MP=0 for several cycles allowing
                ; the pipeline to clear
```

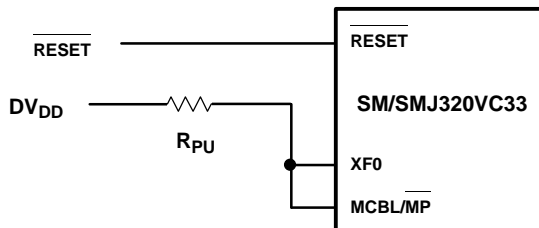

Figure 10. Changing Bootload Select Pin



JTAG emulation

Though the 320VC33 contains a JTAG debug port which allows multiple JTAG enabled chips to be daisy-chained, boundary scan of the pins is not supported. If the pin scan path is selected, it will be routed through a null register with a length of one. For additional information concerning the emulation interface, see *JTAG/MPSD Emulation Technical Reference* (literature number SPDU079).

designing a target system emulator connector (14-pin header)

JTAG target devices support emulation through a dedicated emulation port. This port is a superset of the test access port standard and is accessed by the emulator. To communicate with the emulator, **the target system must have a 14-pin header** (two rows of seven pins) with the connections that are shown in Figure 11. Table 7 describes the emulation signals.

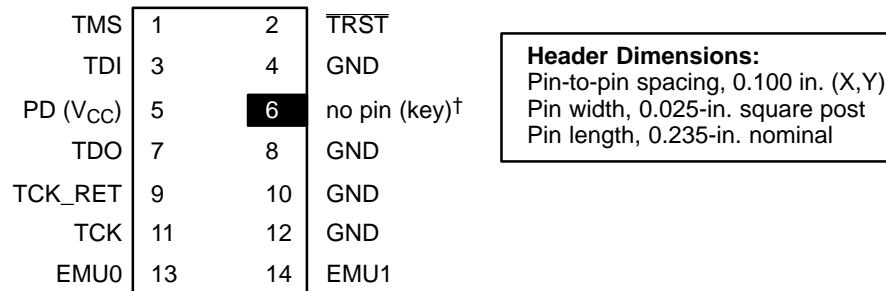

[†] While the corresponding female position on the cable connector is plugged to prevent improper connection, the cable lead for pin 6 is present in the cable and is grounded, as shown in the schematics and wiring diagrams in this document.

Figure 11. 14-Pin Header Signals and Header Dimensions

Table 7. 14-Pin Header Signal Descriptions

SIGNAL	DESCRIPTION	EMULATOR [†] STATE	TARGET [†] STATE
TMS [‡]	Test mode select	O	I
TDI	Test data input	O	I
TDO	Test data output	I	O
TCK	Test clock. TCK is a 10.368-MHz clock source from the emulation cable pod. This signal can be used to drive the system test clock	O	I
$\overline{\text{TRST}}^{\S}$	Test reset	O	I
EMU0 [¶]	Emulation pin 0	I	I/O
EMU1 [¶]	Emulation pin 1	I	I/O
PD(V _{CC})	Presence detect. Indicates that the emulation cable is connected and that the target is powered up. PD should be tied to V _{CC} in the target system.	I	O
TCK_RET	Test clock return. Test clock input to the emulator. May be a buffered or unbuffered version of TCK.	I	O
GND	Ground		

[†] I = input; O = output

[‡] Use 1-50K pullups for TMS, EMU0 and EMU1.

[§] Use 1-50K pulldown for TRST. Do not use pullup resistors on $\overline{\text{TRST}}$: it has an internal pulldown device. In a low-noise environment, $\overline{\text{TRST}}$ can be left floating. In a high-noise environment, an additional pulldown resistor may be needed. (The size of this resistor should be based on electrical current considerations.)

[¶] EMU0 and EMU1 are I/O drivers configured as open-drain (open-collector) drivers. They are used as bidirectional signals for emulation global start and stop.

SM320VC33, SMJ320VC33 DIGITAL SIGNAL PROCESSOR

SGUS034E - FEBRUARY 2001 - REVISED OCTOBER 2002

designing a target system emulator connector (14-pin header) (continued)

Although other headers can be used, recommended parts include:

straight header, unshrouded

DuPont Connector Systems
part numbers: 65610-114
65611-1 14
67996-114
67997-114

JTAG emulator cable pod logic

Figure 12 shows a portion of the emulator cable pod. The functional features of the pod are as follows:

- Signals TDO and TCK_RET can be parallel-terminated inside the pod if required by the application. By default, these signals are not terminated.
- Signal TCK is driven with a 74LVT240 device. Because of the high-current drive (32 mA I_{OL}/I_{OH}), this signal can be parallel-terminated. If TCK is tied to TCK_RET, the parallel terminator in the pod can be used.
- Signals TMS and TDI can be generated from the falling edge of TCK_RET, according to the bus slave device timing rules.
- Signals TMS and TDI are series-terminated to reduce signal reflections.
- A 10.368-MHz test clock source is provided. Another test clock can be used for greater flexibility.

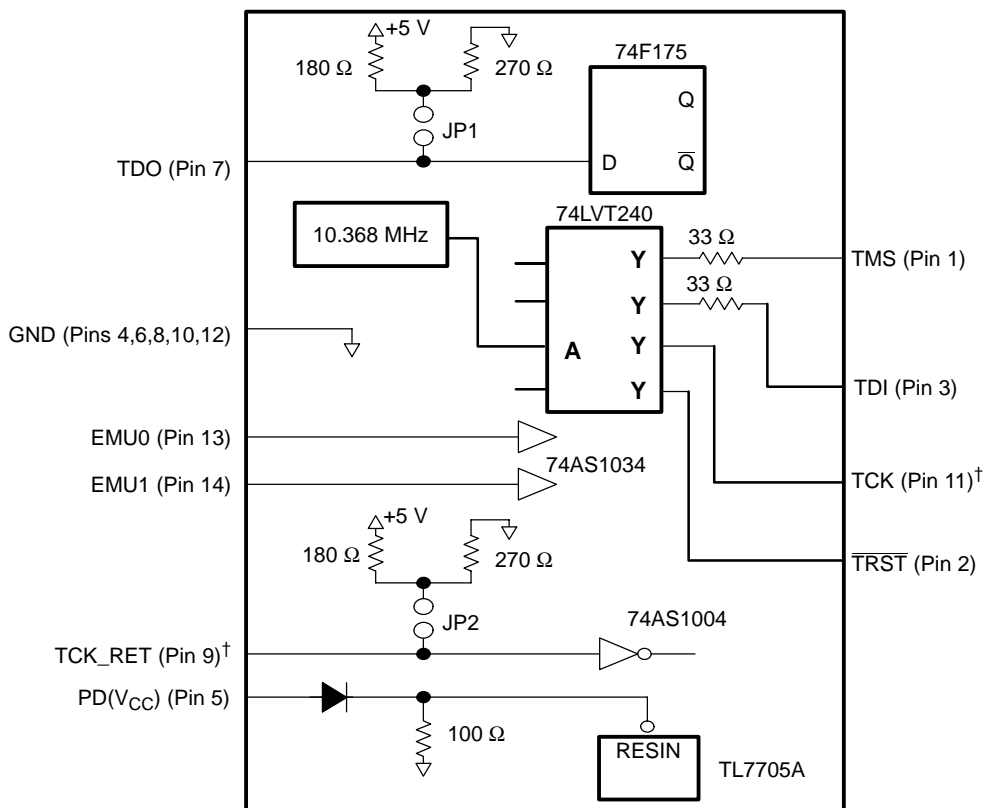

† The emulator pod uses TCK_RET as its clock source for internal synchronization. TCK is provided as an optional target system test clock source.

Figure 12. JTAG Emulator Cable Pod Interface

device and development support tool nomenclature

To designate the stages in the product development cycle, TI assigns prefixes to the part numbers of all TMS320™ DSP family devices and support tools. Each TMS320™ DSP member has one of three prefixes: TMX, TMP, or TMS. Texas Instruments recommends two of three possible prefix designators for its support tools: TMDX and TMDS. These prefixes represent evolutionary stages of product development from engineering prototypes (TMX/TMDX) through fully qualified production devices/tools (TMS/TMDS). This development flow is defined below.

Device development evolutionary flow:

- SMX** Experimental device that is not necessarily representative of the final device's electrical specifications
- TMP** Final silicon die that conforms to the device's electrical specifications but has not completed quality and reliability verification
- SM/SMJ** Fully-qualified production device

Support tool development evolutionary flow:

- TMDX** Development support product that has not yet completed Texas Instruments internal qualification testing.
- TMDS** Fully qualified development support product

TMX and TMP devices and TMDX development support tools are shipped against the following disclaimer:

"Developmental product is intended for internal evaluation purposes."

TMS devices and TMDS development support tools have been characterized fully, and the quality and reliability of the device has been demonstrated fully. TI's standard warranty applies.

Predictions show that prototype devices (TMX or TMP) have a greater failure rate than the standard production devices. Texas Instruments recommends that these devices not be used in any production system because their expected end-use failure rate still is undefined. Only qualified production devices are to be used.

TI device nomenclature also includes a suffix with the device family name. This suffix indicates the package type (for example, HFG, GNM, or GNL) and temperature range (for example, M). Figure 13 provides a legend for reading the complete device name for any TMS320™ DSP family member.

SM320VC33, SMJ320VC33 DIGITAL SIGNAL PROCESSOR

SGUS034E - FEBRUARY 2001 - REVISED OCTOBER 2002

device and development support tool nomenclature (continued)

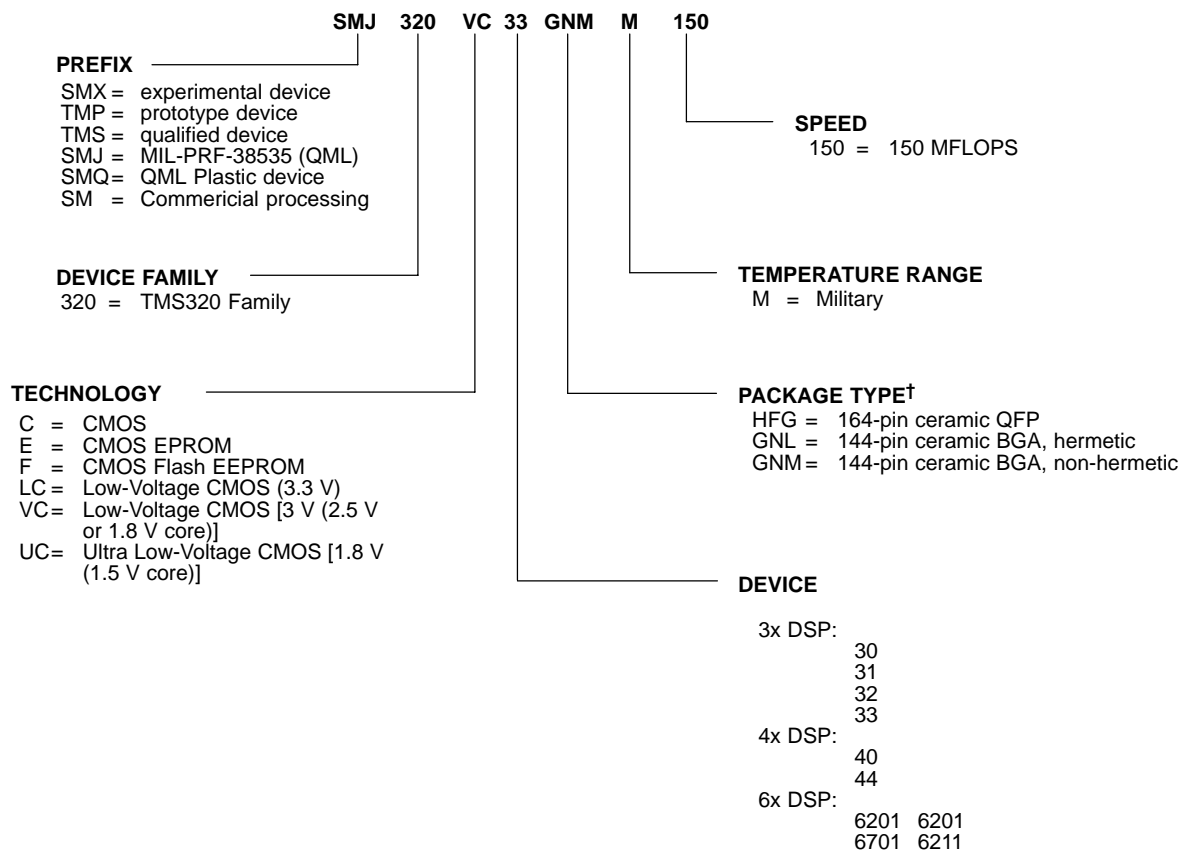

† QFP = Quad Flat Package
 LQFP = Low-Profile Quad Flat Package
 BGA = Ball Grid Array

Figure 13. TMS320™ DSP Device Nomenclature

absolute maximum ratings over specified temperature range (unless otherwise noted)†

Supply voltage range, DV_{DD}^\ddagger	- 0.3 V to 4 V
Supply voltage range, CV_{DD}^\ddagger	- 0.3 V to 2.4 V
Input voltage range, V_I^\S	- 1 V to 4.6 V
Output voltage range, V_O	- 0.3 V to 4.6 V
Continuous power dissipation (worst case)¶	500 mW
Operating case temperature range, T_C	-55 °C to 125 °C
Storage temperature range, T_{stg}	- 55 °C to 150 °C

† Stresses beyond those listed under “absolute maximum ratings” may cause permanent damage to the device. These are stress ratings only, and functional operation of the device at these or any other conditions beyond those indicated under “recommended operating conditions” is not implied. Exposure to absolute-maximum-rated conditions for extended periods may affect device reliability.

‡ All voltage values are with respect to V_{SS} .

§ Absolute dc input level should not exceed the DV_{DD} or V_{SS} supply rails by more than 0.3 V. An instantaneous low current pulse of < 2 ns, < 10 mA, and < 1 V amplitude is permissible.

¶ Actual operating power is much lower. This value was obtained under specially produced worst-case test conditions for the SM/SMJ320VC33, which are not sustained during normal device operation. These conditions consist of continuous parallel writes of a checkerboard pattern to the external data and address buses at the maximum possible rate with a capacitive load of 30 pF. See normal (I_{CC}) current specification in the electrical characteristics table and also read *TMS320C3x General-Purpose Applications* (literature number SPRU194).

recommended operating conditions‡#||

	MIN	NOM	MAX	UNIT
CV_{DD} Supply voltage for the core CPU [☆]	1.71	1.8	1.89	V
DV_{DD} Supply voltage for the I/O pins [□]	3.14	3.3	3.46	V
V_{SS} Supply ground		0		V
V_{IH} High-level input voltage	$0.7 \times DV_{DD}$		$DV_{DD} + 0.3^\S$	V
V_{IL} Low-level input voltage	-0.3^\S		$0.3 \times DV_{DD}$	V
I_{OH} High-level output current			4	mA
I_{OL} Low-level output current			4	mA
T_C Operating case temperature	-55		125	°C
C_L Capacitive load per output pin			30	pF

‡ All voltage values are with respect to V_{SS} .

§ Absolute dc input level should not exceed the DV_{DD} or V_{SS} supply rails by more than 0.3 V. An instantaneous low current pulse of < 2 ns, < 10 mA, and < 1 V amplitude is permissible.

All inputs and I/O pins are configured as inputs.

|| All input and I/O pins use a Schmidt hysteresis inputs except \overline{SHZ} and D0-D31. Hysteresis is approximately 10% of DV_{DD} and is centered at $0.5 \times DV_{DD}$.

☆ CV_{DD} should not exceed DV_{DD} by more than 0.7 V. (Use a Schottky clamp diode between these supplies.)

□ DV_{DD} should not exceed CV_{DD} by more than 2.5 V.



SM320VC33, SMJ320VC33 DIGITAL SIGNAL PROCESSOR

SGUS034E - FEBRUARY 2001 - REVISED OCTOBER 2002

electrical characteristics over recommended ranges of supply voltage (unless otherwise noted)†

PARAMETER		TEST CONDITIONS‡	MIN	TYP§	MAX	UNIT
V _{OH}	High-level output voltage	DV _{DD} = MIN, I _{OH} = MAX	2.4			V
V _{OL}	Low-level output voltage	DV _{DD} = MIN, I _{OL} = MAX			0.4	V
I _Z	High-impedance current	T _C = 25°C, DV _{DD} = MAX	-5		+5	μA
I _I	Input current	T _C = 25°C, V _I = V _{SS} to DV _{DD}	-5		+5	μA
I _{IPU}	Input current (with internal pullup)	Inputs with internal pullups¶	-600		10	μA
I _{IPD}	Input current (with internal pulldown)	Inputs with internal pulldowns¶	600		-10	μA
I _{BKU}	Input current (with bus keeper) pullup#	Bus keeper opposes until conditions match	-600		10	μA
I _{BKD}	Input current (with bus keeper) pulldown#		600		-10	μA
I _{DDD}	Supply current, pins ★	T _C = 25°C, f _x = 75 MHz DV _{DD} = MAX		25	260	mA
I _{DDC}	Supply current, core CPU ★	T _C = 25°C, f _x = 75 MHz CV _{DD} = MAX		60	215	mA
I _{DD}	IDLE2, Supply current, I _{DDD} plus I _{DDC}	PLL enabled, oscillator enabled		2		mA
		PLL disabled, oscillator enabled		500		μA
		PLL disabled, oscillator disabled, FCLK = 0		50		
C _i	Input capacitance	All inputs except XIN			10*	pF
		XIN			10*	
C _o	Output capacitance				10*	pF

* Not production tested

† All voltage values are with respect to V_{SS}.

‡ For test conditions shown as MIN, MAX, or NOM, use the appropriate value specified in the recommended operating conditions table.

§ For VC33, all typical values are at DV_{DD} = 3.3, CV_{DD} = 1.8 V, T_C (case temperature) = 25°C.

¶ Pins with internal pullup devices: TDI, TCK, and TMS. Pin with internal pulldown device: TRST.

Pins D0-D31 include internal bus keepers that maintain valid logic levels when the bus is not driven (see Figure 9).

|| Actual operating current is less than this maximum value. This value was obtained under specially produced worst-case test conditions, which are not sustained during normal device operation. These conditions consist of continuous parallel writes of a checkerboard pattern at the maximum rate possible. See *TMS320C3x General-Purpose Applications* (literature number SPRU194).

★f_x is the PLL output clock frequency.

PARAMETER MEASUREMENT INFORMATION

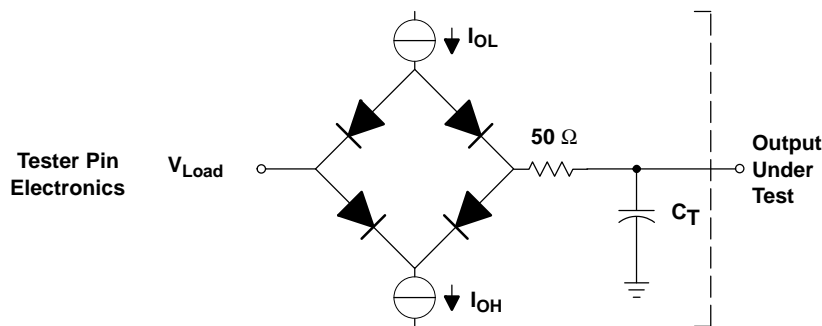

Where: I_{OL} = 4 mA (all outputs) for dc levels test.
I_O and I_{OH} are adjusted during ac timing analysis to achieve an ac termination of 50 Ω
V_{LOAD} = DV_{DD}/2
C_T = 40-pF typical load-circuit capacitance

Figure 14. Test Load Circuit

PARAMETER MEASUREMENT INFORMATION

timing parameter symbology

Timing parameter symbols used herein were created in accordance with JEDEC Standard 100. To shorten the symbols, some of the pin names and other related terminology have been abbreviated as follows, unless otherwise noted:

Lowercase subscripts and their meanings

a	access time
c	cycle time (period)
d	delay time
dis	disable time
en	enable time
f	fall time
h	hold time
r	rise time
su	setup time
t	transition time
v	valid time
w	pulse duration (width)
x	unknown, changing, or don't care level

Letters and symbols and their meanings

H	High
L	Low
V	Valid
Z	High Impedance

Additional symbols and their meaning

A	Address lines (A23- A0)	H	H1 and H3
ASYNCH	Asynchronous reset signals (XF0, XF1, CLKX0, DX0, FSX0, CLKR0, DR0, FSR0, TCLK0, and TCLK1)	HOLD	$\overline{\text{HOLD}}$
CLKX	CLKX0	HOLDA	$\overline{\text{HOLDA}}$
CLKR	CLKR0	IACK	$\overline{\text{IACK}}$
CONTROL	Control signals	INT	$\overline{\text{INT3- INT0}}$
D	Data lines (D31- D0)	PAGE	$\overline{\text{PAGE0- PAGE3}}$
DR	DR	RDY	$\overline{\text{RDY}}$
DX	DX	RW	$\overline{\text{R/W}}$
EXTCLK	EXTCLK	RW	$\overline{\text{R/W}}$
FS	FSX/R	RESET	$\overline{\text{RESET}}$
FSX	FSX0	S	$\overline{\text{STRB}}$
FSR	FSR0	SCK	CLKX/R
GPI	General-purpose input	SHZ	$\overline{\text{SHZ}}$
GPIO	General-purpose input/output; peripheral pin (CLKX0, CLKR0, DX0, DR0, FSX0, FSR0, TCLK0, and TCLK1)	TCLK	TCLK0, TCLK1, or TCLKx
GPO	General-purpose output	XF	XF0, XF1, or XFx
H1	H1	XF0	XF0
H3	H3	XF1	XF1
		XIN	XIN

SM320VC33, SMJ320VC33 DIGITAL SIGNAL PROCESSOR

SGUS034E - FEBRUARY 2001 - REVISED OCTOBER 2002

phase-locked loop (PLL) circuit timing

phase-locked loop characteristics using EXTCLK or on-chip crystal oscillator†

PARAMETER		MIN	MAX	UNIT
F _{pllin}	Frequency range, PLL input	5*	15*	MHz
F _{plout}	Frequency range, PLL output	25*	75*	MHz
I _{pll}	PLL current, CV _{DD} supply		2*	mA
P _{pll}	PLL power, CV _{DD} supply		5*	mW
PLL _{dc}	PLL output duty cycle at H1	45*	55*	%
PLLJ	PLL output jitter, F _{plout} = 25 MHz		400*	ps
PLL _{LOCK}	PLL lock time in input cycles		1000	cycles

* Not production tested

† Duty cycle is defined as $100 \cdot t_1 / (t_1 + t_2) \%$

To ensure clean internal clock references, the minimal low and high pulse durations must be maintained. At high frequencies, this may require a fast rise and fall time as well as a tightly controlled duty cycle. At lower frequencies, these requirements are less restrictive when in x1 and x0.5 modes. The PLL, however, must have an input duty cycle of between 40% and 60% for proper operation.



clock circuit timing

The following table defines the timing parameters for the clock circuit signals.

circuit parameters for on-chip crystal oscillator† (see Figure 15)

PARAMETER	MIN	TYP	MAX	UNIT
V_O	Oscillator internal supply voltage			V
F_O	Fundamental mode frequency range			MHz
V_{bias}	DC bias point (input threshold)			% V_O
R_{fbk}	Feedback resistance			k Ω
R_{out}	Small signal ac output impedance			Ω
V_{xoutac}	The ac output voltage with test crystal‡			% V_O
V_{xinac}	The ac input voltage with test crystal‡			% V_O
V_{xoutl}	$V_{xin} = V_{xinh}$, $I_{xout} = 0$, $F_O=0$ (logic input)			V
V_{xouth}	$V_{xin} = V_{xinl}$, $I_{xout} = 0$, $F_O=0$ (logic input)			V
V_{inl}	When used for logic level input, oscillator enabled			V
V_{inh}	When used for logic level input, oscillator enabled			V
V_{xinh}	When used for logic level input, oscillator disabled			V
C_{xout}	XOUT internal load capacitance			pF
C_{xin}	XIN internal load capacitance			pF
$t_{d(XIN-H1)}$	Delay time, XIN to H1 x1 and x0.5 modes			ns
I_{inl}	Input current, feedback enabled, $V_{il} = 0$			μ A
I_{inh}	Input current, feedback enabled, $V_{il} = V_{ih}$			μ A

* Not production tested

† This circuit is intended for series resonant fundamental mode operation.

‡ Signal amplitude is dependent on the crystal and load used.

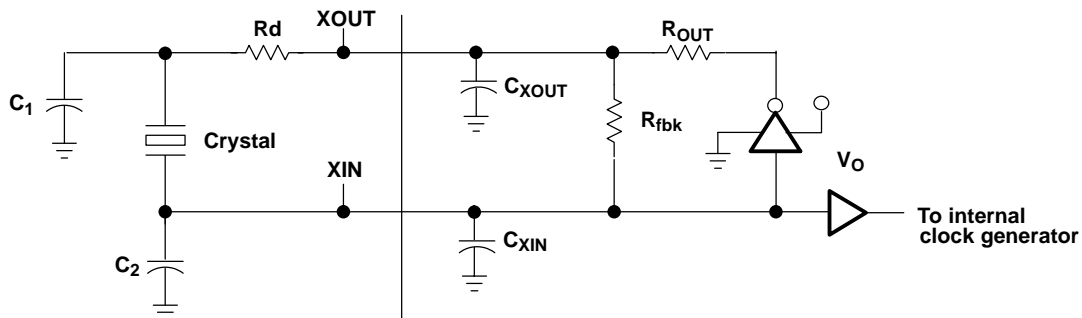

NOTE A: See Table 3 for value of Rd.

Figure 15. On-Chip Oscillator Circuit

SM320VC33, SMJ320VC33 DIGITAL SIGNAL PROCESSOR

SGUS034E - FEBRUARY 2001 - REVISED OCTOBER 2002

clock circuit timing (continued)

The following tables define the timing requirements and switching characteristics for EXTCLK.

timing requirements for EXTCLK, all modes (see Figure 16 and Figure 17)

		MIN	MAX	UNIT	
$t_{r(EXTCLK)}$	Rise time, EXTCLK	$F = F_{max}$, x0.5 and x1 modes	1*	ns	
		$F < F_{max}$	4*		
$t_{f(EXTCLK)}$	Fall time, EXTCLK	$F = F_{max}$, x0.5 and x1 modes	1*	ns	
		$F < F_{max}$	4*		
$t_{w(EXTCLKL)}$	Pulse duration, EXTCLK low	x5 mode	21*	ns	
		x1 mode	6*		
		x0.5 mode	4*		
$t_{w(EXTCLKH)}$	Pulse duration, EXTCLK high	x5 mode	21*	ns	
		x1 mode	5*		
		x0.5 mode	4*		
$t_{dc(EXTCLK)}$	Duty cycle, EXTCLK [$t_{w(EXTCLKH)} / t_{c(H)}$]	x5 PLL mode	40*	60*	%
		x1 and x0.5 modes, $F = \max$	45	55	
		x1 and x0.5 modes, $F = 0$ Hz	0*	100*	
$t_{c(EXTCLK)}$	Cycle time, EXTCLK	x5 mode	66.7*	200*	ns
		x1 mode	13.3		
		x0.5 mode	10*		
F_{ext}	Frequency range, $1/t_{c(EXTCLK)}$	x5 mode	5*	15*	MHz
		x1 mode	0	75	
		x0.5 mode	0*	100*	

* Not production tested

switching characteristics for EXTCLK over recommended operating conditions, all modes (see Figure 16 and Figure 17)

PARAMETER		MIN	TYP	MAX	UNIT	
V_{mid}	Mid-level, used to measure duty cycle		$0.5 \times DV_{DD}$		V	
$t_{d(EXTCLK-H)}$	Delay time, EXTCLK to H1 and H3	x1 mode	2*	4.5	7*	ns
		x0.5 mode	2*	4.5	7*	
$t_{r(H)}$	Rise time, H1 and H3			3*	ns	
$t_{f(H)}$	Fall time, H1 and H3			3*	ns	
$t_{d(HL-HH)}$	Delay time, from H1 low to H3 high or from H3 low to H1 high	-1.5*		2*	ns	
$t_{c(H)}$	Cycle time, H1 and H3	x5 PLL mode		$1/(5 \times f_{ext})$	ns	
		x1 mode		$1/f_{ext}$		
		x0.5 mode		$2/f_{ext}$		

* Not production tested



clock circuit timing (continued)

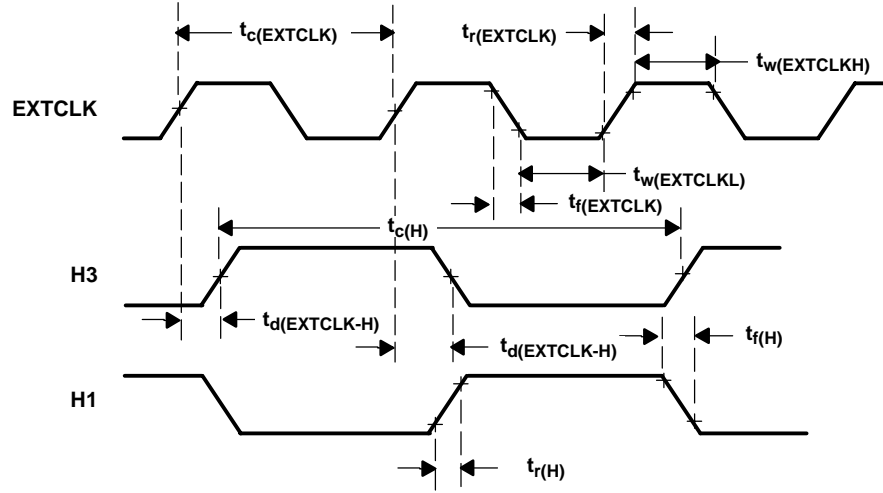
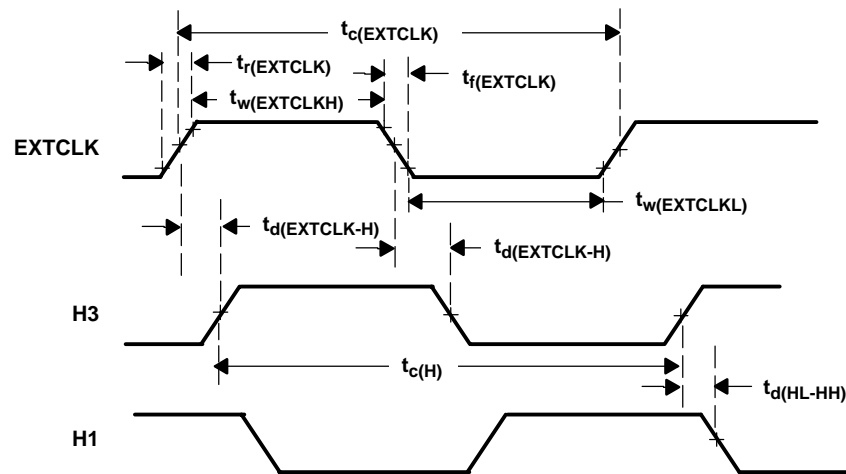

Figure 16. Divide-By-Two Mode



NOTE A: EXTCLK is held low.

Figure 17. Divide-By-One Mode

SM320VC33, SMJ320VC33 DIGITAL SIGNAL PROCESSOR

SGUS034E - FEBRUARY 2001 - REVISED OCTOBER 2002

memory read/write timing

The following tables define memory read/write timing parameters for $\overline{\text{STRB}}$.

timing requirements for memory read/write† (see Figure 18, Figure 19, and Figure 20)

		MIN	MAX	UNIT
$t_{\text{su}}(\text{D-H1L})\text{R}$	Setup time, Data before H1 low (read)	5*		ns
$t_{\text{h}}(\text{H1L-D})\text{R}$	Hold time, Data after H1 low (read)	-1*		ns
$t_{\text{su}}(\text{RDY-H1H})$	Setup time, $\overline{\text{RDY}}$ before H1 high	5		ns
$t_{\text{h}}(\text{H1H-RDY})$	Hold time, $\overline{\text{RDY}}$ after H1 high	-1*		ns
$t_{\text{d}}(\text{A-RDY})$	Delay time, Address valid to $\overline{\text{RDY}}$		P - 6*‡	ns
$t_{\text{v}}(\text{A-D})$	Valid time, Data valid after address PAGE _x , or $\overline{\text{STRB}}$ valid	0 wait state, $C_{\text{L}} = 30 \text{ pF}$	6*	ns
		1 wait state	$t_{\text{c}}(\text{H}) + 6^*$	ns

* Not production tested

† These timings assume a similar loading of 30 pF on all pins.

‡ P = $t_{\text{c}}(\text{H})/2$ (when duty cycle equals 50%).

switching characteristics over recommended operating conditions for memory read/write† (see Figure 18, Figure 19, and Figure 20)

PARAMETER		MIN	MAX	UNIT
$t_{\text{d}}(\text{H1L-SL})$	Delay time, H1 low to $\overline{\text{STRB}}$ low	-1*	3	ns
$t_{\text{d}}(\text{H1L-SH})$	Delay time, H1 low to $\overline{\text{STRB}}$ high	-1*	3	ns
$t_{\text{d}}(\text{H1H-RWL})\text{W}$	Delay time, H1 high to $\overline{\text{R/W}}$ low (write)	-1*	3	ns
$t_{\text{d}}(\text{H1L-A})$	Delay time, H1 low to address valid	-1*	3	ns
$t_{\text{d}}(\text{H1H-RWH})\text{W}$	Delay time, H1 high to $\overline{\text{R/W}}$ high (write)	-1*	3	ns
$t_{\text{d}}(\text{H1H-A})\text{W}$	Delay time, H1 high to address valid on back-to-back write cycles (write)	-1*	3*	ns
$t_{\text{v}}(\text{H1L-D})\text{W}$	Valid time, Data after H1 low (write)		5	ns
$t_{\text{h}}(\text{H1H-D})\text{W}$	Hold time, Data after H1 high (write)	0*	5	ns

* Not production tested

† These timings assume a similar loading of 30 pF on all pins.

Output load characteristics for high-speed and low-speed (low-noise) output buffers are shown in Figure 18. High-speed buffers are used on A0 - A23, PAGE0 - PAGE3, H1, H3, $\overline{\text{STRB}}$, and $\overline{\text{R/W}}$. All other outputs use the low-speed, (low-noise) output buffer.

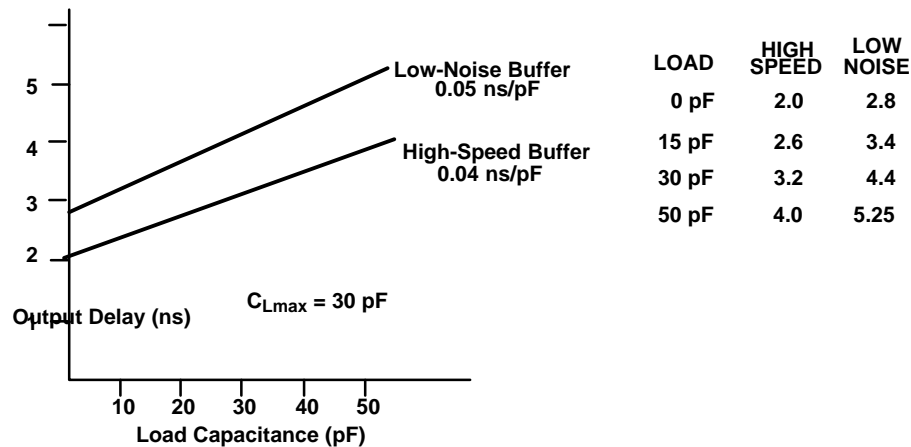
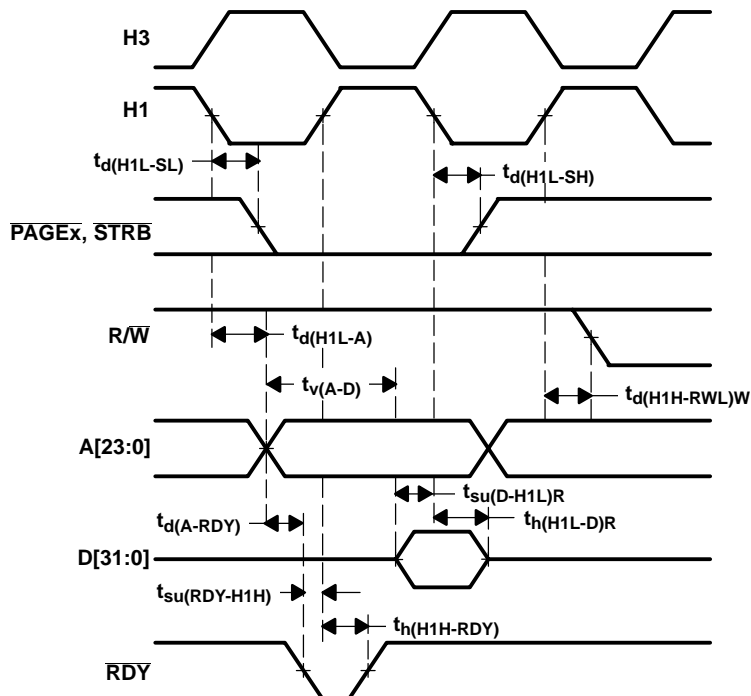

Figure 18. Output Load Characteristics, Buffer Only

memory read/write timing (continued)



NOTE A: $\overline{\text{STRB}}$ remains low during back-to-back read operations.

Figure 19. Timing for Memory ($\overline{\text{STRB}} = 0$ and $\overline{\text{PAGE}}_x = 0$) Read

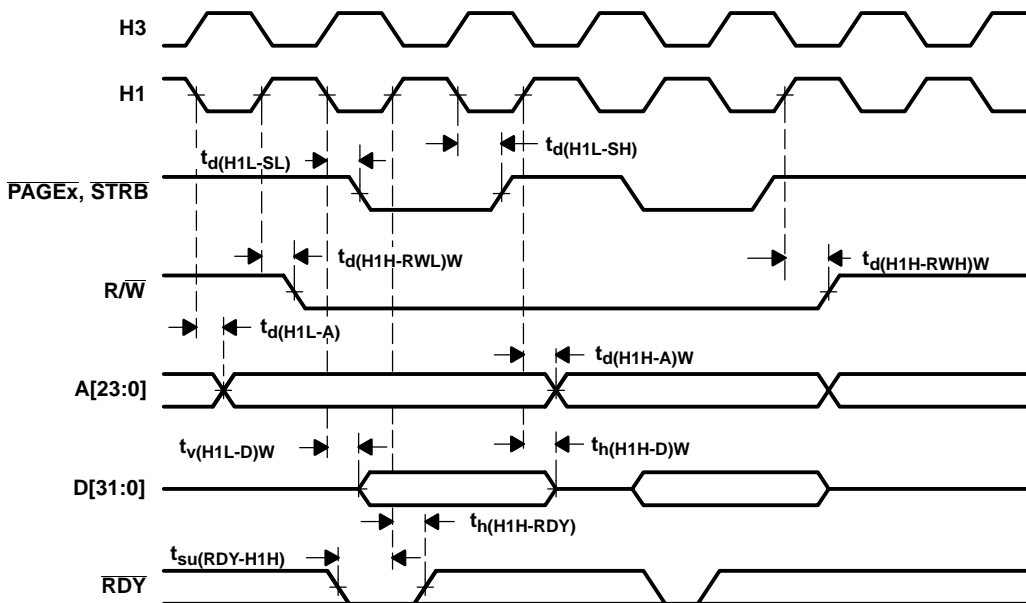

Figure 20. Timing for Memory ($\overline{\text{STRB}} = 0$ and $\overline{\text{PAGE}}_x = 0$) Write

SM320VC33, SMJ320VC33 DIGITAL SIGNAL PROCESSOR

SGUS034E - FEBRUARY 2001 - REVISED OCTOBER 2002

XF0 and XF1 timing when executing LDFI or LDII

The following tables define the timing parameters for XF0 and XF1 during execution of LDFI or LDII.

timing requirements for XF0 and XF1 when executing LDFI or LDII (see Figure 21)

		MIN	MAX	UNIT
$t_{su(XF1-H1L)}$	Setup time, XF1 before H1 low	4*		ns
$t_{h(H1L-XF1)}$	Hold time, XF1 after H1 low	0*		ns

* Not production tested

switching characteristics over recommended operating conditions for XF0 and XF1 when executing LDFI or LDII (see Figure 21)

PARAMETER	MIN	MAX	UNIT
$t_{d(H3H-XF0L)}$		3	ns

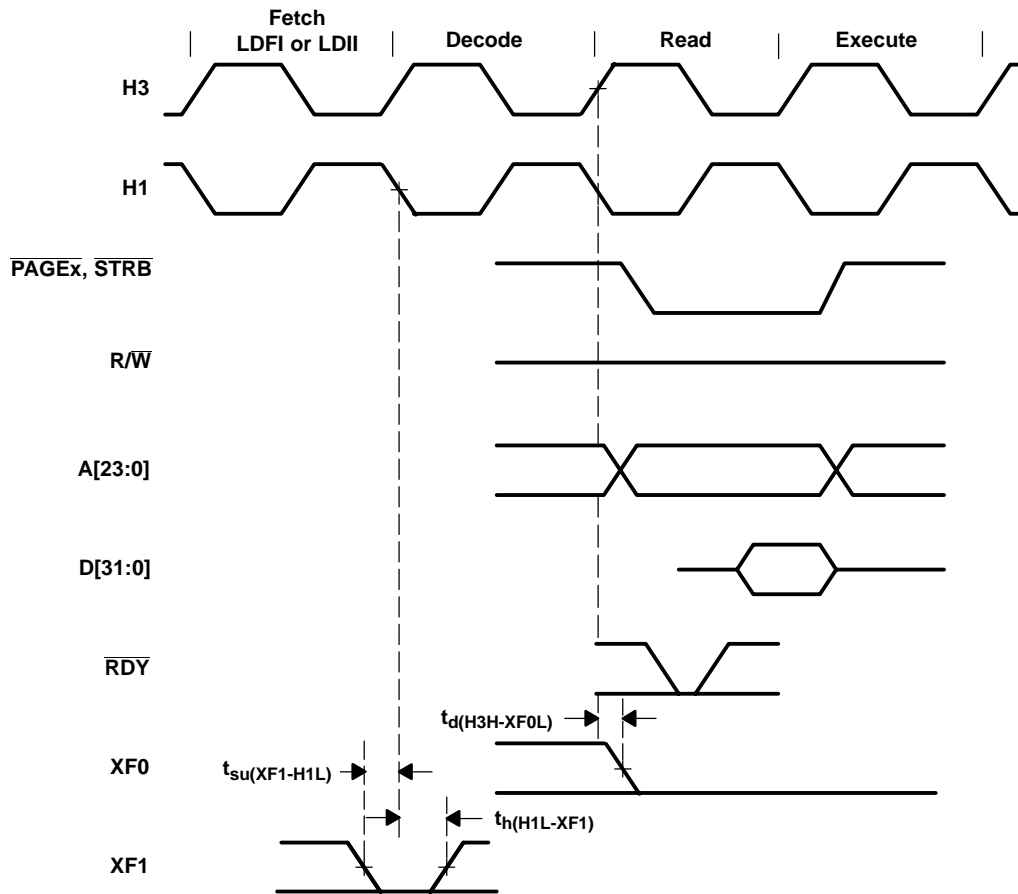

Figure 21. Timing for XF0 and XF1 When Executing LDFI or LDII

XF0 timing when executing STFI and STII†

The following table defines the timing parameters for the XF0 pin during execution of STFI or STII.

switching characteristics over recommended operating conditions for XF0 when executing STFI or STII (see Figure 22)

PARAMETER		MIN	MAX	UNIT
$t_{d(H3H-XF0H)}$	Delay time, H3 high to XF0 high†		3	ns

† XF0 is always set high at the beginning of the execute phase of the interlock-store instruction. When no pipeline conflicts occur, the address of the store is also driven at the beginning of the execute phase of the interlock-store instruction. However, if a pipeline conflict prevents the store from executing, the address of the store will not be driven until the store can execute.

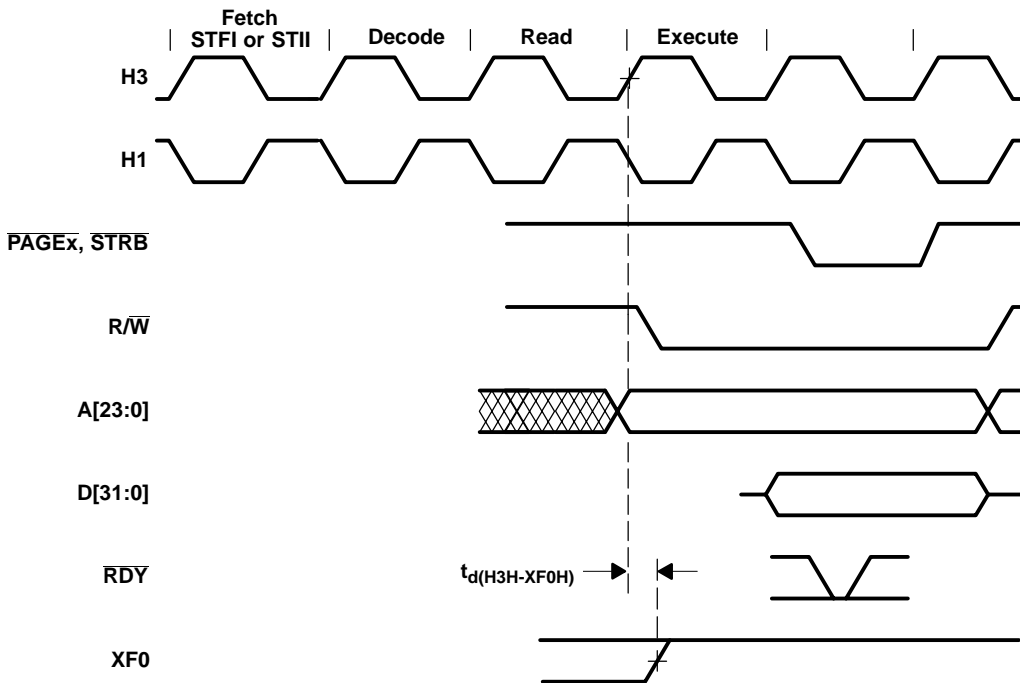

Figure 22. Timing for XF0 When Executing an STFI or STII

SM320VC33, SMJ320VC33 DIGITAL SIGNAL PROCESSOR

SGUS034E - FEBRUARY 2001 - REVISED OCTOBER 2002

XF0 and XF1 timing when executing SIGI

The following tables define the timing parameters for the XF0 and XF1 pins during execution of SIGI.

timing requirements for XF0 and XF1 when executing SIGI (see Figure 23)

		MIN	MAX	UNIT
$t_{su(XF1-H1L)}$	Setup time, XF1 before H1 low	4*		ns
$t_{h(H1L-XF1)}$	Hold time, XF1 after H1 low	0*		ns

* Not production tested

switching characteristics over recommended operating conditions for XF0 and XF1 when executing SIGI (see Figure 23)

PARAMETER	MIN	MAX	UNIT
$t_{d(H3H-XF0L)}$		3	ns
$t_{d(H3H-XF0H)}$		3	ns

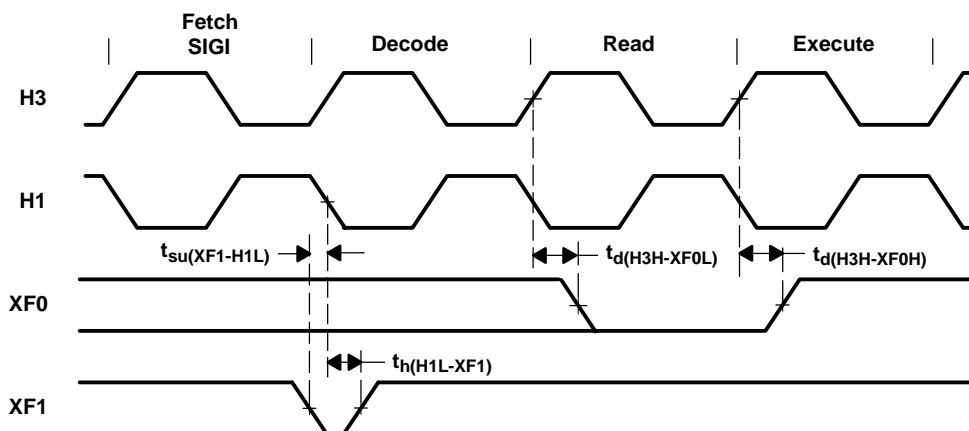

Figure 23. Timing for XF0 and XF1 When Executing SIGI

loading when XF is configured as an output

The following table defines the timing parameter for loading the XF register when the XF_x pin is configured as an output.

switching characteristics over recommended operating conditions for loading the XF register when configured as an output pin (see Figure 24)

PARAMETER		MIN	MAX	UNIT
$t_{v(H3H-XF)}$	Valid time, XF _x after H3 high		3	ns

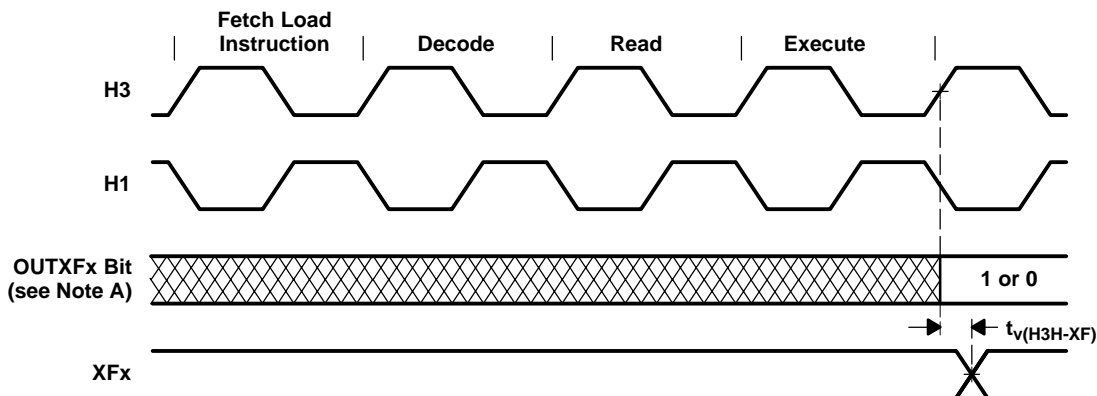

NOTE A: OUTXF_x represents either bit 2 or 6 of the IOF register.

Figure 24. Timing for Loading XF Register When Configured as an Output Pin

SM320VC33, SMJ320VC33 DIGITAL SIGNAL PROCESSOR

SGUS034E - FEBRUARY 2001 - REVISED OCTOBER 2002

changing XFx from an output to an input

The following table defines the timing parameters for changing the XFx pin from an output pin to an input pin.

timing requirements for changing XFx from output to input mode (see Figure 25)

		MIN	MAX	UNIT
$t_{su}(XF-H1L)$	Setup time, XFx before H1 low	4		ns
$t_h(H1L-XF)$	Hold time, XFx after H1 low	0		ns

switching characteristics over recommended operating conditions for changing XFx from output to input mode (see Figure 25)

PARAMETER	MIN	MAX	UNIT
$t_{dis}(H3H-XF)$		5*	ns

* Not production tested

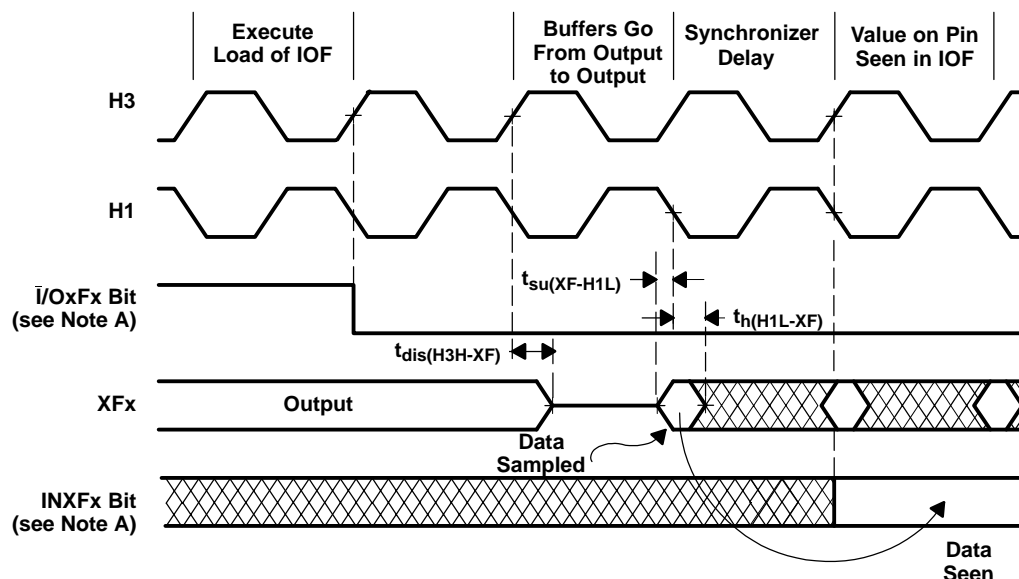

NOTE A: $\bar{I}/OxFx$ represents either bit 1 or bit 5 of the IOF register, and $INxFx$ represents either bit 3 or bit 7 of the IOF register.

Figure 25. Timing for Changing XFx From Output to Input Mode

changing XFx from an input to an output

The following table defines the timing parameter for changing the XFx pin from an input pin to an output pin.

switching characteristics over recommended operating conditions for changing XFx from input to output mode (see Figure 26)

PARAMETER		MIN	MAX	UNIT
$t_{d(H3H-XF)}$	Delay time, H3 high to XFx switching from input to output		3	ns

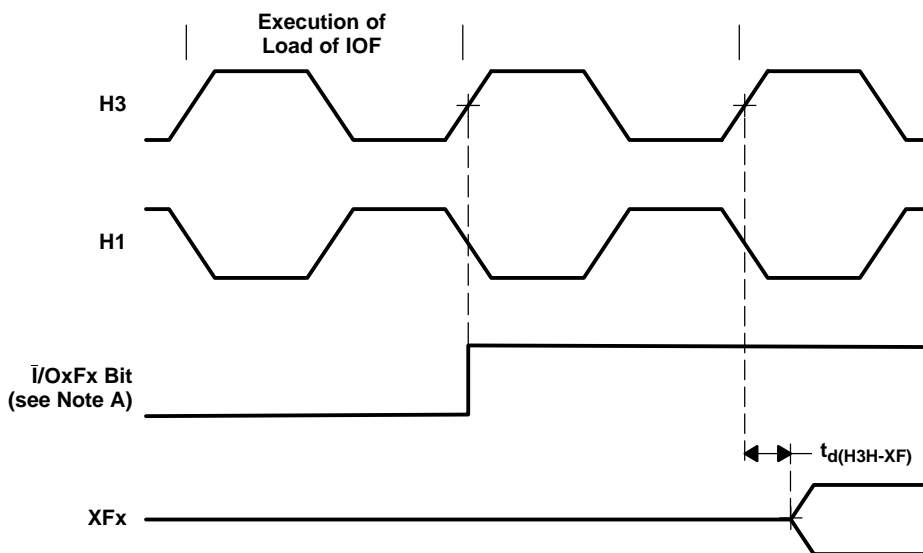

NOTE A: $\bar{I}/OxFx$ represents either bit 1 or bit 5 of the IOF register.

Figure 26. Timing for Changing XFx From Input to Output Mode

SM320VC33, SMJ320VC33 DIGITAL SIGNAL PROCESSOR

SGUS034E - FEBRUARY 2001 - REVISED OCTOBER 2002

reset timing

$\overline{\text{RESET}}$ is an asynchronous input that can be asserted at any time during a clock cycle. If the specified timings are met, the exact sequence shown in Figure 27 occurs; otherwise, an additional delay of one clock cycle is possible.

The asynchronous reset signals include XF0/1, CLKX0, DX0, FSX0, CLKR0, DR0, FSR0, and TCLK0/1.

Resetting the device initializes the bus control register to seven software wait states and therefore results in slow external accesses until these registers are initialized.

$\overline{\text{HOLD}}$ is a synchronous input that can be asserted during reset. It can take nine CPU cycles before $\overline{\text{HOLDA}}$ is granted.

The following table defines the timing parameters for the $\overline{\text{RESET}}$ signal. The numbers shown in Figure 27 correspond with those in the NO. column of the following table.

timing requirements for $\overline{\text{RESET}}$ (see Figure 27)

		MIN	MAX	UNIT
$t_{\text{su}}(\overline{\text{RESET}}\text{-EXTCLKL})$	Setup time, $\overline{\text{RESET}}$ before EXTCLK low	5*	P - 7*†	ns
$t_{\text{su}}(\overline{\text{RESET}}\text{-H1L})$	Setup time, $\overline{\text{RESET}}$ high before H1 low and after ten H1 clock cycles	5		ns

* Not production tested

† P = $t_{\text{c}}(\text{EXTCLK})$

switching characteristics over recommended operating conditions for $\overline{\text{RESET}}$ (see Figure 27)

PARAMETER		MIN*	MAX*	UNIT
$t_{\text{d}}(\text{EXTCLKH-H1H})$	Delay time, EXTCLK high to H1 high	2	7	ns
$t_{\text{d}}(\text{EXTCLKH-H1L})$	Delay time, EXTCLK high to H1 low	2	7	ns
$t_{\text{d}}(\text{EXTCLKH-H3L})$	Delay time, EXTCLK high to H3 low	2	7	ns
$t_{\text{d}}(\text{EXTCLKH-H3H})$	Delay time, EXTCLK high to H3 high	2	7	ns
$t_{\text{dis}}(\text{H1H-DZ})$	Disable time, Data (high impedance) from H1 high‡		6	ns
$t_{\text{dis}}(\text{H3H-AZ})$	Disable time, Address (high impedance) from H3 high		6	ns
$t_{\text{d}}(\text{H3H-CONTROLH})$	Delay time, H3 high to control signals high		3	ns
$t_{\text{d}}(\text{H1H-RWH})$	Delay time, H1 high to R/W high		3	ns
$t_{\text{d}}(\text{H1H-IACKH})$	Delay time, H1 high to $\overline{\text{TACK}}$ high		3	ns
$t_{\text{dis}}(\overline{\text{RESET}}\text{-ASYNCH})$	Disable time, Asynchronous reset signals disabled (high impedance) from $\overline{\text{RESET}}$ low§		6	ns

* Not production tested

‡ High impedance for Dbus is limited to nominal bus keeper $Z_{\text{OUT}} = 15 \text{ k}\Omega$.

§ Asynchronous reset signals include XF0/1, CLKX0, DX0, FSX0, CLKR0, DR0, FSR0, and TCLK0/1.



reset timing (continued)

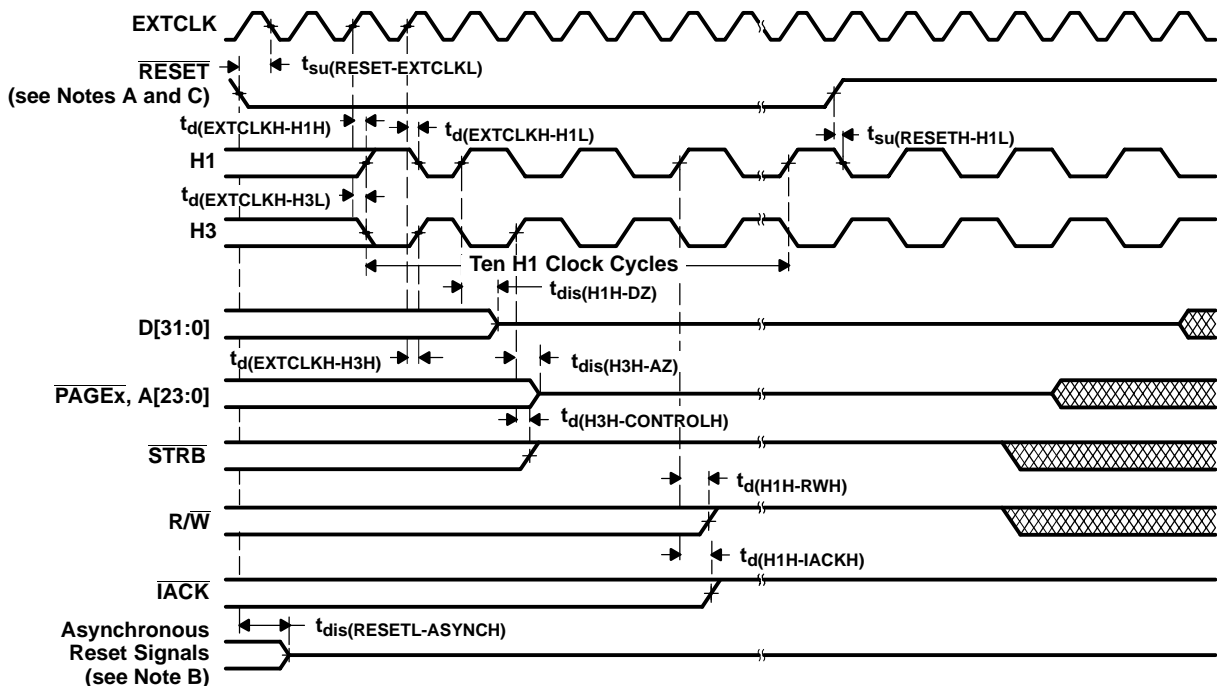

- NOTES:
- A. Clock circuit is configured in C31-compatible divide-by-2 mode. If configured for x1 mode, EXTCLK directly drives H3.
 - B. Asynchronous reset signals include XF0/1, CLKX0, DX0, FSX0, CLKR0, DR0, FSR0, and TCLK0/1.
 - C. $\overline{\text{RESET}}$ is a synchronous input that can be asserted at any point during a clock cycle. If the specified timings are met, the exact sequence shown occurs; otherwise, an additional delay of one clock cycle is possible.
 - D. In microprocessor mode, the reset vector is fetched twice, with seven software wait states each time. In microcomputer mode, the reset vector is fetched twice, with no software wait states.
 - E. The address and PAGE3-PAGE0 outputs are placed in a high-impedance state during reset requiring a nominal 10-22 k Ω pullup. If not, undesirable spurious reads can occur when these outputs are not driven.

Figure 27. RESET Timing

SM320VC33, SMJ320VC33 DIGITAL SIGNAL PROCESSOR

SGUS034E - FEBRUARY 2001 - REVISED OCTOBER 2002

interrupt response timing

The following table defines the timing parameters for the $\overline{\text{INTx}}$ signals.

timing requirements for $\overline{\text{INT3-INT0}}$ response (see Figure 28)

		MIN	NOM	MAX	UNIT
$t_{su}(\overline{\text{INT-H1L}})$	Setup time, $\overline{\text{INT3-INT0}}$ before H1 low	4*			ns
$t_h(\overline{\text{H1L-INT}})$	Hold time, $\overline{\text{INT3-INT0}}$ after H1 low			0	ns
$t_w(\overline{\text{INT}})$	Pulse duration, interrupt to ensure only one interrupt	$P + 5^{*\dagger}$	1.5P	$2P - 5^{*\dagger}$	ns

* Not production tested

† $P = t_{c(H)}$

The interrupt ($\overline{\text{INTx}}$) pins are synchronized inputs that can be asserted at any time during a clock cycle. The TMS320C3x interrupts are selectable as level- or edge-sensitive. Interrupts are detected on the falling edge of H1. Therefore, interrupts must be set up and held to the falling edge of the internal H1 for proper detection. The CPU and DMA respond to detected interrupts on instruction-fetch boundaries only.

For the processor to recognize only one interrupt when level mode is selected, an interrupt pulse must be set up and held such that a logic-low condition occurs for:

- A minimum of one H1 falling edge
- No more than two H1 falling edges
- Interrupt sources whose edges cannot be specified to meet the H1 falling edge setup and hold times must be further restricted in pulse width as defined by $t_w(\overline{\text{INT}})$ (parameter 51) in the table above.

When $\text{EDGEMODE}=1$, the falling edge of the $\overline{\text{INT0-INT3}}$ pins are detected using synchronous logic (see Figure 7). The pulse low and high time should be two CPU clocks or greater.

The TMS320C3x can set the interrupt flag from the same source as quickly as two H1 clock cycles after it has been cleared.

If the specified timings are met, the exact sequence shown in Figure 28 occurs; otherwise, an additional delay of one clock cycle is possible.



interrupt response timing (continued)

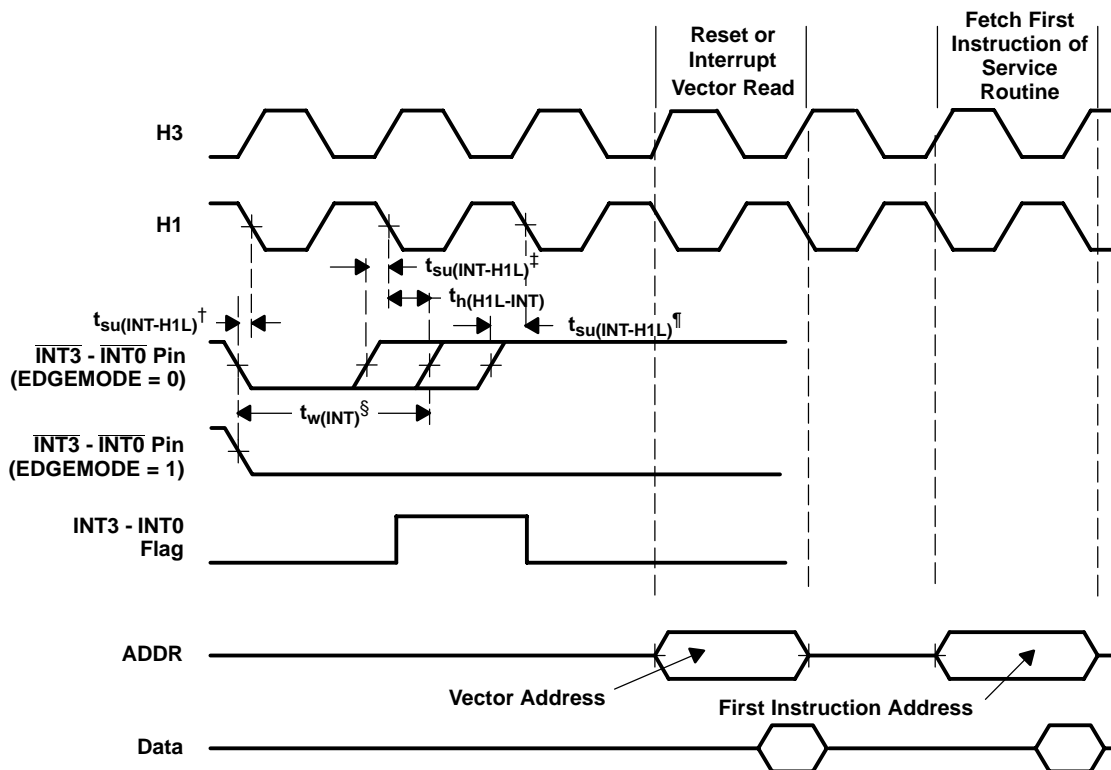

† Falling edge of H1 just detects \overline{INTx} falling edge.

‡ Falling edge of H1 detects second \overline{INTx} low, however flag clear takes precedence.

§ Nominal width.

¶ Falling edge of H1 misses previous \overline{INTx} low as \overline{INTx} rises.

Figure 28. $\overline{INT3-INT0}$ Response Timing

SM320VC33, SMJ320VC33 DIGITAL SIGNAL PROCESSOR

SGUS034E - FEBRUARY 2001 - REVISED OCTOBER 2002

interrupt-acknowledge timing

The $\overline{\text{IACK}}$ output goes active on the first half-cycle (H1 rising) of the decode phase of the IACK instruction and goes inactive at the first half-cycle (H1 rising) of the read phase of the IACK instruction.

The following table defines the timing parameters for the $\overline{\text{IACK}}$ signal. The numbers shown in Figure 29 correspond with those in the NO. column of the table below.

NOTE: The IACK instruction can be executed at anytime to signal an event. It is most often used within an interrupt routine to signal which interrupt has occurred.

switching characteristics over recommended operating conditions for $\overline{\text{IACK}}$ (see Figure 29)

PARAMETER		MIN	MAX	UNIT
$t_{d(H1H-IACKL)}$	Delay time, H1 high to $\overline{\text{IACK}}$ low	-1*	3	ns
$t_{d(H1H-IACKH)}$	Delay time, H1 high to $\overline{\text{IACK}}$ high	-1*	3	ns

* Not production tested

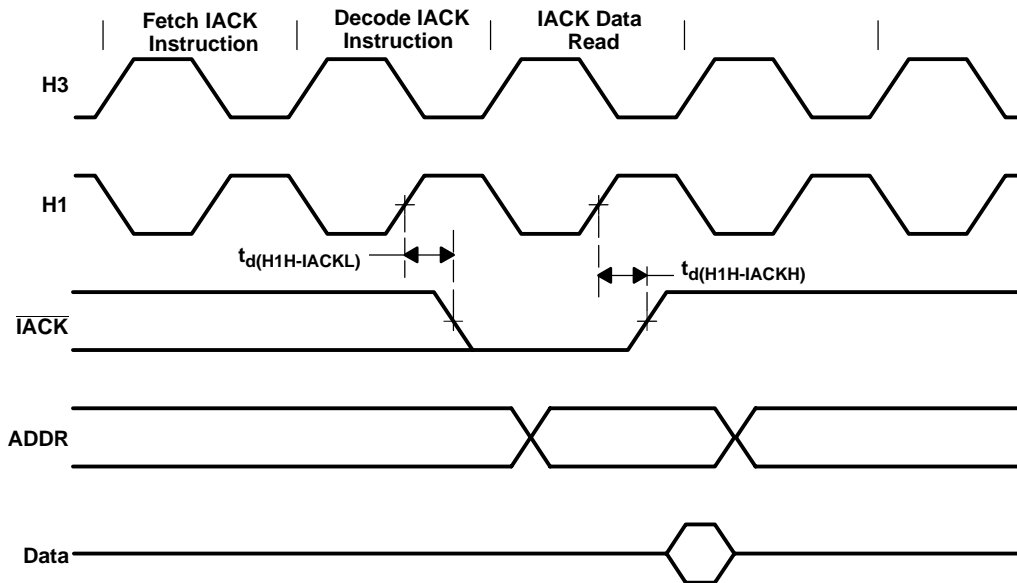

Figure 29. Interrupt Acknowledge ($\overline{\text{IACK}}$) Timing

serial-port timing parameters

The following tables define the timing parameters for the serial port.

timing requirements (see Figure 30 and Figure 31)

		MIN	MAX	UNIT
$t_{c(SCK)}$	Cycle time, CLKX/R	CLKX/R ext	$t_{c(H)} \times 2.6^*$	ns
		CLKX/R int	$t_{c(H)} \times 4^{*\dagger}$ $t_{c(H)} \times 2^{16^*}$	
$t_{w(SCK)}$	Pulse duration, CLKX/R high/low	CLKX/R ext	$t_{c(H)} + 5$	ns
		CLKX/R int	$[t_{c(SCK)}/2] - 4^*$ $[t_{c(SCK)}/2] + 4^*$	
$t_r(SCK)$	Rise time, CLKX/R		3*	ns
$t_f(SCK)$	Fall time, CLKX/R		3*	ns
$t_{su(DR-CLKRL)}$	Setup time, DR before CLKR low	CLKR ext	4*	ns
		CLKR int	5*	
$t_h(CLKRL-DR)$	Hold time, DR after CLKR low	CLKR ext	3*	ns
		CLKR int	0*	
$t_{su(FSR-CLKRL)}$	Setup time, FSR before CLKR low	CLKR ext	4*	ns
		CLKR int	5*	
$t_h(SCKL-FS)$	Hold time, FSX/R input after CLKX/R low	CLKX/R ext	3*	ns
		CLKX/R int	0*	
$t_{su(FSX-CLKX)}$	Setup time, external FSX before CLKX	CLKX ext	$-[t_{c(H)} - 6]$ $[t_{c(SCK)}/2] - 6^*$	ns
		CLKX int	$-[t_{c(H)} - 10]^*$ $t_{c(SCK)}/2^*$	

* Not production tested

† A cycle time of $t_{c(H)} \times 2$ is possible when the device is operated at lower CPU frequencies. See the *TMS320VC33 Silicon Update* (literature number SPRZ176) for further details.

switching characteristics over recommended operating conditions (see Figure 30 and Figure 31)

PARAMETER		MIN	MAX	UNIT
$t_{d(H1H-SCK)}$	Delay time, H1 high to internal CLKX/R		4*	ns
$t_{d(CLKX-DX)}$	Delay time, CLKX to DX valid	CLKX ext	6	ns
		CLKX int	5*	
$t_{d(CLKX-FSX)}$	Delay time, CLKX to internal FSX high/low	CLKX ext	5	ns
		CLKX int	4*	
$t_{d(CLKX-DX)V}$	Delay time, CLKX to first DX bit, FSX precedes CLKX high	CLKX ext	4	ns
		CLKX int	5*	
$t_{d(FSX-DX)V}$	Delay time, FSX to first DX bit, CLKX precedes FSX		6	ns
$t_{dis(CLKX-DXZ)}$	Disable time, DX high impedance following last data bit from CLKX high		6	ns

* Not production tested

SM320VC33, SMJ320VC33 DIGITAL SIGNAL PROCESSOR

SGUS034E - FEBRUARY 2001 - REVISED OCTOBER 2002

data-rate timing modes

Unless otherwise indicated, the data-rate timings shown in Figure 30 and Figure 31 are valid for all serial-port modes, including handshake. For a functional description of serial-port operation, see the *TMS320C3x User's Guide* (literature number SPRU031).

The serial-port timing parameters are defined in the preceding "serial-port timing parameters" tables. The numbers shown in Figure 30 and Figure 31 correspond with those in the NO. column of each table.

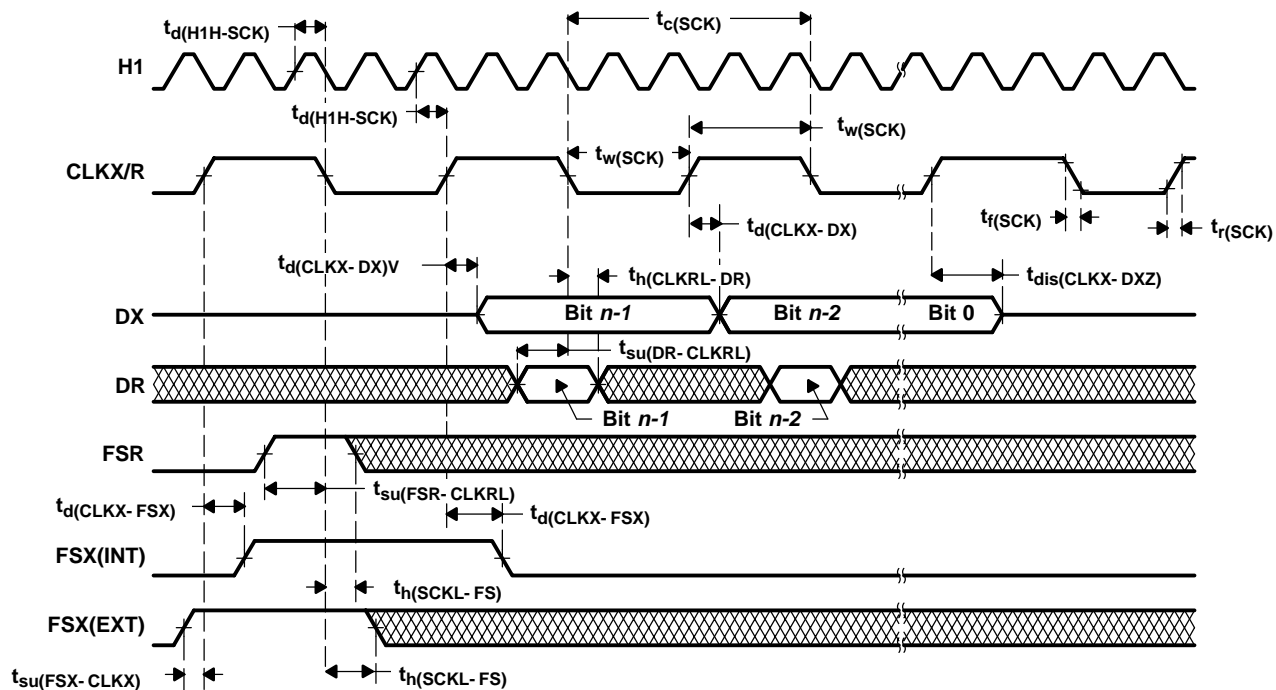

- NOTES: A. Timing diagrams show operations with $CLKXP = CLKRP = FSXP = FSRP = 0$.
B. Timing diagrams depend on the length of the serial-port word, where $n = 8, 16, 24,$ or 32 bits, respectively.

Figure 30. Fixed Data-Rate Mode Timing

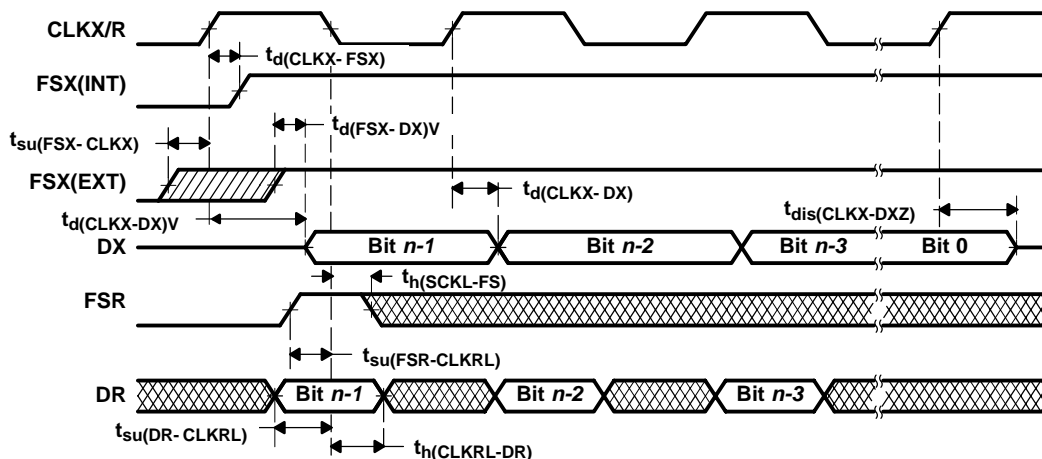

- NOTES: A. Timing diagrams show operation with $CLKXP = CLKRP = FSXP = FSRP = 0$.
B. Timing diagrams depend on the length of the serial-port word, where $n = 8, 16, 24,$ or 32 bits, respectively.
C. The timings that are not specified expressly for the variable data-rate mode are the same as those that are specified for the fixed data-rate mode.

Figure 31. Variable Data-Rate Mode Timing



HOLD timing

$\overline{\text{HOLD}}$ is a synchronous input that can be asserted at any time during a clock cycle. If the specified timings are met, the exact sequence shown in Figure 32 and Figure 33 occurs; otherwise, an additional delay of one clock cycle is possible.

The table, "timing parameters for $\overline{\text{HOLD}}/\overline{\text{HOLDA}}$ ", defines the timing parameters for the $\overline{\text{HOLD}}$ and $\overline{\text{HOLDA}}$ signals. The numbers shown in Figure 32 and Figure 33 correspond with those in the NO. column of the table.

The NOHOLD bit of the primary-bus control register overrides the $\overline{\text{HOLD}}$ signal. When this bit is set, the device comes out of hold and prevents future hold cycles.

Asserting $\overline{\text{HOLD}}$ prevents the processor from accessing the primary bus. Program execution continues until a read from or a write to the primary bus is requested. In certain circumstances, the first write is pending, thus allowing the processor to continue (internally) until a second external write is encountered.

Figure 32, Figure 33, and the accompanying timings are for a zero wait-state bus configuration. Since $\overline{\text{HOLD}}$ is internally captured by the CPU on the H1 falling edge one cycle before the present cycle is terminated, the minimum $\overline{\text{HOLD}}$ width for any bus configuration is, therefore, WTCNT+3. Also, $\overline{\text{HOLD}}$ should not be deasserted before $\overline{\text{HOLDA}}$ has been active for at least one cycle.

timing requirements for $\overline{\text{HOLD}}/\overline{\text{HOLDA}}$ (see Figure 32 and Figure 33)

		MIN	MAX	UNIT
$t_{\text{su}}(\overline{\text{HOLD}}\text{-H1L})$	Setup time, $\overline{\text{HOLD}}$ before H1 low	3		ns
$t_{\text{w}}(\overline{\text{HOLD}})$	Pulse duration, $\overline{\text{HOLD}}$ low	$3t_{\text{c(H)}}^*$		ns

*Not production tested.

switching characteristics over recommended operating conditions for $\overline{\text{HOLD}}/\overline{\text{HOLDA}}$ (see Figure 32 and Figure 33)

PARAMETER		MIN	MAX	UNIT
$t_{\text{v}}(\text{H1L-HOLDA})$	Valid time, $\overline{\text{HOLDA}}$ after H1 low	-1*	3*	ns
$t_{\text{w}}(\overline{\text{HOLDA}})$	Pulse duration, $\overline{\text{HOLDA}}$ low	$2t_{\text{c(H)}} - 4^*$		ns
$t_{\text{d}}(\text{H1L-SH})\text{H}$	Delay time, H1 low to $\overline{\text{STRB}}$ high for a $\overline{\text{HOLD}}$	-1	3	ns
$t_{\text{dis}}(\text{H1L-S})$	Disable time, $\overline{\text{STRB}}$ to the high-impedance state from H1 low		4	ns
$t_{\text{en}}(\text{H1L-S})$	Enable time, $\overline{\text{STRB}}$ enabled (active) from H1 low		4	ns
$t_{\text{dis}}(\text{H1L-RW})$	Disable time, $\overline{\text{R/W}}$ to the high-impedance state from H1 low		5*	ns
$t_{\text{en}}(\text{H1L-RW})$	Enable time, $\overline{\text{R/W}}$ enabled (active) from H1 low		4	ns
$t_{\text{dis}}(\text{H1L-A})$	Disable time, Address to the high-impedance state from H1 low		4*	ns
$t_{\text{en}}(\text{H1L-A})$	Enable time, Address enabled (valid) from H1 low		5	ns
$t_{\text{dis}}(\text{H1H-D})$	Disable time, Data to the high-impedance state from H1 high		4*	ns

* Not production tested

SM320VC33, SMJ320VC33 DIGITAL SIGNAL PROCESSOR

SGUS034E - FEBRUARY 2001 - REVISED OCTOBER 2002

HOLD timing (continued)

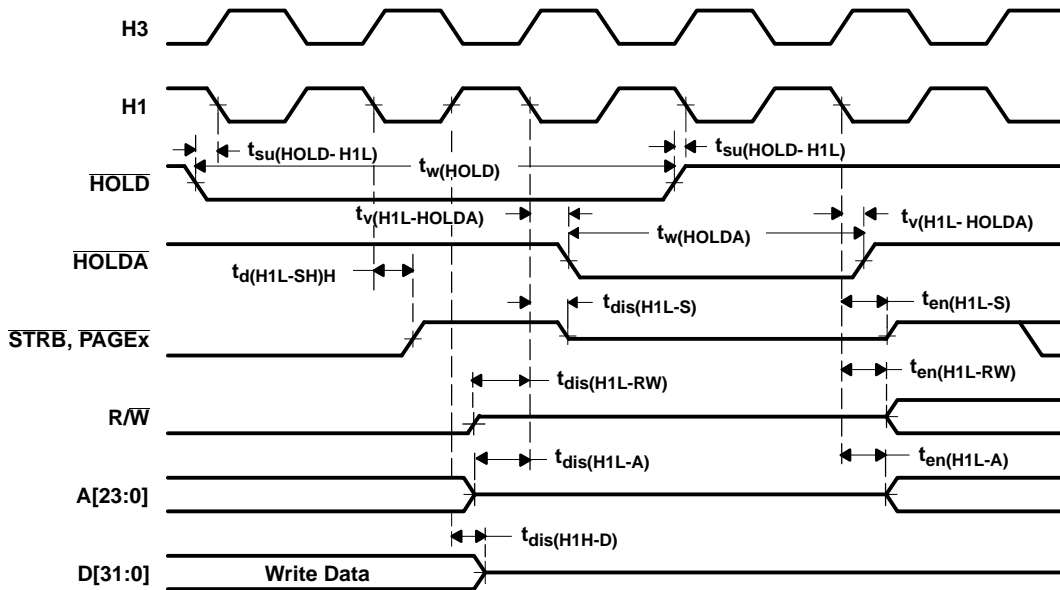

NOTE A: $\overline{\text{HOLDA}}$ goes low in response to $\overline{\text{HOLD}}$ going low and continues to remain low until one H1 cycle after $\overline{\text{HOLD}}$ goes back high.

Figure 32. Timing for $\overline{\text{HOLD}}/\overline{\text{HOLDA}}$ (After Write)

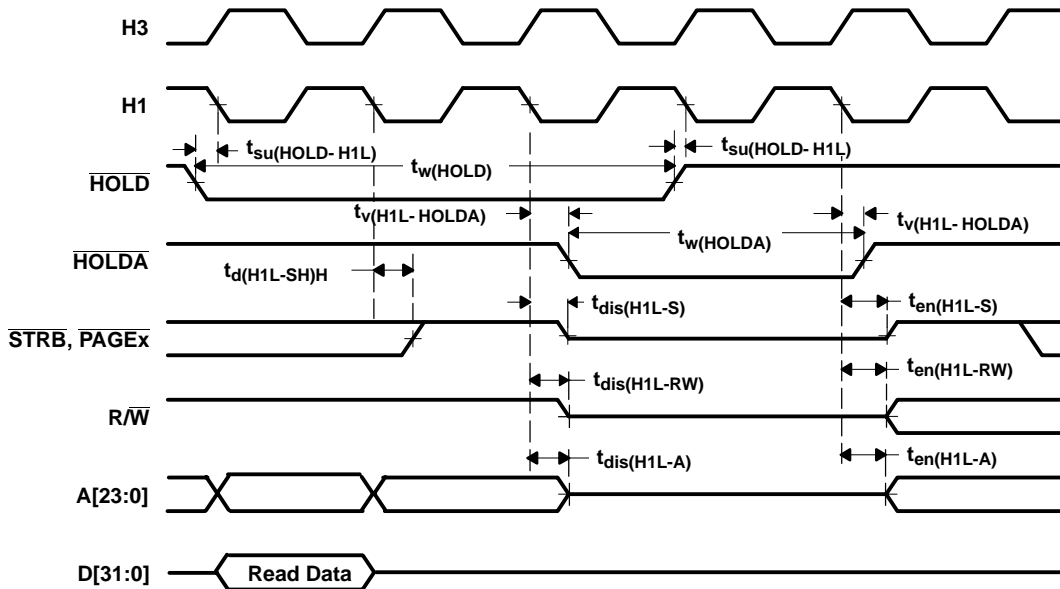

NOTE A: $\overline{\text{HOLDA}}$ goes low in response to $\overline{\text{HOLD}}$ going low and continues to remain low until one H1 cycle after $\overline{\text{HOLD}}$ goes back high.

Figure 33. Timing for $\overline{\text{HOLD}}/\overline{\text{HOLDA}}$ (After Read)

general-purpose I/O timing

Peripheral pins include CLKX0, CLKR0, DX0, DR0, FSX0, FSR0, and TCLK0/1. The contents of the internal control registers associated with each peripheral define the modes for these pins.

peripheral pin I/O timing

The following table shows the timing parameters for changing the peripheral pin from a general-purpose output pin to a general-purpose input pin and vice versa.

timing requirements for peripheral pin general-purpose I/O (see Note 1, Figure 34, and Figure 35)

		MIN	MAX	UNIT
$t_{su}(GPIO-H1L)$	Setup time, general-purpose input before H1 low	3*		ns
$t_{h}(H1L-GPIO)$	Hold time, general-purpose input after H1 low	0*		ns

* Not production tested

NOTE 1: Peripheral pins include CLKX0, CLKR0, DX0, DR0, FSX0, FSR0, and TCLK0/1. The modes of these pins are defined by the contents of internal-control registers associated with each peripheral.

switching characteristics over recommended operating conditions for peripheral pin general-purpose I/O (see Note 1, Figure 34, and Figure 35)

PARAMETER	MIN	MAX	UNIT
$t_{d}(H1H-GPIO)$		4	ns
$t_{dis}(H1H)$		5	ns

NOTE 1: Peripheral pins include CLKX0, CLKR0, DX0, DR0, FSX0, FSR0, and TCLK0/1. The modes of these pins are defined by the contents of internal-control registers associated with each peripheral.

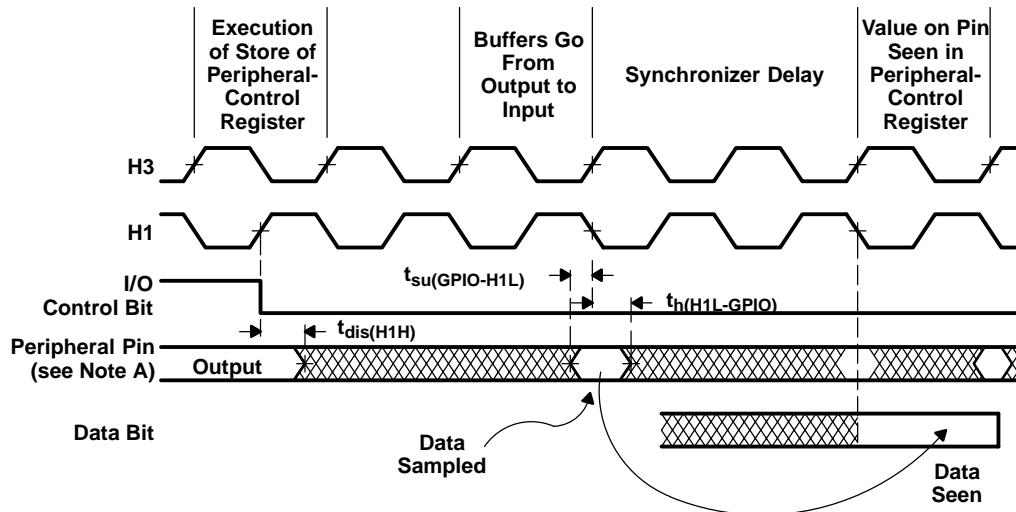

NOTE A: Peripheral pins include CLKX0, CLKR0, DX0, DR0, FSX0, FSR0, and TCLK0/1.

Figure 34. Change of Peripheral Pin From General-Purpose Output to Input Mode Timing

SM320VC33, SMJ320VC33 DIGITAL SIGNAL PROCESSOR

SGUS034E - FEBRUARY 2001 - REVISED OCTOBER 2002

peripheral pin I/O timing (continued)

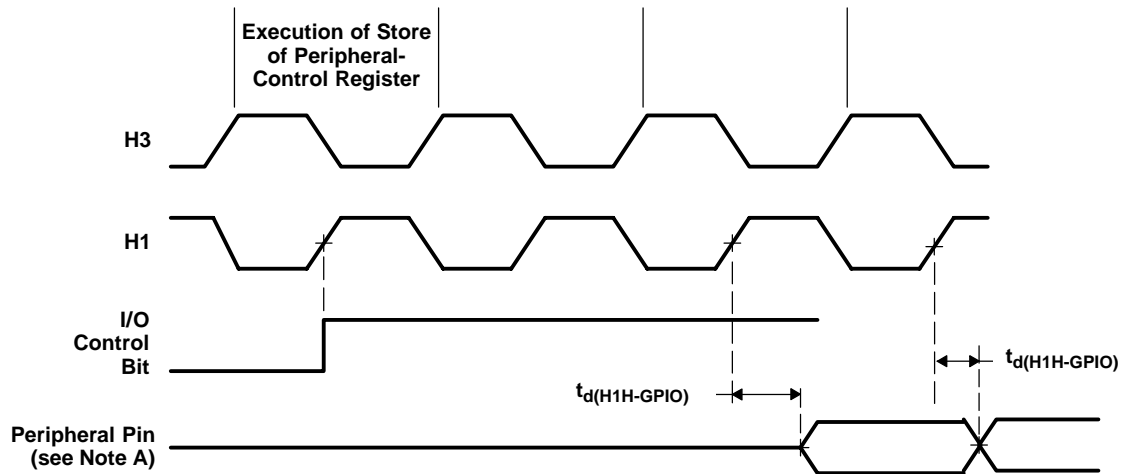

NOTE A: Peripheral pins include CLKX0, CLKR0, DX0, DR0, FSX0, FSR0, and TCLK0/1.

Figure 35. Change of Peripheral Pin From General-Purpose Input to Output Mode Timing

timer pin timing

Valid logic-level periods and polarity are specified by the contents of the internal control registers. The following tables define the timing parameters for the timer pin.

timing requirements for timer pin (see Figure 36 and Figure 37)

	MIN	MAX	UNIT
$t_{su}(TCLK-H1L)^\dagger$ Setup time, TCLK external before H1 low	3*		ns
$t_h(H1L-TCLK)^\dagger$ Hold time, TCLK external after H1 low	0		ns

* Not production tested

† These requirements are applicable for a synchronous input clock.

switching characteristics over recommended operating conditions for timer pin (see Figure 36 and Figure 37)

PARAMETER	MIN	MAX	UNIT
$t_d(H1H-TCLK)$ Delay time, H1 high to TCLK internal valid		3	ns
$t_c(TCLK)^\ddagger$ Cycle time, TCLK	TCLK ext	$t_c(H) \times 2.6^*$	ns
	TCLK int	$t_c(H) \times 2^*$ $t_c(H) \times 2^{32^*}$	
$t_w(TCLK)^\ddagger$ Pulse duration, TCLK	TCLK ext	$t_c(H) + 5^*$	ns
	TCLK int	$[t_c(TCLK)/2] - 4^*$ $[t_c(TCLK)/2] + 4^*$	

* Not production tested

‡ These parameters are applicable for an asynchronous input clock.

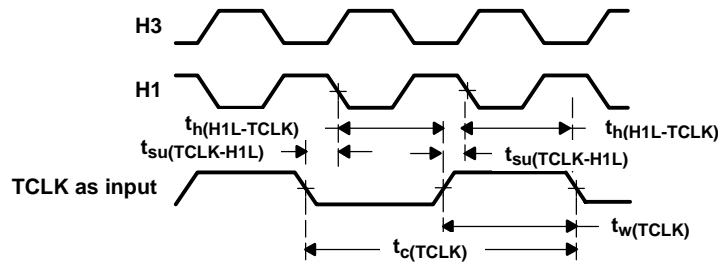

Figure 36. Timer Pin Timing, Input

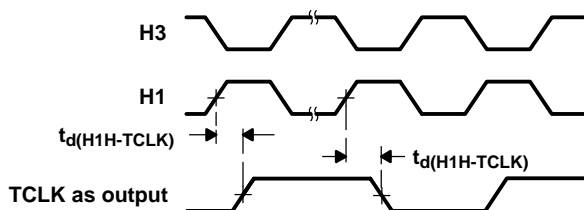

Figure 37. Timer Pin Timing, Output

SM320VC33, SMJ320VC33 DIGITAL SIGNAL PROCESSOR

SGUS034E - FEBRUARY 2001 - REVISED OCTOBER 2002

SHZ pin timing

The following table defines the timing parameter for the SHZ pin.

switching characteristics over recommended operating conditions for SHZ (see Figure 38)

PARAMETER		MIN	MAX	UNIT
$t_{dis}(SHZ)$	Disable time, SHZ low to all outputs, I/O pins disabled (high impedance)	0*	8*	ns

* Not production tested

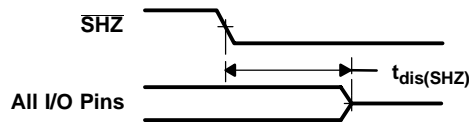

NOTE A: Enabling SHZ destroys SM/SMJ320VC33 register and memory contents. Assert SHZ = 1 and reset the SM/SMJ320VC33 to restore it to a known condition.

Figure 38. Timing for SHZ

test access port timing

The following table defines the timing parameter for the test access port.

timing for test access port (see Figure 39)

		MIN	MAX	UNIT
$t_{su}(TMS-TCKH)$	Setup time, TMS/TDI to TCK high	5*		ns
$t_h(TCKH-TMS)$	Hold time, TMS/TDI from TCK high	5*		ns
$t_d(TCKL-TDOV)$	Delay time, TCK low to TDO valid	0*	10*	ns
$t_r(TCK)$	Rise time, TCK		3*	ns
$t_f(TCK)$	Fall time, TCK		3*	ns

* Not production tested

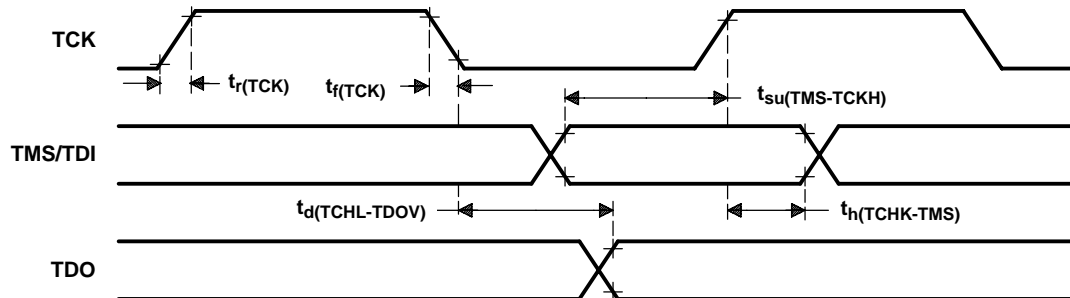
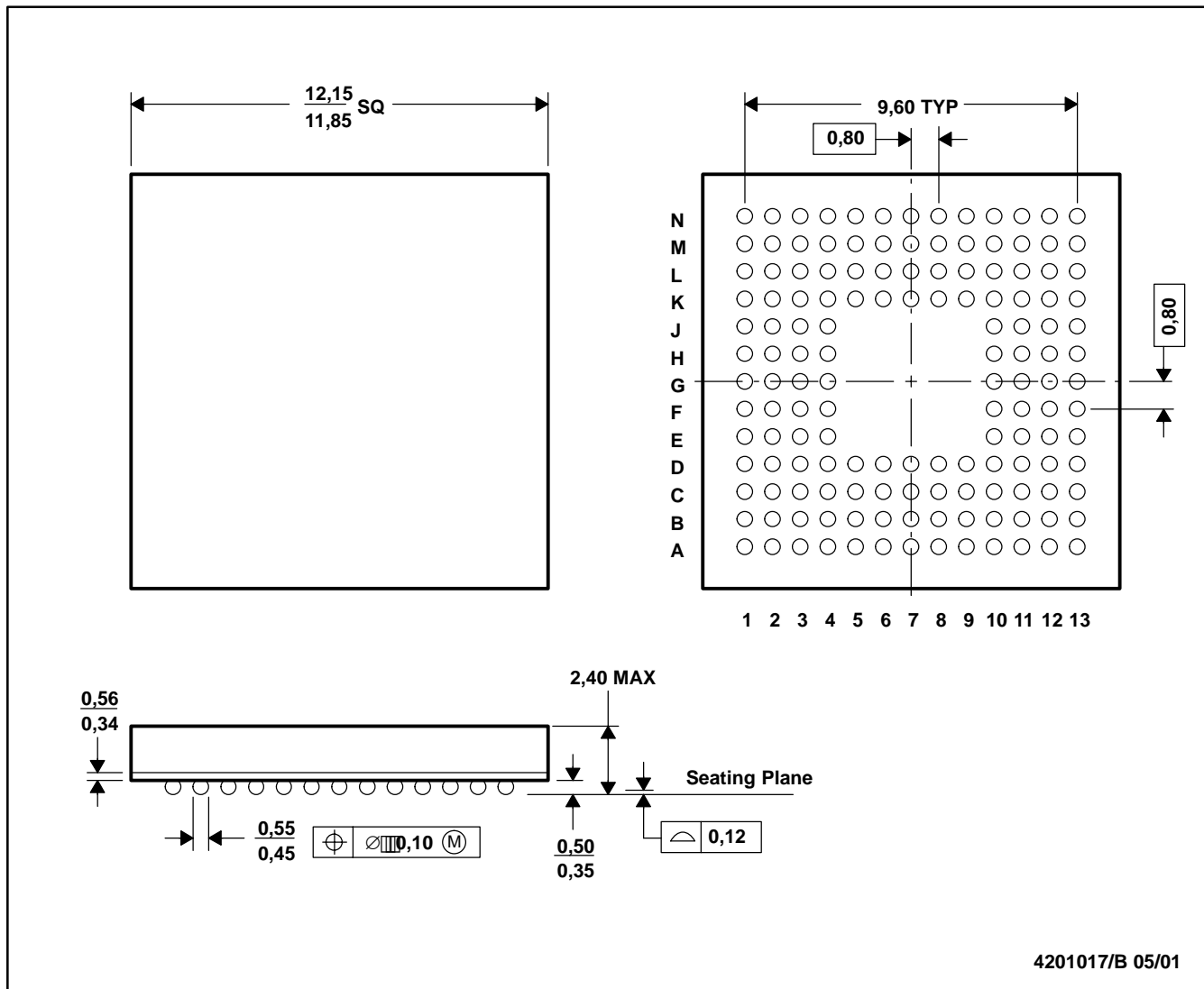

Figure 39. IEEE-1149.1 Test Access Port Timings

MECHANICAL DATA

GNM (S-CBGA-N144)

CERAMIC BALL GRID ARRAY



- NOTES: A. All linear dimensions are in millimeters.
B. This drawing is subject to change without notice.

SM320VC33, SMJ320VC33 DIGITAL SIGNAL PROCESSOR

SGUS034E - FEBRUARY 2001 - REVISED OCTOBER 2002

MECHANICAL DATA

HFG (S-CQFP-F164)

CERAMIC QUAD FLATPACK WITH NCTB

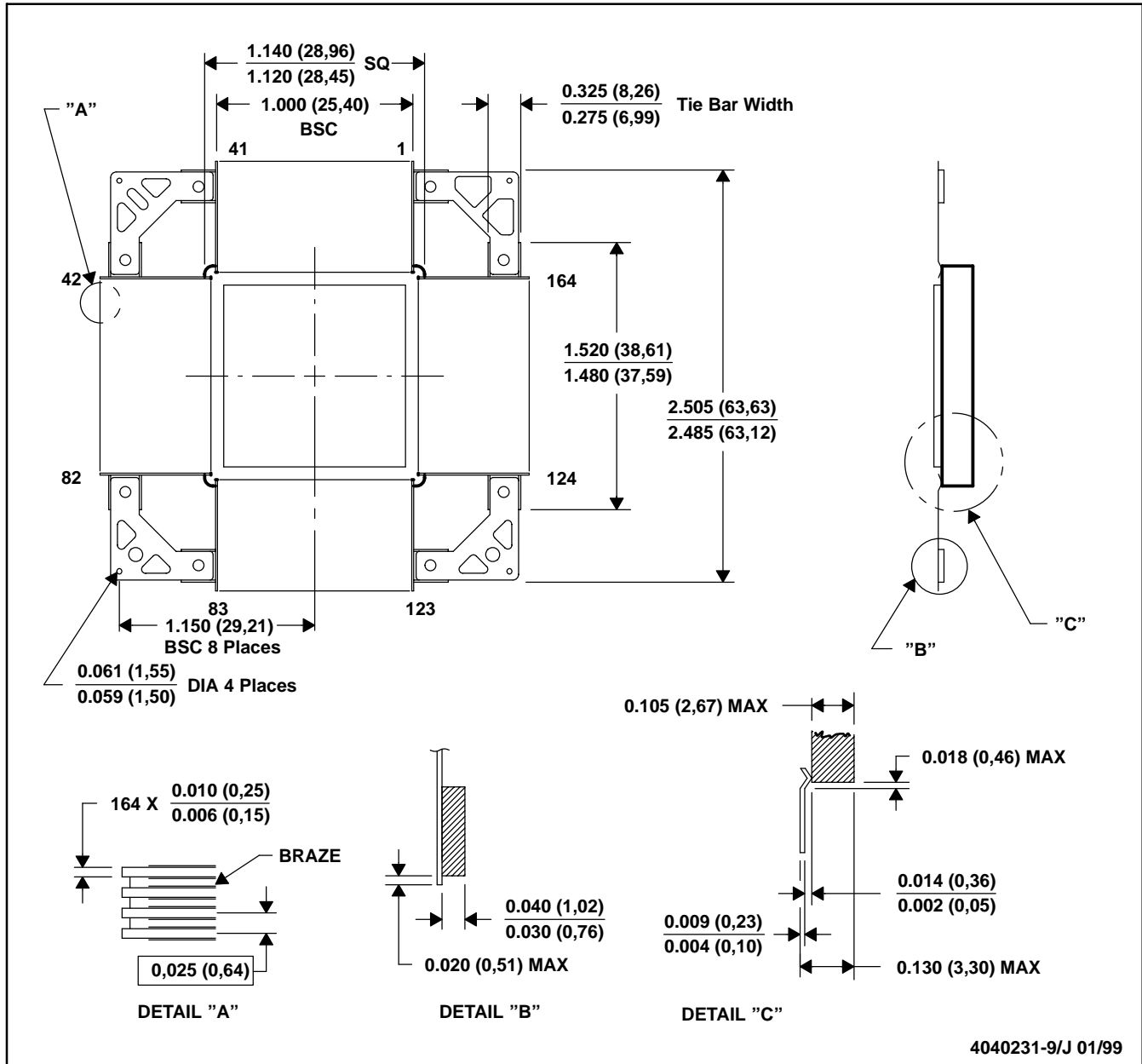

4040231-9/J 01/99

- NOTES: C. All linear dimensions are in inches (millimeters).
D. This drawing is subject to change without notice.
E. Ceramic quad flatpack with flat leads brazed to non-conductive tie bar carrier
F. This package is hermetically sealed with a metal lid.
G. The leads are gold-plated and can be solder-dipped.
H. Leads not shown for clarity purposes
I. Falls within JEDEC MO-113AA (REV D)



POST OFFICE BOX 1443 • HOUSTON, TEXAS 77251-1443

PACKAGING INFORMATION

Orderable Device	Status ⁽¹⁾	Package Type	Package Drawing	Pins	Package Qty	Eco Plan ⁽²⁾	Lead/Ball Finish	MSL Peak Temp ⁽³⁾
5962-0053901QYA	ACTIVE	CFP	HFG	164	1	None	Call TI	Level-NC-NC-NC
5962-0053901QYC	ACTIVE	CFP	HFG	164	1	None	Call TI	Level-NC-NC-NC
5962-0053902QYA	ACTIVE	CFP	HFG	164	1	None	Call TI	Level-NC-NC-NC
5962-0053902QYC	ACTIVE	CFP	HFG	164	4	None	Call TI	Level-NC-NC-NC
SM320VC33GNMM150	ACTIVE	CBGA	GNM	144	1	None	Call TI	Level-1-235C-UNLIM
SMJ320VC33HFGM150	ACTIVE	CFP	HFG	164	1	None	Call TI	Level-NC-NC-NC

⁽¹⁾ The marketing status values are defined as follows:

ACTIVE: Product device recommended for new designs.

LIFEBUY: TI has announced that the device will be discontinued, and a lifetime-buy period is in effect.

NRND: Not recommended for new designs. Device is in production to support existing customers, but TI does not recommend using this part in a new design.

PREVIEW: Device has been announced but is not in production. Samples may or may not be available.

OBSOLETE: TI has discontinued the production of the device.

⁽²⁾ Eco Plan - May not be currently available - please check <http://www.ti.com/productcontent> for the latest availability information and additional product content details.

None: Not yet available Lead (Pb-Free).

Pb-Free (RoHS): TI's terms "Lead-Free" or "Pb-Free" mean semiconductor products that are compatible with the current RoHS requirements for all 6 substances, including the requirement that lead not exceed 0.1% by weight in homogeneous materials. Where designed to be soldered at high temperatures, TI Pb-Free products are suitable for use in specified lead-free processes.

Green (RoHS & no Sb/Br): TI defines "Green" to mean "Pb-Free" and in addition, uses package materials that do not contain halogens, including bromine (Br) or antimony (Sb) above 0.1% of total product weight.

⁽³⁾ MSL, Peak Temp. -- The Moisture Sensitivity Level rating according to the JEDEC industry standard classifications, and peak solder temperature.

Important Information and Disclaimer: The information provided on this page represents TI's knowledge and belief as of the date that it is provided. TI bases its knowledge and belief on information provided by third parties, and makes no representation or warranty as to the accuracy of such information. Efforts are underway to better integrate information from third parties. TI has taken and continues to take reasonable steps to provide representative and accurate information but may not have conducted destructive testing or chemical analysis on incoming materials and chemicals. TI and TI suppliers consider certain information to be proprietary, and thus CAS numbers and other limited information may not be available for release.

In no event shall TI's liability arising out of such information exceed the total purchase price of the TI part(s) at issue in this document sold by TI to Customer on an annual basis.

IMPORTANT NOTICE

Texas Instruments Incorporated and its subsidiaries (TI) reserve the right to make corrections, modifications, enhancements, improvements, and other changes to its products and services at any time and to discontinue any product or service without notice. Customers should obtain the latest relevant information before placing orders and should verify that such information is current and complete. All products are sold subject to TI's terms and conditions of sale supplied at the time of order acknowledgment.

TI warrants performance of its hardware products to the specifications applicable at the time of sale in accordance with TI's standard warranty. Testing and other quality control techniques are used to the extent TI deems necessary to support this warranty. Except where mandated by government requirements, testing of all parameters of each product is not necessarily performed.

TI assumes no liability for applications assistance or customer product design. Customers are responsible for their products and applications using TI components. To minimize the risks associated with customer products and applications, customers should provide adequate design and operating safeguards.

TI does not warrant or represent that any license, either express or implied, is granted under any TI patent right, copyright, mask work right, or other TI intellectual property right relating to any combination, machine, or process in which TI products or services are used. Information published by TI regarding third-party products or services does not constitute a license from TI to use such products or services or a warranty or endorsement thereof. Use of such information may require a license from a third party under the patents or other intellectual property of the third party, or a license from TI under the patents or other intellectual property of TI.

Reproduction of information in TI data books or data sheets is permissible only if reproduction is without alteration and is accompanied by all associated warranties, conditions, limitations, and notices. Reproduction of this information with alteration is an unfair and deceptive business practice. TI is not responsible or liable for such altered documentation.

Resale of TI products or services with statements different from or beyond the parameters stated by TI for that product or service voids all express and any implied warranties for the associated TI product or service and is an unfair and deceptive business practice. TI is not responsible or liable for any such statements.

Following are URLs where you can obtain information on other Texas Instruments products and application solutions:

Products		Applications	
Amplifiers	amplifier.ti.com	Audio	www.ti.com/audio
Data Converters	dataconverter.ti.com	Automotive	www.ti.com/automotive
DSP	dsp.ti.com	Broadband	www.ti.com/broadband
Interface	interface.ti.com	Digital Control	www.ti.com/digitalcontrol
Logic	logic.ti.com	Military	www.ti.com/military
Power Mgmt	power.ti.com	Optical Networking	www.ti.com/opticalnetwork
Microcontrollers	microcontroller.ti.com	Security	www.ti.com/security
		Telephony	www.ti.com/telephony
		Video & Imaging	www.ti.com/video
		Wireless	www.ti.com/wireless

Mailing Address: Texas Instruments
Post Office Box 655303 Dallas, Texas 75265