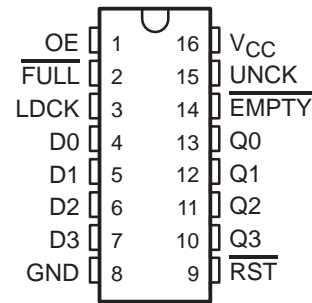

- Independent Asynchronous Inputs and Outputs
- 16 Words by 4 Bits
- Data Rates up to 40 MHz
- Fall-Through Time 14 ns Typical
- 3-State Outputs
- Package Options Include Plastic Small-Outline Package (DW), Plastic Chip Carriers (FN), and Standard Plastic 300-mil DIPs (N)

DW OR N PACKAGE
(TOP VIEW)

description

This 64-bit memory features high speed and fast fall-through times. It is organized as 16 words by 4 bits.

A first-in, first-out (FIFO) memory is a storage device that allows data to be written into and read from its array at independent data rates. This FIFO is designed to process data at rates up to 40 MHz in a bit-parallel format, word by word.

Data is written into memory on a low-to-high transition at the load-clock (LDCK) input and is read out on a low-to-high transition at the unload-clock (UNCK) input. The memory is full when the number of words clocked in exceeds by 16 the number of words clocked out. When the memory is full, LDCK signals have no effect on the data residing in memory. When the memory is empty, UNCK signals have no effect.

Status of the FIFO memory is monitored by the $\overline{\text{FULL}}$ and $\overline{\text{EMPTY}}$ output flags. The $\overline{\text{FULL}}$ output is low when the memory is full and high when it is not full. The $\overline{\text{EMPTY}}$ output is low when the memory is empty and high when it is not empty.

A low level on the reset ($\overline{\text{RST}}$) input resets the internal stack-control pointers and also sets $\overline{\text{EMPTY}}$ low and sets $\overline{\text{FULL}}$ high. The Q outputs are not reset to any specific logic level. The first low-to-high transition on LDCK, after either a $\overline{\text{RST}}$ pulse or from an empty condition, causes $\overline{\text{EMPTY}}$ to go high and the data to appear on the Q outputs. It is important to note that the first word does not have to be unloaded. Data outputs are noninverting with respect to the data inputs and are at high impedance when the output-enable (OE) input is low. OE does not affect the $\overline{\text{FULL}}$ or $\overline{\text{EMPTY}}$ output flags. Cascading is easily accomplished in the word-width direction but is not possible in the word-depth direction.

The SN74ALS232B is characterized for operation from 0°C to 70°C.

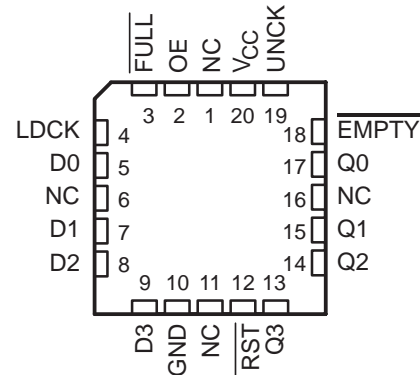
FN PACKAGE
(TOP VIEW)

NC – No internal connection



Please be aware that an important notice concerning availability, standard warranty, and use in critical applications of Texas Instruments semiconductor products and disclaimers thereto appears at the end of this data sheet.

PRODUCTION DATA information is current as of publication date. Products conform to specifications per the terms of Texas Instruments standard warranty. Production processing does not necessarily include testing of all parameters.

 **TEXAS
INSTRUMENTS**

POST OFFICE BOX 655303 • DALLAS, TEXAS 75265

Copyright © 1998, Texas Instruments Incorporated

SN74ALS232B

16 × 4 ASYNCHRONOUS FIRST-IN, FIRST-OUT MEMORY

SCAS251B – FEBRUARY 1989 – REVISED APRIL 1998

logic symbol†

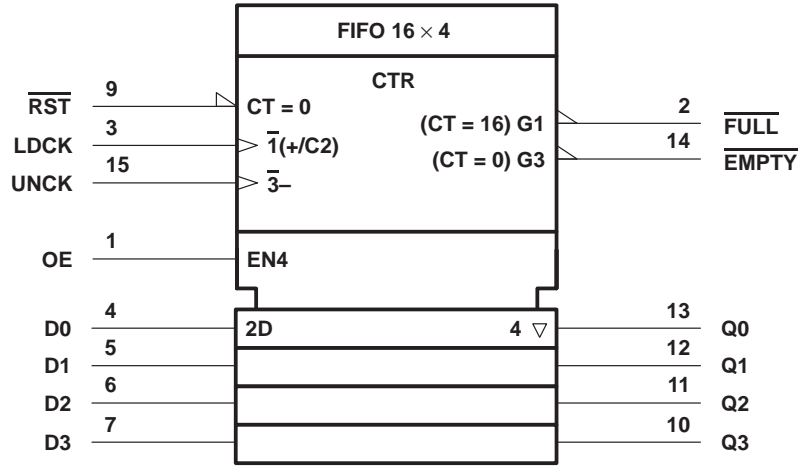

† This symbol is in accordance with ANSI/IEEE Standard 91-1984 and IEC Publication 617-12. The symbol is functionally accurate but does not show the details of implementation; for these, see the logic diagram. The symbol represents the memory as if it were controlled by a single counter whose content is the number of words stored at the time. Output data is invalid when the counter content (CT) is 0. Pin numbers shown are for the DW and N packages.

SN74ALS232B

16 × 4 ASYNCHRONOUS FIRST-IN, FIRST-OUT MEMORY

SCAS251B – FEBRUARY 1989 – REVISED APRIL 1998

logic diagram (positive logic)

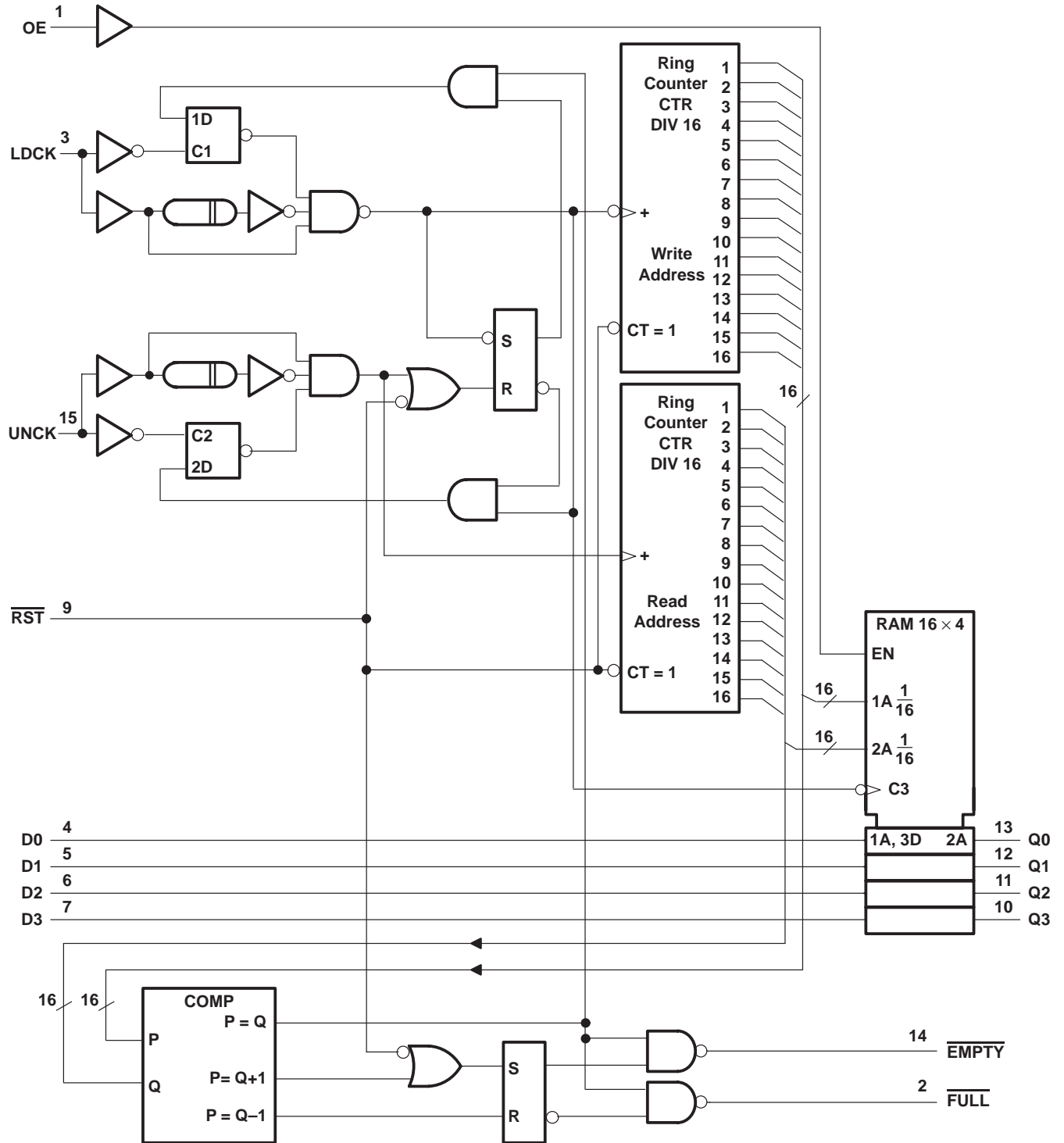

Pin numbers shown are for the DW and N packages.

SN74ALS232B

16 × 4 ASYNCHRONOUS FIRST-IN, FIRST-OUT MEMORY

SCAS251B – FEBRUARY 1989 – REVISED APRIL 1998

timing diagram

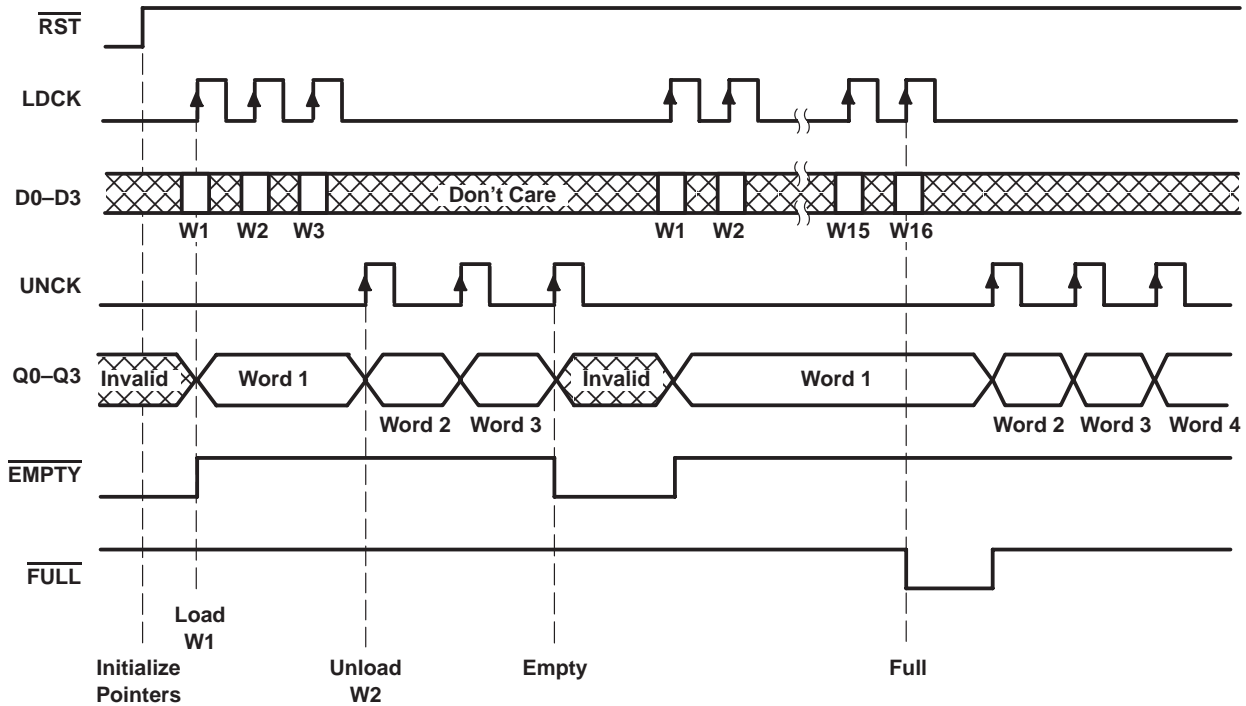

absolute maximum ratings over operating free-air temperature range (unless otherwise noted)†

Supply voltage range, V_{CC}	-0.5 V to 7 V
Input voltage range, V_I	-0.5 V to 7 V
Voltage range applied to a disabled 3-state output	-0.5 V to 5.5 V
Package thermal impedance, θ_{JA} (see Note 2): DW package	105°C/W
FN package	83°C/W
N package	78°C/W
Storage temperature range, T_{stg}	-65°C to 150°C

† Stresses beyond those listed under "absolute maximum ratings" may cause permanent damage to the device. This is a stress rating only, and functional operation of the device at these or any other conditions beyond those indicated in the "recommended operating conditions" section of this specification is not implied. Exposure to absolute-maximum-rated conditions for extended periods may affect device reliability.

NOTES: 1. All voltage values are with respect to GND.

2. The package thermal impedance is calculated in accordance with JESD 51, except for through-hole packages, which use a trace length of zero.



POST OFFICE BOX 655303 • DALLAS, TEXAS 75265

SN74ALS232B

16 × 4 ASYNCHRONOUS FIRST-IN, FIRST-OUT MEMORY

SCAS251B – FEBRUARY 1989 – REVISED APRIL 1998

recommended operating conditions (see Note 3)

		MIN	NOM	MAX	UNIT
V _{CC}	Supply voltage	4.5	5	5.5	V
V _{IH}	High-level input voltage	2			V
V _{IL}	Low-level input voltage			0.8	V
I _{OH}	High-level output current	Q outputs		-2.6	mA
		FULL, EMPTY		-0.4	
I _{OL}	Low-level output current	Q outputs		24	mA
		FULL, EMPTY		8	
T _A	Operating free-air temperature	0		70	°C

NOTE 3: To ensure proper operation of this high-speed FIFO device, it is necessary to provide a clean signal to the LDCK and UNCK clock inputs. Any excessive noise or glitching on the clock inputs that violates limits for maximum V_{IL}, minimum V_{IH}, or minimum pulse duration can cause a false clock or improper operation of the internal read and write pointers.

electrical characteristics over recommended operating free-air temperature range (unless otherwise noted)

PARAMETER		TEST CONDITIONS		MIN	TYP†	MAX	UNIT
V _{IK}		V _{CC} = 4.5 V,	I _I = -18 mA			-1.2	V
V _{OH}	Q outputs	V _{CC} = 4.5 V,	I _{OH} = -2.6 mA	2.4	3.2		V
	FULL, EMPTY	V _{CC} = 4.5 V to 5.5 V,	I _{OH} = -0.4 mA	V _{CC} -2			
V _{OL}	Q outputs	V _{CC} = 4.5 V	I _{OL} = 12 mA		0.25	0.4	V
			I _{OL} = 24 mA		0.35	0.5	
	FULL, EMPTY	V _{CC} = 4.5 V	I _{OL} = 4 mA		0.25	0.4	
			I _{OL} = 8 mA		0.35	0.5	
I _{OZH}		V _{CC} = 5.5 V,	V _O = 2.7 V			20	μA
I _{OZL}		V _{CC} = 5.5 V,	V _O = 0.4 V			-20	μA
I _I		V _{CC} = 5.5 V,	V _I = 7 V			0.1	mA
I _{IH}		V _{CC} = 5.5 V,	V _I = 2.7 V			20	μA
I _{IL}		V _{CC} = 5.5 V,	V _I = 0.4 V			-0.2	mA
I _{O‡}		V _{CC} = 5.5 V,	V _O = 2.25 V	-30		-112	mA
I _{CC}		V _{CC} = 5.5 V			80	125	mA

† All typical values are at V_{CC} = 5 V, T_A = 25°C.

‡ The output conditions have been chosen to produce a current that closely approximates one-half of the true short-circuit output current, I_{OS}.



SN74ALS232B

16 × 4 ASYNCHRONOUS FIRST-IN, FIRST-OUT MEMORY

SCAS251B – FEBRUARY 1989 – REVISED APRIL 1998

timing requirements over recommended operating free-air temperature range (see Figure 1)

		MIN	NOM	MAX	UNIT
f _{clock} †	Clock frequency	LDCK		40	MHz
		UNCK		40	
t _w	Pulse duration	$\overline{\text{RST}}$ low	18		ns
		LDCK low	15		
		LDCK high	10		
		UNCK low	15		
		UNCK high	10		
t _{su}	Setup time	Data before LDCK↑	8		ns
		LDCK inactive before $\overline{\text{RST}}$ ↑	5		
t _h	Hold time	Data after LDCK↑	5		ns
		LDCK inactive after $\overline{\text{RST}}$ ↑	5		

† The maximum possible clock frequency is 40 MHz. The maximum clock frequency when using a 50% duty cycle is 33.3 MHz.

switching characteristics (see Figure 1)

PARAMETER	FROM (INPUT)	TO (OUTPUT)	MIN	TYP‡	MAX	MIN	MAX	UNIT
f _{max}	LDCK, UNCK			50		40		MHz
t _{pd}	LDCK↑	Any Q	14	23	6	30	ns	
	UNCK↑		15	23	6	30		
t _{PLH}	LDCK↑	$\overline{\text{EMPTY}}$	13	20	5	25	ns	
t _{PHL}	UNCK↑	$\overline{\text{EMPTY}}$	15	22	6	27	ns	
	$\overline{\text{RST}}$ ↓		15	21	5	26		
	LDCK↑		$\overline{\text{FULL}}$	15	22	6		27
t _{PLH}	UNCK↑	$\overline{\text{FULL}}$	13	20	5	25	ns	
	$\overline{\text{RST}}$ ↓		16	23	7	28		
t _{en}	OE↑	Q	5	12	1	14	ns	
t _{dis}	OE↓	Q	5	12	1	16	ns	

‡ Typical values at V_{CC} = 5 V, T_A = 25°C.

PARAMETER MEASUREMENT INFORMATION

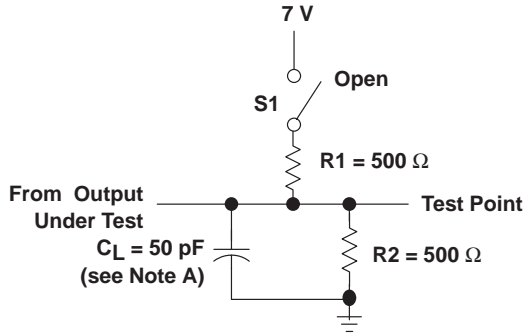

LOAD CIRCUIT FOR 3-STATE OUTPUTS

SWITCH POSITION TABLE

PARAMETER	S1	
t_{en}	t_{PZH}	Open
	t_{PZL}	Closed
t_{dis}	t_{PHZ}	Open
	t_{PLZ}	Closed
t_{pd}	t_{PLH}	Open
	t_{PHL}	Open

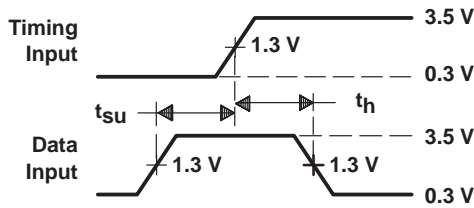

**VOLTAGE WAVEFORMS
SETUP AND HOLD TIMES**

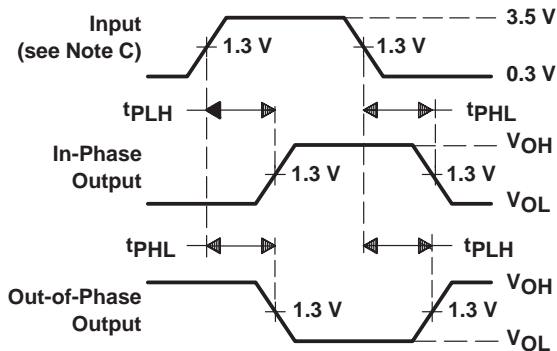

**VOLTAGE WAVEFORMS
PROPAGATION DELAY TIMES**

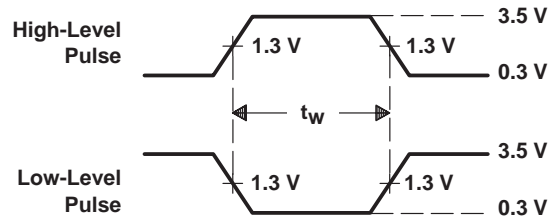

**VOLTAGE WAVEFORMS
PULSE DURATION**

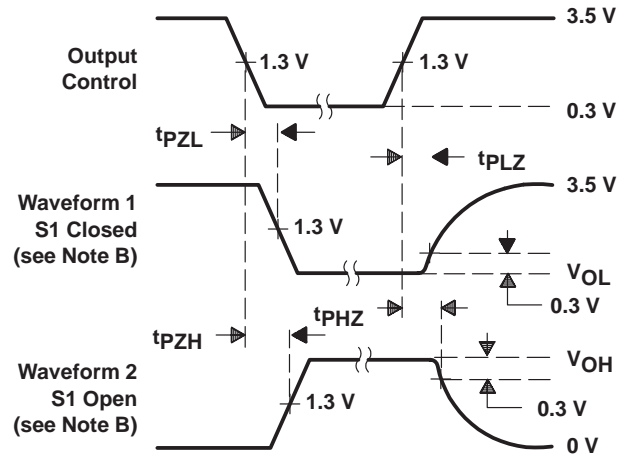

**VOLTAGE WAVEFORMS
ENABLE AND DISABLE TIMES, 3-STATE OUTPUTS**

- NOTES: A. C_L includes probe and jig capacitance.
 B. Waveform 1 is for an output with internal conditions such that the output is low except when disabled by the output control. Waveform 2 is for an output with internal conditions such that the output is high except when disabled by the output control.
 C. All input pulses are supplied by generators having the following characteristics: PRR \leq 1 MHz, $Z_0 = 50 \Omega$, $t_r \leq 2$ ns, $t_f \leq 2$ ns.
 D. The outputs are measured one at a time with one transition per measurement.

Figure 1. Load Circuit and Voltage Waveforms

PACKAGING INFORMATION

Orderable Device	Status ⁽¹⁾	Package Type	Package Drawing	Pins	Package Qty	Eco Plan ⁽²⁾	Lead/ Ball Finish	MSL Peak Temp ⁽³⁾	Samples (Requires Login)
SN74ALS232BDW	ACTIVE	SOIC	DW	16	40	Green (RoHS & no Sb/Br)	CU NIPDAU	Level-1-260C-UNLIM	Purchase Samples
SN74ALS232BN	ACTIVE	PDIP	N	16	25	Pb-Free (RoHS)	CU NIPDAU	N / A for Pkg Type	Purchase Samples

⁽¹⁾ The marketing status values are defined as follows:

ACTIVE: Product device recommended for new designs.

LIFEBUY: TI has announced that the device will be discontinued, and a lifetime-buy period is in effect.

NRND: Not recommended for new designs. Device is in production to support existing customers, but TI does not recommend using this part in a new design.

PREVIEW: Device has been announced but is not in production. Samples may or may not be available.

OBSELETE: TI has discontinued the production of the device.

⁽²⁾ Eco Plan - The planned eco-friendly classification: Pb-Free (RoHS), Pb-Free (RoHS Exempt), or Green (RoHS & no Sb/Br) - please check <http://www.ti.com/productcontent> for the latest availability information and additional product content details.

TBD: The Pb-Free/Green conversion plan has not been defined.

Pb-Free (RoHS): TI's terms "Lead-Free" or "Pb-Free" mean semiconductor products that are compatible with the current RoHS requirements for all 6 substances, including the requirement that lead not exceed 0.1% by weight in homogeneous materials. Where designed to be soldered at high temperatures, TI Pb-Free products are suitable for use in specified lead-free processes.

Pb-Free (RoHS Exempt): This component has a RoHS exemption for either 1) lead-based flip-chip solder bumps used between the die and package, or 2) lead-based die adhesive used between the die and leadframe. The component is otherwise considered Pb-Free (RoHS compatible) as defined above.

Green (RoHS & no Sb/Br): TI defines "Green" to mean Pb-Free (RoHS compatible), and free of Bromine (Br) and Antimony (Sb) based flame retardants (Br or Sb do not exceed 0.1% by weight in homogeneous material)

⁽³⁾ MSL, Peak Temp. -- The Moisture Sensitivity Level rating according to the JEDEC industry standard classifications, and peak solder temperature.

Important Information and Disclaimer: The information provided on this page represents TI's knowledge and belief as of the date that it is provided. TI bases its knowledge and belief on information provided by third parties, and makes no representation or warranty as to the accuracy of such information. Efforts are underway to better integrate information from third parties. TI has taken and continues to take reasonable steps to provide representative and accurate information but may not have conducted destructive testing or chemical analysis on incoming materials and chemicals. TI and TI suppliers consider certain information to be proprietary, and thus CAS numbers and other limited information may not be available for release.

In no event shall TI's liability arising out of such information exceed the total purchase price of the TI part(s) at issue in this document sold by TI to Customer on an annual basis.

N (R-PDIP-T**)

PLASTIC DUAL-IN-LINE PACKAGE

16 PINS SHOWN

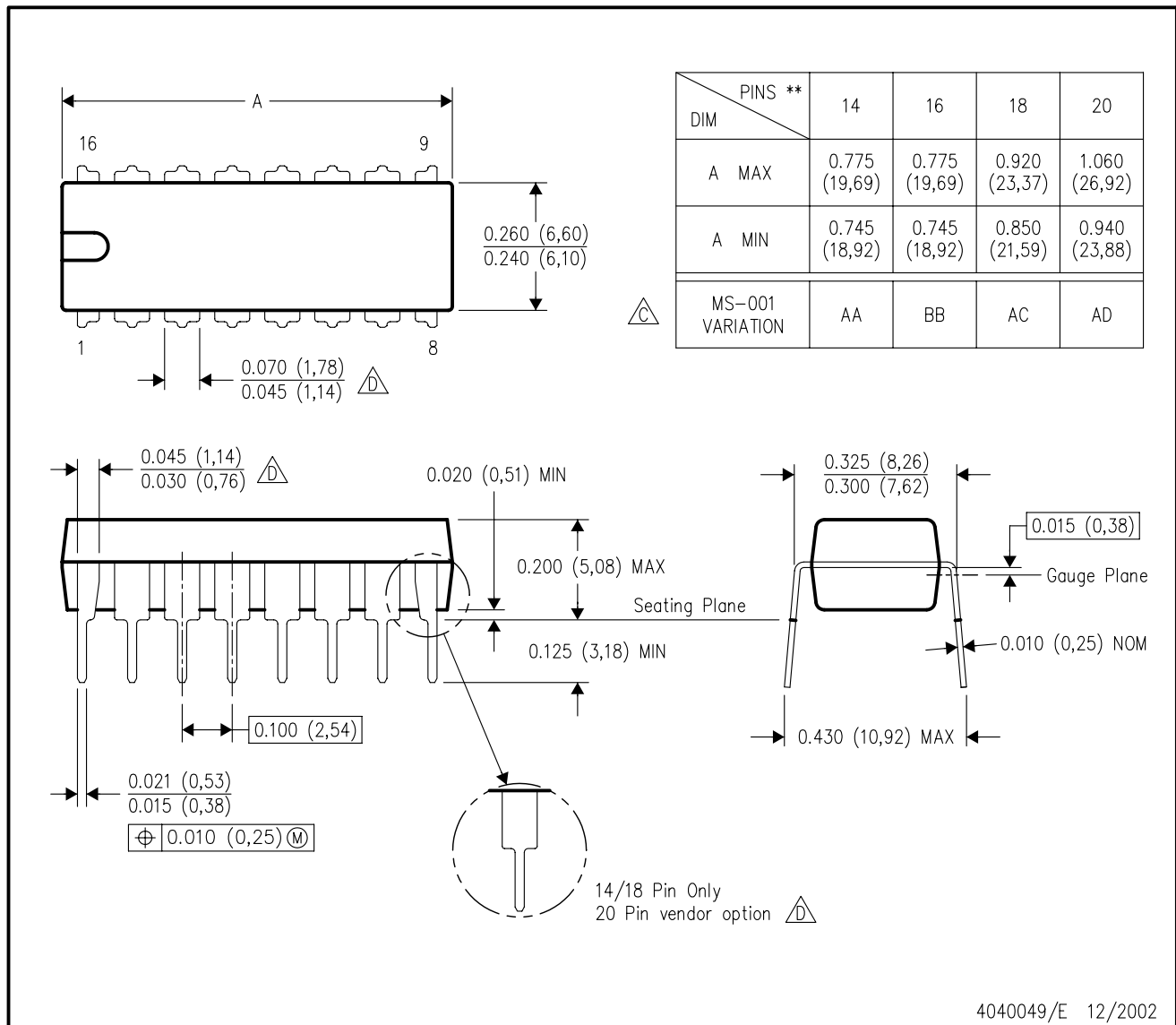

- NOTES:
- A. All linear dimensions are in inches (millimeters).
 - B. This drawing is subject to change without notice.
 - C Falls within JEDEC MS-001, except 18 and 20 pin minimum body length (Dim A).
 - D The 20 pin end lead shoulder width is a vendor option, either half or full width.

4040049/E 12/2002

DW (R-PDSO-G16)

PLASTIC SMALL OUTLINE

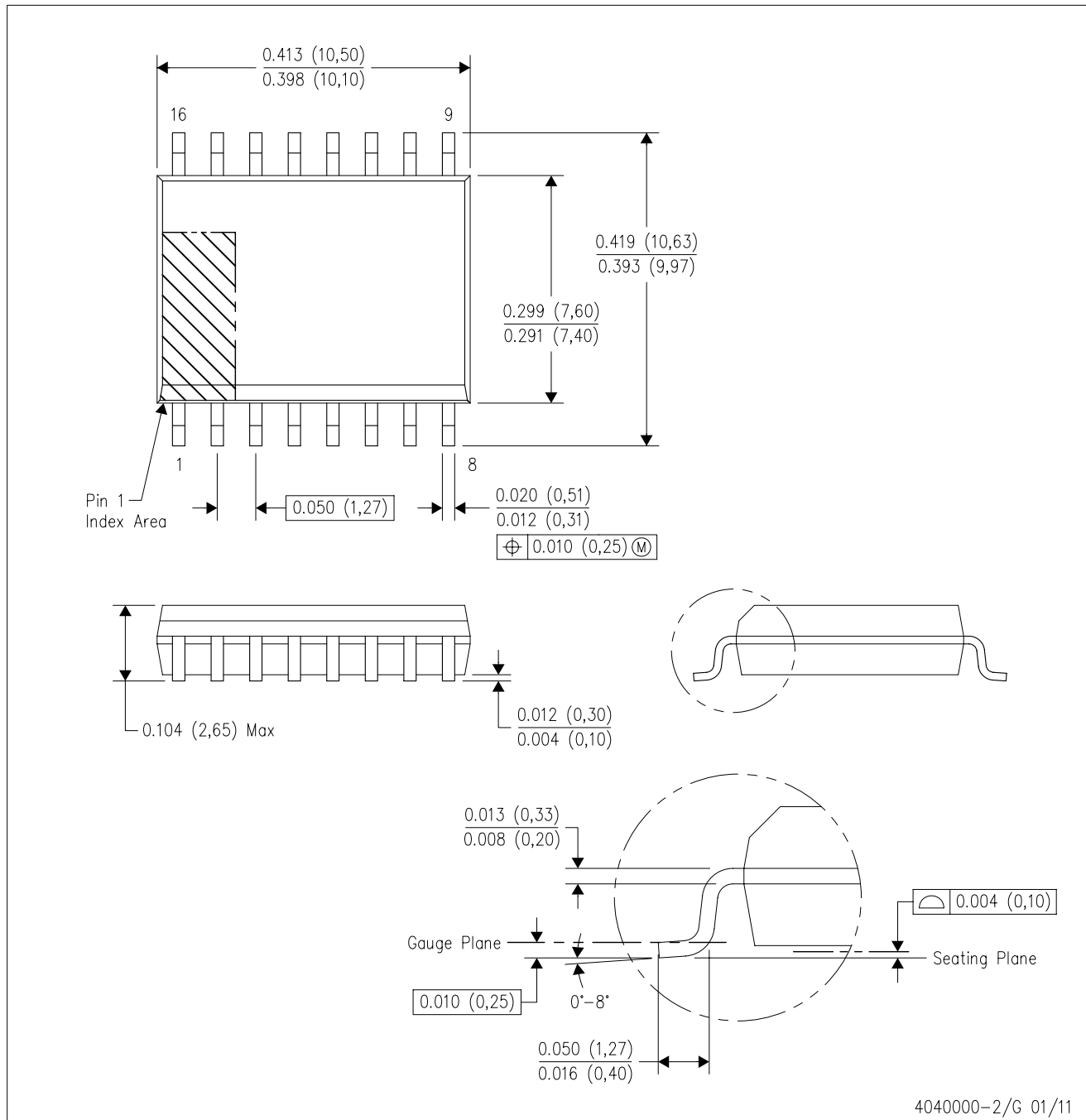

- NOTES:
- A. All linear dimensions are in inches (millimeters). Dimensioning and tolerancing per ASME Y14.5M-1994.
 - B. This drawing is subject to change without notice.
 - C. Body dimensions do not include mold flash or protrusion not to exceed 0.006 (0,15).
 - D. Falls within JEDEC MS-013 variation AA.

DW (R-PDSO-G16)

PLASTIC SMALL OUTLINE

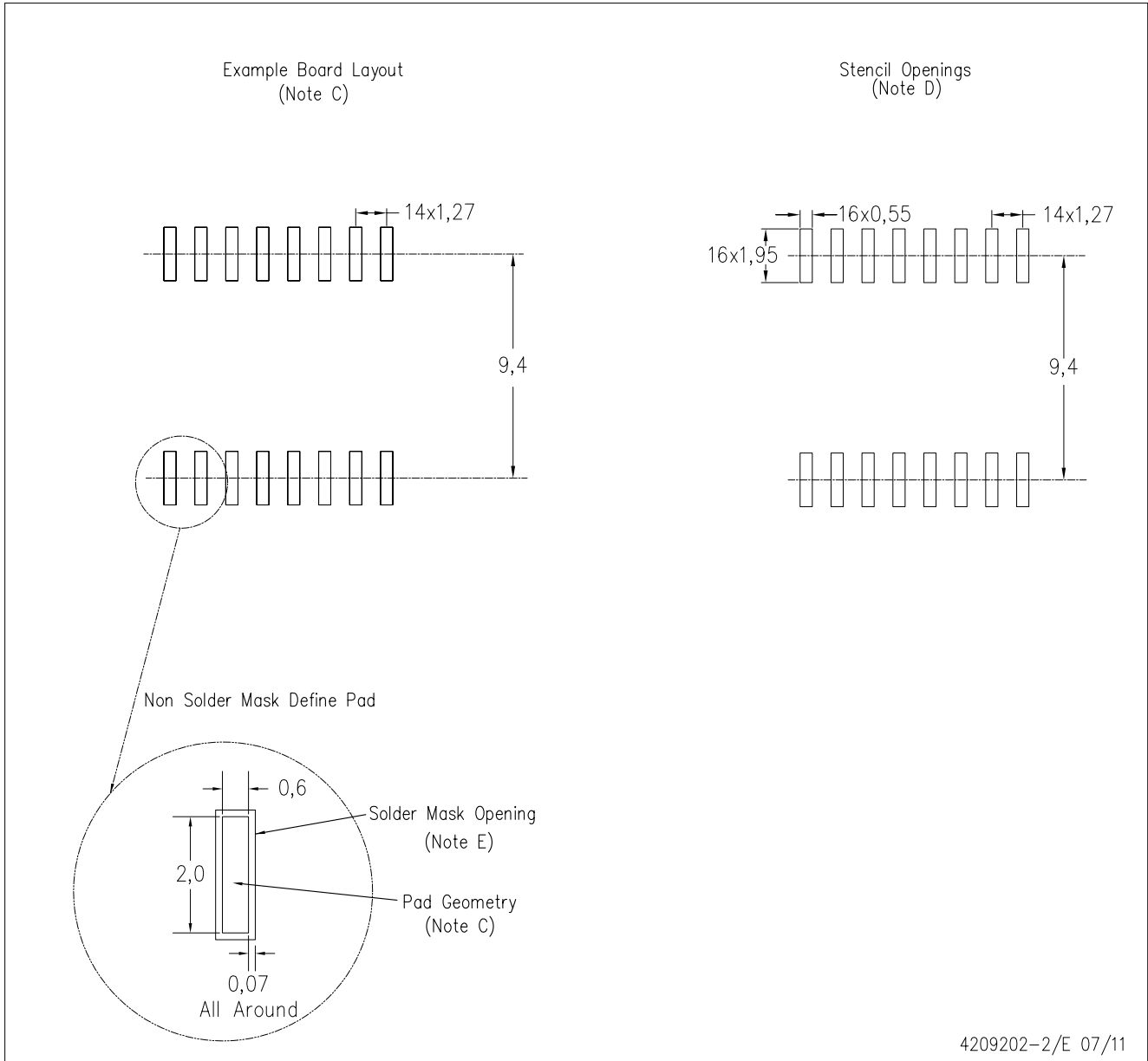

4209202-2/E 07/11

- NOTES:
- A. All linear dimensions are in millimeters.
 - B. This drawing is subject to change without notice.
 - C. Refer to IPC7351 for alternate board design.
 - D. Laser cutting apertures with trapezoidal walls and also rounding corners will offer better paste release. Customers should contact their board assembly site for stencil design recommendations. Refer to IPC-7525
 - E. Customers should contact their board fabrication site for solder mask tolerances between and around signal pads.

IMPORTANT NOTICE

Texas Instruments Incorporated and its subsidiaries (TI) reserve the right to make corrections, modifications, enhancements, improvements, and other changes to its products and services at any time and to discontinue any product or service without notice. Customers should obtain the latest relevant information before placing orders and should verify that such information is current and complete. All products are sold subject to TI's terms and conditions of sale supplied at the time of order acknowledgment.

TI warrants performance of its hardware products to the specifications applicable at the time of sale in accordance with TI's standard warranty. Testing and other quality control techniques are used to the extent TI deems necessary to support this warranty. Except where mandated by government requirements, testing of all parameters of each product is not necessarily performed.

TI assumes no liability for applications assistance or customer product design. Customers are responsible for their products and applications using TI components. To minimize the risks associated with customer products and applications, customers should provide adequate design and operating safeguards.

TI does not warrant or represent that any license, either express or implied, is granted under any TI patent right, copyright, mask work right, or other TI intellectual property right relating to any combination, machine, or process in which TI products or services are used. Information published by TI regarding third-party products or services does not constitute a license from TI to use such products or services or a warranty or endorsement thereof. Use of such information may require a license from a third party under the patents or other intellectual property of the third party, or a license from TI under the patents or other intellectual property of TI.

Reproduction of TI information in TI data books or data sheets is permissible only if reproduction is without alteration and is accompanied by all associated warranties, conditions, limitations, and notices. Reproduction of this information with alteration is an unfair and deceptive business practice. TI is not responsible or liable for such altered documentation. Information of third parties may be subject to additional restrictions.

Resale of TI products or services with statements different from or beyond the parameters stated by TI for that product or service voids all express and any implied warranties for the associated TI product or service and is an unfair and deceptive business practice. TI is not responsible or liable for any such statements.

TI products are not authorized for use in safety-critical applications (such as life support) where a failure of the TI product would reasonably be expected to cause severe personal injury or death, unless officers of the parties have executed an agreement specifically governing such use. Buyers represent that they have all necessary expertise in the safety and regulatory ramifications of their applications, and acknowledge and agree that they are solely responsible for all legal, regulatory and safety-related requirements concerning their products and any use of TI products in such safety-critical applications, notwithstanding any applications-related information or support that may be provided by TI. Further, Buyers must fully indemnify TI and its representatives against any damages arising out of the use of TI products in such safety-critical applications.

TI products are neither designed nor intended for use in military/aerospace applications or environments unless the TI products are specifically designated by TI as military-grade or "enhanced plastic." Only products designated by TI as military-grade meet military specifications. Buyers acknowledge and agree that any such use of TI products which TI has not designated as military-grade is solely at the Buyer's risk, and that they are solely responsible for compliance with all legal and regulatory requirements in connection with such use.

TI products are neither designed nor intended for use in automotive applications or environments unless the specific TI products are designated by TI as compliant with ISO/TS 16949 requirements. Buyers acknowledge and agree that, if they use any non-designated products in automotive applications, TI will not be responsible for any failure to meet such requirements.

Following are URLs where you can obtain information on other Texas Instruments products and application solutions:

Products

Audio	www.ti.com/audio
Amplifiers	amplifier.ti.com
Data Converters	dataconverter.ti.com
DLP® Products	www.dlp.com
DSP	dsp.ti.com
Clocks and Timers	www.ti.com/clocks
Interface	interface.ti.com
Logic	logic.ti.com
Power Mgmt	power.ti.com
Microcontrollers	microcontroller.ti.com
RFID	www.ti-rfid.com
RF/IF and ZigBee® Solutions	www.ti.com/lprf

Applications

Communications and Telecom	www.ti.com/communications
Computers and Peripherals	www.ti.com/computers
Consumer Electronics	www.ti.com/consumer-apps
Energy and Lighting	www.ti.com/energy
Industrial	www.ti.com/industrial
Medical	www.ti.com/medical
Security	www.ti.com/security
Space, Avionics and Defense	www.ti.com/space-avionics-defense
Transportation and Automotive	www.ti.com/automotive
Video and Imaging	www.ti.com/video
Wireless	www.ti.com/wireless-apps

TI E2E Community Home Page

e2e.ti.com

Mailing Address: Texas Instruments, Post Office Box 655303, Dallas, Texas 75265
Copyright © 2011, Texas Instruments Incorporated