

SN54LV74, SN74LV74 DUAL POSITIVE-EDGE-TRIGGERED D-TYPE FLIP-FLOPS

SCLS189C – FEBRUARY 1993 – REVISED APRIL 1996

- **EPIC™ (Enhanced-Performance Implanted CMOS) 2- μ Process**
- **Typical V_{OLP} (Output Ground Bounce) < 0.8 V at V_{CC} , $T_A = 25^\circ\text{C}$**
- **Typical V_{OHV} (Output V_{OH} Undershoot) > 2 V at V_{CC} , $T_A = 25^\circ\text{C}$**
- **ESD Protection Exceeds 2000 V Per MIL-STD-883C, Method 3015; Exceeds 200 V Using Machine Model ($C = 200$ pF, $R = 0$)**
- **Latch-Up Performance Exceeds 250 mA Per JEDEC Standard JESD-17**
- **Package Options Include Plastic Small-Outline (D), Shrink Small-Outline (DB), Thin Shrink Small-Outline (PW), Ceramic Flat (W) Packages, Chip Carriers (FK), and (J) 300-mil DIPs**

description

These dual positive-edge-triggered D-type flip-flops are designed for 2.7-V to 5.5-V V_{CC} operation.

A low level at the preset ($\overline{\text{PRE}}$) or clear ($\overline{\text{CLR}}$) inputs sets or resets the outputs regardless of the levels of the other inputs. When $\overline{\text{PRE}}$ and $\overline{\text{CLR}}$ are inactive (high), data at the data (D) inputs meeting the setup-time requirements is transferred to the outputs on the positive-going edge of the clock pulse. Clock triggering occurs at a voltage level and is not directly related to the rise time of the clock pulse. Following the hold-time interval, data at the D input can be changed without affecting the levels at the outputs.

The SN74LV74 is available in TI's shrink small-outline package (DB), which provides the same I/O pin count and functionality of standard small-outline packages in less than half the printed-circuit-board area.

The SN54LV74 is characterized for operation over the full military temperature range of -55°C to 125°C . The SN74LV74 is characterized for operation from -40°C to 85°C .

SN54LV74 . . . J OR W PACKAGE
SN74LV74 . . . D, DP, OR PW PACKAGE
(TOP VIEW)

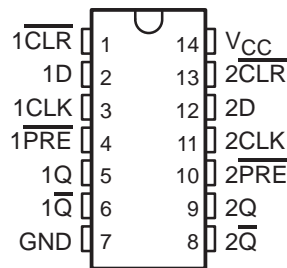

SN54LV74 . . . FK PACKAGE
(TOP VIEW)

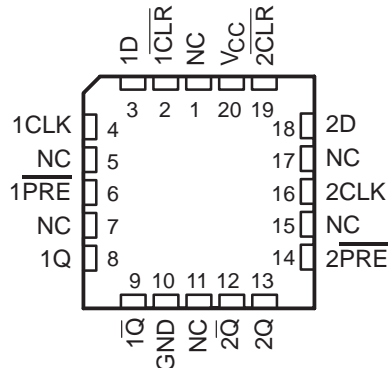

NC – No internal connection



Please be aware that an important notice concerning availability, standard warranty, and use in critical applications of Texas Instruments semiconductor products and disclaimers thereto appears at the end of this data sheet.

EPIC is a trademark of Texas Instruments Incorporated.

UNLESS OTHERWISE NOTED this document contains PRODUCTION DATA information current as of publication date. Products conform to specifications per the terms of Texas Instruments standard warranty. Production processing does not necessarily include testing of all parameters.

 **TEXAS
INSTRUMENTS**

POST OFFICE BOX 655303 • DALLAS, TEXAS 75265

Copyright © 1996, Texas Instruments Incorporated

SN54LV74, SN74LV74 DUAL POSITIVE-EDGE-TRIGGERED D-TYPE FLIP-FLOPS

SCLS189C – FEBRUARY 1993 – REVISED APRIL 1996

FUNCTION TABLE

INPUTS				OUTPUTS	
$\overline{\text{PRE}}$	$\overline{\text{CLR}}$	CLK	D	Q	$\overline{\text{Q}}$
L	H	X	X	H	L
H	L	X	X	L	H
L	L	X	X	H [†]	H [†]
H	H	↑	H	H	L
H	H	↑	L	L	H
H	H	L	X	Q ₀	$\overline{\text{Q}}_0$

† This configuration is nonstable; that is, it does not persist when $\overline{\text{PRE}}$ or $\overline{\text{CLR}}$ returns to its inactive (high) level.

logic symbol†

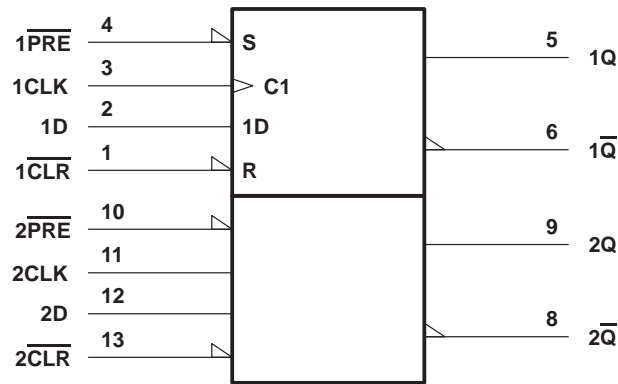

† This symbol is in accordance with ANSI/IEEE Std 91-1984 and IEC Publication 617-12. Pin numbers shown are for D, DB, J, PW, and W packages.

logic diagram, each flip-flop (positive logic)

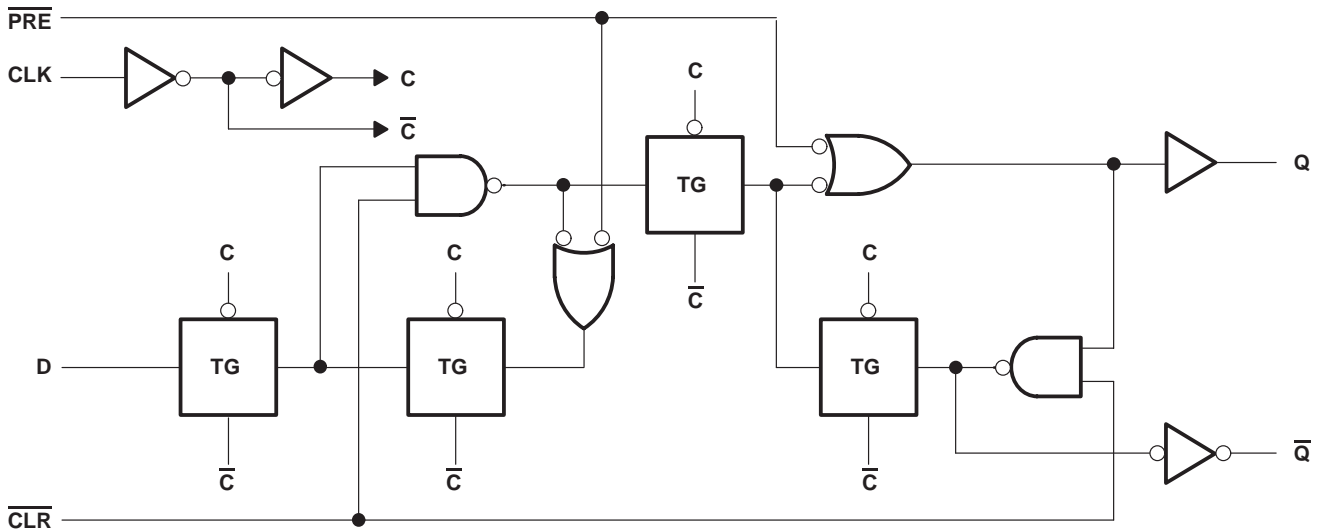

SN54LV74, SN74LV74

DUAL POSITIVE-EDGE-TRIGGERED D-TYPE FLIP-FLOPS

SCLS189C – FEBRUARY 1993 – REVISED APRIL 1996

absolute maximum ratings over operating free-air temperature range (unless otherwise noted)†

Supply voltage range, V_{CC}	–0.5 V to 7 V
Input voltage range, V_I (see Note 1)	–0.5 V to $V_{CC} + 0.5$ V
Output voltage range, V_O (see Notes 1 and 2)	–0.5 V to $V_{CC} + 0.5$ V
Input clamp current, I_{IK} ($V_I < 0$ or $V_I > V_{CC}$)	±20 mA
Output clamp current, I_{OK} ($V_O < 0$ or $V_O > V_{CC}$)	±50 mA
Continuous output current, I_O ($V_O = 0$ to V_{CC})	±25 mA
Continuous current through V_{CC} or GND	±50 mA
Maximum power dissipation at $T_A = 55^\circ\text{C}$ (in still air) (see Note 3): D package	1.25 W
DB or PW package	0.5 W
Storage temperature range, T_{stg}	–65°C to 150°C

† Stresses beyond those listed under “absolute maximum ratings” may cause permanent damage to the device. These are stress ratings only, and functional operation of the device at these or any other conditions beyond those indicated under “recommended operating conditions” is not implied. Exposure to absolute-maximum-rated conditions for extended periods may affect device reliability.

- NOTES: 1. The input and output voltage ratings may be exceeded if the input and output current ratings are observed.
 2. This value is limited to 7 V maximum.
 3. The maximum package power dissipation is calculated using a junction temperature of 150°C and a board trace length of 750 mils.

recommended operating conditions (see Note 4)

		SN54LV74		SN74LV74		UNIT UNIT
		MIN	MAX	MIN	MAX	
V_{CC}	Supply voltage	2.7	5.5	2.7	5.5	V
V_{IH}	High-level input voltage	$V_{CC} = 2.7$ V to 3.6 V		2		V
		$V_{CC} = 4.5$ V to 5.5 V		3.15		
V_{IL}	Low-level input voltage	$V_{CC} = 2.7$ V to 3.6 V		0.8		V
		$V_{CC} = 4.5$ V to 5.5 V		1.65		
V_I	Input voltage	0	V_{CC}	0	V_{CC}	V
V_O	Output voltage	0	V_{CC}	0	V_{CC}	V
I_{OH}	High-level output current	$V_{CC} = 2.7$ V to 3.6 V		–6		mA
		$V_{CC} = 4.5$ V to 5.5 V		–12		
I_{OL}	Low-level output current	$V_{CC} = 2.7$ V to 3.6 V		6		mA
		$V_{CC} = 4.5$ V to 5.5 V		12		
$\Delta t/\Delta v$	Input transition rise or fall rate	0	100	0	100	ns/V
T_A	Operating free-air temperature	–55	125	–40	85	°C

NOTE 4: Unused inputs must be held high or low to prevent them from floating.

SN54LV74, SN74LV74

DUAL POSITIVE-EDGE-TRIGGERED D-TYPE FLIP-FLOPS

SCLS189C – FEBRUARY 1993 – REVISED APRIL 1996

electrical characteristics over recommended operating free-air temperature range (unless otherwise noted)

PARAMETER	TEST CONDITIONS		V _{CC} †	SN54LV74			SN74LV74			UNIT
				MIN	TYP	MAX	MIN	TYP	MAX	
V _{OH}	I _{OH} = -100 μA		MIN to MAX	V _{CC} - 0.2			V _{CC} - 0.2			V
	I _{OH} = -6 mA		3 V	2.4			2.4			
	I _{OH} = -12 mA		4.5 V	3.6			3.6			
V _{OL}	I _{OL} = 100 μA		MIN to MAX	0.2			0.2			V
	I _{OL} = 6 mA		3 V	0.4			0.4			
	I _{OL} = 12 mA		4.5 V	0.55			0.55			
I _I	V _I = V _{CC} or GND		3.6 V	±1			±1			μA
			5.5 V	±1			±1			
I _{CC}	V _I = V _{CC} or GND	I _O = 0	3.6 V	20			20			μA
			5.5 V	20			20			
ΔI _{CC}	One input at V _{CC} - 0.6 V	Other inputs at V _{CC} or GND	3 V to 3.6 V			500			μA	
C _i	V _I = V _{CC} or GND		3.3 V	2.5			2.5			pF
			5 V	3			3			

† For conditions shown as MIN or MAX, use the appropriate values under recommended operating conditions.

timing requirements over recommended ranges of supply voltage and operating free-air temperature (unless otherwise noted)

			SN54LV74						UNIT
			V _{CC} = 5 V ± 0.5 V		V _{CC} = 3.3 V ± 0.3 V		V _{CC} = 2.7 V		
			MIN	MAX	MIN	MAX	MIN	MAX	
f _{clock}	Clock frequency		0	70	0	60	0	50	ns
t _w	Pulse duration, LE high	PRE or CLR low	15		20		25		ns
		CLK high or low	15		20		25		
t _{su}	Setup time, data before CLK↑	Data	6		8		12		ns
		PRE or CLR inactive	5		6		8		
t _h	Hold time, data after CLK↑		3		3		3		ns

timing requirements over recommended ranges of supply voltage and operating free-air temperature (unless otherwise noted)

			SN74LV74						UNIT
			V _{CC} = 5 V ± 0.5 V		V _{CC} = 3.3 V ± 0.3 V		V _{CC} = 2.7 V		
			MIN	MAX	MIN	MAX	MIN	MAX	
f _{clock}	Clock frequency		0	70	0	60	0	50	ns
t _w	Pulse duration, LE high	PRE or CLR low	15		20		25		ns
		CLK high or low	15		20		25		
t _{su}	Setup time, data before CLK↑	Data	6		8		12		ns
		PRE or CLR inactive	5		6		8		
t _h	Hold time, data after CLK↑		3		3		3		ns

PRODUCT PREVIEW information concerns products in the formative or design phase of development. Characteristic data and other specifications are design goals. Texas Instruments reserves the right to change or discontinue these products without notice.



POST OFFICE BOX 655303 • DALLAS, TEXAS 75265

SN54LV74, SN74LV74

DUAL POSITIVE-EDGE-TRIGGERED D-TYPE FLIP-FLOPS

SCLS189C – FEBRUARY 1993 – REVISED APRIL 1996

switching characteristics over recommended operating free-air temperature range, $C_L = 50 \text{ pF}$ (unless otherwise noted) (see Figure 1)

PARAMETER	FROM (INPUT)	TO (OUTPUT)	SN54LV74						UNIT		
			$V_{CC} = 5 \text{ V} \pm 0.5 \text{ V}$			$V_{CC} = 3.3 \text{ V} \pm 0.3 \text{ V}$				$V_{CC} = 2.7 \text{ V}$	
			MIN	TYP	MAX	MIN	TYP	MAX		MIN	MAX
f_{max}			70	100		60	90		50	MHz	
t_{pd}	$\overline{\text{PRE}}$ or $\overline{\text{CLR}}$	Q or \overline{Q}		11	19		18	27		34	ns
	CLK			10	17		17	26		28	

switching characteristics over recommended operating free-air temperature range, $C_L = 50 \text{ pF}$ (unless otherwise noted) (see Figure 1)

PARAMETER	FROM (INPUT)	TO (OUTPUT)	SN74LV74						UNIT		
			$V_{CC} = 5 \text{ V} \pm 0.5 \text{ V}$			$V_{CC} = 3.3 \text{ V} \pm 0.3 \text{ V}$				$V_{CC} = 2.7 \text{ V}$	
			MIN	TYP	MAX	MIN	TYP	MAX		MIN	MAX
f_{max}			70	100		60	90		50	MHz	
t_{pd}	$\overline{\text{PRE}}$ or $\overline{\text{CLR}}$	Q or \overline{Q}		11	19		18	27		34	ns
	CLK			10	17		17	26		28	

operating characteristics, $T_A = 25^\circ\text{C}$

PARAMETER		TEST CONDITIONS	V_{CC}	TYP	UNIT
C_{pd}	Power dissipation capacitance per flip-flop	$C_L = 50 \text{ pF}$, $f = 10 \text{ MHz}$	3.3 V	32	pF
			5 V	68	

PRODUCT PREVIEW information concerns products in the formative or design phase of development. Characteristic data and other specifications are design goals. Texas Instruments reserves the right to change or discontinue these products without notice.



SN54LV74, SN74LV74 DUAL POSITIVE-EDGE-TRIGGERED D-TYPE FLIP-FLOPS

SCLS189C – FEBRUARY 1993 – REVISED APRIL 1996

PARAMETER MEASUREMENT INFORMATION

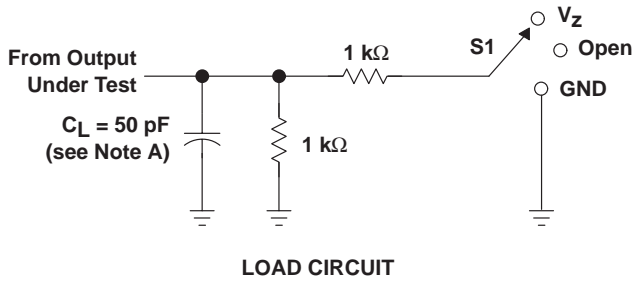

TEST	S1
t _{PLH} /t _{PHL}	Open
t _{PLZ} /t _{PZL}	V _Z
t _{PHZ} /t _{PZH}	GND

WAVEFORM CONDITION	V _{CC} = 4.5 V to 5.5 V	V _{CC} = 2.7 V to 3.6 V
V _m	0.5 × V _{CC}	1.5 V
V _i	V _{CC}	2.7 V
V _Z	2 × V _{CC}	6 V

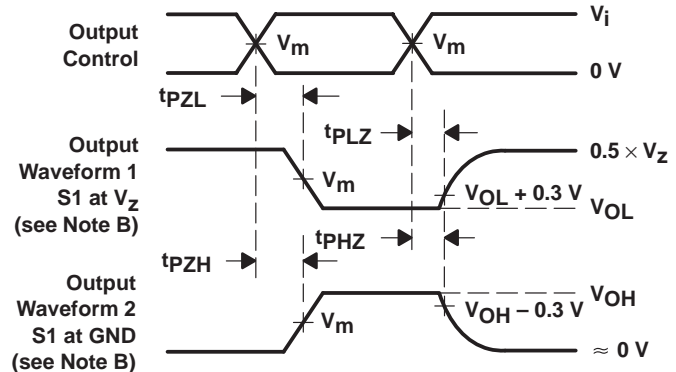
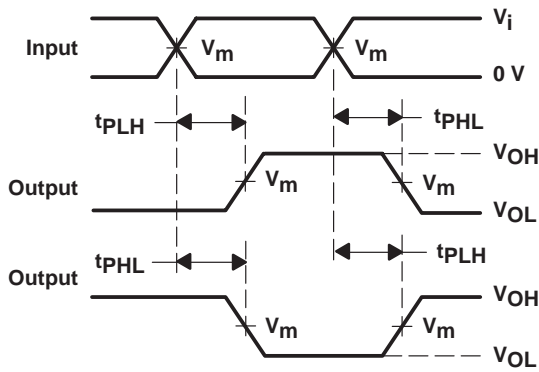
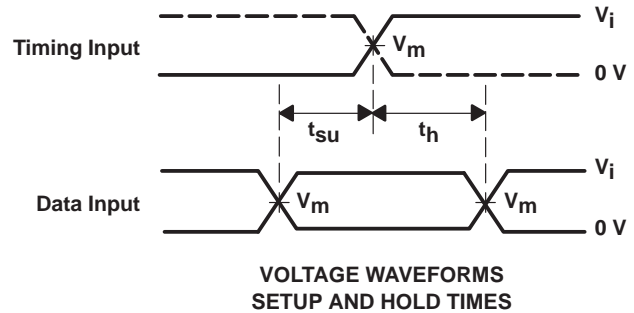
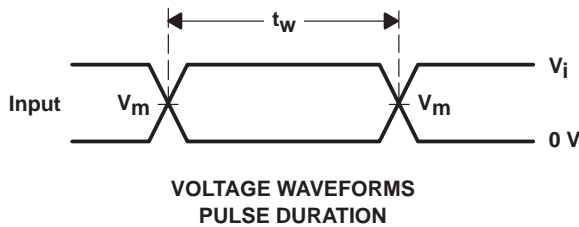

- NOTES:
- C_L includes probe and jig capacitance.
 - Waveform 1 is for an output with internal conditions such that the output is low except when disabled by the output control. Waveform 2 is for an output with internal conditions such that the output is high except when disabled by the output control.
 - All input pulses are supplied by generators having the following characteristics: PRR ≤ 10 MHz, Z_O = 50 Ω, t_r ≤ 2.5 ns, t_f ≤ 2.5 ns.
 - The outputs are measured one at a time with one transition per measurement.
 - t_{PLZ} and t_{PHZ} are the same as t_{dis}.
 - t_{PZL} and t_{PZH} are the same as t_{en}.
 - t_{PLH} and t_{PHL} are the same as t_{pd}.

Figure 1. Load Circuit and Voltage Waveforms

IMPORTANT NOTICE

Texas Instruments and its subsidiaries (TI) reserve the right to make changes to their products or to discontinue any product or service without notice, and advise customers to obtain the latest version of relevant information to verify, before placing orders, that information being relied on is current and complete. All products are sold subject to the terms and conditions of sale supplied at the time of order acknowledgement, including those pertaining to warranty, patent infringement, and limitation of liability.

TI warrants performance of its semiconductor products to the specifications applicable at the time of sale in accordance with TI's standard warranty. Testing and other quality control techniques are utilized to the extent TI deems necessary to support this warranty. Specific testing of all parameters of each device is not necessarily performed, except those mandated by government requirements.

CERTAIN APPLICATIONS USING SEMICONDUCTOR PRODUCTS MAY INVOLVE POTENTIAL RISKS OF DEATH, PERSONAL INJURY, OR SEVERE PROPERTY OR ENVIRONMENTAL DAMAGE ("CRITICAL APPLICATIONS"). TI SEMICONDUCTOR PRODUCTS ARE NOT DESIGNED, AUTHORIZED, OR WARRANTED TO BE SUITABLE FOR USE IN LIFE-SUPPORT DEVICES OR SYSTEMS OR OTHER CRITICAL APPLICATIONS. INCLUSION OF TI PRODUCTS IN SUCH APPLICATIONS IS UNDERSTOOD TO BE FULLY AT THE CUSTOMER'S RISK.

In order to minimize risks associated with the customer's applications, adequate design and operating safeguards must be provided by the customer to minimize inherent or procedural hazards.

TI assumes no liability for applications assistance or customer product design. TI does not warrant or represent that any license, either express or implied, is granted under any patent right, copyright, mask work right, or other intellectual property right of TI covering or relating to any combination, machine, or process in which such semiconductor products or services might be or are used. TI's publication of information regarding any third party's products or services does not constitute TI's approval, warranty or endorsement thereof.