

# SN74LVC2T45 Dual-Bit Dual-Supply Bus Transceiver

## With Configurable Voltage Translation

### 1 Features

- Fully configurable dual-rail design allows each port to operate over the full 1.65-V to 5.5-V power-supply range
- $V_{CC}$  isolation feature – if either  $V_{CC}$  input is at GND, both ports are in the high-impedance state
- DIR input circuit referenced to  $V_{CCA}$
- Low power consumption, 4- $\mu$ A maximum  $I_{CC}$
- Available in the Texas Instruments NanoFree™ package
- $\pm 24$ -mA output drive at 3.3 V
- $I_{off}$  supports Partial-Power-Down mode operation
- Maximum data rates:
  - 420 Mbps (3.3-V to 5-V translation)
  - 210 Mbps (translate to 3.3 V)
  - 140 Mbps (translate to 2.5 V)
  - 75 Mbps (translate to 1.8 V)
- Latch-up performance exceeds 100 mA per JESD 78, Class II
- ESD protection exceeds JESD 22
  - 4000-V Human-Body Model (A114-A)
  - 200-V Machine Model (A115-A)
  - 1000-V Charged-Device Model (C101)

### 2 Applications

- [Personal electronic](#)
- [Industrial](#)
- [Enterprise](#)
- [Telecom](#)

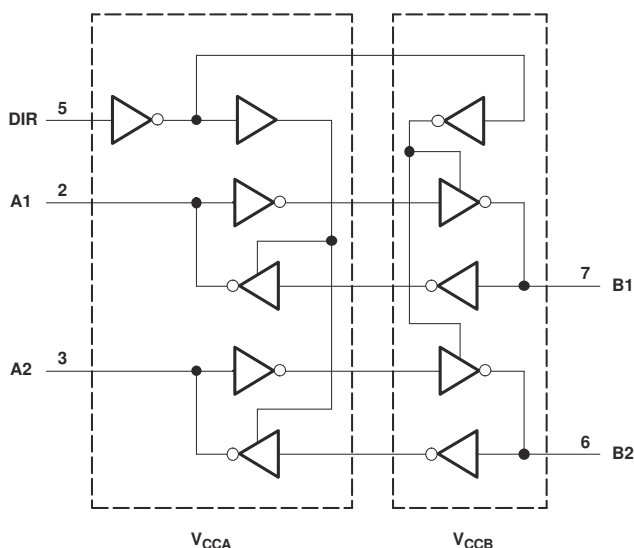

**Functional Block Diagram**

### 3 Description

This dual-bit noninverting bus transceiver uses two separate configurable power-supply rails. The A port is designed to track  $V_{CCA}$ .  $V_{CCA}$  accepts any supply voltage from 1.65V to 5.5V. The B port is designed to track  $V_{CCB}$ .  $V_{CCB}$  accepts any supply voltage from 1.65V to 5.5V. This allows for universal low-voltage bidirectional translation between any of the 1.8V, 2.5V, 3.3V, and 5V voltage nodes.

The SN74LVC2T45 is designed for asynchronous communication between two data buses. The logic levels of the direction-control (DIR) input activate either the B-port outputs or the A-port outputs. The device transmits data from the A bus to the B bus when the B-port outputs are activated, and from the B bus to the A bus when the A-port outputs are activated. The input circuitry on both A and B ports are always active and must have a logic HIGH or LOW level applied to prevent excess  $I_{CC}$  and  $I_{CCZ}$ .

The SN74LVC2T45 is designed so that  $V_{CCA}$  supplies the DIR input circuit. This device is fully specified for partial-power-down applications using  $I_{off}$ . The  $I_{off}$  circuitry disables the outputs, preventing damaging current backflow through the device when it is powered down.

The  $V_{CC}$  isolation feature is designed so that if either  $V_{CC}$  input is at GND, both ports are in the high-impedance state.

#### Package Information

| PART NUMBER | PACKAGE <sup>(1)</sup> | PACKAGE SIZE <sup>(2)</sup> |
|-------------|------------------------|-----------------------------|
| SN74LVC2T45 | DCT (SM8, 8)           | 2.95mm × 4mm                |
|             | DCU (VSSOP, 8)         | 2mm × 3.1mm                 |
|             | YZP (DSBGA, 8)         | 1.5mm × 0.5mm               |

(1) For more information, see [Section 11](#).

(2) The package size (length × width) is a nominal value and includes pins, where applicable.



## Table of Contents

|   |    |  |    |
|---|----|--|----|
| <b>1 Features</b> .....   | 1  | 7.2 Functional Block Diagram.....                                | 14 |
| <b>2 Applications</b> .....                                     | 1  | 7.3 Feature Description.....                                     | 14 |
| <b>3 Description</b> .....                                      | 1  | 7.4 Device Functional Modes.....                                 | 15 |
| <b>4 Pin Configuration and Functions</b> .....                  | 2  | <b>8 Application and Implementation</b> .....                    | 16 |
| <b>5 Specifications</b> .....                                   | 4  | 8.1 Application Information.....                                 | 16 |
| 5.1 Absolute Maximum Ratings.....                               | 4  | 8.2 Typical Applications.....                                    | 16 |
| 5.2 ESD Ratings.....  | 4  | 8.3 Power Supply Recommendations.....                            | 19 |
| 5.3 Recommended Operating Conditions.....                       | 4  | 8.4 Layout.....  | 19 |
| 5.4 Thermal Information.....                                    | 5  | <b>9 Device and Documentation Support</b> .....                  | 21 |
| 5.5 Electrical Characteristics.....                             | 6  | 9.1 Documentation Support.....                                   | 21 |
| 5.6 Switching Characteristics: $V_{CCA} = 1.8V \pm 0.15V$ ..... | 7  | 9.2 Receiving Notification of Documentation Updates.....         | 21 |
| 5.7 Switching Characteristics: $V_{CCA} = 2.5V \pm 0.2V$ .....  | 7  | 9.3 Support Resources.....                                       | 21 |
| 5.8 Switching Characteristics: $V_{CCA} = 3.3V \pm 0.3V$ .....  | 8  | 9.4 Trademarks.....  | 21 |
| 5.9 Switching Characteristics: $V_{CCA} = 5V \pm 0.5V$ .....    | 8  | 9.5 Electrostatic Discharge Caution.....                         | 21 |
| 5.10 Operating Characteristics.....                             | 9  | 9.6 Glossary.....  | 21 |
| 5.11 Typical Characteristics.....                               | 10 | <b>10 Revision History</b> .....                                 | 21 |
| <b>6 Parameter Measurement Information</b> .....                | 13 | <b>11 Mechanical, Packaging, and Orderable Information</b> ..... | 21 |
| <b>7 Detailed Description</b> .....                             | 14 |  |    |
| 7.1 Overview.....   | 14 |  |    |

## 4 Pin Configuration and Functions

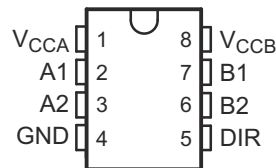
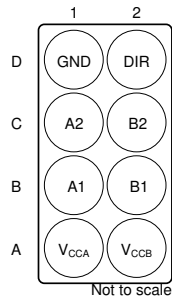

Figure 4-1. DCT or DCU Package, 8-Pin SM8 or VSSOP (Top View)

Table 4-1. Pin Functions: DCT, DCU

| PIN       |     | TYPE <sup>(1)</sup> | DESCRIPTION   |
|-----------|-----|---------------------|---|
| NAME      | NO. |                     |   |
| $V_{CCA}$ | 1   | P                   | A-port supply voltage. $1.65V \leq V_{CCA} \leq 5.5V$ |
| A1        | 2   | I/O                 | Input/output A1. Referenced to $V_{CCA}$              |
| A2        | 3   | I/O                 | Input/output A2. Referenced to $V_{CCA}$              |
| GND       | 4   | G                   | Ground  |
| DIR       | 5   | I                   | Direction control signal                              |
| B2        | 6   | I/O                 | Input/output B2. Referenced to $V_{CCB}$              |
| B1        | 7   | I/O                 | Input/output B1. Referenced to $V_{CCB}$              |
| $V_{CCB}$ | 8   | P                   | B-port supply voltage. $1.65V \leq V_{CCB} \leq 5.5V$ |

(1) I = input, O = output, P = power, G = ground



**Figure 4-2. YZP Package, 8-Pin DSGBA (Bottom View)**

**Table 4-2. Pin Functions: YZP**

| PIN |                  | TYPE <sup>(1)</sup> | DESCRIPTION   |
|-----|------------------|---------------------|---|
| NO. | NAME             |                     |   |
| A1  | V <sub>CCA</sub> | P                   | A-port supply voltage. $1.65V \leq V_{CCA} \leq 5.5V$ |
| A2  | V <sub>CCB</sub> | P                   | B-port supply voltage. $1.65V \leq V_{CCB} \leq 5.5V$ |
| B1  | A1               | I/O                 | Input/output A1. Referenced to V <sub>CCA</sub>       |
| B2  | B1               | I/O                 | Input/output B1. Referenced to V <sub>CCB</sub>       |
| C1  | A2               | I/O                 | Input/output A2. Referenced to V <sub>CCA</sub>       |
| C2  | B2               | I/O                 | Input/output B2. Referenced to V <sub>CCB</sub>       |
| D1  | GND              | G                   | Ground  |
| D2  | DIR              | I                   | Direction control signal                              |

(1) I = input, O = output, P = power, G = ground

## 5 Specifications

### 5.1 Absolute Maximum Ratings

 over operating free-air temperature range (unless otherwise noted)<sup>(1)</sup>

|                  |   | MIN                | MAX                    | UNIT |
|------------------|---|--------------------|------------------------|------|
| V <sub>CCA</sub> | Supply voltage  | -0.5               | 6.5                    | V    |
| V <sub>CCB</sub> |   |                    |                        |      |
| V <sub>I</sub>   | Input voltage <sup>(2)</sup>  | -0.5               | 6.5                    | V    |
| V <sub>O</sub>   | Voltage range applied to any output in the high-impedance or power-off state <sup>(2)</sup> | -0.5               | 6.5                    | V    |
| V <sub>O</sub>   | Voltage range applied to any output in the high or low state <sup>(2) (3)</sup>             | A port             | V <sub>CCA</sub> + 0.5 | V    |
|                  |   | B port             | V <sub>CCB</sub> + 0.5 |      |
| I <sub>IK</sub>  | Input clamp current   | V <sub>I</sub> < 0 | -50                    | mA   |
| I <sub>OK</sub>  | Output clamp current  | V <sub>O</sub> < 0 | -50                    | mA   |
| I <sub>O</sub>   | Continuous output current   | -50                | 50                     | mA   |
|                  | Continuous current through V <sub>CC</sub> or GND   | -100               | 100                    | mA   |
| T <sub>J</sub>   | Junction temperature  |                    | 150                    | °C   |
| T <sub>stg</sub> | Storage temperature   | -65                | 150                    | °C   |

- (1) Stresses beyond those listed under *Absolute Maximum Ratings* may cause permanent damage to the device. These are stress ratings only, which do not imply functional operation of the device at these or any other conditions beyond those indicated under *Recommended Operating Conditions*. Exposure to absolute-maximum-rated conditions for extended periods may affect device reliability.
- (2) The input and output negative-voltage ratings may be exceeded if the input and output clamp-current ratings are observed.
- (3) The value of V<sub>CC</sub> is provided in the *Recommended Operating Conditions* table.

### 5.2 ESD Ratings

|                    |                         | VALUE   | UNIT  |
|--------------------|-------------------------|---|-------|
| V <sub>(ESD)</sub> | Electrostatic discharge | Human body model (HBM), per ANSI/ESDA/JEDEC JS-001 <sup>1</sup>     | ±4000 |
|                    |                         | Charged device model (CDM), per ANSI/ESDA/JEDEC JS-002 <sup>2</sup> | ±1000 |

- (1) JEDEC document JEP155 states that 500V HBM allows safe manufacturing with a standard ESD control process.
- (2) JEDEC document JEP157 states that 250V CDM allows safe manufacturing with a standard ESD control process.

### 5.3 Recommended Operating Conditions

 over operating free-air temperature range (unless otherwise noted)<sup>(1) (2) (3)</sup>

|                  |                          | V <sub>CCI</sub>                                     | V <sub>CCO</sub> | MIN                     | MAX | UNIT |
|------------------|--------------------------|--|------------------|-------------------------|-----|------|
| V <sub>CCA</sub> | Supply voltage           |  |                  | 1.65                    | 5.5 | V    |
| V <sub>CCB</sub> |                          |  |                  | 1.65                    | 5.5 |      |
| V <sub>IH</sub>  | High-level input voltage | Data inputs <sup>(4)</sup>                           | 1.65V to 1.95V   | V <sub>CCI</sub> × 0.65 |     | V    |
|                  |                          |  | 2.3V to 2.7V     | 1.7                     |     |      |
|                  |                          |  | 3V to 3.6V       | 2                       |     |      |
|                  |                          |  | 4.5V to 5.5V     | V <sub>CCI</sub> × 0.7  |     |      |
| V <sub>IL</sub>  | Low-level input voltage  | Data inputs <sup>(4)</sup>                           | 1.65V to 1.95V   | V <sub>CCI</sub> × 0.35 |     | V    |
|                  |                          |  | 2.3V to 2.7V     | 0.7                     |     |      |
|                  |                          |  | 3V to 3.6V       | 0.8                     |     |      |
|                  |                          |  | 4.5V to 5.5V     | V <sub>CCI</sub> × 0.3  |     |      |
| V <sub>IH</sub>  | High-level input voltage | DIR (referenced to V <sub>CCA</sub> ) <sup>(5)</sup> | 1.65V to 1.95V   | V <sub>CCA</sub> × 0.65 |     | V    |
|                  |                          |  | 2.3V to 2.7V     | 1.7                     |     |      |
|                  |                          |  | 3V to 3.6V       | 2                       |     |      |
|                  |                          |  | 4.5V to 5.5V     | V <sub>CCA</sub> × 0.7  |     |      |

### 5.3 Recommended Operating Conditions (continued)

over operating free-air temperature range (unless otherwise noted)<sup>(1) (2) (3)</sup>

|                 |                                    |  | V <sub>CCI</sub> | V <sub>CCO</sub> | MIN              | MAX                     | UNIT |
|-----------------|------------------------------------|--|------------------|------------------|------------------|-------------------------|------|
| V <sub>IL</sub> | Low-level input voltage            | DIR (referenced to V <sub>CCA</sub> ) <sup>(5)</sup> | 1.65V to 1.95V   |                  |                  | V <sub>CCA</sub> × 0.35 | V    |
|                 |                                    |  | 2.3V to 2.7V     |                  |                  | 0.7                     |      |
|                 |                                    |  | 3V to 3.6V       |                  |                  | 0.8                     |      |
|                 |                                    |  | 4.5V to 5.5V     |                  |                  | V <sub>CCA</sub> × 0.3  |      |
| V <sub>I</sub>  | Input voltage                      |  |                  | 0                | 5.5              | V                       |      |
| V <sub>O</sub>  | Output voltage                     |  |                  | 0                | V <sub>CCO</sub> | V                       |      |
| I <sub>OH</sub> | High-level output current          |  | 1.65V to 1.95V   |                  |                  | –4                      | mA   |
|                 |                                    |  | 2.3V to 2.7V     |                  |                  | –8                      |      |
|                 |                                    |  | 3V to 3.6V       |                  |                  | –24                     |      |
|                 |                                    |  | 4.5V to 5.5V     |                  |                  | –32                     |      |
| I <sub>OL</sub> | Low-level output current           |  | 1.65V to 1.95V   |                  |                  | 4                       | mA   |
|                 |                                    |  | 2.3V to 2.7V     |                  |                  | 8                       |      |
|                 |                                    |  | 3V to 3.6V       |                  |                  | 24                      |      |
|                 |                                    |  | 4.5V to 5.5V     |                  |                  | 32                      |      |
| Δt/Δv           | Input transition rise or fall rate | Data inputs  | 1.65V to 1.95V   |                  |                  | 20                      | ns/V |
|                 |                                    |  | 2.3V to 2.7V     |                  |                  | 20                      |      |
|                 |                                    |  | 3V to 3.6V       |                  |                  | 10                      |      |
|                 |                                    |  | 4.5V to 5.5V     |                  |                  | 5                       |      |
|                 |                                    | Control input  | 1.65V to 5.5V    |                  |                  | 5                       |      |
| T <sub>A</sub>  | Operating free-air temperature     |  |                  | –40              | 85               | °C                      |      |

- (1) V<sub>CCI</sub> is the V<sub>CC</sub> associated with the input port.
- (2) V<sub>CCO</sub> is the V<sub>CC</sub> associated with the output port.
- (3) All unused data inputs of the device must be held at V<sub>CCI</sub> or GND for proper device operation. See [Implications of Slow or Floating CMOS Inputs](#), SCBA004.
- (4) For V<sub>CCI</sub> values not specified in the data sheet, V<sub>IH</sub> min = V<sub>CCI</sub> × 0.7V, V<sub>IL</sub> max = V<sub>CCI</sub> × 0.3V.
- (5) For V<sub>CCO</sub> values not specified in the data sheet, V<sub>IH</sub> min = V<sub>CCA</sub> × 0.7V, V<sub>IL</sub> max = V<sub>CCA</sub> × 0.3V.

### 5.4 Thermal Information

| THERMAL METRIC <sup>(1)</sup> |  | SN74LVC2T45 |       |       | UNIT |
|-------------------------------|--|-------------|-------|-------|------|
|                               |  | DCU         | DCT   | YZP   |      |
|                               |  | 8 PINS      |       |       |      |
| R <sub>θJA</sub>              | Junction-to-ambient thermal resistance       | 246.4       | 195.3 | 105.8 | °C/W |
| R <sub>θJC(top)</sub>         | Junction-to-case (top) thermal resistance    | 95.4        | 106   | 1.6   | °C/W |
| R <sub>θJB</sub>              | Junction-to-board thermal resistance         | 157.8       | 110.8 | 10.8  | °C/W |
| Ψ <sub>JT</sub>               | Junction-to-top characterization parameter   | 37          | 38.3  | 3.1   | °C/W |
| Ψ <sub>JB</sub>               | Junction-to-board characterization parameter | 156.9       | 109.3 | 10.8  | °C/W |

- (1) For more information about traditional and new thermal metrics, see the [Semiconductor and IC Package Thermal Metrics](#) application report.

## 5.5 Electrical Characteristics

over recommended operating free-air temperature range (unless otherwise noted)<sup>1 2</sup>

| PARAMETER  | TEST CONDITIONS  |  | V <sub>CCA</sub> | V <sub>CCB</sub> | T <sub>A</sub> = 25°C |     |     | -40°C to +85°C         |     | UNIT |
|--|--|--|------------------|------------------|-----------------------|-----|-----|------------------------|-----|------|
|  |  |  |                  |                  | MIN                   | TYP | MAX | MIN                    | MAX |      |
| V <sub>OH</sub>  | I <sub>OH</sub> = -100μA                                     |  | 1.65V to 4.5V    | 1.65V to 4.5V    |                       |     |     | V <sub>CCO</sub> - 0.1 |     | V    |
|  | I <sub>OH</sub> = -4mA                                       |  | 1.65V            | 1.65V            |                       |     |     | 1.2                    |     |      |
|  | I <sub>OH</sub> = -8mA                                       |  | 2.3V             | 2.3V             |                       |     |     | 1.9                    |     |      |
|  | I <sub>OH</sub> = -24mA                                      |  | 3V               | 3V               |                       |     |     | 2.4                    |     |      |
|  | I <sub>OH</sub> = -32mA                                      |  | 4.5V             | 4.5V             |                       |     |     | 3.8                    |     |      |
| V <sub>OL</sub>  | I <sub>OL</sub> = 100μA                                      |  | 1.65V to 4.5V    | 1.65V to 4.5V    |                       |     |     | 0.1                    |     | V    |
|  | I <sub>OL</sub> = 4mA  |  | 1.65V            | 1.65V            |                       |     |     | 0.45                   |     |      |
|  | I <sub>OL</sub> = 8mA  |  | 2.3V             | 2.3V             |                       |     |     | 0.3                    |     |      |
|  | I <sub>OL</sub> = 24mA                                       |  | 3V               | 3V               |                       |     |     | 0.55                   |     |      |
|  | I <sub>OL</sub> = 32mA                                       |  | 4.5V             | 4.5V             |                       |     |     | 0.55                   |     |      |
| I <sub>I</sub>   | DIR  | V <sub>I</sub> = V <sub>CCA</sub> or GND   | 1.65V to 5.5V    | 1.65V to 5.5V    |                       |     |     | ±1                     | ±2  | μA   |
| I <sub>off</sub>                                       | A port   | V <sub>I</sub> or V <sub>O</sub> = 0 to 5.5V   | 0V               | 0 to 5.5V        |                       |     |     | ±1                     | ±2  | μA   |
|  | B port   |  | 0 to 5.5V        | 0V               |                       |     |     | ±1                     | ±2  |      |
| I <sub>OZ</sub>  | A or B port  | V <sub>O</sub> = V <sub>CCO</sub> or GND   | 1.65V to 5.5V    | 1.65V to 5.5V    |                       |     |     | ±1                     | ±2  | μA   |
| I <sub>CCA</sub>                                       | V <sub>I</sub> = V <sub>CCI</sub> or GND, I <sub>O</sub> = 0 |  | 1.65V to 5.5V    | 1.65V to 5.5V    |                       |     |     |                        | 3   | μA   |
|  |  |  | 5V               | 0V               |                       |     |     |                        | 2   |      |
|  |  |  | 0V               | 5V               |                       |     |     |                        | -2  |      |
| I <sub>CCB</sub>                                       | V <sub>I</sub> = V <sub>CCI</sub> or GND, I <sub>O</sub> = 0 |  | 1.65V to 5.5V    | 1.65V to 5.5V    |                       |     |     |                        | 3   | μA   |
|  |  |  | 5V               | 0V               |                       |     |     |                        | -2  |      |
|  |  |  | 0V               | 5V               |                       |     |     |                        | 2   |      |
| I <sub>CCA</sub> + I <sub>CCB</sub><br>(see Table 8-4) | V <sub>I</sub> = V <sub>CCI</sub> or GND, I <sub>O</sub> = 0 |  | 1.65V to 5.5V    | 1.65V to 5.5V    |                       |     |     |                        | 4   | μA   |
| ΔI <sub>CCA</sub>                                      | A port   | One A port at V <sub>CCA</sub> - 0.6V,<br>DIR at V <sub>CCA</sub> ,<br>B port = open   | 3V to 5.5V       | 3V to 5.5V       |                       |     |     |                        | 50  | μA   |
|  | DIR  | DIR at V <sub>CCA</sub> - 0.6V,<br>B port = open,<br>A port at V <sub>CCA</sub> or GND |                  |                  |                       |     |     |                        | 50  |      |
| ΔI <sub>CCB</sub>                                      | B port   | One B port at V <sub>CCB</sub> - 0.6V,<br>DIR at GND, A port = open                    | 3V to 5.5V       | 3V to 5.5V       |                       |     |     |                        | 50  | μA   |
| C <sub>I</sub>   | DIR  | V <sub>I</sub> = V <sub>CCA</sub> or GND   | 3.3V             | 3.3V             |                       |     | 2.5 |                        |     | pF   |
| C <sub>io</sub>  | A or B port  | V <sub>O</sub> = V <sub>CCA/B</sub> or GND   | 3.3V             | 3.3V             |                       |     | 6   |                        |     | pF   |

(1) V<sub>CCO</sub> is the V<sub>CC</sub> associated with the output port.

(2) V<sub>CCI</sub> is the V<sub>CC</sub> associated with the input port.

### 5.6 Switching Characteristics: $V_{CCA} = 1.8V \pm 0.15V$

over recommended operating free-air temperature range,  $V_{CCA} = 1.8V \pm 0.15V$  (unless otherwise noted) (see [Figure 6-1](#))

| PARAMETER   | FROM (INPUT) | TO (OUTPUT) | $V_{CCB} = 1.8V \pm 0.15V$ |      | $V_{CCB} = 2.5V \pm 0.2V$ |      | $V_{CCB} = 3.3V \pm 0.3V$ |      | $V_{CCB} = 5V \pm 0.5V$ |      | UNIT |
|-------------|--------------|-------------|----------------------------|------|---------------------------|------|---------------------------|------|-------------------------|------|------|
|             |              |             | MIN                        | MAX  | MIN                       | MAX  | MIN                       | MAX  | MIN                     | MAX  |      |
| $t_{PLH}$   | A            | B           | 3                          | 17.7 | 2.2                       | 10.3 | 1.7                       | 8.3  | 1.4                     | 7.2  | ns   |
| $t_{PHL}$   |              |             | 2.8                        | 14.3 | 2.2                       | 8.5  | 1.8                       | 7.1  | 1.7                     | 7    |      |
| $t_{PLH}$   | B            | A           | 3                          | 17.7 | 2.3                       | 16   | 2.1                       | 15.5 | 1.9                     | 15.1 | ns   |
| $t_{PHL}$   |              |             | 2.8                        | 14.3 | 2.1                       | 12.9 | 2                         | 12.6 | 1.8                     | 12.2 |      |
| $t_{PHZ}$   | DIR          | A           | 5.5                        | 30.9 | 5.5                       | 30.5 | 5.5                       | 30.5 | 5.5                     | 29.3 | ns   |
| $t_{PLZ}$   |              |             | 4.3                        | 19.7 | 4.2                       | 19.6 | 4.1                       | 19.5 | 4                       | 19.4 |      |
| $t_{PHZ}$   | DIR          | B           | 6                          | 27.9 | 5                         | 14.9 | 5                         | 11.3 | 4.1                     | 8.6  | ns   |
| $t_{PLZ}$   |              |             | 5                          | 19.5 | 3.9                       | 12.6 | 4.3                       | 9.7  | 2.1                     | 7.1  |      |
| $t_{PZH}^1$ | DIR          | A           | 37.2                       |      | 28.6                      |      | 25.2                      |      | 22.2                    |      | ns   |
| $t_{PZL}^1$ |              |             | 42.2                       |      | 27.8                      |      | 23.9                      |      | 20.8                    |      |      |
| $t_{PZH}^1$ | DIR          | B           | 37.4                       |      | 29.9                      |      | 27.8                      |      | 26.6                    |      | ns   |
| $t_{PZL}^1$ |              |             | 45.2                       |      | 39                        |      | 37.6                      |      | 36.3                    |      |      |

(1) The enable time is a calculated value, derived using the formula shown in the [Enable Times](#) section.

### 5.7 Switching Characteristics: $V_{CCA} = 2.5V \pm 0.2V$

over recommended operating free-air temperature range,  $V_{CCA} = 2.5V \pm 0.2V$  (unless otherwise noted) (see [Figure 6-1](#))

| PARAMETER   | FROM (INPUT) | TO (OUTPUT) | $V_{CCB} = 1.8V \pm 0.15V$ |      | $V_{CCB} = 2.5V \pm 0.2V$ |      | $V_{CCB} = 3.3V \pm 0.3V$ |      | $V_{CCB} = 5V \pm 0.5V$ |      | UNIT |
|-------------|--------------|-------------|----------------------------|------|---------------------------|------|---------------------------|------|-------------------------|------|------|
|             |              |             | MIN                        | MAX  | MIN                       | MAX  | MIN                       | MAX  | MIN                     | MAX  |      |
| $t_{PLH}$   | A            | B           | 2.3                        | 16   | 1.5                       | 8.5  | 1.3                       | 6.4  | 1.1                     | 5.1  | ns   |
| $t_{PHL}$   |              |             | 2.1                        | 12.9 | 1.4                       | 7.5  | 1.3                       | 5.4  | 0.9                     | 4.6  |      |
| $t_{PLH}$   | B            | A           | 2.2                        | 10.3 | 1.5                       | 8.5  | 1.4                       | 8    | 1                       | 7.5  | ns   |
| $t_{PHL}$   |              |             | 2.2                        | 8.5  | 1.4                       | 7.5  | 1.3                       | 7    | 0.9                     | 6.2  |      |
| $t_{PHZ}$   | DIR          | A           | 4.2                        | 17.1 | 4.2                       | 16.8 | 4.1                       | 16.8 | 4.1                     | 16.5 | ns   |
| $t_{PLZ}$   |              |             | 3.2                        | 12.6 | 3.2                       | 12.5 | 3.2                       | 12.3 | 3                       | 12.3 |      |
| $t_{PHZ}$   | DIR          | B           | 6                          | 27.9 | 4.7                       | 13.9 | 4.7                       | 10.5 | 3.5                     | 7.6  | ns   |
| $t_{PLZ}$   |              |             | 4.2                        | 18.9 | 3.6                       | 11.2 | 3.6                       | 8.9  | 1.4                     | 6.2  |      |
| $t_{PZH}^1$ | DIR          | A           | 29.2                       |      | 19.7                      |      | 16.9                      |      | 13.7                    |      | ns   |
| $t_{PZL}^1$ |              |             | 36.4                       |      | 21.4                      |      | 17.5                      |      | 13.8                    |      |      |
| $t_{PZH}^1$ | DIR          | B           | 28.6                       |      | 21                        |      | 18.7                      |      | 17.4                    |      | ns   |
| $t_{PZL}^1$ |              |             | 30                         |      | 24.3                      |      | 22.2                      |      | 21.1                    |      |      |

(1) The enable time is a calculated value, derived using the formula shown in the [Enable Times](#) section.

### 5.8 Switching Characteristics: $V_{CCA} = 3.3V \pm 0.3V$

over recommended operating free-air temperature range,  $V_{CCA} = 3.3V \pm 0.3V$  (unless otherwise noted) (see [Figure 6-1](#))

| PARAMETER   | FROM (INPUT) | TO (OUTPUT) | $V_{CCB} = 1.8V \pm 0.15V$ |      | $V_{CCB} = 2.5V \pm 0.2V$ |      | $V_{CCB} = 3.3V \pm 0.3V$ |      | $V_{CCB} = 5V \pm 0.5V$ |      | UNIT |
|-------------|--------------|-------------|----------------------------|------|---------------------------|------|---------------------------|------|-------------------------|------|------|
|             |              |             | MIN                        | MAX  | MIN                       | MAX  | MIN                       | MAX  | MIN                     | MAX  |      |
| $t_{PLH}$   | A            | B           | 2.1                        | 15.5 | 1.4                       | 8    | 0.7                       | 5.6  | 0.7                     | 4.4  | ns   |
| $t_{PHL}$   |              |             | 2                          | 12.6 | 1.3                       | 7    | 0.8                       | 5    | 0.7                     | 4    |      |
| $t_{PLH}$   | B            | A           | 1.7                        | 8.3  | 1.3                       | 6.4  | 0.7                       | 5.8  | 0.6                     | 5.4  | ns   |
| $t_{PHL}$   |              |             | 1.8                        | 7.1  | 1.3                       | 5.4  | 0.8                       | 5    | 0.7                     | 4.5  |      |
| $t_{PHZ}$   | DIR          | A           | 4.5                        | 10.9 | 4.5                       | 10.8 | 4.4                       | 10.8 | 4.4                     | 10.4 | ns   |
| $t_{PLZ}$   |              |             | 3.4                        | 8.4  | 3.7                       | 8.4  | 3.9                       | 8.1  | 3.3                     | 7.8  |      |
| $t_{PHZ}$   | DIR          | B           | 5.7                        | 27.3 | 4.7                       | 13.7 | 4.7                       | 10.4 | 2.9                     | 7.4  | ns   |
| $t_{PLZ}$   |              |             | 4.5                        | 17.7 | 3.5                       | 11.3 | 4.3                       | 8.3  | 1                       | 5.6  |      |
| $t_{PZH}^1$ | DIR          | A           | 26                         |      | 17.7                      |      | 14.1                      |      | 11                      |      | ns   |
| $t_{PZL}^1$ |              |             | 34.4                       |      | 19.1                      |      | 15.4                      |      | 11.9                    |      |      |
| $t_{PZH}^1$ | DIR          | B           | 23.9                       |      | 16.4                      |      | 13.9                      |      | 12.2                    |      | ns   |
| $t_{PZL}^1$ |              |             | 23.5                       |      | 17.8                      |      | 15.8                      |      | 14.4                    |      |      |

(1) The enable time is a calculated value, derived using the formula shown in the [Enable Times](#) section.

### 5.9 Switching Characteristics: $V_{CCA} = 5V \pm 0.5V$

over recommended operating free-air temperature range,  $V_{CCA} = 5V \pm 0.5V$  (unless otherwise noted) (see [Figure 6-1](#))

| PARAMETER   | FROM (INPUT) | TO (OUTPUT) | $V_{CCB} = 1.8V \pm 0.15V$ |      | $V_{CCB} = 2.5V \pm 0.2V$ |      | $V_{CCB} = 3.3V \pm 0.3V$ |      | $V_{CCB} = 5V \pm 0.5V$ |     | UNIT |
|-------------|--------------|-------------|----------------------------|------|---------------------------|------|---------------------------|------|-------------------------|-----|------|
|             |              |             | MIN                        | MAX  | MIN                       | MAX  | MIN                       | MAX  | MIN                     | MAX |      |
| $t_{PLH}$   | A            | B           | 1.9                        | 15.1 | 1                         | 7.5  | 0.6                       | 5.4  | 0.5                     | 3.9 | ns   |
| $t_{PHL}$   |              |             | 1.8                        | 12.2 | 0.9                       | 6.2  | 0.7                       | 4.5  | 0.5                     | 3.5 |      |
| $t_{PLH}$   | B            | A           | 1.4                        | 7.2  | 1                         | 5.1  | 0.7                       | 4.4  | 0.5                     | 3.9 | ns   |
| $t_{PHL}$   |              |             | 1.7                        | 7    | 0.9                       | 4.6  | 0.7                       | 4    | 0.5                     | 3.5 |      |
| $t_{PHZ}$   | DIR          | A           | 2.9                        | 8.2  | 2.9                       | 7.9  | 2.8                       | 7.9  | 2.2                     | 7.8 | ns   |
| $t_{PLZ}$   |              |             | 1.4                        | 6.9  | 1.3                       | 6.7  | 0.7                       | 6.7  | 0.7                     | 6.6 |      |
| $t_{PHZ}$   | DIR          | B           | 5.8                        | 26.1 | 4.4                       | 13.9 | 4.4                       | 10.1 | 1.3                     | 7.3 | ns   |
| $t_{PLZ}$   |              |             | 4.7                        | 16.9 | 3.3                       | 11   | 4                         | 7.7  | 1                       | 5.6 |      |
| $t_{PZH}^1$ | DIR          | A           | 24.1                       |      | 16.1                      |      | 12.1                      |      | 9.5                     |     | ns   |
| $t_{PZL}^1$ |              |             | 33.1                       |      | 18.5                      |      | 14.1                      |      | 10.8                    |     |      |
| $t_{PZH}^1$ | DIR          | B           | 22                         |      | 14.2                      |      | 12.1                      |      | 10.5                    |     | ns   |
| $t_{PZL}^1$ |              |             | 20.4                       |      | 14.1                      |      | 12.4                      |      | 11.3                    |     |      |

(1) The enable time is a calculated value, derived using the formula shown in the [Enable Times](#) section.

## 5.10 Operating Characteristics

$T_A = 25^\circ\text{C}$

| PARAMETER                |                                | TEST CONDITIONS  | $V_{CCA} =$<br>$V_{CCB} = 1.8\text{V}$ | $V_{CCA} =$<br>$V_{CCB} = 2.5\text{V}$ | $V_{CCA} =$<br>$V_{CCB} = 3.3\text{V}$ | $V_{CCA} =$<br>$V_{CCB} = 5\text{V}$ | UNIT |
|--------------------------|--------------------------------|--|--|--|--|--------------------------------------|------|
|                          |                                |  | TYP                                    | TYP                                    | TYP                                    | TYP                                  |      |
| $C_{pdA}$ <sup>(1)</sup> | A-port input,<br>B-port output | $C_L = 0\text{pF}$ ,<br>$f = 10\text{MHz}$ ,<br>$t_r = t_f = 1\text{ns}$ | 3                                      | 4                                      | 4                                      | 4                                    | pF   |
|                          | B-port input,<br>A-port output |  | 18                                     | 19                                     | 20                                     | 21                                   |      |
| $C_{pdB}$ <sup>(1)</sup> | A-port input,<br>B-port output | $C_L = 0\text{pF}$ ,<br>$f = 10\text{MHz}$ ,<br>$t_r = t_f = 1\text{ns}$ | 18                                     | 19                                     | 20                                     | 21                                   | pF   |
|                          | B-port input,<br>A-port output |  | 3                                      | 4                                      | 4                                      | 4                                    |      |

(1) Power dissipation capacitance per transceiver.

### 5.11 Typical Characteristics

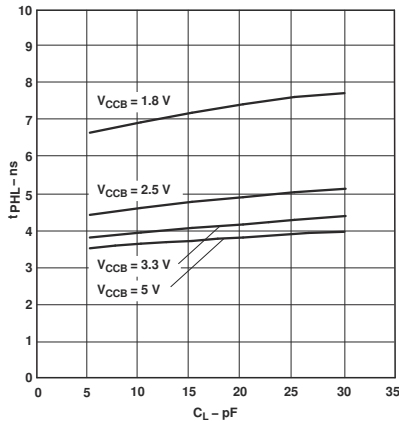

Figure 5-1. Typical Propagation Delay of High-to-Low (A to B) vs Load Capacitance  $T_A = 25^\circ\text{C}$ ,  $V_{CCA} = 1.8\text{V}$

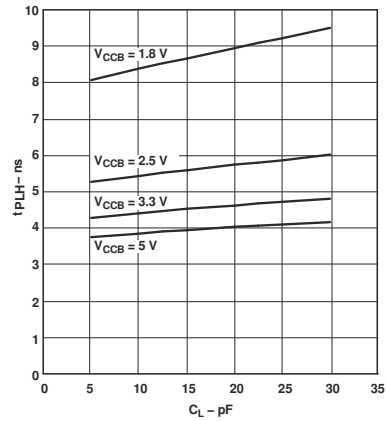

Figure 5-2. Typical Propagation Delay of Low-to-High (A to B) vs Load Capacitance  $T_A = 25^\circ\text{C}$ ,  $V_{CCA} = 1.8\text{V}$

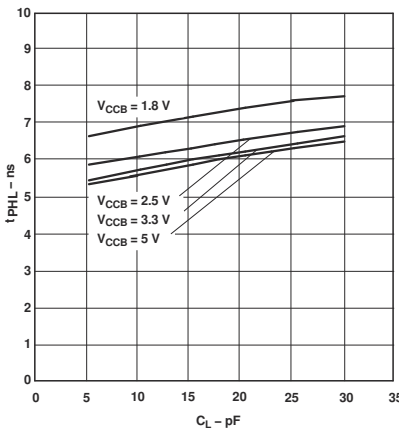

Figure 5-3. Typical Propagation Delay of High-to-Low (B to A) vs Load Capacitance  $T_A = 25^\circ\text{C}$ ,  $V_{CCA} = 1.8\text{V}$

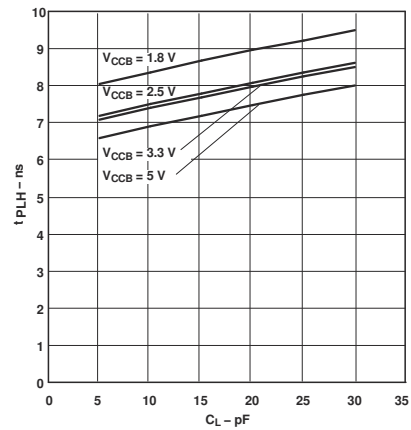

Figure 5-4. Typical Propagation Delay of Low-to-High (B to A) vs Load Capacitance  $T_A = 25^\circ\text{C}$ ,  $V_{CCA} = 1.8\text{V}$

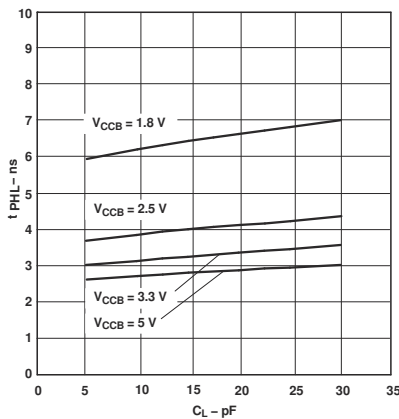

Figure 5-5. Typical Propagation Delay of High-to-Low (A to B) vs Load Capacitance  $T_A = 25^\circ\text{C}$ ,  $V_{CCA} = 2.5\text{V}$

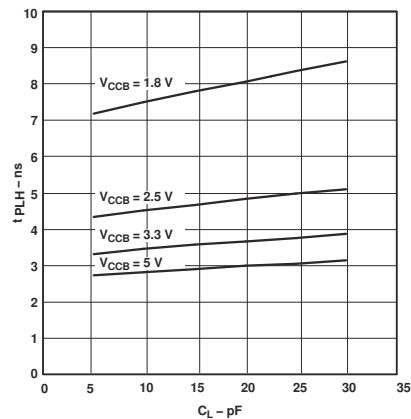

Figure 5-6. Typical Propagation Delay of Low-to-High (A to B) vs Load Capacitance  $T_A = 25^\circ\text{C}$ ,  $V_{CCA} = 2.5\text{V}$

### 5.11 Typical Characteristics (continued)

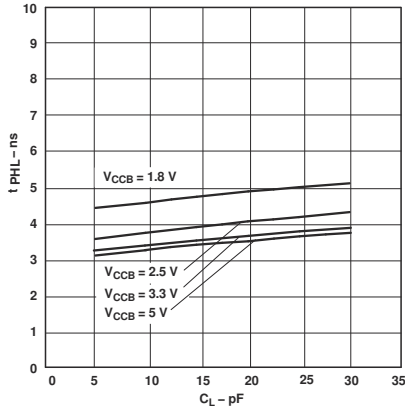

Figure 5-7. Typical Propagation Delay of High-to-Low (B to A) vs Load Capacitance  $T_A = 25^\circ\text{C}$ ,  $V_{CCA} = 2.5\text{V}$

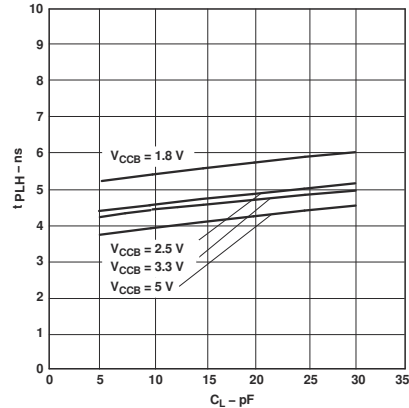

Figure 5-8. Typical Propagation Delay of Low-to-High (B to A) vs Load Capacitance  $T_A = 25^\circ\text{C}$ ,  $V_{CCA} = 2.5\text{V}$

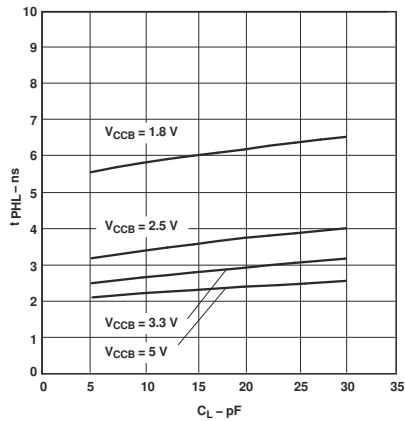

Figure 5-9. Typical Propagation Delay of High-to-Low (A to B) vs Load Capacitance  $T_A = 25^\circ\text{C}$ ,  $V_{CCA} = 3.3\text{V}$

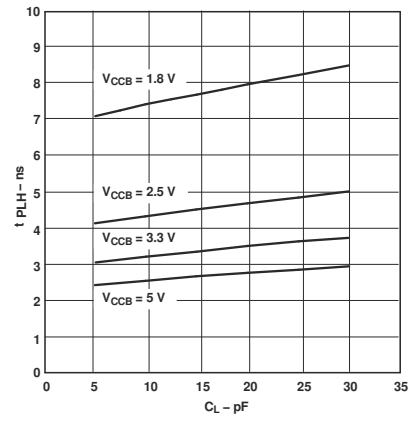

Figure 5-10. Typical Propagation Delay of Low-to-High (A to B) vs Load Capacitance  $T_A = 25^\circ\text{C}$ ,  $V_{CCA} = 3.3\text{V}$

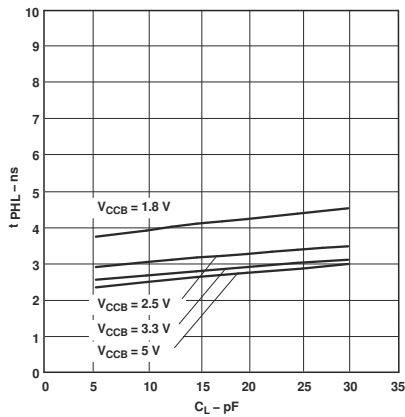

Figure 5-11. Typical Propagation Delay of High-to-Low (B to A) vs Load Capacitance  $T_A = 25^\circ\text{C}$ ,  $V_{CCA} = 3.3\text{V}$

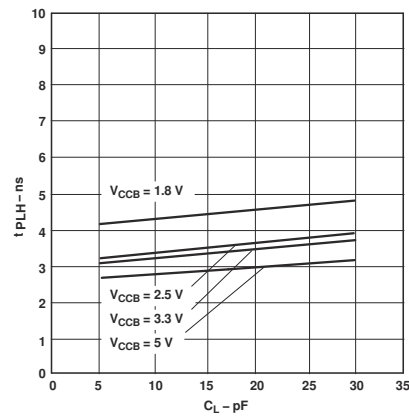

Figure 5-12. Typical Propagation Delay of Low-to-High (B to A) vs Load Capacitance  $T_A = 25^\circ\text{C}$ ,  $V_{CCA} = 3.3\text{V}$

5.11 Typical Characteristics (continued)

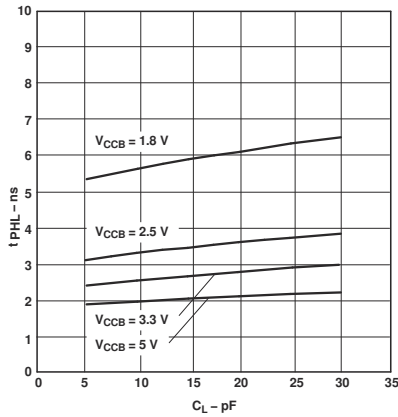

Figure 5-13. Typical Propagation Delay of High-to-Low (A to B) vs Load Capacitance  $T_A = 25^\circ\text{C}$ ,  $V_{CCA} = 5\text{V}$

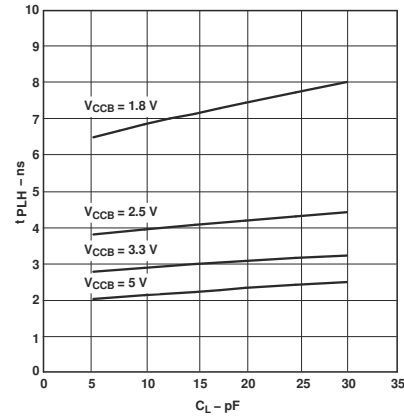

Figure 5-14. Typical Propagation Delay of Low-to-High (A to B) vs Load Capacitance  $T_A = 25^\circ\text{C}$ ,  $V_{CCA} = 5\text{V}$

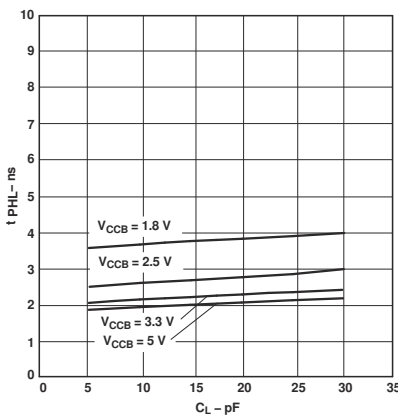

Figure 5-15. Typical Propagation Delay of High-to-Low (B to A) vs Load Capacitance  $T_A = 25^\circ\text{C}$ ,  $V_{CCA} = 5\text{V}$

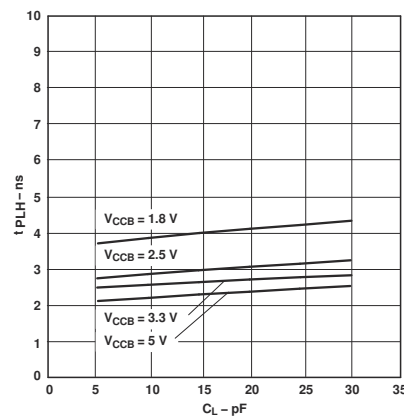
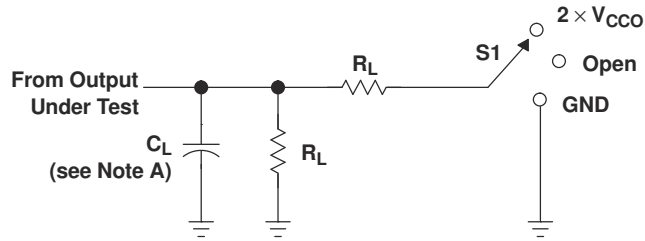

Figure 5-16. Typical Propagation Delay of Low-to-High (B to A) vs Load Capacitance  $T_A = 25^\circ\text{C}$ ,  $V_{CCA} = 5\text{V}$

## 6 Parameter Measurement Information



LOAD CIRCUIT

| $V_{CCO}$                        | $C_L$ | $R_L$        | $V_{TP}$ |
|----------------------------------|-------|--------------|----------|
| $1.8\text{ V} \pm 0.15\text{ V}$ | 15 pF | 2 k $\Omega$ | 0.15 V   |
| $2.5\text{ V} \pm 0.2\text{ V}$  | 15 pF | 2 k $\Omega$ | 0.15 V   |
| $3.3\text{ V} \pm 0.3\text{ V}$  | 15 pF | 2 k $\Omega$ | 0.3 V    |
| $5\text{ V} \pm 0.5\text{ V}$    | 15 pF | 2 k $\Omega$ | 0.3 V    |

| TEST              | S1                 |
|-------------------|--------------------|
| $t_{pd}$          | Open               |
| $t_{PLZ}/t_{PZL}$ | $2 \times V_{CCO}$ |
| $t_{PHZ}/t_{PZH}$ | GND                |

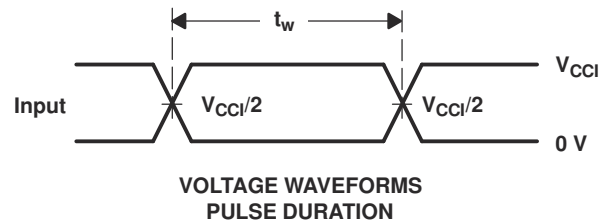

VOLTAGE WAVEFORMS  
PULSE DURATION

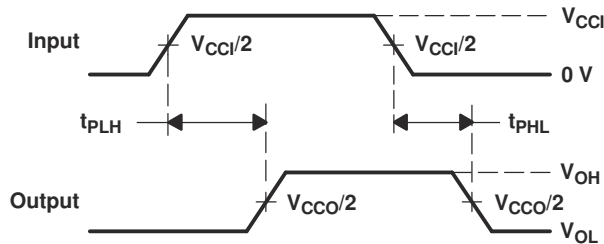

VOLTAGE WAVEFORMS  
PROPAGATION DELAY TIMES

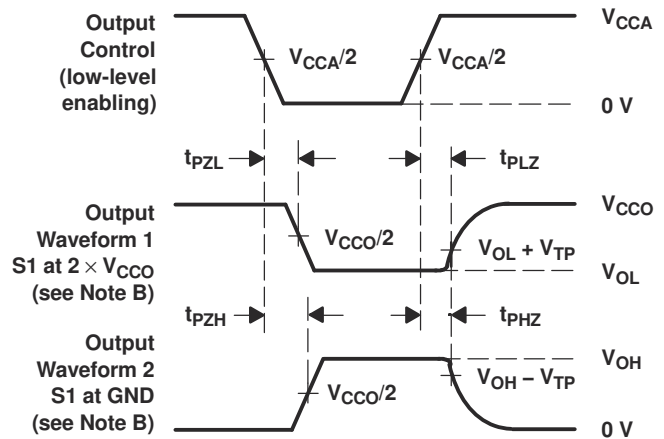

VOLTAGE WAVEFORMS  
ENABLE AND DISABLE TIMES

- NOTES:
- $C_L$  includes probe and jig capacitance.
  - Waveform 1 is for an output with internal conditions such that the output is low, except when disabled by the output control. Waveform 2 is for an output with internal conditions such that the output is high, except when disabled by the output control.
  - All input pulses are supplied by generators having the following characteristics:  $PRR \leq 10\text{ MHz}$ ,  $Z_O = 50\ \Omega$ ,  $dv/dt \geq 1\text{ V/ns}$ .
  - The outputs are measured one at a time, with one transition per measurement.
  - $t_{PLZ}$  and  $t_{PHZ}$  are the same as  $t_{dis}$ .
  - $t_{PZL}$  and  $t_{PZH}$  are the same as  $t_{en}$ .
  - $t_{PLH}$  and  $t_{PHL}$  are the same as  $t_{pd}$ .
  - $V_{CC1}$  is the  $V_{CC}$  associated with the input port.
  - $V_{CCO}$  is the  $V_{CC}$  associated with the output port.
  - All parameters and waveforms are not applicable to all devices.

Figure 6-1. Load Circuit and Voltage Waveforms

## 7 Detailed Description

### 7.1 Overview

The SN74LVC2T45 is a dual-bit, dual-supply noninverting voltage level translation device.  $V_{CCA}$  supports pin Ax and the direction control pin, and  $V_{CCB}$  supports pin Bx. The A port can accept I/O voltages ranging from 1.65V to 5.5V, while the B port can accept I/O voltages from 1.65V to 5.5V. The high on DIR allows data transmission from A to B and a low on DIR allows data transmission from B to A.

### 7.2 Functional Block Diagram

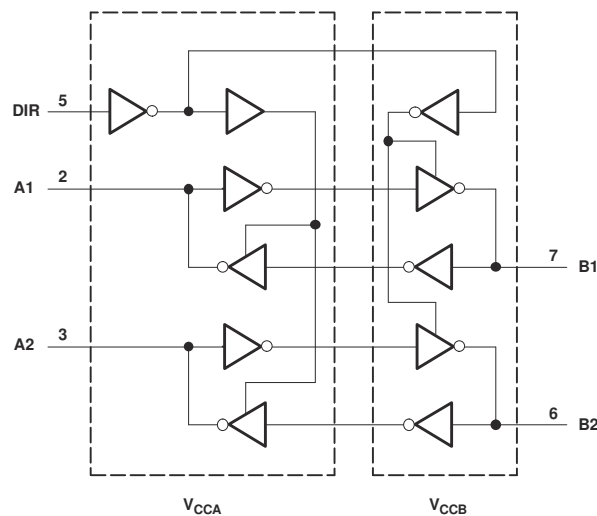

Figure 7-1. Logic Diagram (Positive Logic)

### 7.3 Feature Description

#### 7.3.1 Fully Configurable Dual-Rail Design Allows Each Port to Operate Over the Full 1.65V to 5.5V Power-Supply Range

Both  $V_{CCA}$  and  $V_{CCB}$  can be supplied at any voltage between 1.65V and 5.5V making the device suitable for translating between any of the voltage nodes (1.8V, 2.5V, 3.3V, and 5V).

#### 7.3.2 Support High-Speed Translation

SN74LVC2T45 can support high data rate applications. The translated signal data rate can be up to 420Mbps when signal is translated from 3.3V to 5V.

#### 7.3.3 $I_{off}$ Supports Partial-Power-Down Mode Operation

$I_{off}$  will prevent backflow current by disabling I/O output circuits when the device is in Partial-Power-Down mode. The inputs and outputs for this device enter a high-impedance state when the device is powered down, inhibiting current backflow into the device. The maximum leakage into or out of any input or output pin on the device is specified by  $I_{off}$  in the *Electrical Characteristics*.

#### 7.3.4 Balanced High-Drive CMOS Push-Pull Outputs

A balanced output allows the device to sink and source similar currents. The high drive capability of this device creates fast edges into light loads so impedance matching and load conditions should be considered to prevent ringing. Additionally, the outputs of this device are capable of driving larger currents than the device can sustain without being damaged. Two outputs can be connected together for a stronger output drive strength. The electrical and thermal limits defined in the [Absolute Maximum Ratings](#) must be followed at all times.

#### 7.3.5 Glitch-Free Power Supply Sequencing

Either supply rail may be powered on or off in any order without producing a glitch on the I/Os (that is, where the output erroneously transitions to VCC when it should be held low or vice versa). Glitches of this nature can

be misinterpreted by a peripheral as a valid data bit, which could trigger a false device reset of the peripheral, a false device configuration of the peripheral, or even a false data initialization by the peripheral.

### 7.3.6 $V_{cc}$ Isolation

The I/Os of both ports will enter a high-impedance state when either of the supplies are at GND, while the other supply is still connected to the device. The maximum leakage into or out of any input or output pin on the device is specified by  $I_{off}$  in the *Electrical Characteristics*.

## 7.4 Device Functional Modes

Table 7-1 lists the functional modes of the SN74LVC2T45 device.

**Table 7-1. Function Table (Each Transceiver)<sup>(1)</sup>**

| INPUT DIR | OPERATION       |
|-----------|-----------------|
| L         | B data to A bus |
| H         | A data to B bus |

(1) Input circuits of the data I/Os always are active.

## 8 Application and Implementation

### Note

Information in the following applications sections is not part of the TI component specification, and TI does not warrant its accuracy or completeness. TI's customers are responsible for determining suitability of components for their purposes, as well as validating and testing their design implementation to confirm system functionality.

### 8.1 Application Information

The SN74LVC2T45 device can be used in level-translation applications for interfacing devices or systems operating at different interface voltages with one another. The maximum data rate can be up to 420Mbps when the device translates signal from 3.3V to 5V. It is recommended to tie all unused I/Os to GND. The device should not have any floating I/Os when changing translation direction.

### 8.2 Typical Applications

#### 8.2.1 Unidirectional Logic Level-Shifting Application

Figure 8-1 shows an example of the SN74LVC2T45 being used in a unidirectional logic level-shifting application.

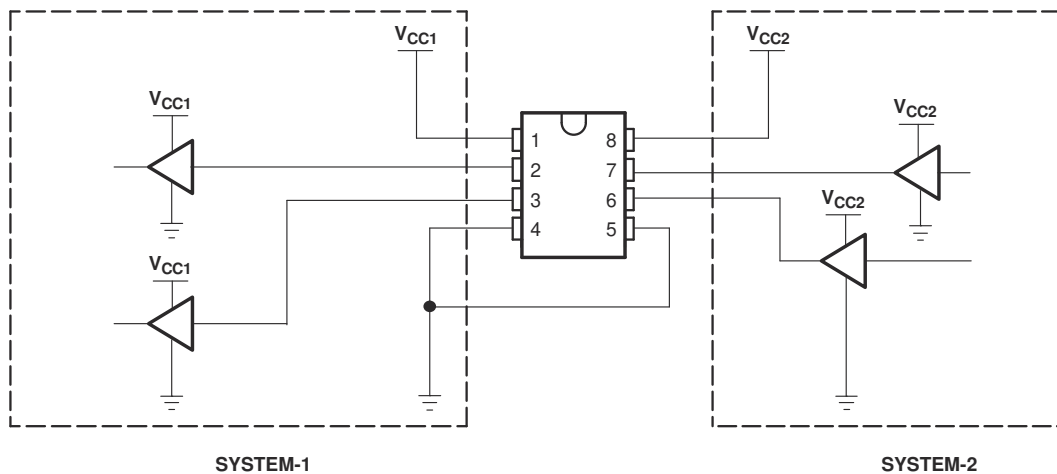

Figure 8-1. Unidirectional Logic Level-Shifting Application

#### 8.2.1.1 Design Requirements

Table 8-1 lists the pins and pin descriptions of the SN74LVC2T45 connections with SYSTEM-1 and SYSTEM-2.

Table 8-1. SN74LVC2T45 Pin Connections With SYSTEM-1 and SYSTEM-2

| PIN | NAME             | FUNCTION         | DESCRIPTION  |
|-----|------------------|------------------|--|
| 1   | V <sub>CCA</sub> | V <sub>CC1</sub> | SYSTEM-1 supply voltage (1.65V to 5.5V)                    |
| 2   | A1               | OUT1             | Output level depends on V <sub>CC1</sub> voltage.          |
| 3   | A2               | OUT2             | Output level depends on V <sub>CC1</sub> voltage.          |
| 4   | GND              | GND              | Device GND   |
| 5   | DIR              | DIR              | GND (low level) determines B-port to A-port direction.     |
| 6   | B2               | IN2              | Input threshold value depends on V <sub>CC2</sub> voltage. |
| 7   | B1               | IN1              | Input threshold value depends on V <sub>CC2</sub> voltage. |
| 8   | V <sub>CCB</sub> | V <sub>CC2</sub> | SYSTEM-2 supply voltage (1.65V to 5.5V)                    |

For this design example, use the parameters listed in Table 8-2.

**Table 8-2. Design Parameters**

| DESIGN PARAMETER     | EXAMPLE VALUE |
|----------------------|---------------|
| Input voltage range  | 1.65V to 5.5V |
| Output voltage range | 1.65V to 5.5V |

**8.2.1.2 Detailed Design Procedure**

To begin the design process, determine the following:

- Input voltage range
  - Use the supply voltage of the device that is driving the SN74LVC2T45 device to determine the input voltage range. For a valid logic high, the value must exceed the  $V_{IH}$  of the input port. For a valid logic low, the value must be less than the  $V_{IL}$  of the input port.
- Output voltage range
  - Use the supply voltage of the device that the SN74LVC2T45 device is driving to determine the output voltage range.

**8.2.1.3 Application Curve**

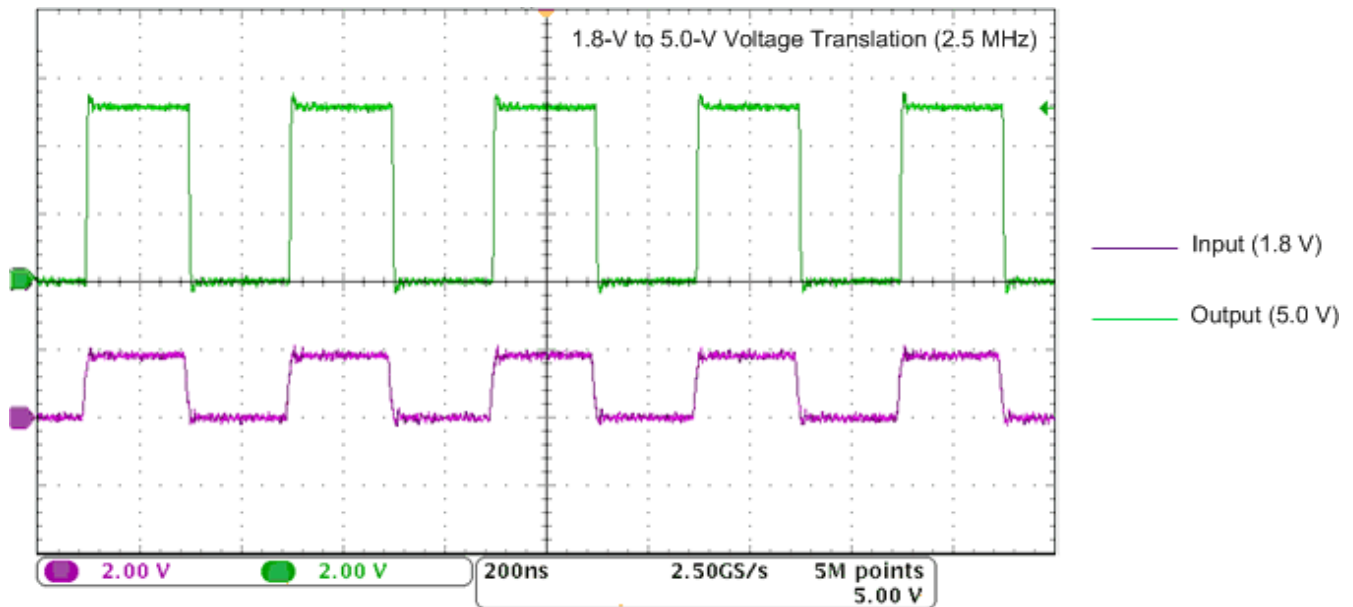

## 8.2.2 Bidirectional Logic Level-Shifting Application

Figure 8-2 shows the SN74LVC2T45 being used in a bidirectional logic level-shifting application. Because the SN74LVC2T45 does not have an output-enable (OE) pin, the system designer should take precautions to avoid bus contention between SYSTEM-1 and SYSTEM-2 when changing directions.

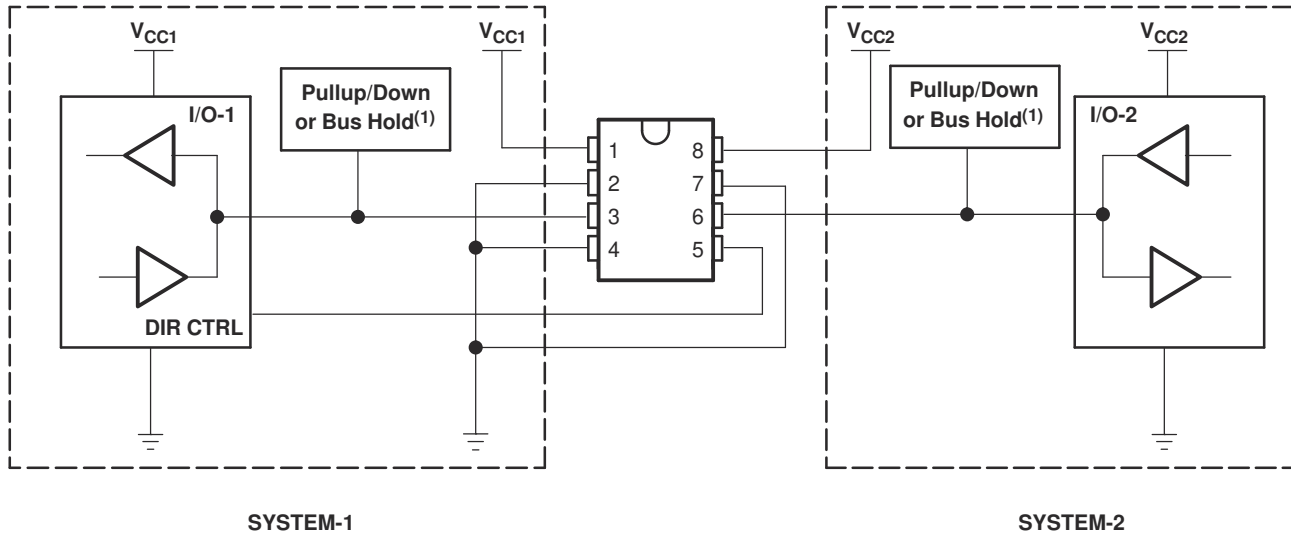

Figure 8-2. Bidirectional Logic Level-Shifting Application

### 8.2.2.1 Design Requirements

Refer to [Section 8.2.1](#).

### 8.2.2.2 Detailed Design Procedure

Table 8-3 provides data transmission from SYSTEM-1 to SYSTEM-2 and then from SYSTEM-2 to SYSTEM-1.

Table 8-3. Data Transmission Sequence

| STATE | DIR CTRL | I/O-1 | I/O-2 | DESCRIPTION  |
|-------|----------|-------|-------|--|
| 1     | H        | Out   | In    | SYSTEM-1 data to SYSTEM-2  |
| 2     | H        | Hi-Z  | Hi-Z  | SYSTEM-2 is getting ready to send data to SYSTEM-1. I/O-1 and I/O-2 are disabled. The bus-line state depends on pullup or pulldown. <sup>(1)</sup> |
| 3     | L        | Hi-Z  | Hi-Z  | DIR bit is flipped. I/O-1 and I/O-2 still are disabled. The bus-line state depends on pullup or pulldown. <sup>(1)</sup>                           |
| 4     | L        | In    | Out   | SYSTEM-2 data to SYSTEM-1  |

(1) SYSTEM-1 and SYSTEM-2 must use the same conditions, that is, both pullup or both pulldown.

#### 8.2.2.2.1 Enable Times

Calculate the enable times for the SN74LVC2T45 using the following formulas:

- $t_{PZH}(\text{DIR to A}) = t_{PLZ}(\text{DIR to B}) + t_{PLH}(\text{B to A})$
- $t_{PZL}(\text{DIR to A}) = t_{PHZ}(\text{DIR to B}) + t_{PHL}(\text{B to A})$
- $t_{PZH}(\text{DIR to B}) = t_{PLZ}(\text{DIR to A}) + t_{PLH}(\text{A to B})$
- $t_{PZL}(\text{DIR to B}) = t_{PHZ}(\text{DIR to A}) + t_{PHL}(\text{A to B})$

In a bidirectional application, these enable times provide the maximum delay from the time the DIR bit is switched until an output is expected. For example, if the SN74LVC2T45 initially is transmitting from A to B, then the DIR bit is switched; the B port of the device must be disabled before presenting it with an input. After the B port has been disabled, an input signal applied to it appears on the corresponding A port after the specified propagation delay.

### 8.2.2.3 Application Curve

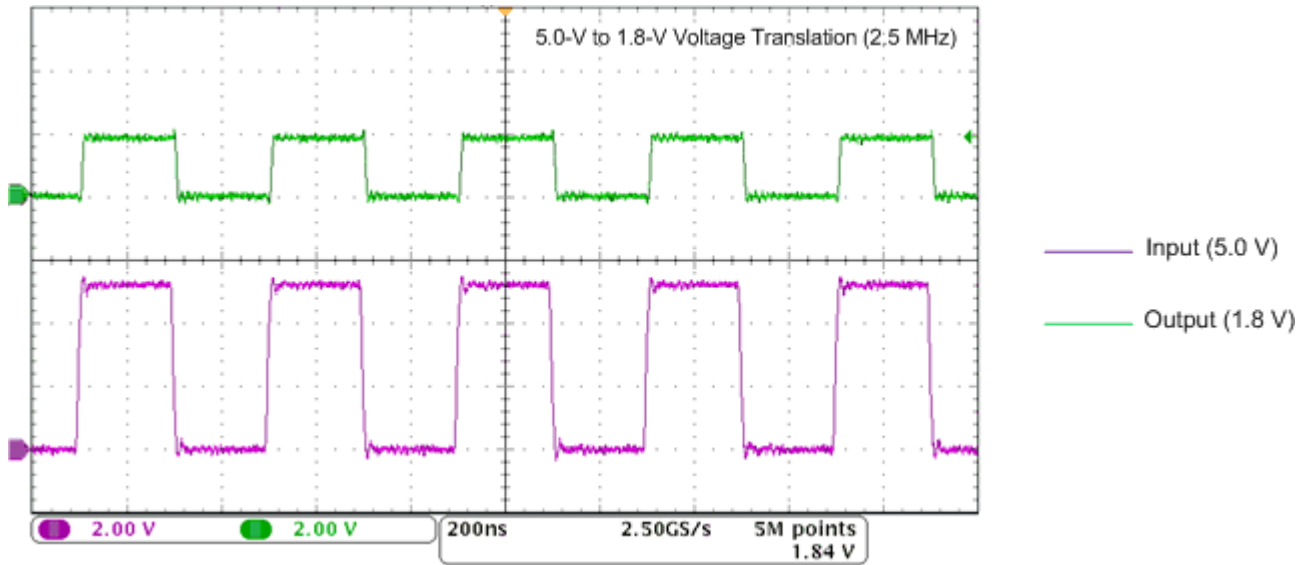

### 8.3 Power Supply Recommendations

Always apply a ground reference to the GND pins first. This device is designed for glitch free power sequencing without any supply sequencing requirements such as ramp order or ramp rate.

This device was designed with various power supply sequencing methods in mind to help prevent unintended triggering of downstream devices, as described in [Glitch-free Power Supply Sequencing](#).

#### 8.3.1 Power-Up Consideration

Each  $V_{CC}$  pin must have a good bypass capacitor to prevent power disturbance. For devices with a single supply,  $0.1\mu\text{F}$  is recommended. If there are multiple  $V_{CC}$  pins,  $0.01\mu\text{F}$  or  $0.022\mu\text{F}$  is recommended for each power pin. It is acceptable to parallel multiple bypass capacitors to reject different frequencies of noise.  $0.1\mu\text{F}$  and  $1\mu\text{F}$  capacitors are commonly used in parallel. The bypass capacitor must be installed as close to the power pin as possible for best results.

**Table 8-4. Typical Total Static Power Consumption ( $I_{CCA} + I_{CCB}$ )**

| $V_{CCB}$ | $V_{CCA}$ |      |      |      |     | UNIT          |
|-----------|-----------|------|------|------|-----|---------------|
|           | 0V        | 1.8V | 2.5V | 3.3V | 5V  |               |
| 0V        | 0         | < 1  | < 1  | < 1  | < 1 | $\mu\text{A}$ |
| 1.8V      | < 1       | < 2  | < 2  | < 2  | 2   |               |
| 2.5V      | < 1       | < 2  | < 2  | < 2  | < 2 |               |
| 3.3V      | < 1       | < 2  | < 2  | < 2  | < 2 |               |
| 5V        | < 1       | 2    | < 2  | < 2  | < 2 |               |

### 8.4 Layout

#### 8.4.1 Layout Guidelines

It is recommended to follow common printed-circuit board layout guidelines for device reliability, such as the follows:

- Use bypass capacitors on the power supplies.
- Use short trace lengths to avoid excessive loading.
- Place pads on the signal paths for loading capacitors or pullup resistors to help adjust rise and fall times of signals depending on the system requirements.

### 8.4.2 Layout Example

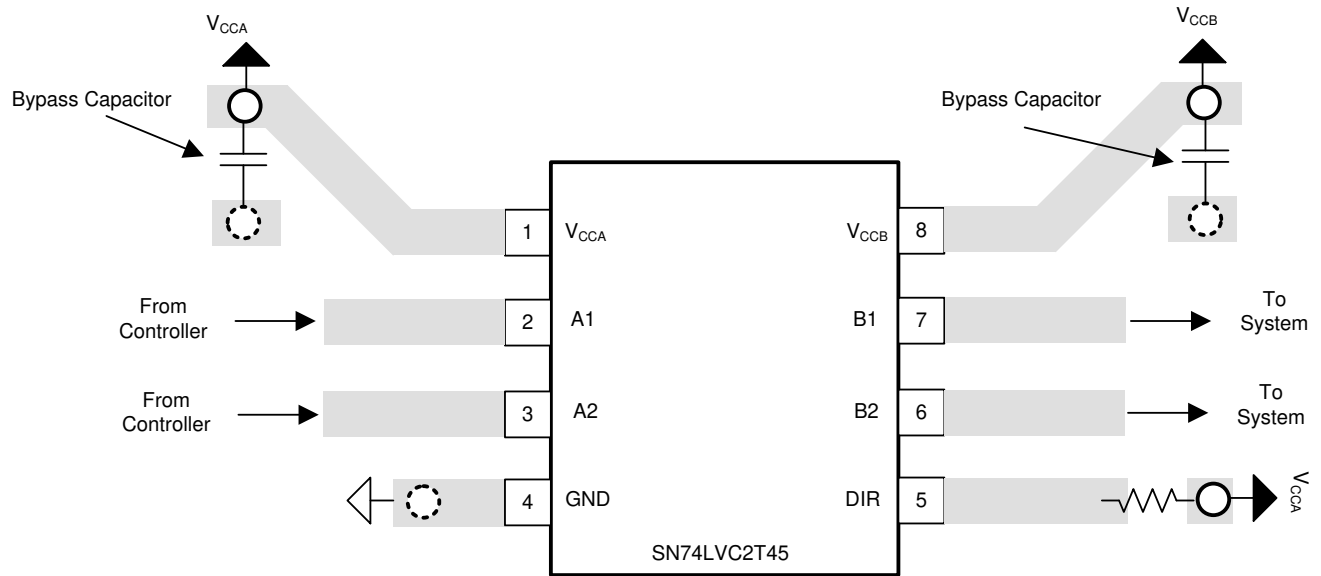
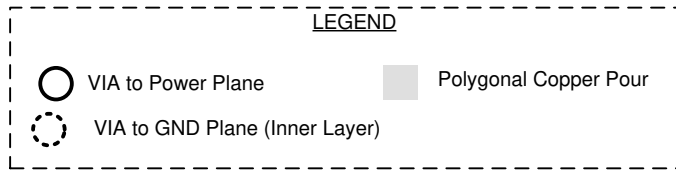

**Figure 8-3. SN74LVC2T45 Layout Example**

## 9 Device and Documentation Support

### 9.1 Documentation Support

#### 9.1.1 Related Documentation

For related documentation, see the following:

- Texas Instruments, [Implications of Slow or Floating CMOS Inputs application note](#)
- Texas Instruments, [Designing with SN74LVCXT245 and SN74LVCHXT245 Family of Direction controlled voltage translators application note](#)

### 9.2 Receiving Notification of Documentation Updates

To receive notification of documentation updates, navigate to the device product folder on [ti.com](#). Click on *Notifications* to register and receive a weekly digest of any product information that has changed. For change details, review the revision history included in any revised document.

### 9.3 Support Resources

[TI E2E™ support forums](#) are an engineer's go-to source for fast, verified answers and design help — straight from the experts. Search existing answers or ask your own question to get the quick design help you need.

Linked content is provided "AS IS" by the respective contributors. They do not constitute TI specifications and do not necessarily reflect TI's views; see TI's [Terms of Use](#).

### 9.4 Trademarks

NanoFree™ is a trademark of Texas Instruments.

TI E2E™ is a trademark of Texas Instruments.

All trademarks are the property of their respective owners.

### 9.5 Electrostatic Discharge Caution



This integrated circuit can be damaged by ESD. Texas Instruments recommends that all integrated circuits be handled with appropriate precautions. Failure to observe proper handling and installation procedures can cause damage.

ESD damage can range from subtle performance degradation to complete device failure. Precision integrated circuits may be more susceptible to damage because very small parametric changes could cause the device not to meet its published specifications.

### 9.6 Glossary

[TI Glossary](#) This glossary lists and explains terms, acronyms, and definitions.

## 10 Revision History

NOTE: Page numbers for previous revisions may differ from page numbers in the current version.

| <b>Changes from Revision M (October 2022) to Revision N (June 2024)</b> | <b>Page</b> |
|---|-------------|
| • Updated the <i>Power Supply Recommendations</i> section.....          | 19          |

| <b>Changes from Revision L (October 2022) to Revision M (October 2022)</b>   | <b>Page</b> |
|--|-------------|
| • Changed the $T_A$ <i>operating free-air temperature</i> back to 85°C ..... | 4           |

## 11 Mechanical, Packaging, and Orderable Information

The following pages include mechanical, packaging, and orderable information. This information is the most current data available for the designated devices. This data is subject to change without notice and revision of this document. For browser-based versions of this data sheet, refer to the left-hand navigation.

**PACKAGING INFORMATION**

| Orderable part number             | Status<br>(1) | Material type<br>(2) | Package   Pins  | Package qty   Carrier | RoHS<br>(3) | Lead finish/<br>Ball material<br>(4) | MSL rating/<br>Peak reflow<br>(5) | Op temp (°C) | Part marking<br>(6)             |
|-----------------------------------|---------------|----------------------|-----------------|-----------------------|-------------|--------------------------------------|-----------------------------------|--------------|---------------------------------|
| <a href="#">SN74LVC2T45DCTR</a>   | Active        | Production           | SSOP (DCT)   8  | 3000   LARGE T&R      | Yes         | SN                                   | Level-1-260C-UNLIM                | -40 to 85    | CT2<br>(R, Z)                   |
| SN74LVC2T45DCTR.A                 | Active        | Production           | SSOP (DCT)   8  | 3000   LARGE T&R      | Yes         | SN                                   | Level-1-260C-UNLIM                | -40 to 85    | CT2<br>(R, Z)                   |
| SN74LVC2T45DCTRE4                 | Active        | Production           | SSOP (DCT)   8  | 3000   LARGE T&R      | Yes         | SN                                   | Level-1-260C-UNLIM                | -40 to 85    | CT2<br>(R, Z)                   |
| <a href="#">SN74LVC2T45DCTT</a>   | Active        | Production           | SSOP (DCT)   8  | 250   SMALL T&R       | Yes         | SN                                   | Level-1-260C-UNLIM                | -40 to 85    | CT2<br>(R, Z)                   |
| SN74LVC2T45DCTT.A                 | Active        | Production           | SSOP (DCT)   8  | 250   SMALL T&R       | Yes         | SN                                   | Level-1-260C-UNLIM                | -40 to 85    | CT2<br>(R, Z)                   |
| SN74LVC2T45DCTTG4                 | Active        | Production           | SSOP (DCT)   8  | 250   SMALL T&R       | Yes         | SN                                   | Level-1-260C-UNLIM                | -40 to 85    | CT2<br>(R, Z)                   |
| <a href="#">SN74LVC2T45DCUR</a>   | Active        | Production           | VSSOP (DCU)   8 | 3000   LARGE T&R      | Yes         | SN                                   | Level-1-260C-UNLIM                | -40 to 85    | (CT2J, CT2Q, CT2R,<br>T2)<br>CZ |
| SN74LVC2T45DCUR.A                 | Active        | Production           | VSSOP (DCU)   8 | 3000   LARGE T&R      | Yes         | SN                                   | Level-1-260C-UNLIM                | -40 to 85    | (CT2J, CT2Q, CT2R,<br>T2)<br>CZ |
| SN74LVC2T45DCURE4                 | Active        | Production           | VSSOP (DCU)   8 | 3000   LARGE T&R      | Yes         | NIPDAU                               | Level-1-260C-UNLIM                | -40 to 85    | CT2R                            |
| <a href="#">SN74LVC2T45DCURG4</a> | Active        | Production           | VSSOP (DCU)   8 | 3000   LARGE T&R      | Yes         | NIPDAU                               | Level-1-260C-UNLIM                | -40 to 85    | CT2R                            |
| SN74LVC2T45DCURG4.A               | Active        | Production           | VSSOP (DCU)   8 | 3000   LARGE T&R      | Yes         | NIPDAU                               | Level-1-260C-UNLIM                | -40 to 85    | CT2R                            |
| <a href="#">SN74LVC2T45DCUT</a>   | Active        | Production           | VSSOP (DCU)   8 | 250   SMALL T&R       | Yes         | NIPDAU   SN                          | Level-1-260C-UNLIM                | -40 to 85    | (CT2J, CT2Q, CT2R,<br>T2)<br>CZ |
| SN74LVC2T45DCUT.A                 | Active        | Production           | VSSOP (DCU)   8 | 250   SMALL T&R       | Yes         | NIPDAU                               | Level-1-260C-UNLIM                | -40 to 85    | (CT2J, CT2Q, CT2R,<br>T2)<br>CZ |
| <a href="#">SN74LVC2T45DCUTG4</a> | Active        | Production           | VSSOP (DCU)   8 | 250   SMALL T&R       | Yes         | NIPDAU                               | Level-1-260C-UNLIM                | -40 to 85    | CT2R                            |
| SN74LVC2T45DCUTG4.A               | Active        | Production           | VSSOP (DCU)   8 | 250   SMALL T&R       | Yes         | NIPDAU                               | Level-1-260C-UNLIM                | -40 to 85    | CT2R                            |
| SN74LVC2T45DCUTG4.B               | Active        | Production           | VSSOP (DCU)   8 | 250   SMALL T&R       | Yes         | NIPDAU                               | Level-1-260C-UNLIM                | -40 to 85    | CT2R                            |
| <a href="#">SN74LVC2T45YZPR</a>   | Active        | Production           | DSBGA (YZP)   8 | 3000   LARGE T&R      | Yes         | SNAGCU                               | Level-1-260C-UNLIM                | -40 to 85    | (TB, TB7)                       |
| SN74LVC2T45YZPR.B                 | Active        | Production           | DSBGA (YZP)   8 | 3000   LARGE T&R      | Yes         | SNAGCU                               | Level-1-260C-UNLIM                | -40 to 85    | (TB, TB7)                       |

(1) **Status:** For more details on status, see our [product life cycle](#).

(2) **Material type:** When designated, preproduction parts are prototypes/experimental devices, and are not yet approved or released for full production. Testing and final process, including without limitation quality assurance, reliability performance testing, and/or process qualification, may not yet be complete, and this item is subject to further changes or possible discontinuation. If available for ordering, purchases will be subject to an additional waiver at checkout, and are intended for early internal evaluation purposes only. These items are sold without warranties of any kind.

(3) **RoHS values:** Yes, No, RoHS Exempt. See the [TI RoHS Statement](#) for additional information and value definition.

(4) **Lead finish/Ball material:** Parts may have multiple material finish options. Finish options are separated by a vertical ruled line. Lead finish/Ball material values may wrap to two lines if the finish value exceeds the maximum column width.

(5) **MSL rating/Peak reflow:** The moisture sensitivity level ratings and peak solder (reflow) temperatures. In the event that a part has multiple moisture sensitivity ratings, only the lowest level per JEDEC standards is shown. Refer to the shipping label for the actual reflow temperature that will be used to mount the part to the printed circuit board.

(6) **Part marking:** There may be an additional marking, which relates to the logo, the lot trace code information, or the environmental category of the part.

Multiple part markings will be inside parentheses. Only one part marking contained in parentheses and separated by a "-" will appear on a part. If a line is indented then it is a continuation of the previous line and the two combined represent the entire part marking for that device.

**Important Information and Disclaimer:** The information provided on this page represents TI's knowledge and belief as of the date that it is provided. TI bases its knowledge and belief on information provided by third parties, and makes no representation or warranty as to the accuracy of such information. Efforts are underway to better integrate information from third parties. TI has taken and continues to take reasonable steps to provide representative and accurate information but may not have conducted destructive testing or chemical analysis on incoming materials and chemicals. TI and TI suppliers consider certain information to be proprietary, and thus CAS numbers and other limited information may not be available for release.

In no event shall TI's liability arising out of such information exceed the total purchase price of the TI part(s) at issue in this document sold by TI to Customer on an annual basis.

#### OTHER QUALIFIED VERSIONS OF SN74LVC2T45 :

- Automotive : [SN74LVC2T45-Q1](#)
- Enhanced Product : [SN74LVC2T45-EP](#)

NOTE: Qualified Version Definitions:

- Automotive - Q100 devices qualified for high-reliability automotive applications targeting zero defects
- Enhanced Product - Supports Defense, Aerospace and Medical Applications

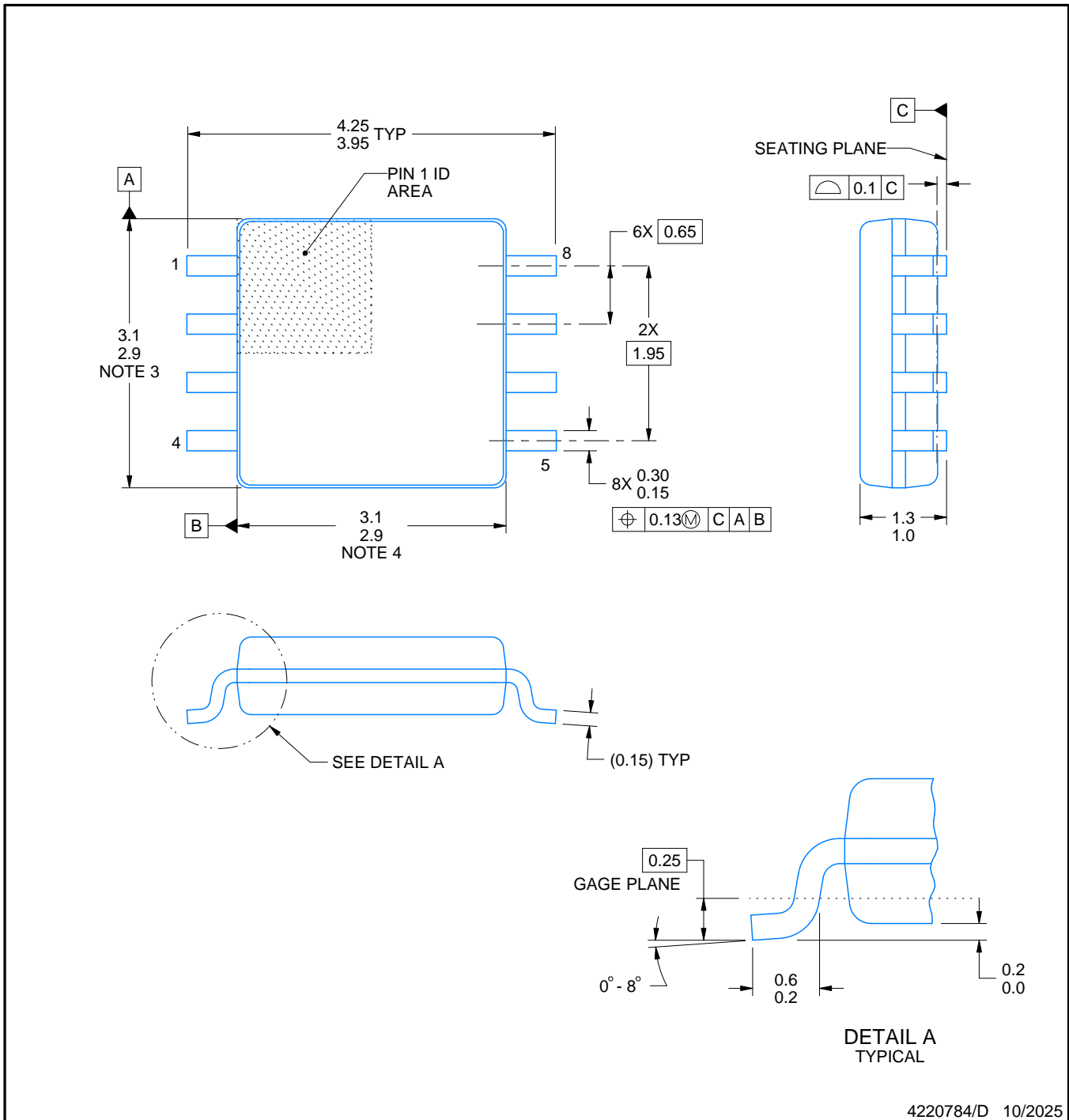
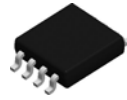

4220784/D 10/2025

NOTES:

1. All linear dimensions are in millimeters. Dimensions in parenthesis are for reference only. Dimensioning and tolerancing per ASME Y14.5M.
2. This drawing is subject to change without notice.
3. This dimension does not include mold flash, protrusions, or gate burrs. Mold flash, protrusions, or gate burrs shall not exceed 0.15 mm per side.
4. This dimension does not include interlead flash. Interlead flash shall not exceed 0.25 mm per side.

# EXAMPLE BOARD LAYOUT

DCT0008A

SSOP - 1.3 mm max height

SMALL OUTLINE PACKAGE

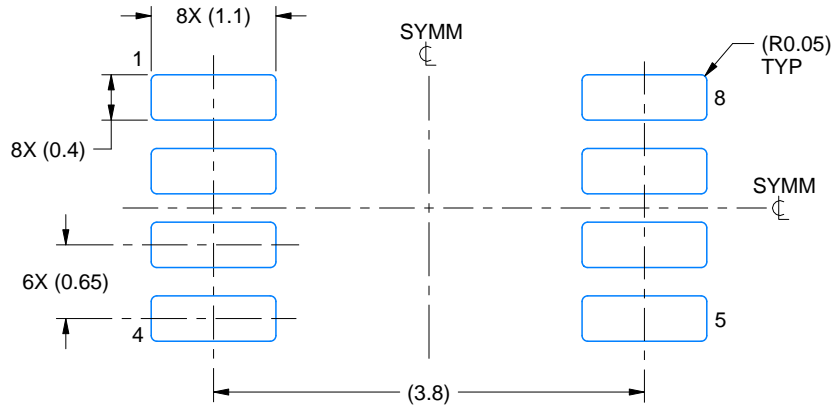

LAND PATTERN EXAMPLE  
EXPOSED METAL SHOWN  
SCALE:15X

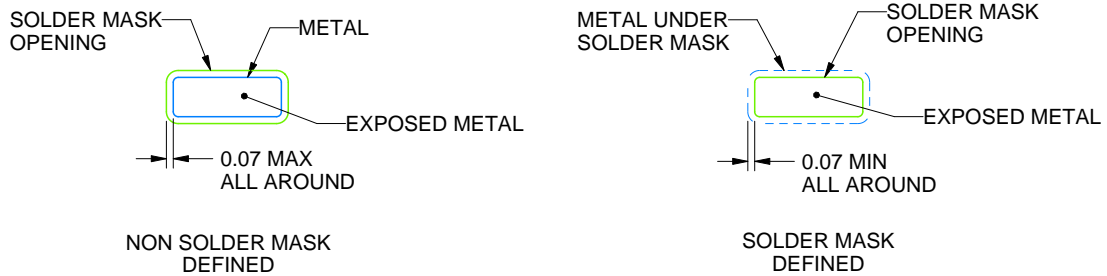

SOLDER MASK DETAILS

4220784/D 10/2025

NOTES: (continued)

- 5. Publication IPC-7351 may have alternate designs.
- 6. Solder mask tolerances between and around signal pads can vary based on board fabrication site.

# EXAMPLE STENCIL DESIGN

DCT0008A

SSOP - 1.3 mm max height

SMALL OUTLINE PACKAGE

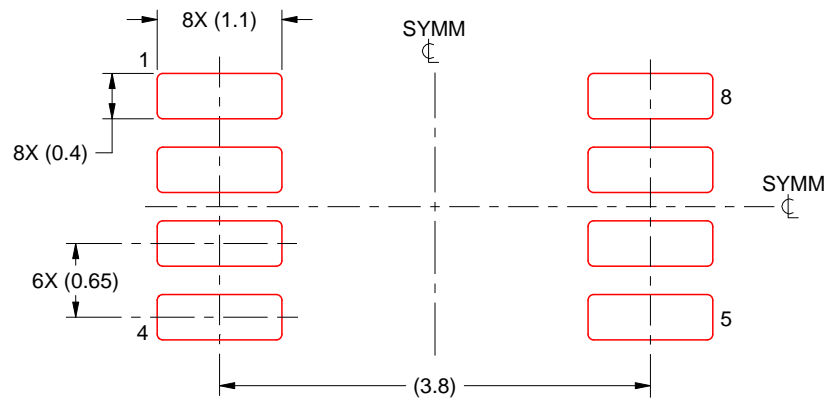

SOLDER PASTE EXAMPLE  
BASED ON 0.125 mm THICK STENCIL  
SCALE:15X

4220784/D 10/2025

NOTES: (continued)

7. Laser cutting apertures with trapezoidal walls and rounded corners may offer better paste release. IPC-7525 may have alternate design recommendations.
8. Board assembly site may have different recommendations for stencil design.

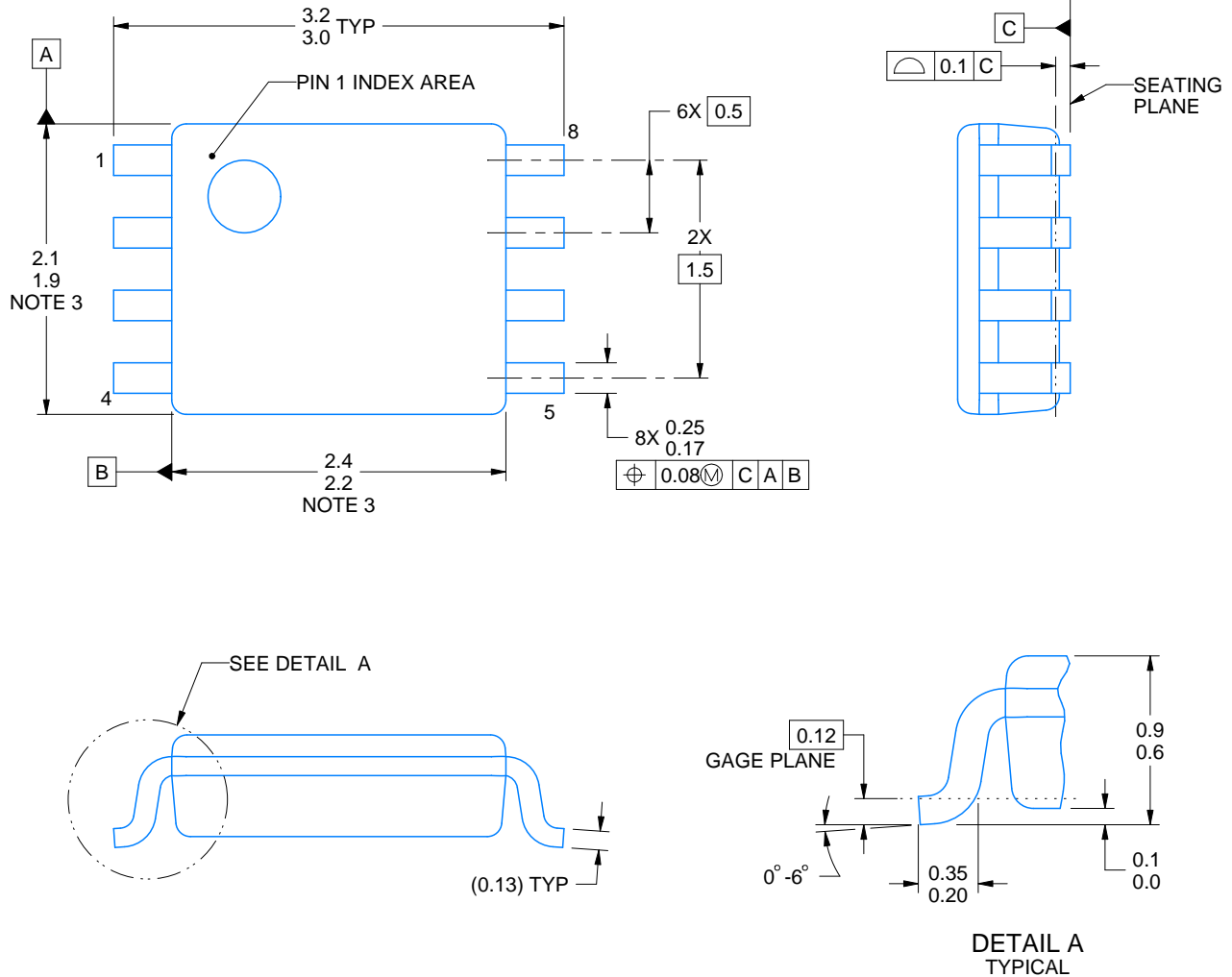

4225266/A 09/2014

NOTES:

1. All linear dimensions are in millimeters. Any dimensions in parenthesis are for reference only. Dimensioning and tolerancing per ASME Y14.5M.
2. This drawing is subject to change without notice.
3. This dimension does not include mold flash, protrusions, or gate burrs. Mold flash, protrusions, or gate burrs shall not exceed 0.15 mm per side.
4. Reference JEDEC registration MO-187 variation CA.

# EXAMPLE BOARD LAYOUT

DCU0008A

VSSOP - 0.9 mm max height

SMALL OUTLINE PACKAGE

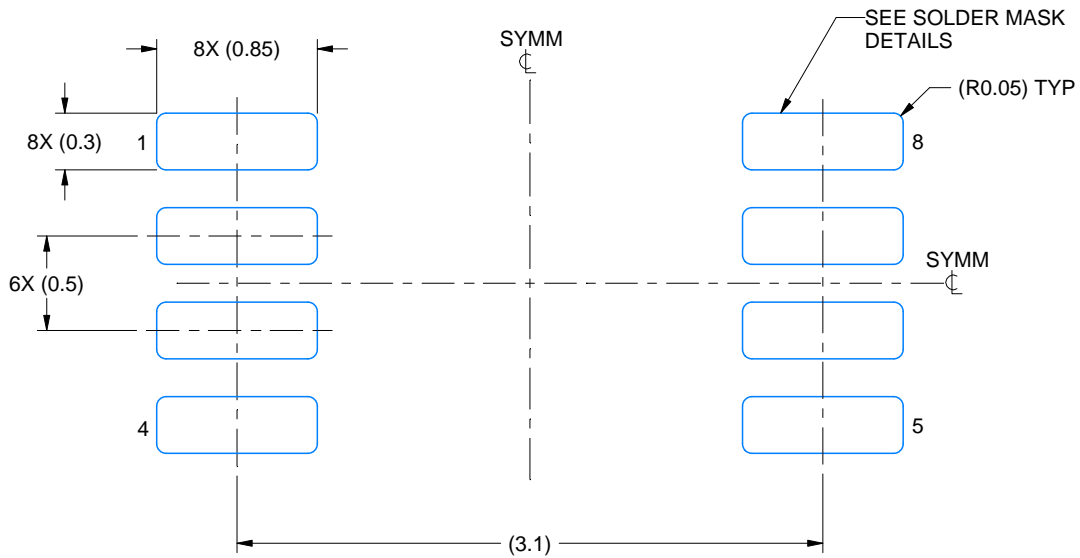

LAND PATTERN EXAMPLE  
EXPOSED METAL SHOWN  
SCALE: 25X

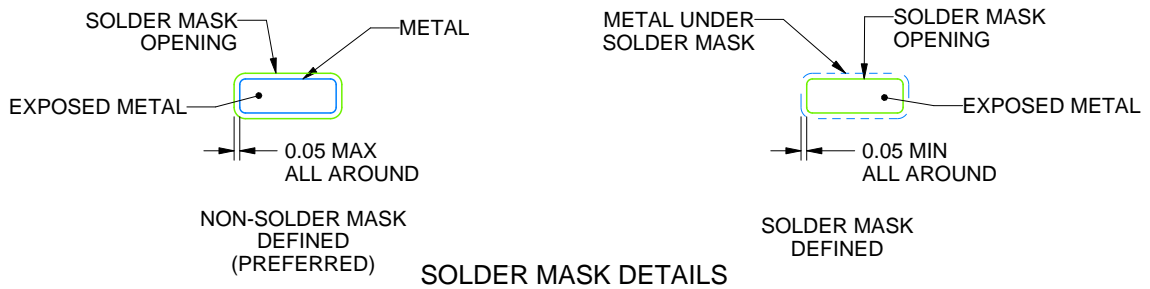

4225266/A 09/2014

NOTES: (continued)

- 5. Publication IPC-7351 may have alternate designs.
- 6. Solder mask tolerances between and around signal pads can vary based on board fabrication site.

# EXAMPLE STENCIL DESIGN

DCU0008A

VSSOP - 0.9 mm max height

SMALL OUTLINE PACKAGE

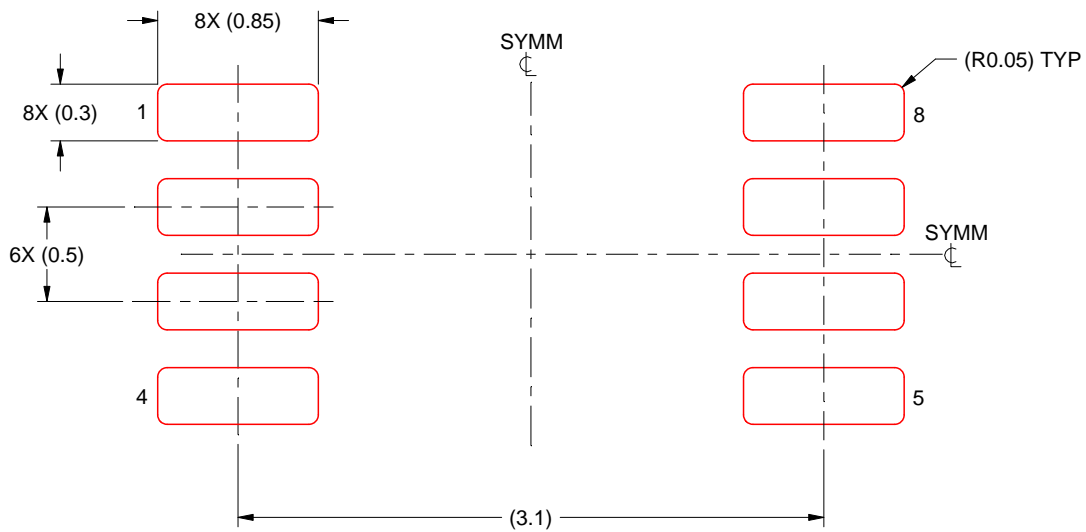

SOLDER PASTE EXAMPLE  
BASED ON 0.125 mm THICK STENCIL  
SCALE: 25X

4225266/A 09/2014

NOTES: (continued)

7. Laser cutting apertures with trapezoidal walls and rounded corners may offer better paste release. IPC-7525 may have alternate design recommendations.
8. Board assembly site may have different recommendations for stencil design.

YEP (R-XBGA-N8)

DIE-SIZE BALL GRID ARRAY

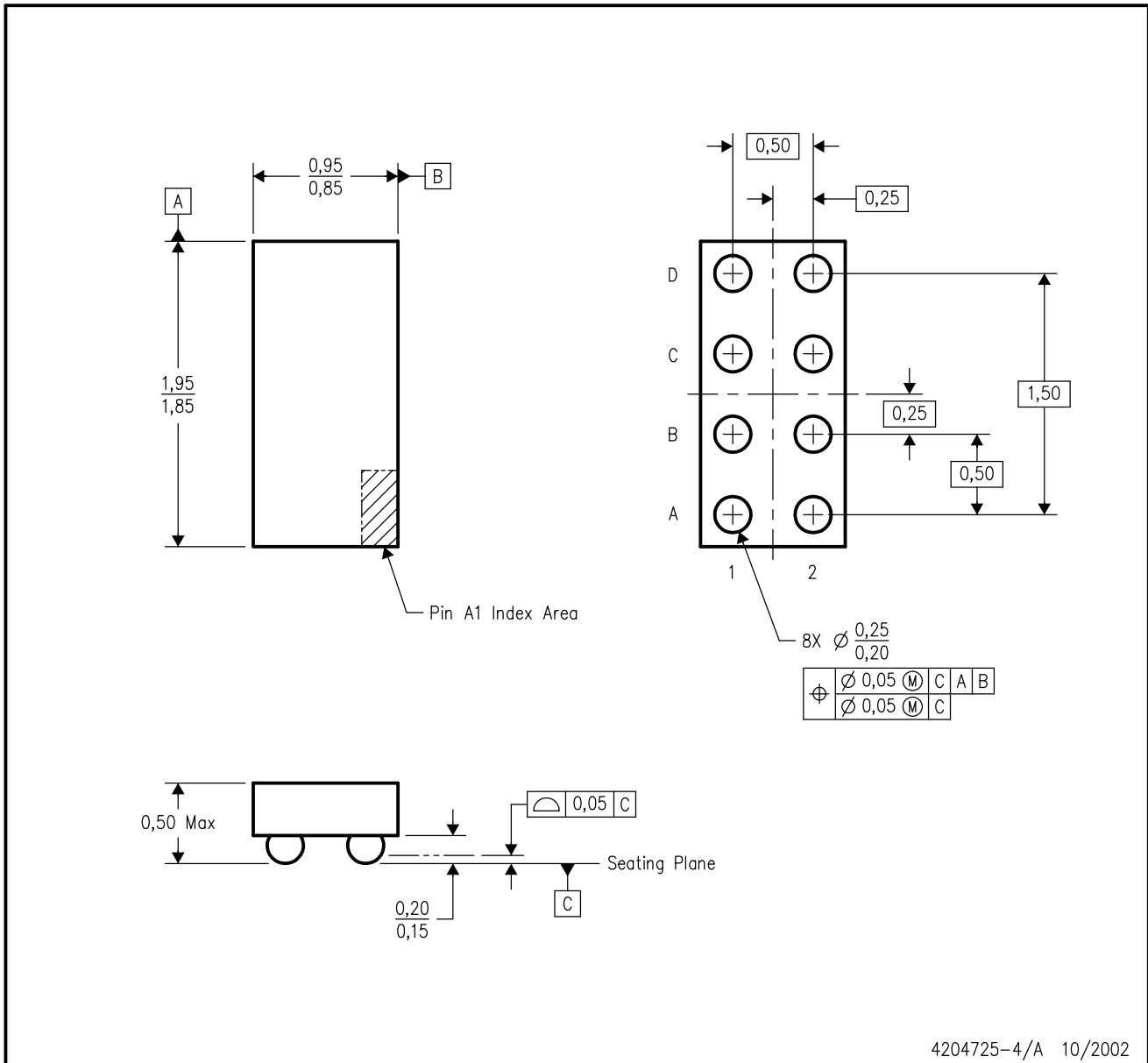

- NOTES:
- A. All linear dimensions are in millimeters.
  - B. This drawing is subject to change without notice.
  - C. NanoStar™ package configuration.
  - D. This package is tin-lead (SnPb). Refer to the 8 YZP package (drawing 4204741) for lead-free.

NanoStar is a trademark of Texas Instruments.

YZP0008

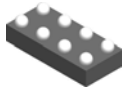

# PACKAGE OUTLINE

DSBGA - 0.5 mm max height

DIE SIZE BALL GRID ARRAY

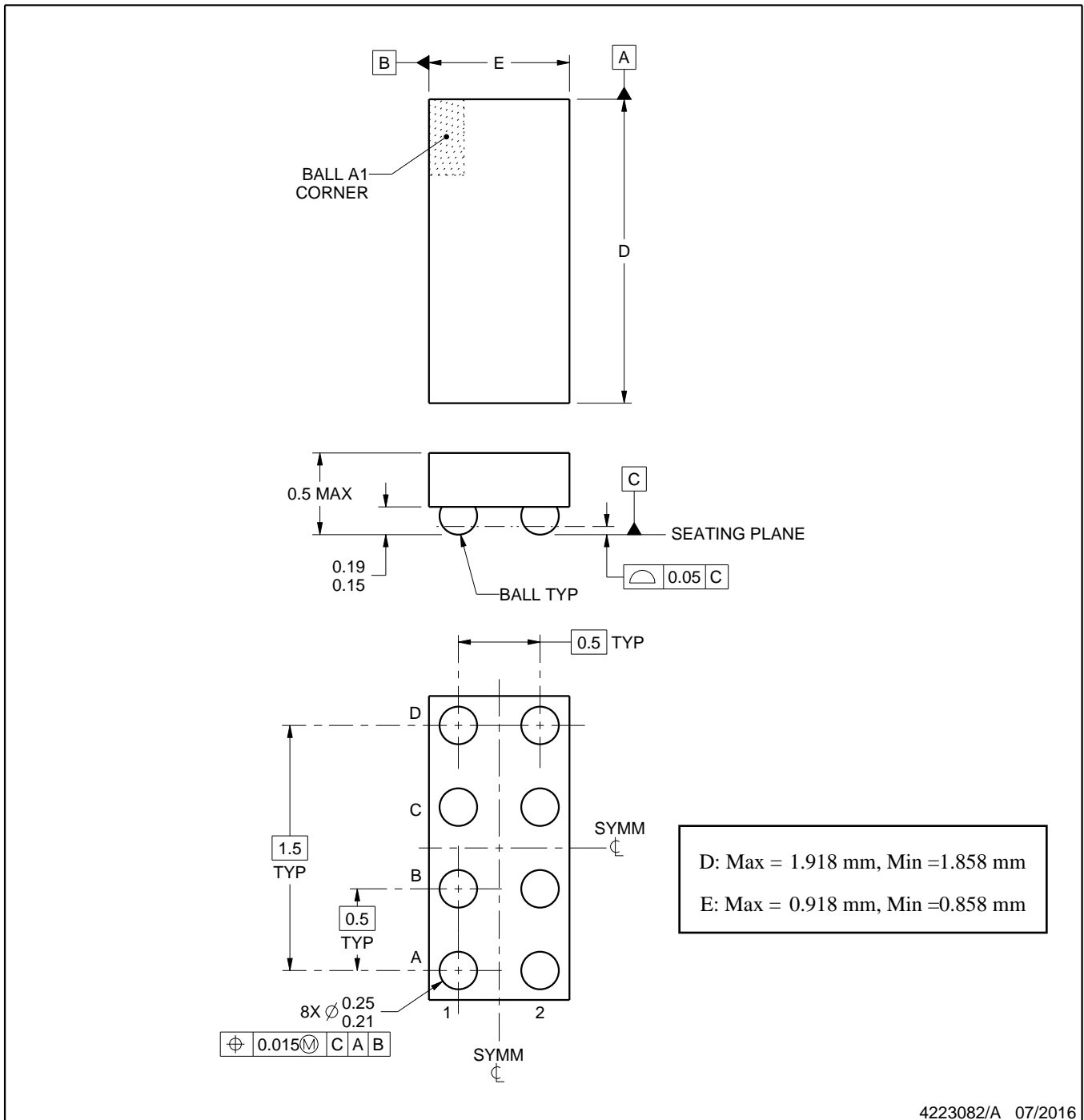

NOTES:

1. All linear dimensions are in millimeters. Any dimensions in parenthesis are for reference only. Dimensioning and tolerancing per ASME Y14.5M.
2. This drawing is subject to change without notice.

# EXAMPLE BOARD LAYOUT

YZP0008

DSBGA - 0.5 mm max height

DIE SIZE BALL GRID ARRAY

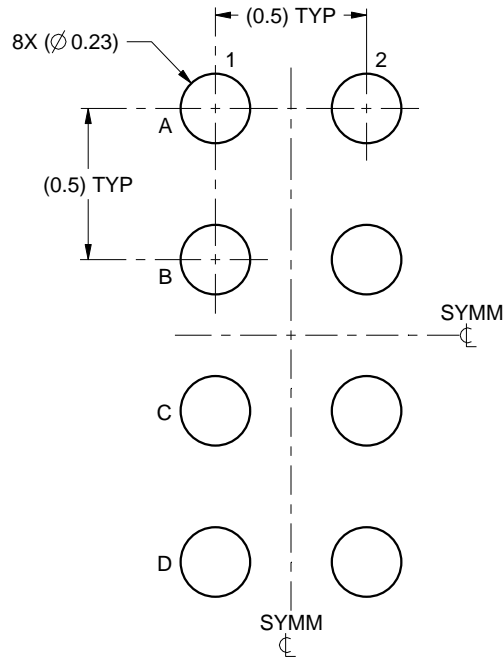

LAND PATTERN EXAMPLE  
SCALE:40X

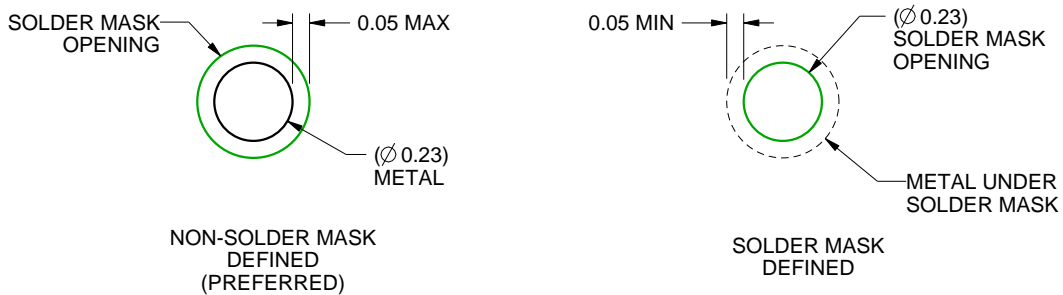

SOLDER MASK DETAILS  
NOT TO SCALE

4223082/A 07/2016

NOTES: (continued)

3. Final dimensions may vary due to manufacturing tolerance considerations and also routing constraints. For more information, see Texas Instruments literature number SNVA009 ([www.ti.com/lit/snva009](http://www.ti.com/lit/snva009)).

# EXAMPLE STENCIL DESIGN

YZP0008

DSBGA - 0.5 mm max height

DIE SIZE BALL GRID ARRAY

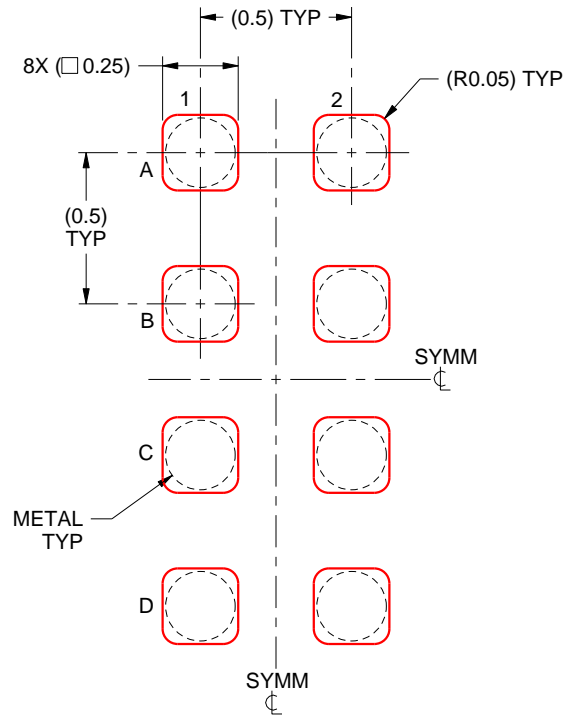

SOLDER PASTE EXAMPLE  
BASED ON 0.1 mm THICK STENCIL  
SCALE:40X

4223082/A 07/2016

NOTES: (continued)

4. Laser cutting apertures with trapezoidal walls and rounded corners may offer better paste release.

# MECHANICAL DATA

YZT (R-XBGA-N8)

DIE-SIZE BALL GRID ARRAY

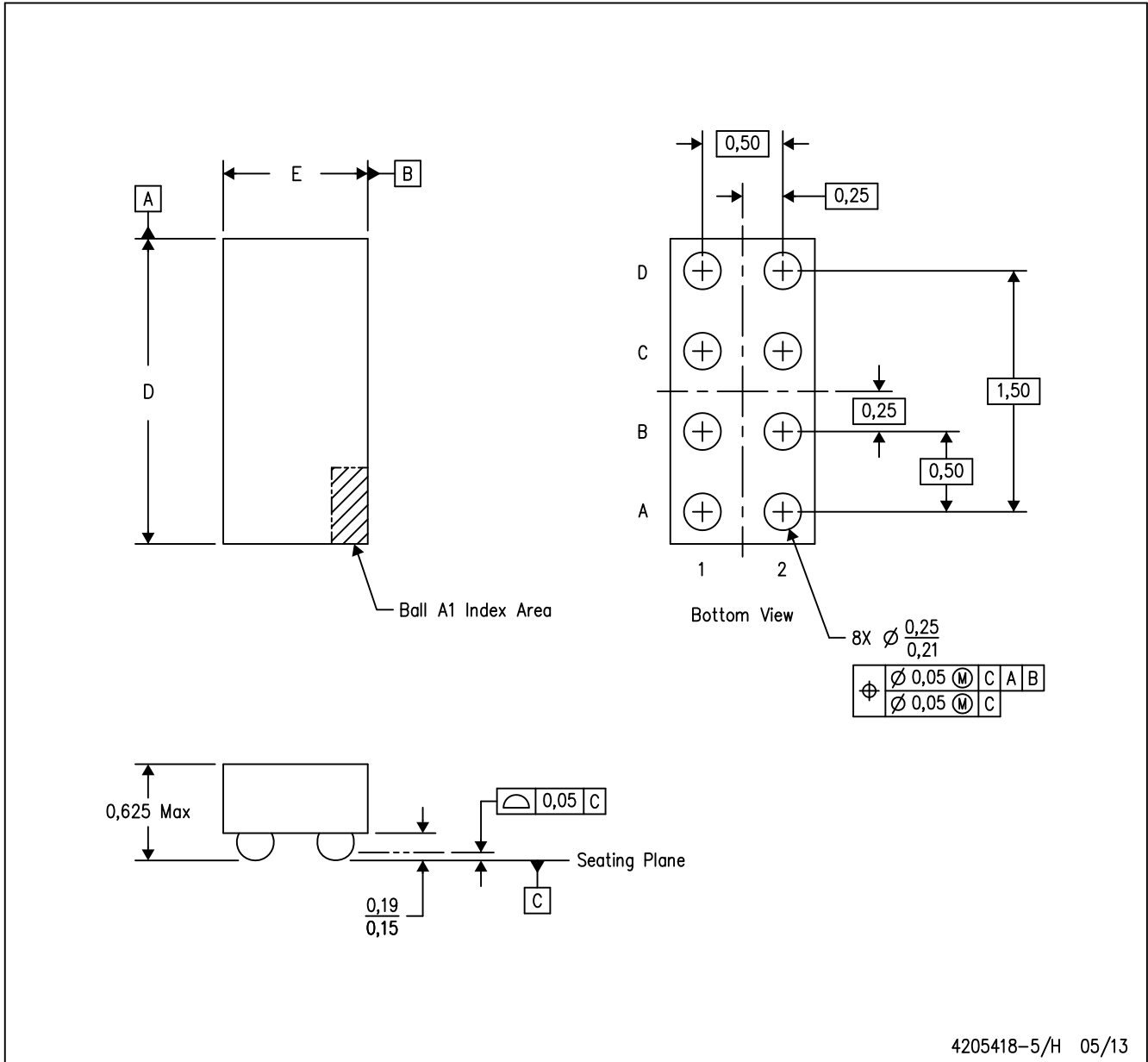

- NOTES:
- A. All linear dimensions are in millimeters. Dimensioning and tolerancing per ASME Y14.5M-1994.
  - B. This drawing is subject to change without notice.
  - C. NanoFree™ package configuration.

NanoFree is a trademark of Texas Instruments.

## IMPORTANT NOTICE AND DISCLAIMER

TI PROVIDES TECHNICAL AND RELIABILITY DATA (INCLUDING DATASHEETS), DESIGN RESOURCES (INCLUDING REFERENCE DESIGNS), APPLICATION OR OTHER DESIGN ADVICE, WEB TOOLS, SAFETY INFORMATION, AND OTHER RESOURCES "AS IS" AND WITH ALL FAULTS, AND DISCLAIMS ALL WARRANTIES, EXPRESS AND IMPLIED, INCLUDING WITHOUT LIMITATION ANY IMPLIED WARRANTIES OF MERCHANTABILITY, FITNESS FOR A PARTICULAR PURPOSE OR NON-INFRINGEMENT OF THIRD PARTY INTELLECTUAL PROPERTY RIGHTS.

These resources are intended for skilled developers designing with TI products. You are solely responsible for (1) selecting the appropriate TI products for your application, (2) designing, validating and testing your application, and (3) ensuring your application meets applicable standards, and any other safety, security, regulatory or other requirements.

These resources are subject to change without notice. TI grants you permission to use these resources only for development of an application that uses the TI products described in the resource. Other reproduction and display of these resources is prohibited. No license is granted to any other TI intellectual property right or to any third party intellectual property right. TI disclaims responsibility for, and you fully indemnify TI and its representatives against any claims, damages, costs, losses, and liabilities arising out of your use of these resources.

TI's products are provided subject to [TI's Terms of Sale](#), [TI's General Quality Guidelines](#), or other applicable terms available either on [ti.com](http://ti.com) or provided in conjunction with such TI products. TI's provision of these resources does not expand or otherwise alter TI's applicable warranties or warranty disclaimers for TI products. Unless TI explicitly designates a product as custom or customer-specified, TI products are standard, catalog, general purpose devices.

TI objects to and rejects any additional or different terms you may propose.

Copyright © 2026, Texas Instruments Incorporated

Last updated 10/2025