

# TYPES TIP32, TIP32A, TIP32B, TIP32C P-N-P SINGLE-DIFFUSED MESA SILICON POWER TRANSISTORS

FOR POWER-AMPLIFIER AND HIGH-SPEED-SWITCHING APPLICATIONS  
DESIGNED FOR COMPLEMENTARY USE WITH TIP31, TIP31A, TIP31B, TIP31C

- 40 W at 25°C Case Temperature
- 3 A Rated Collector Current
- Min  $f_T$  of 3 MHz at 10 V, 500 mA

## mechanical data

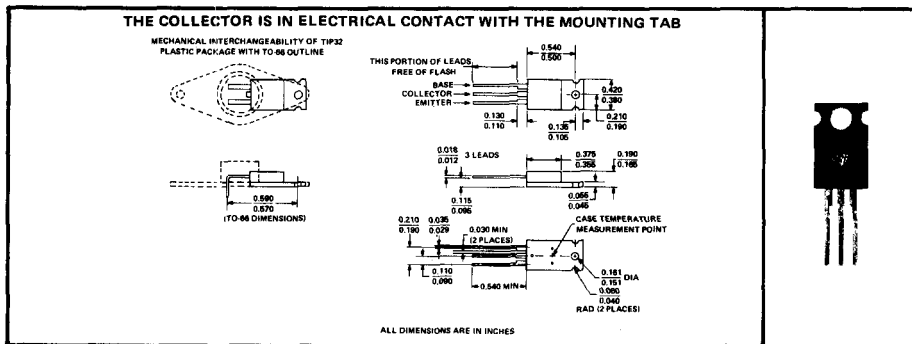

## absolute maximum ratings at 25°C case temperature (unless otherwise noted)

	TIP32	TIP32A	TIP32B	TIP32C
Collector-Base Voltage	-40 V	-60 V	-80 V	-100 V
Collector-Emitter Voltage (See Note 1)	-40 V	-60 V	-80 V	-100 V
Emitter-Base Voltage	← -5 V →			
Continuous Collector Current	← -3 A →			
Peak Collector Current (See Note 2)	← -5 A →			
Continuous Base Current	← -1 A →			
Safe Operating Region at (or below) 25°C Case Temperature	← See Figure 5 →			
Continuous Device Dissipation at (or below) 25°C Case Temperature (See Note 3)	← 40 W →			
Continuous Device Dissipation at (or below) 25°C Free-Air Temperature (See Note 4)	← 2 W →			
Unclamped Inductive Load Energy (See Note 5)	← 32 mJ →			
Operating Collector Junction Temperature Range	← -65°C to 150°C →			
Storage Temperature Range	← -65°C to 150°C →			
Lead Temperature 1/8 Inch from Case for 10 Seconds	← 260°C →			

- NOTES: 1. This value applies when the base-emitter diode is open-circuited.  
 2. This value applies for  $t_w < 0.3$  ms, duty cycle  $< 10\%$ .  
 3. Derate linearly to 150°C case temperature at the rate of 0.32 W/°C.  
 4. Derate linearly to 150°C free-air temperature at the rate of 16 mW/°C.  
 5. This rating is based on the capability of the transistor to operate safely in the circuit of Figure 2. L = 20 mH,  $R_{BB2} = 100 \Omega$ ,  $V_{BB2} = 0$  V,  $R_S = 0.1 \Omega$ ,  $V_{CC} = 10$  V. Energy  $\approx I_C^2 L/2$ .

# TYPES TIP32, TIP32A, TIP32B, TIP32C

## P-N-P SINGLE-DIFFUSED MESA SILICON POWER TRANSISTORS

electrical characteristics at 25°C case temperature

PARAMETER	TEST CONDITIONS	TIP32		TIP32A		TIP32B		TIP32C		UNIT
		MIN	MAX	MIN	MAX	MIN	MAX	MIN	MAX	
$V_{(BR)CEO}$	Collector-Emitter Breakdown Voltage $I_C = -30 \text{ mA}$ , $I_B = 0$ , See Note 6	-40		-60		-80		-100		V
$I_{CEO}$	Collector Cutoff Current $V_{CE} = -30 \text{ V}$ , $I_B = 0$	-0.3		-0.3						mA
	$V_{CE} = -60 \text{ V}$ , $I_B = 0$					-0.3		-0.3		
$I_{CES}$	Collector Cutoff Current $V_{CE} = -40 \text{ V}$ , $V_{BE} = 0$	-0.2								mA
	$V_{CE} = -60 \text{ V}$ , $V_{BE} = 0$			-0.2						
	$V_{CE} = -80 \text{ V}$ , $V_{BE} = 0$					-0.2				
	$V_{CE} = -100 \text{ V}$ , $V_{BE} = 0$							-0.2		
$I_{EBO}$	Emitter Cutoff Current $V_{EB} = -5 \text{ V}$ , $I_C = 0$	-1		-1		-1		-1		mA
$h_{FE}$	Static Forward Current Transfer Ratio $V_{CE} = -4 \text{ V}$ , $I_C = -1 \text{ A}$ , See Notes 6 and 7	25		25		25		25		
	$V_{CE} = -4 \text{ V}$ , $I_C = -3 \text{ A}$ , See Notes 6 and 7	10	50	10	50	10	50	10	50	
$V_{BE}$	Base-Emitter Voltage $V_{CE} = -4 \text{ V}$ , $I_C = -3 \text{ A}$ , See Notes 6 and 7	-1.8		-1.8		-1.8		-1.8		V
$V_{CE(sat)}$	Collector-Emitter Saturation Voltage $I_B = -375 \text{ mA}$ , $I_C = -3 \text{ A}$ , See Notes 6 and 7	-1.2		-1.2		-1.2		-1.2		V
$h_{fe}$	Small-Signal Common-Emitter Forward Current Transfer Ratio $V_{CE} = -10 \text{ V}$ , $I_C = -0.5 \text{ A}$ , $f = 1 \text{ kHz}$	20		20		20		20		
$ h_{fe} $	Small-Signal Common-Emitter Forward Current Transfer Ratio $V_{CE} = -10 \text{ V}$ , $I_C = -0.5 \text{ A}$ , $f = 1 \text{ MHz}$	3		3		3		3		

- NOTES: 6. These parameters must be measured using pulse techniques.  $t_w = 300 \mu\text{s}$ , duty cycle  $\leq 2\%$ .  
7. These parameters are measured with voltage-sensing contacts separate from the current-carrying contacts.

### thermal characteristics

PARAMETER	MAX	UNIT
$R_{\theta JC}$ Junction-to-Case Thermal Resistance	3.125	°C/W
$R_{\theta JA}$ Junction-to-Free-Air Thermal Resistance	62.5	

### switching characteristics at 25°C case temperature

PARAMETER	TEST CONDITIONS†	TYP	UNIT
$t_{on}$ Turn-On Time	$I_C = -1 \text{ A}$ , $I_{B(1)} = -100 \text{ mA}$ , $I_{B(2)} = 100 \text{ mA}$ , $V_{BE(off)} = 4.3 \text{ V}$ , $R_L = 30 \Omega$ . See Figure 1	0.3	$\mu\text{s}$
$t_{off}$ Turn-Off Time		1.0	

† Voltages and current values shown are nominal; exact values vary slightly with transistor parameters.

# TYPES TIP32, TIP32A, TIP32B, TIP32C P-N-P SINGLE-DIFFUSED MESA SILICON POWER TRANSISTORS

## PARAMETER MEASUREMENT INFORMATION

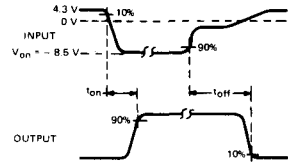
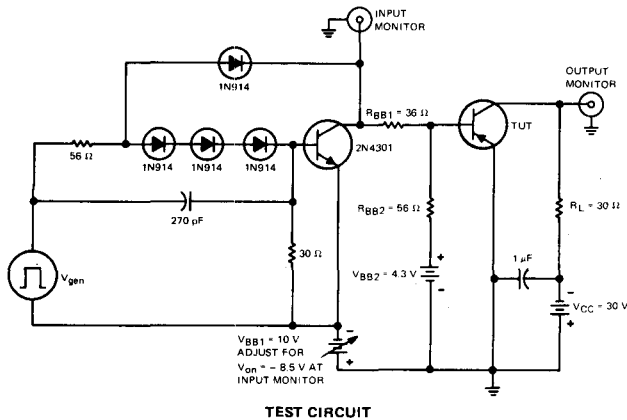

TEST CIRCUIT

VOLTAGE WAVEFORMS

- NOTES: A.  $V_{gen}$  is a 30-V pulse (from 0 V) into a 50- $\Omega$  termination.  
 B. The  $V_{gen}$  waveform is supplied by a generator with the following characteristics:  $t_r \leq 15$  ns,  $t_f \leq 15$  ns,  $Z_{out} = 50$   $\Omega$ ,  $t_w = 20$   $\mu$ s, duty cycle  $\leq 2\%$ .  
 C. Waveforms are monitored on an oscilloscope with the following characteristics:  $t_r \leq 15$  ns,  $R_{in} \geq 10$  M $\Omega$ ,  $C_{in} \leq 11.5$  pF.  
 D. Resistors must be noninductive types.  
 E. The d-c power supplies may require additional bypassing in order to minimize ringing.

FIGURE 1

## INDUCTIVE LOAD SWITCHING

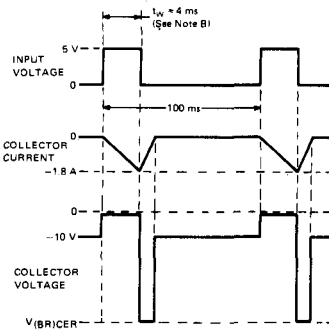
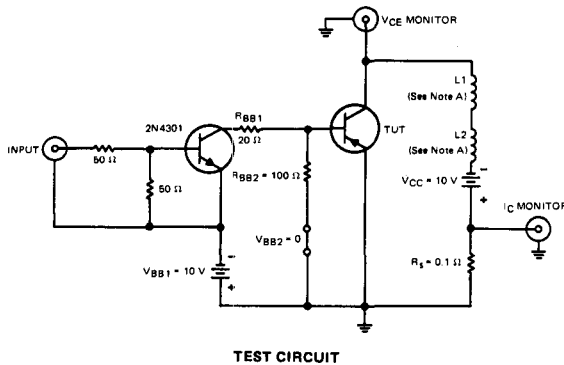

TEST CIRCUIT

VOLTAGE AND CURRENT WAVEFORMS

- NOTES: A. L1 and L2 are 10 mH, 0.11  $\Omega$ , Chicago Standard Transformer Corporation C-2688, or equivalent.  
 B. Input pulse width is increased until  $I_{CM} = -1.8$  A.

FIGURE 2

# TYPES TIP32, TIP32A, TIP32B, TIP32C

## P-N-P SINGLE-DIFFUSED MESA SILICON POWER TRANSISTORS

### TYPICAL CHARACTERISTICS

STATIC FORWARD CURRENT TRANSFER RATIO  
vs  
COLLECTOR CURRENT

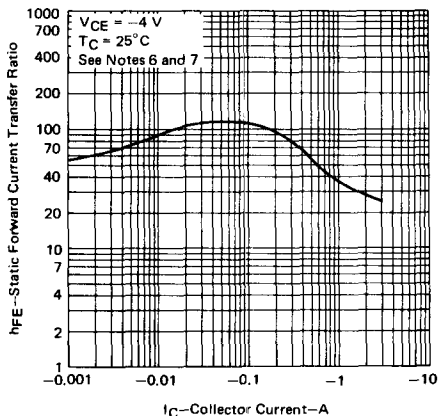

FIGURE 3

### THERMAL INFORMATION

DISSIPATION DERATING CURVE

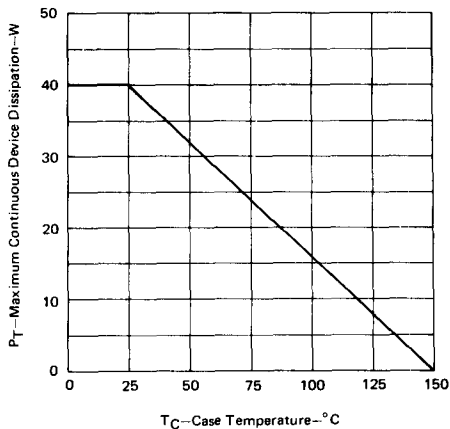

FIGURE 4

- NOTES: 6. These parameters must be measured using pulse techniques.  $t_w = 300 \mu s$ , duty cycle  $\leq 2\%$ .  
7. These parameters are measured with voltage-sensing contacts separate from the current-carrying contacts.

### MAXIMUM SAFE OPERATING REGION

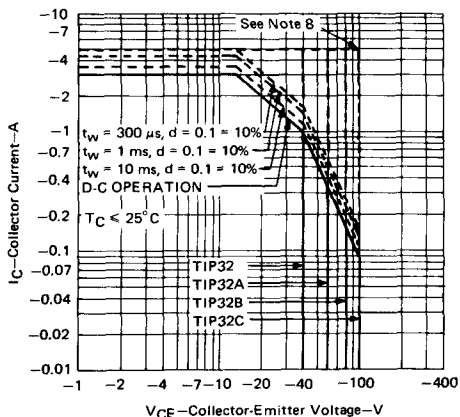

FIGURE 5

- NOTE 8: This combination of maximum voltage and current may be achieved only when switching from saturation to cutoff with a clamped inductive load.

**SILIZIUM-KOMPLEMENTARE-LEISTUNGSTRANSISTOREN  
(Allgemeine und NF-Anwendungen)**

**SILICON COMPLEMENTARY POWER TRANSISTORS  
(General and Low-frequency Applications)**

Type		$P_{tot}^{(a)}$	$V_{CE0}$	$I_{CD}$		$h_{FE}$	$I_C$
type		$T_C = 25\text{ }^\circ\text{C}$	min	max	min	max	A
NPN	PNP	(100 $^\circ\text{C}$ )		A			
		W					A
BD 239	BD 240	30	45	2	40		0,2
BD 239 A	BD 240 A	30	60	2	40		0,2
BD 239 B	BD 240 B	30	80	2	40		0,2
BD 239 C	BD 240 C	30	100	2	40		0,2
BD 241	BD 242	40	45	3	25		1
BD 241 A	BD 242 A	40	60	3	25		1
BD 241 B	BD 242 B	40	80	3	25		1
BD 241 C	BD 242 C	40	100	3	25		1
BD 243	BD 244	65	45	6	30		0,3
BD 243 A	BD 244 A	65	60	6	30		0,3
BD 243 B	BD 244 B	65	80	6	30		0,3
BD 243 C	BD 244 C	65	100	6	30		0,3
BD 245	BD 246	80	45	10	40		1
BD 245 A	BD 246 A	80	60	10	40		1
BD 245 B	BD 246 B	80	80	10	40		1
BD 245 C	BD 246 C	80	100	10	40		1
BD 249	BD 250	125	45	25	25		1,5
BD 249 A	BD 250 A	125	60	25	25		1,5
BD 249 B	BD 250 B	125	80	25	25		1,5
BD 249 C	BD 250 C	125	100	25	25		1,5
TIP 29	TIP 30	30	40	1	40	200	0,2
TIP 29 A	TIP 30 A	30	60	1	40	200	0,2
TIP 29 B	TIP 30 B	30	80	1	40	200	0,2
TIP 29 C	TIP 30 C	30	100	1	40	200	0,2
TIP 31	TIP 32	40	40	3	25	100	1
TIP 31 A	TIP 32 A	40	60	3	25	100	1
TIP 31 B	TIP 32 B	40	80	3	25	100	1
TIP 31 C	TIP 32 C	40	100	3	25	100	1
TIP 33	TIP 34	80	40	10	40	125	1
TIP 33 A	TIP 34 A	80	60	10	40	125	1
TIP 33 B	TIP 34 B	80	80	10	40	125	1
TIP 33 C	TIP 34 C	80	100	10	40	125	1
TIP 35	TIP 36	90	40	25	25	100	1,5
TIP 35 A	TIP 36 A	90	60	25	25	100	1,5

$f_T$ m n M Hz	$I_{CES}$ @ ( $I_{CEO}$ ) $\mu A$	VCE V	Gehäuse package	Anwendungen, Bemerkungen applications, remarks
			TO-66P TO-66P TO-66P TO-66P	
			TO-66P TO-66P TO-66P TO-66P	
			TO-66P TO-66P TO-66P TO-66P	Verstärker, Schalter amplifier, switch
			TO-3P TO-3P TO-3P TO-3P	
			TO-3P TO-3P TO-3P TO-3P	
3	200	40	TO-66P	Verstärker, Schalter, komplementär zu TIP 30 amplifier, switch, complementary to TIP 30
3	200	60	TO-66P	Verstärker, Schalter, komplementär zu TIP 30 A amplifier, switch, complementary to TIP 30 A
3	200	80	TO-66P	Verstärker, Schalter, komplementär zu TIP 30 B amplifier, switch, complementary to TIP 30 B
3	200	100	TO-66P	Verstärker, Schalter, komplementär zu TIP 30 C amplifier, switch, complementary to TIP 30 C
3	300	40	TO-66P	Verstärker, Schalter, komplementär zu TIP 32 amplifier, switch, complementary to TIP 32
3	300	60	TO-3P	Verstärker, Schalter, komplementär zu TIP 32 A amplifier, switch, complementary to TIP 32 A
3	300	80	TO-3P	Verstärker, Schalter, komplementär zu TIP 32 B amplifier, switch, complementary to TIP 32 B
3	300	100	TO-3P	Verstärker, Schalter, komplementär zu TIP 32 C amplifier, switch, complementary to TIP 32 C
3	400	40	TO-3P	Verstärker, Schalter, komplementär zu TIP 34 amplifier, switch, complementary to TIP 34
3	400	60	TO-3P	Verstärker, Schalter, komplementär zu TIP 34 A amplifier, switch, complementary to TIP 34 A
3	400	80	TO-3P	Verstärker, Schalter, komplementär zu TIP 34 B amplifier, switch, complementary to TIP 34 B
3	400	100	TO-3P	Verstärker, Schalter, komplementär zu TIP 34 C amplifier, switch, complementary to TIP 34 C
3	700	40	TO-3P	Verstärker, Schalter, komplementär zu TIP 36 amplifier, switch, complementary to TIP 36
3	700	60	TO-3P	Verstärker, Schalter, komplementär zu TIP 36 A amplifier, switch, complementary to TIP 36 A