

---

## TMS320F28PLC8x Power Line Communications (PLC) Processors

---

### 1 Device Overview

#### 1.1 Features

- System-on-Chip for Power Line Communications
  - Supports PLC Networks Using G3-PLC, PRIME, IEEE-1901.2, ITU G.9903, ITU G.9904 Standards in the CENELEC Frequency Band (35 kHz–90 kHz)
  - Designed to Operate With the AFE031 Analog Front End (AFE) for PLC
- Supports Texas Instruments PLC Software
  - IEEE 1901.2
  - ITU G.9903
  - ITU G.9904
  - PRIME
  - G3-PLC
- TMS320F28PLC84 Includes Key G3-PLC Firmware Routines Loaded into On-chip ROM
  - Opens On-chip Flash Memory for Future Firmware Enhancements
- 32-Bit C28x CPU Architecture Optimized for Orthogonal Frequency-Division Multiplex (OFDM) Communications
  - Viterbi/Complex Math Unit (VCU)
  - 90 MHz
- On-chip Memory
  - 256KB of Flash
  - 100KB of RAM
  - Boot ROM
- Power Supply
  - Single 3.3-V Power Supply
  - Option to Disable On-chip Low-Dropout (LDO) Regulator and Supply 1.8-V Core Voltage With External Regulator
- Communications Peripherals
  - Two Serial Peripheral Interface (SPI) Ports
  - Two Serial Communications Interface (SCI) Ports
  - One Multichannel Buffered Serial Port (McBSP)
    - McBSP Port can Also be Used as SPI
  - One Inter-Integrated-Circuit (I<sup>2</sup>C) Port
- Analog Subsystem
  - 12-Bit Analog-to-Digital Converters (ADCs), Each With Dual Sample-and-Hold (S/H)
  - ADC Operates at 3.4 MSPS
- 128-Bit Security Key and Lock
  - Protects Secure Memory Blocks
  - Prevents Firmware Reverse Engineering
  - Blocks JTAG Access When Enabled
- 80-Pin PN Low-Profile Quad Flatpack (LQFP)
- Industrial Temperature Range: –40°C to 105°C

#### 1.2 Applications

- Electric Meters
- Power Line Communications Data Concentrators
- Solar Inverters



### 1.3 Description

The Texas Instruments TMS320F28PLC8x PLC processors are optimized to meet the requirements for AMI networks in Smart Grid installations that will use narrowband power line communications in the CENELEC frequency band. The CENELEC band is defined to be 35 kHz to 90 kHz.

The F28PLC8x processors are designed to execute the entire PLC protocol stack for the supported industry standards. TI supplies these firmware libraries to execute on the F28PLC8x processors with no additional license fees or royalties.

The F28PLC8x processors are also used in PLC data concentrators, which act as neighborhood-area collectors of electricity usage information from multiple end nodes.

The F28PLC8x processors are optimized to work with the AFE031 analog front end for PLC. The AFE031 is an integrated analog front end for narrowband PLC that is capable of driving a transformer-coupled connection to the AC Mains power line. It is ideal for driving high-current, low-impedance lines driving up to 1.9 A into reactive loads. The AFE031 is compliant to CENELEC A, B, C, and D (EN50065-1, -2, -3, -7) frequency bands.

See [Section 7.1.1.2](#) for a list of reference designs, starter kits, and tools.

**Device Information<sup>(1)</sup>**

PART NUMBER	PACKAGE	BODY SIZE
TMS320F28PLC84PN	LQFP (80)	12.0 mm x 12.0 mm
TMS320F28PLC83PN	LQFP (80)	12.0 mm x 12.0 mm

(1) For more information on these devices, see [Section 8](#), Mechanical Packaging and Orderable Information.

### 1.4 Functional Block Diagram

Figure 1-1 shows a functional block diagram of the device.

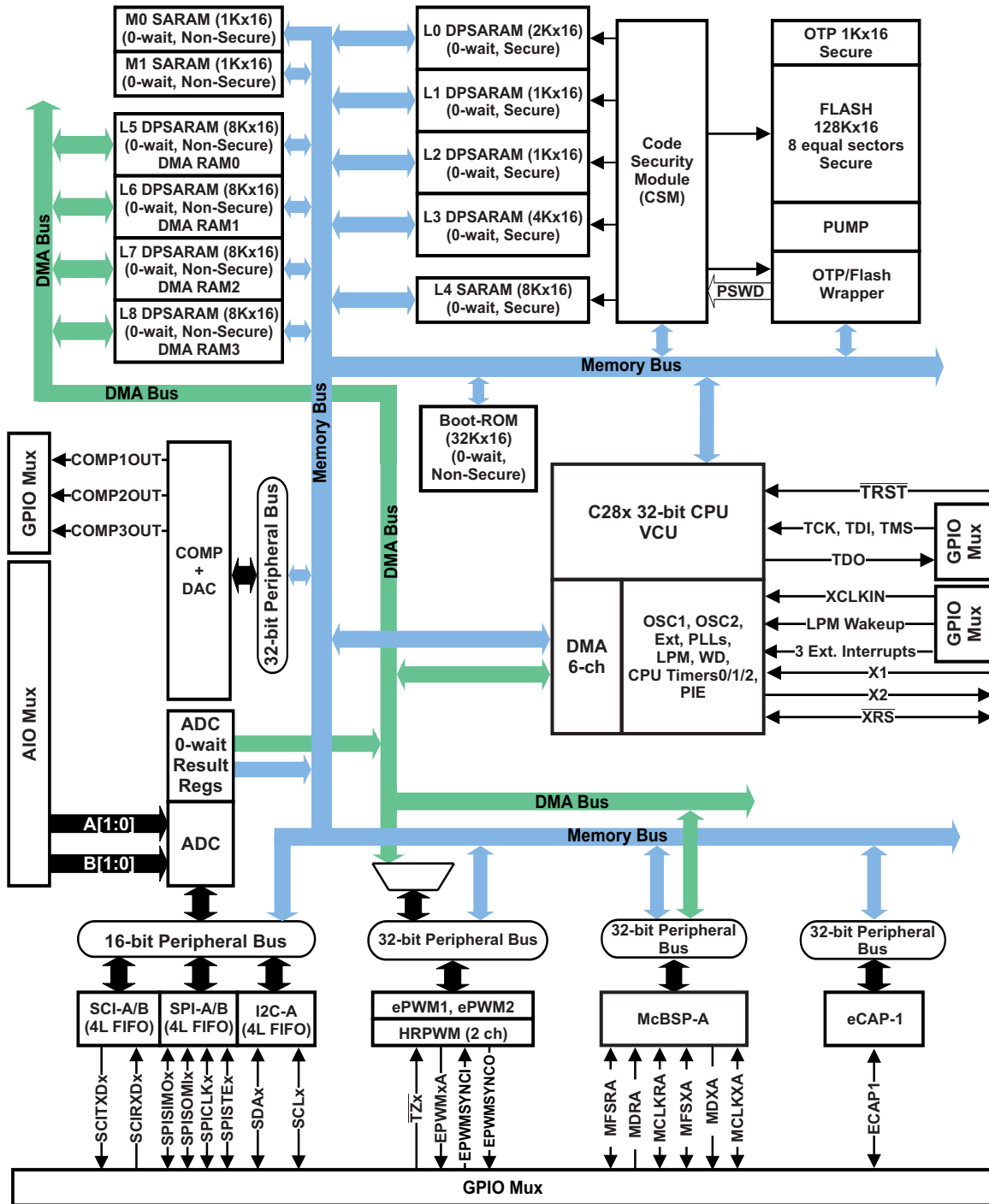

A. Not all peripheral pins are available at the same time due to multiplexing.

Figure 1-1. Functional Block Diagram

### 1.5 Additional Block Diagrams

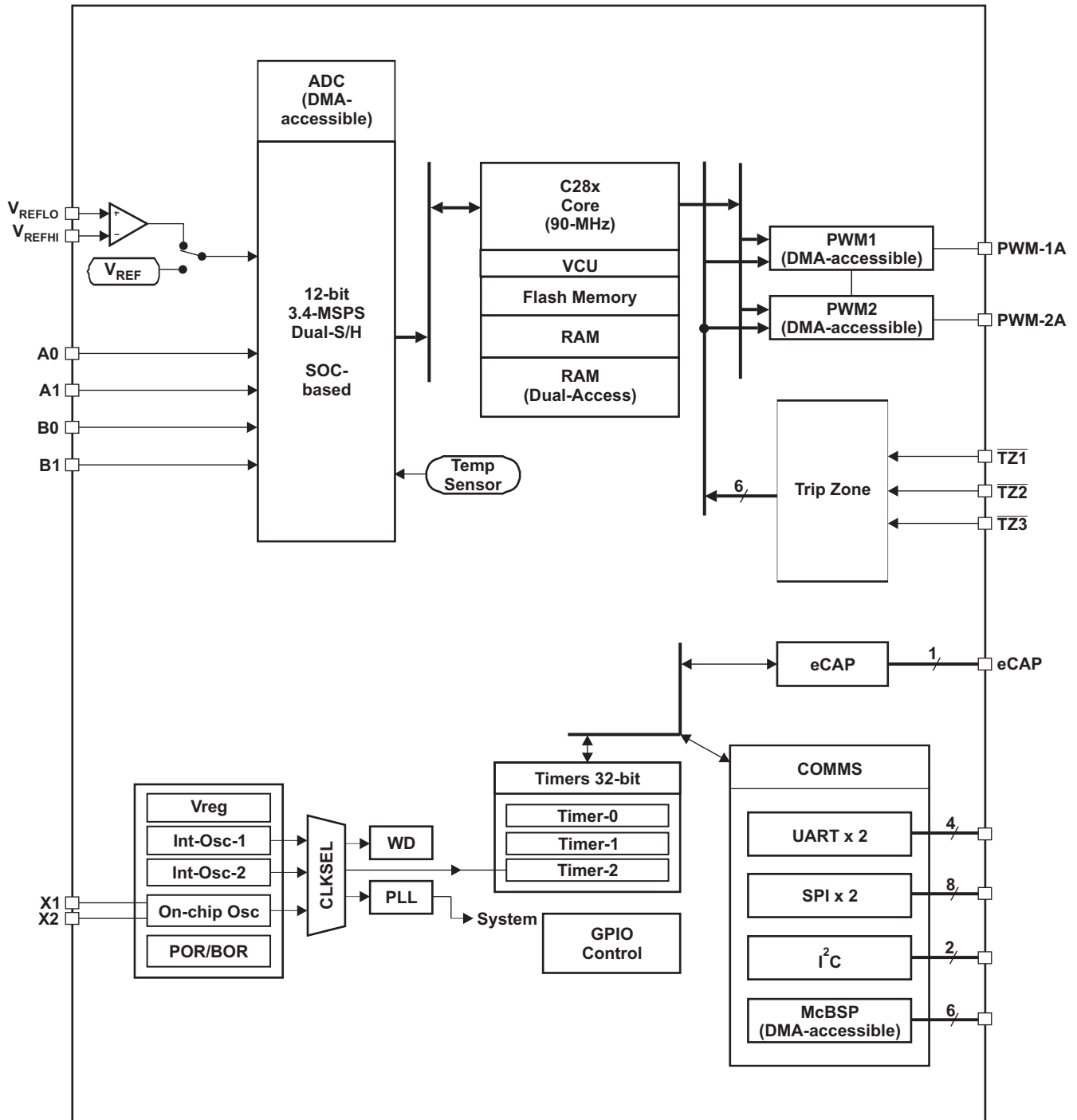

Figure 1-2. Peripheral Blocks

## Table of Contents

<b>1 Device Overview</b> ..... <a href="#">1</a>	<b>5.8 Current Consumption</b> ..... <a href="#">96</a>
1.1 Features ..... <a href="#">1</a>	5.9 Parameter Information ..... <a href="#">99</a>
1.2 Applications ..... <a href="#">1</a>	5.10 Test Load Circuit ..... <a href="#">99</a>
1.3 Description ..... <a href="#">2</a>	5.11 Flash Timing ..... <a href="#">100</a>
1.4 Functional Block Diagram ..... <a href="#">3</a>	<b>6 Detailed Description</b> ..... <a href="#">102</a>
1.5 Additional Block Diagrams ..... <a href="#">4</a>	6.1 Overview ..... <a href="#">102</a>
<b>2 Revision History</b> ..... <a href="#">6</a>	6.2 Memory ..... <a href="#">118</a>
<b>3 Device Comparison</b> ..... <a href="#">7</a>	6.3 Identification..... <a href="#">123</a>
<b>4 Terminal Configuration and Functions</b> ..... <a href="#">8</a>	<b>7 Device and Documentation Support</b> ..... <a href="#">124</a>
4.1 Signal Descriptions ..... <a href="#">9</a>	7.1 Device Support..... <a href="#">124</a>
4.2 Pin Multiplexing ..... <a href="#">15</a>	7.2 Documentation Support..... <a href="#">126</a>
<b>5 Specifications</b> ..... <a href="#">17</a>	7.3 Related Links ..... <a href="#">126</a>
5.1 Absolute Maximum Ratings ..... <a href="#">17</a>	7.4 Community Resources..... <a href="#">127</a>
5.2 Handling Ratings ..... <a href="#">17</a>	7.5 Trademarks ..... <a href="#">127</a>
5.3 Recommended Operating Conditions..... <a href="#">18</a>	7.6 Electrostatic Discharge Caution ..... <a href="#">127</a>
5.4 Electrical Characteristics ..... <a href="#">18</a>	7.7 Glossary..... <a href="#">127</a>
5.5 Thermal Resistance Characteristics for PN Package ..... <a href="#">19</a>	<b>8 Mechanical Packaging and Orderable Information</b> ..... <a href="#">128</a>
5.6 Thermal Design Considerations ..... <a href="#">19</a>	8.1 Packaging Information ..... <a href="#">128</a>
5.7 Timing and Switching Characteristics ..... <a href="#">20</a>	

## 2 Revision History

NOTE: Page numbers for previous revisions may differ from page numbers in the current version.

DATE	REVISION	NOTES
September 2014	*	Initial Release

### 3 Device Comparison

Table 3-1 lists the features of the F28PLC8x devices.

#### NOTE

The F28PLC84 device has the same hardware features as the F28PLC83 device. The only difference is that the F28PLC84 has a new ROM code with additional PLC software included.

**Table 3-1. Device Comparison**

FEATURE		TYPE <sup>(1)</sup>	F28PLC84 F28PLC83 (90 MHz)
Package Type			80-Pin PN
Instruction cycle		–	11.11 ns
VCU			Yes
6-Channel Direct Memory Access (DMA)		0	Yes
On-chip Flash (16-bit word)		–	128K
On-chip SARAM (16-bit word)		–	50K
Code security for on-chip Flash, SARAM, and One-time programmable (OTP) blocks		–	Yes
Boot ROM (32K x 16)		–	Yes
OTP ROM (16-bit word)		–	1K
Enhanced Pulse Width Modulator (ePWM) channels		1	2
High-resolution ePWM channels		1	2
Enhanced Capture (eCAP) inputs		0	1
Watchdog timer		–	Yes
12-Bit ADC	MSPS	3	3.4
	Conversion Time		289 ns
	Channels		4
	Temperature Sensor		Yes
	Dual Sample-and-Hold		Yes
32-Bit CPU timers		–	3
Comparators with Integrated DACs		0	3
I <sup>2</sup> C		0	1
McBSP		1	1
SPI		1	2
SCI		0	2
2-pin Oscillator			1
0-pin Oscillator			2
I/O pins (shared)	General-Purpose Input/Output (GPIO)	–	40
	Analog Input/Output (AIO)	–	6
External interrupts		–	3
Supply voltage (nominal)		–	3.3 V
Temperature options	T: –40°C to 105°C	–	Yes
Product status <sup>(2)</sup>		–	TMS

- (1) A type change represents a major functional feature difference in a peripheral module. Within a peripheral type, there may be minor differences between devices that do not affect the basic functionality of the module. These device-specific differences are listed in the *TMS320x28xx, 28xxx DSP Peripheral Reference Guide* ([SPRU566](#)) and in the peripheral reference guides.
- (2) See [Section 7.1.2](#), Device and Development Support Tool Nomenclature, for descriptions of device stages. The "TMS" product status denotes a fully qualified production device.

## 4 Terminal Configuration and Functions

Figure 4-1 shows the pin assignments on the 80-pin PN package.

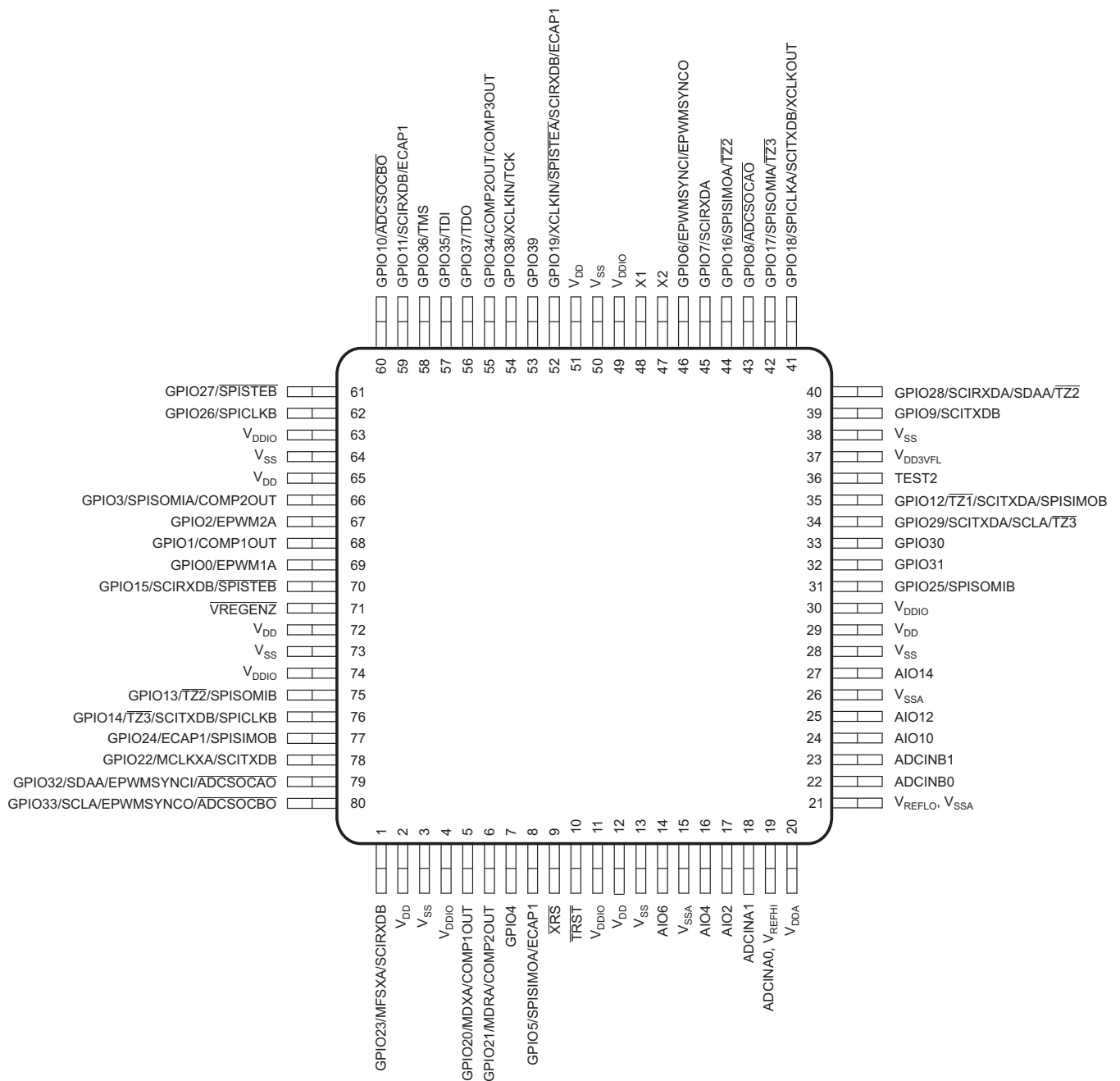

- A. Pin 19:  $V_{REFHI}$  and ADCINA0 share the same pin on the 80-pin PN device and their use is mutually exclusive to one another.  
Pin 21:  $V_{REFLO}$  is always connected to  $V_{SSA}$  on the 80-pin PN device.

**Figure 4-1. 80-Pin PN Package (Top View)**

## 4.1 Signal Descriptions

Table 4-1 describes the signals. With the exception of the JTAG pins, the GPIO function is the default at reset, unless otherwise mentioned. The peripheral signals that are listed under them are alternate functions. Inputs are not 5-V tolerant. All GPIO pins are I/O/Z and have an internal pullup, which can be selectively enabled or disabled on a per-pin basis. This feature only applies to the GPIO pins. The pullups on the PWM pins are not enabled at reset. The pullups on other GPIO pins are enabled upon reset. The AIO pins do not have an internal pullup.

**NOTE:** When the on-chip voltage regulator (VREG) is used, the GPIO19, GPIO34, GPIO35, GPIO36, GPIO37, and GPIO38 pins could glitch during power up. If this behavior is unacceptable in an application, 1.8 V could be supplied externally. There is no power-sequencing requirement when using an external 1.8-V supply. However, if the 3.3-V transistors in the level-shifting output buffers of the I/O pins are powered prior to the 1.9-V transistors, it is possible for the output buffers to turn on, causing a glitch to occur on the pin during power up. To avoid this behavior, power the  $V_{DD}$  pins prior to or simultaneously with the  $V_{DDIO}$  pins, ensuring that the  $V_{DD}$  pins have reached 0.7 V before the  $V_{DDIO}$  pins reach 0.7 V.

**Table 4-1. Signal Descriptions<sup>(1)</sup>**

TERMINAL		I/O/Z	DESCRIPTION
NAME	PN PIN NO.		
<b>JTAG</b>			
$\overline{\text{TRST}}$	10	I	JTAG test reset with internal pulldown. $\overline{\text{TRST}}$ , when driven high, gives the scan system control of the operations of the device. If this signal is not connected or driven low, the device operates in its functional mode, and the test reset signals are ignored. <b>NOTE:</b> $\overline{\text{TRST}}$ is an active-high test pin and must be maintained low at all times during normal device operation. An external pulldown resistor is required on this pin. The value of this resistor should be based on drive strength of the debugger pods applicable to the design. A 2.2-k $\Omega$ resistor generally offers adequate protection. Since the value of the resistor is application-specific, TI recommends that each target board be validated for proper operation of the debugger and the application. (↓)
TCK	See GPIO38	I	See GPIO38. JTAG test clock with internal pullup. (↑)
TMS	See GPIO36	I	See GPIO36. JTAG test-mode select (TMS) with internal pullup. This serial control input is clocked into the TAP controller on the rising edge of TCK. (↑)
TDI	See GPIO35	I	See GPIO35. JTAG test data input (TDI) with internal pullup. TDI is clocked into the selected register (instruction or data) on a rising edge of TCK. (↑)
TDO	See GPIO37	O/Z	See GPIO37. JTAG scan out, test data output (TDO). The contents of the selected register (instruction or data) are shifted out of TDO on the falling edge of TCK. (8-mA drive)
<b>FLASH</b>			
$V_{DD3VFL}$	37		3.3-V Flash Core Power Pin. This pin should be connected to 3.3 V at all times.
TEST2	36	I/O	Test Pin. Reserved for TI. Must be left unconnected.

(1) I = Input, O = Output, Z = High Impedance, OD = Open Drain, ↑ = Pullup, ↓ = Pulldown

Table 4-1. Signal Descriptions<sup>(1)</sup> (continued)

TERMINAL		I/O/Z	DESCRIPTION
NAME	PN PIN NO.		
<b>CLOCK</b>			
XCLKOUT	See GPIO18	O/Z	See GPIO18. Output clock derived from SYSCLKOUT. XCLKOUT is either the same frequency, one-half the frequency, or one-fourth the frequency of SYSCLKOUT. The value of XCLKOUT is controlled by bits 1:0 (XCLKOUTDIV) in the XCLK register. At reset, XCLKOUT = SYSCLKOUT/4. The XCLKOUT signal can be turned off by setting XCLKOUTDIV to 3. The mux control for GPIO18 must also be set to XCLKOUT for this signal to propagate to the pin.
XCLKIN	See GPIO19 and GPIO38	I	See GPIO19 and GPIO38. External oscillator input. Pin source for the clock is controlled by the XCLKINSEL bit in the XCLK register, GPIO38 is the default selection. This pin feeds a clock from an external 3.3-V oscillator. In this case, the X1 pin, if available, must be tied to GND and the on-chip crystal oscillator must be disabled via bit 14 in the CLKCTL register. If a crystal/resonator is used, the XCLKIN path must be disabled by bit 13 in the CLKCTL register. <b>NOTE:</b> Designs that use the GPIO38/XCLKIN/TCK pin to supply an external clock for normal device operation may need to incorporate some hooks to disable this path during debug using the JTAG connector. This action is to prevent contention with the TCK signal, which is active during JTAG debug sessions. The zero-pin internal oscillators may be used during this time to clock the device.
X1	48	I	On-chip crystal-oscillator input. To use this oscillator, a quartz crystal or a ceramic resonator must be connected across X1 and X2. In this case, the XCLKIN path must be disabled by bit 13 in the CLKCTL register. If this pin is not used, this pin must be tied to GND.
X2	47	O	On-chip crystal-oscillator output. A quartz crystal or a ceramic resonator must be connected across X1 and X2. If X2 is not used, X2 must be left unconnected.
<b>RESET</b>			
$\overline{\text{XRS}}$	9	I/OD	Device Reset (in) and Watchdog Reset (out). The F28PLC8x device has a built-in power-on reset (POR) and brown-out reset (BOR) circuitry. During a power-on or brown-out condition, this pin is driven low by the device. An external circuit may also drive this pin to assert a device reset. This pin is also driven low by the device when a watchdog reset occurs. During watchdog reset, the $\overline{\text{XRS}}$ pin is driven low for the watchdog reset duration of 512 OSCCLK cycles. A resistor between 2.2 k $\Omega$ and 10 k $\Omega$ should be placed between $\overline{\text{XRS}}$ and $V_{\text{DDIO}}$ . If a capacitor is placed between $\overline{\text{XRS}}$ and $V_{\text{SS}}$ for noise filtering, it should be 100 nF or smaller. These values will allow the watchdog to properly drive the $\overline{\text{XRS}}$ pin to $V_{\text{OL}}$ within 512 OSCCLK cycles when the watchdog reset is asserted. Regardless of the source, a device reset causes the device to terminate execution. The program counter points to the address contained at the location 0x3F FFC0. When reset is deactivated, execution begins at the location designated by the program counter. The output buffer of this pin is an open-drain with an internal pullup. (†)

**Table 4-1. Signal Descriptions<sup>(1)</sup> (continued)**

TERMINAL		I/O/Z	DESCRIPTION
NAME	PN PIN NO.		
<b>ADC, COMPARATOR, ANALOG I/O</b>			
AIO6	14	I/O	Digital AIO 6
AIO4	16	I/O	Digital AIO 4
AIO2	17	I/O	Digital AIO 2
ADCINA1	18	I	ADC Group A, Channel 1 input
ADCINA0	19	I	ADC Group A, Channel 0 input. <b>NOTE:</b> $V_{REFHI}$ and ADCINA0 share the same pin on the 80-pin PN device and their use is mutually exclusive to one another.
$V_{REFHI}$	19		ADC External Reference – only used when in ADC external reference mode. See <a href="#">Section 5.7.4.1.1</a> . <b>NOTE:</b> $V_{REFHI}$ and ADCINA0 share the same pin on the 80-pin PN device and their use is mutually exclusive to one another.
AIO14	27	I/O	Digital AIO 14
AIO12	25	I/O	Digital AIO12
AIO10	24	I/O	Digital AIO 10
ADCINB1	23	I	ADC Group B, Channel 1 input
ADCINB0	22	I	ADC Group B, Channel 0 input
$V_{REFLO}$	21		<b>NOTE:</b> $V_{REFLO}$ is always connected to $V_{SSA}$ on the 80-pin PN device.
<b>CPU AND I/O POWER</b>			
$V_{DDA}$	20		Analog Power Pin. Tie with a 2.2- $\mu$ F capacitor (typical) close to the pin.
$V_{SSA}$	15		Analog Ground Pin. <b>NOTE:</b> $V_{REFLO}$ is always connected to $V_{SSA}$ on the 80-pin PN device.
$V_{SSA}$	21		
$V_{SSA}$	26		
$V_{DD}$	2		CPU and Logic Digital Power Pins. When using internal VREG, place one 1.2- $\mu$ F capacitor between each $V_{DD}$ pin and ground. Higher value capacitors may be used.
$V_{DD}$	12		
$V_{DD}$	29		
$V_{DD}$	51		
$V_{DD}$	65		
$V_{DD}$	72		
$V_{DDIO}$	4		Digital I/O and Flash Power Pin – Single Supply source when VREG is enabled.
$V_{DDIO}$	11		
$V_{DDIO}$	30		
$V_{DDIO}$	49		
$V_{DDIO}$	63		
$V_{DDIO}$	74		
$V_{SS}$	3		Digital Ground Pins
$V_{SS}$	13		
$V_{SS}$	28		
$V_{SS}$	38		
$V_{SS}$	50		
$V_{SS}$	64		
$V_{SS}$	73		
<b>VOLTAGE REGULATOR CONTROL SIGNAL</b>			
$V_{REGENZ}$	71	I	Internal VREG Enable/Disable – pull low to enable VREG, pull high to disable VREG.

Table 4-1. Signal Descriptions<sup>(1)</sup> (continued)

TERMINAL		I/O/Z	DESCRIPTION
NAME	PN PIN NO.		
<b>GPIO AND PERIPHERAL SIGNALS <sup>(1)</sup></b>			
<b>GPIO0</b> EPWM1A	69	I/O/Z O	General-purpose input/output 0 Enhanced PWM1 Output A and High-resolution Pulse Width Modulator (HRPWM) channel
<b>GPIO1</b> COMP1OUT	68	I/O/Z O	General-purpose input/output 1 Direct output of Comparator 1
<b>GPIO2</b> EPWM2A	67	I/O/Z O	General-purpose input/output 2 Enhanced PWM2 Output A and HRPWM channel
<b>GPIO3</b> SPISOMIA COMP2OUT	66	I/O/Z I/O O	General-purpose input/output 3 SPI-A slave out, master in Direct output of Comparator 2
<b>GPIO4</b>	7	I/O/Z	General-purpose input/output 4
<b>GPIO5</b> SPISIMOA ECAP1	8	I/O/Z I/O I/O	General-purpose input/output 5 SPI-A slave in, master out Enhanced Capture input/output 1
<b>GPIO6</b> EPWMSYNCI EPWMSYNCO	46	I/O/Z I O	General-purpose input/output 6 External ePWM sync pulse input External ePWM sync pulse output
<b>GPIO7</b> SCIRXDA	45	I/O/Z I	General-purpose input/output 7 SCI-A receive data
<b>GPIO8</b> Reserved $\overline{\text{ADCSOCAO}}$	43	I/O/Z – O	General-purpose input/output 8 Reserved ADC start-of-conversion A
<b>GPIO9</b> SCITXDB	39	I/O/Z O	General-purpose input/output 9 SCI-B transmit data
<b>GPIO10</b> Reserved $\overline{\text{ADCSOCBO}}$	60	I/O/Z – O	General-purpose input/output 10 Reserved ADC start-of-conversion B
<b>GPIO11</b> SCIRXDB ECAP1	59	I/O/Z I I/O	General-purpose input/output 11 SCI-B receive data Enhanced Capture input/output 1
<b>GPIO12</b> $\overline{\text{TZ1}}$ SCITXDA SPISIMOB	35	I/O/Z I O I/O	General-purpose input/output 12 Trip Zone input 1 SCI-A transmit data SPI-B slave in, master out
<b>GPIO13</b> $\overline{\text{TZ2}}$ Reserved SPISOMIB	75	I/O/Z I – I/O	General-purpose input/output 13 Trip Zone input 2 Reserved SPI-B slave out, master in
<b>GPIO14</b> $\overline{\text{TZ3}}$ SCITXDB SPICLKB	76	I/O/Z I O I/O	General-purpose input/output 14 Trip zone input 3 SCI-B transmit data SPI-B clock input/output

(1) The GPIO function (shown in bold italics) is the default at reset. The peripheral signals that are listed under them are alternate functions. For JTAG pins that have the GPIO functionality multiplexed, the input path to the GPIO block is always valid. The output path from the GPIO block and the path to the JTAG block from a pin is enabled or disabled based on the condition of the TRST signal.

**Table 4-1. Signal Descriptions<sup>(1)</sup> (continued)**

TERMINAL		I/O/Z	DESCRIPTION
NAME	PN PIN NO.		
<b>GPIO15</b> SCIRXDB $\overline{\text{SPISTEB}}$	70	I/O/Z I I/O	General-purpose input/output 15 SCI-B receive data SPI-B slave transmit enable input/output
<b>GPIO16</b> SPISIMOA Reserved $\overline{\text{TZ2}}$	44	I/O/Z I/O – I	General-purpose input/output 16 SPI-A slave in, master out Reserved Trip Zone input 2
<b>GPIO17</b> SPISOMIA Reserved $\overline{\text{TZ3}}$	42	I/O/Z I/O – I	General-purpose input/output 17 SPI-A slave out, master in Reserved Trip zone input 3
<b>GPIO18</b> SPICLKA SCITXDB XCLKOUT	41	I/O/Z I/O O O/Z	General-purpose input/output 18 SPI-A clock input/output SCI-B transmit data Output clock derived from SYSCLKOUT. XCLKOUT is either the same frequency, one-half the frequency, or one-fourth the frequency of SYSCLKOUT. The value of XCLKOUT is controlled by bits 1:0 (XCLKOUTDIV) in the XCLK register. At reset, XCLKOUT = SYSCLKOUT/4. The XCLKOUT signal can be turned off by setting XCLKOUTDIV to 3. The mux control for GPIO18 must also be set to XCLKOUT for this signal to propagate to the pin.
<b>GPIO19</b> XCLKIN  $\overline{\text{SPISTEA}}$ SCIRXDB ECAP1	52	I/O/Z I I/O I I/O	General-purpose input/output 19 External Oscillator Input. The path from this pin to the clock block is not gated by the mux function of this pin. Care must be taken not to enable this path for clocking if this path is being used for the other peripheral functions. SPI-A slave transmit enable input/output SCI-B receive data Enhanced Capture input/output 1
<b>GPIO20</b> MDXA COMP1OUT	5	I/O/Z O O	General-purpose input/output 20 McBSP transmit serial data Direct output of Comparator 1
<b>GPIO21</b> MDRA COMP2OUT	6	I/O/Z I O	General-purpose input/output 21 McBSP receive serial data Direct output of Comparator 2
<b>GPIO22</b> MCLKXA SCITXDB	78	I/O/Z I/O O	General-purpose input/output 22 McBSP transmit clock SCI-B transmit data
<b>GPIO23</b> MFSXA SCIRXDB	1	I/O/Z I/O I	General-purpose input/output 23 McBSP transmit frame synch SCI-B receive data
<b>GPIO24</b> ECAP1 SPISIMOB	77	I/O/Z I/O I/O	General-purpose input/output 24 Enhanced Capture input/output 1 SPI-B slave in, master out
<b>GPIO25</b> SPISOMIB	31	I/O/Z I/O	General-purpose input/output 25 SPI-B slave out, master in

Table 4-1. Signal Descriptions<sup>(1)</sup> (continued)

TERMINAL		I/O/Z	DESCRIPTION
NAME	PN PIN NO.		
<b>GPIO26</b> SPICLK	62	I/O/Z I/O	General-purpose input/output 26 SPI-B clock input/output
<b>GPIO27</b> $\overline{\text{SPISTEB}}$	61	I/O/Z I/O	General-purpose input/output 27 SPI-B slave transmit enable input/output
<b>GPIO28</b> SCIRXDA SDAA $\overline{\text{TZ2}}$	40	I/O/Z I I/OD I	General-purpose input/output 28 SCI-A receive data I <sup>2</sup> C data open-drain bidirectional port Trip zone input 2
<b>GPIO29</b> SCITXDA SCLA $\overline{\text{TZ3}}$	34	I/O/Z O I/OD I	General-purpose input/output 29 SCI-A transmit data I <sup>2</sup> C clock open-drain bidirectional port Trip zone input 3
<b>GPIO30</b>	33	I/O/Z	General-purpose input/output 30
<b>GPIO31</b>	32	I/O/Z	General-purpose input/output 31
<b>GPIO32</b> SDAA EPWMSYNCl $\overline{\text{ADCSOCAO}}$	79	I/O/Z I/OD I O	General-purpose input/output 32 I <sup>2</sup> C data open-drain bidirectional port Enhanced PWM external sync pulse input ADC start-of-conversion A
<b>GPIO33</b> SCLA EPWMSYNCO $\overline{\text{ADCSOCBO}}$	80	I/O/Z I/OD O O	General-purpose input/output 33 I <sup>2</sup> C clock open-drain bidirectional port Enhanced PWM external synch pulse output ADC start-of-conversion B
<b>GPIO34</b> COMP2OUT COMP3OUT	55	I/O/Z O O	General-purpose input/output 34 Direct output of Comparator 2 Direct output of Comparator 3
GPIO35 TDI	57	I/O/Z I	General-purpose input/output 35 JTAG test data input with internal pullup. TDI is clocked into the selected register (instruction or data) on a rising edge of TCK.
GPIO36 TMS	58	I/O/Z I	General-purpose input/output 36 JTAG test-mode select with internal pullup. This serial control input is clocked into the TAP controller on the rising edge of TCK.
GPIO37 TDO	56	I/O/Z O/Z	General-purpose input/output 37 JTAG scan out, test data output. The contents of the selected register (instruction or data) are shifted out of TDO on the falling edge of TCK (8 mA drive).
GPIO38 XCLKIN  TCK	54	I/O/Z I  I	General-purpose input/output 38 External Oscillator Input. The path from this pin to the clock block is not gated by the mux function of this pin. Care must be taken to not enable this path for clocking if this path is being used for the other functions. JTAG test clock with internal pullup
GPIO39	53	I/O/Z	General-purpose input/output 39

## 4.2 Pin Multiplexing

Table 4-2. GPIOA MUX<sup>(1) (2)</sup>

	DEFAULT AT RESET PRIMARY I/O FUNCTION	PERIPHERAL SELECTION 1	PERIPHERAL SELECTION 2	PERIPHERAL SELECTION 3
<b>GPAMUX1 REGISTER BITS</b>	<b>(GPAMUX1 BITS = 00)</b>	<b>(GPAMUX1 BITS = 01)</b>	<b>(GPAMUX1 BITS = 10)</b>	<b>(GPAMUX1 BITS = 11)</b>
1-0	GPIO0	EPWM1A (O)	Reserved	Reserved
3-2	GPIO1	Reserved	Reserved	COMP1OUT (O)
5-4	GPIO2	EPWM2A (O)	Reserved	Reserved
7-6	GPIO3	Reserved	SPISOMIA (I/O)	COMP2OUT (O)
9-8	GPIO4	Reserved	Reserved	Reserved
11-10	GPIO5	Reserved	SPISIMOA (I/O)	ECAP1 (I/O)
13-12	GPIO6	Reserved	EPWMSYNCl (I)	EPWMSYNCO (O)
15-14	GPIO7	Reserved	SCIRXDA (I)	Reserved
17-16	GPIO8	Reserved	Reserved	ADCSOCAO (O)
19-18	GPIO9	Reserved	SCITXDB (O)	Reserved
21-20	GPIO10	Reserved	Reserved	ADCSOCBO (O)
23-22	GPIO11	Reserved	SCIRXDB (I)	ECAP1 (I/O)
25-24	GPIO12	TZ1 (I)	SCITXDA (O)	SPISIMOB (I/O)
27-26	GPIO13	TZ2 (I)	Reserved	SPISOMIB (I/O)
29-28	GPIO14	TZ3 (I)	SCITXDB (O)	SPICLKB (I/O)
31-30	GPIO15	Reserved	SCIRXDB (I)	SPISTEB (I/O)
<b>GPAMUX2 REGISTER BITS</b>	<b>(GPAMUX2 BITS = 00)</b>	<b>(GPAMUX2 BITS = 01)</b>	<b>(GPAMUX2 BITS = 10)</b>	<b>(GPAMUX2 BITS = 11)</b>
1-0	GPIO16	SPISIMOA (I/O)	Reserved	TZ2 (I)
3-2	GPIO17	SPISOMIA (I/O)	Reserved	TZ3 (I)
5-4	GPIO18	SPICLKA (I/O)	SCITXDB (O)	XCLKOUT (O)
7-6	GPIO19/XCLKIN	SPISTEA (I/O)	SCIRXDB (I)	ECAP1 (I/O)
9-8	GPIO20	Reserved	MDXA (O)	COMP1OUT (O)
11-10	GPIO21	Reserved	MDRA (I)	COMP2OUT (O)
13-12	GPIO22	Reserved	MCLKXA (I/O)	SCITXDB (O)
15-14	GPIO23	Reserved	MFSXA (I/O)	SCIRXDB (I)
17-16	GPIO24	ECAP1 (I/O)	Reserved	SPISIMOB (I/O)
19-18	GPIO25	Reserved	Reserved	SPISOMIB (I/O)
21-20	GPIO26	Reserved	Reserved	SPICLKB (I/O)
23-22	GPIO27	Reserved	Reserved	SPISTEB (I/O)
25-24	GPIO28	SCIRXDA (I)	SDAA (I/OD)	TZ2 (I)
27-26	GPIO29	SCITXDA (O)	SCLA (I/OD)	TZ3 (I)
29-28	GPIO30	Reserved	Reserved	Reserved
31-30	GPIO31	Reserved	Reserved	Reserved

(1) The word "Reserved" means that there is no peripheral assigned to this GPxMUX1/2 register setting. Should the Reserved GPxMUX1/2 register setting be selected, the state of the pin will be undefined and the pin may be driven. This selection is a reserved configuration for future expansion.

(2) I = Input, O = Output, OD = Open Drain

**Table 4-3. GPIOB MUX<sup>(1)(2)</sup>**

	DEFAULT AT RESET PRIMARY I/O FUNCTION	PERIPHERAL SELECTION 1	PERIPHERAL SELECTION 2	PERIPHERAL SELECTION 3
GPBMUX1 REGISTER BITS	(GPBMUX1 BITS = 00)	(GPBMUX1 BITS = 01)	(GPBMUX1 BITS = 10)	(GPBMUX1 BITS = 11)
1-0	GPIO32	SDAA (I/OD)	EPWMSYNCl (I)	ADCSOCAO (O)
3-2	GPIO33	SCLA (I/OD)	EPWMSYNCO (O)	ADCSOCBO (O)
5-4	GPIO34	COMP2OUT (O)	Reserved	COMP3OUT (O)
7-6	GPIO35 (TDI)	Reserved	Reserved	Reserved
9-8	GPIO36 (TMS)	Reserved	Reserved	Reserved
11-10	GPIO37 (TDO)	Reserved	Reserved	Reserved
13-12	GPIO38/XCLKIN (TCK)	Reserved	Reserved	Reserved
15-14	GPIO39	Reserved	Reserved	Reserved
17-16	Reserved	Reserved	Reserved	Reserved
19-18	Reserved	Reserved	Reserved	Reserved
21-20	Reserved	Reserved	Reserved	Reserved
23-22	Reserved	Reserved	Reserved	Reserved
25-24	Reserved	Reserved	Reserved	Reserved
27-26	Reserved	Reserved	Reserved	Reserved
29-28	Reserved	Reserved	Reserved	Reserved
31-30	Reserved	Reserved	Reserved	Reserved

(1) The word "Reserved" means that there is no peripheral assigned to this GPxMUX1/2 register setting. Should the Reserved GPxMUX1/2 register setting be selected, the state of the pin will be undefined and the pin may be driven. This selection is a reserved configuration for future expansion.

(2) I = Input, O = Output, OD = Open Drain

**Table 4-4. Analog MUX<sup>(1)</sup>**

		DEFAULT AT RESET
	AIOx AND PERIPHERAL SELECTION 1	PERIPHERAL SELECTION 2 AND PERIPHERAL SELECTION 3
AIOMUX1 REGISTER BITS	AIOMUX1 BITS = 0,x	AIOMUX1 BITS = 1,x
1-0	ADCINA0 (I)	ADCINA0 (I)
3-2	ADCINA1 (I)	ADCINA1 (I)
5-4	AIO2 (I/O)	Reserved
7-6	Reserved	Reserved
9-8	AIO4 (I/O)	Reserved
11-10	Reserved	Reserved
13-12	AIO6 (I/O)	Reserved
15-14	Reserved	Reserved
17-16	ADCINB0 (I)	ADCINB0 (I)
19-18	ADCINB1 (I)	ADCINB1 (I)
21-20	AIO10 (I/O)	Reserved
23-22	Reserved	Reserved
25-24	AIO12 (I/O)	Reserved
27-26	Reserved	Reserved
29-28	AIO14 (I/O)	Reserved
31-30	Reserved	Reserved

(1) I = Input, O = Output

## 5 Specifications

### 5.1 Absolute Maximum Ratings<sup>(1) (2)</sup>

Supply voltage range, $V_{DDIO}$ (I/O and Flash)	with respect to $V_{SS}$	-0.3 V to 4.6 V
Supply voltage range, $V_{DD}$	with respect to $V_{SS}$	-0.3 V to 2.5 V
Analog voltage range, $V_{DDA}$	with respect to $V_{SSA}$	-0.3 V to 4.6 V
Input voltage range, $V_{IN}$ (3.3 V)		-0.3 V to 4.6 V
Output voltage range, $V_O$		-0.3 V to 4.6 V
Input clamp current, $I_{IK}$ ( $V_{IN} < 0$ or $V_{IN} > V_{DDIO}$ ) <sup>(3)</sup>		$\pm 20$ mA
Output clamp current, $I_{OK}$ ( $V_O < 0$ or $V_O > V_{DDIO}$ )		$\pm 20$ mA
Junction temperature range, $T_J$ <sup>(4)</sup>		-40°C to 125°C

- (1) Stresses beyond those listed under Absolute Maximum Ratings may cause permanent damage to the device. These are stress ratings only, and functional operation of the device at these or any other conditions beyond those indicated under [Section 5.3](#) is not implied. Exposure to absolute-maximum-rated conditions for extended periods may affect device reliability.
- (2) All voltage values are with respect to  $V_{SS}$ , unless otherwise noted.
- (3) Continuous clamp current per pin is  $\pm 2$  mA.
- (4) Long-term high-temperature storage or extended use at maximum temperature conditions may result in a reduction of overall device life. For additional information, see the *IC Package Thermal Metrics Application Report* ([SPRA953](#)).

### 5.2 Handling Ratings

			MIN	MAX	UNIT
$T_{stg}$	Storage temperature range <sup>(1)</sup>		-65	150	°C
$V_{ESD}$	Electrostatic discharge (ESD) <sup>(2)</sup> performance	Human Body Model (HBM), per ANSI/ESDA/JEDEC JS-001 <sup>(3)</sup>	-2	2	kV
		Charged Device Model (CDM), per JESD22-C101 <sup>(4)</sup>	-500	500	V
		All pins			

- (1) Long-term high-temperature storage or extended use at maximum temperature conditions may result in a reduction of overall device life. For additional information, see the *IC Package Thermal Metrics Application Report* ([SPRA953](#)).
- (2) ESD measures device sensitivity/immunity to damage caused by assembly line electrostatic discharges into the device.
- (3) JEDEC publication JEP155 states that 500-V HBM allows safe manufacturing with a standard ESD control process.
- (4) JEDEC publication JEP157 states that 250-V CDM allows safe manufacturing with a standard ESD control process.

### 5.3 Recommended Operating Conditions

		MIN	NOM	MAX	UNIT
Device supply voltage, I/O, $V_{DDIO}^{(1)}$		2.97	3.3	3.63	V
Device supply voltage CPU, $V_{DD}$ (When internal VREG is disabled and 1.8 V is supplied externally)		1.71	1.8	1.995	V
Supply ground, $V_{SS}$			0		V
Analog supply voltage, $V_{DDA}^{(1)}$		2.97	3.3	3.63	V
Analog ground, $V_{SSA}$			0		V
Device clock frequency (system clock)		2		90	MHz
High-level input voltage, $V_{IH}$ (3.3 V)		2		$V_{DDIO} + 0.3$	V
Low-level input voltage, $V_{IL}$ (3.3 V)		$V_{SS} - 0.3$		0.8	V
High-level output source current, $V_{OH} = V_{OH(MIN)}$ , $I_{OH}$	All GPIO/AIO pins			-4	mA
	Group 2 <sup>(2)</sup>			-8	mA
Low-level output sink current, $V_{OL} = V_{OL(MAX)}$ , $I_{OL}$	All GPIO/AIO pins			4	mA
	Group 2 <sup>(2)</sup>			8	mA
Junction temperature, $T_J$	T version	-40		105	°C

(1)  $V_{DDIO}$  and  $V_{DDA}$  should be maintained within approximately 0.3 V of each other.

(2) Group 2 pins are as follows: GPIO16, GPIO17, GPIO18, GPIO19, GPIO28, GPIO29, GPIO36, GPIO37.

### 5.4 Electrical Characteristics<sup>(1)</sup>

over recommended operating conditions (unless otherwise noted)

PARAMETER		TEST CONDITIONS		MIN	TYP	MAX	UNIT	
$V_{OH}$	High-level output voltage	$I_{OH} = I_{OH\ MAX}$		2.4			V	
		$I_{OH} = 50\ \mu A$		$V_{DDIO} - 0.2$				
$V_{OL}$	Low-level output voltage	$I_{OL} = I_{OL\ MAX}$		0.4			V	
$I_{IL}$	Input current (low level)	Pin with pullup enabled	$V_{DDIO} = 3.3\ V, V_{IN} = 0\ V$	All GPIO	-80	-140	-205	$\mu A$
				$\overline{XRS}$ pin	-230	-300	-375	
$I_{IH}$	Input current (high level)	Pin with pulldown enabled	$V_{DDIO} = 3.3\ V, V_{IN} = 0\ V$	$\pm 2$			$\mu A$	
		Pin with pullup enabled	$V_{DDIO} = 3.3\ V, V_{IN} = V_{DDIO}$	$\pm 2$				
$I_{OH}$	Output current, pullup or pulldown disabled	Pin with pullup enabled	$V_{DDIO} = 3.3\ V, V_{IN} = V_{DDIO}$	$\pm 2$			$\mu A$	
		Pin with pulldown enabled	$V_{DDIO} = 3.3\ V, V_{IN} = V_{DDIO}$	28	50	80		
$I_{OZ}$	Output current, pullup or pulldown disabled	$V_O = V_{DDIO}$ or 0 V		$\pm 2$			$\mu A$	
$C_I$	Input capacitance			2			pF	
	$V_{DDIO}$ BOR trip point	Falling $V_{DDIO}$		2.50	2.78	2.96	V	
	$V_{DDIO}$ BOR hysteresis			35			mV	
	Supervisor reset release delay time	Time after BOR/POR/OVR event is removed to $\overline{XRS}$ release		400		800	$\mu s$	
	VREG $V_{DD}$ output	Internal VREG on		1.9			V	

(1) When the on-chip VREG is used, its output is monitored by the POR/BOR circuit, which will reset the device should the core voltage ( $V_{DD}$ ) go out of range.

## 5.5 Thermal Resistance Characteristics for PN Package

		°C/W <sup>(1)</sup>	AIR FLOW (lfm) <sup>(2)</sup>
R $\theta_{JC}$	Junction-to-case thermal resistance	7.9	0
R $\theta_{JB}$	Junction-to-board thermal resistance	15.6	0
R $\theta_{JA}$ (High k PCB)	Junction-to-free air thermal resistance	41.1	0
		31.2	150
		29.7	250
		27.5	500
Psi $_{JT}$	Junction-to-package top	0.4	0
		0.6	150
		0.7	250
		0.9	500
Psi $_{JB}$	Junction-to-board	15.3	0
		14.6	150
		14.4	250
		14.1	500

(1) These values are based on a JEDEC defined 2S2P system (with the exception of the Theta JC [R $\theta_{JC}$ ] value, which is based on a JEDEC defined 1S0P system) and will change based on environment as well as application. For more information, see these EIA/JEDEC standards:

- JESD51-2, *Integrated Circuits Thermal Test Method Environmental Conditions - Natural Convection (Still Air)*
- JESD51-3, *Low Effective Thermal Conductivity Test Board for Leaded Surface Mount Packages*
- JESD51-7, *High Effective Thermal Conductivity Test Board for Leaded Surface Mount Packages*
- JESD51-9, *Test Boards for Area Array Surface Mount Package Thermal Measurements*

(2) lfm = linear feet per minute

## 5.6 Thermal Design Considerations

Based on the end application design and operational profile, the I $_{DD}$  and I $_{DDIO}$  currents could vary. Systems that exceed the recommended maximum power dissipation in the end product may require additional thermal enhancements. Ambient temperature (T $_A$ ) varies with the end application and product design. The critical factor that affects reliability and functionality is T $_J$ , the junction temperature, not the ambient temperature. Hence, care should be taken to keep T $_J$  within the specified limits. T $_{case}$  should be measured to estimate the operating junction temperature T $_J$ . T $_{case}$  is normally measured at the center of the package top-side surface. The thermal application report *IC Package Thermal Metrics* ([SPRA953](#)) helps to understand the thermal metrics and definitions.

## 5.7 Timing and Switching Characteristics

### 5.7.1 Power Supply Sequencing

There is no power sequencing requirement needed to ensure the device is in the proper state after reset or to prevent the I/Os from glitching during power up/down (GPIO19, GPIO26–27, GPIO34–38 do not have glitch-free I/Os). No voltage larger than a diode drop (0.7 V) above  $V_{DDIO}$  should be applied to any digital pin (for analog pins, this value is 0.7 V above  $V_{DDA}$ ) prior to powering up the device. Voltages applied to pins on an unpowered device can bias internal p-n junctions in unintended ways and produce unpredictable results.

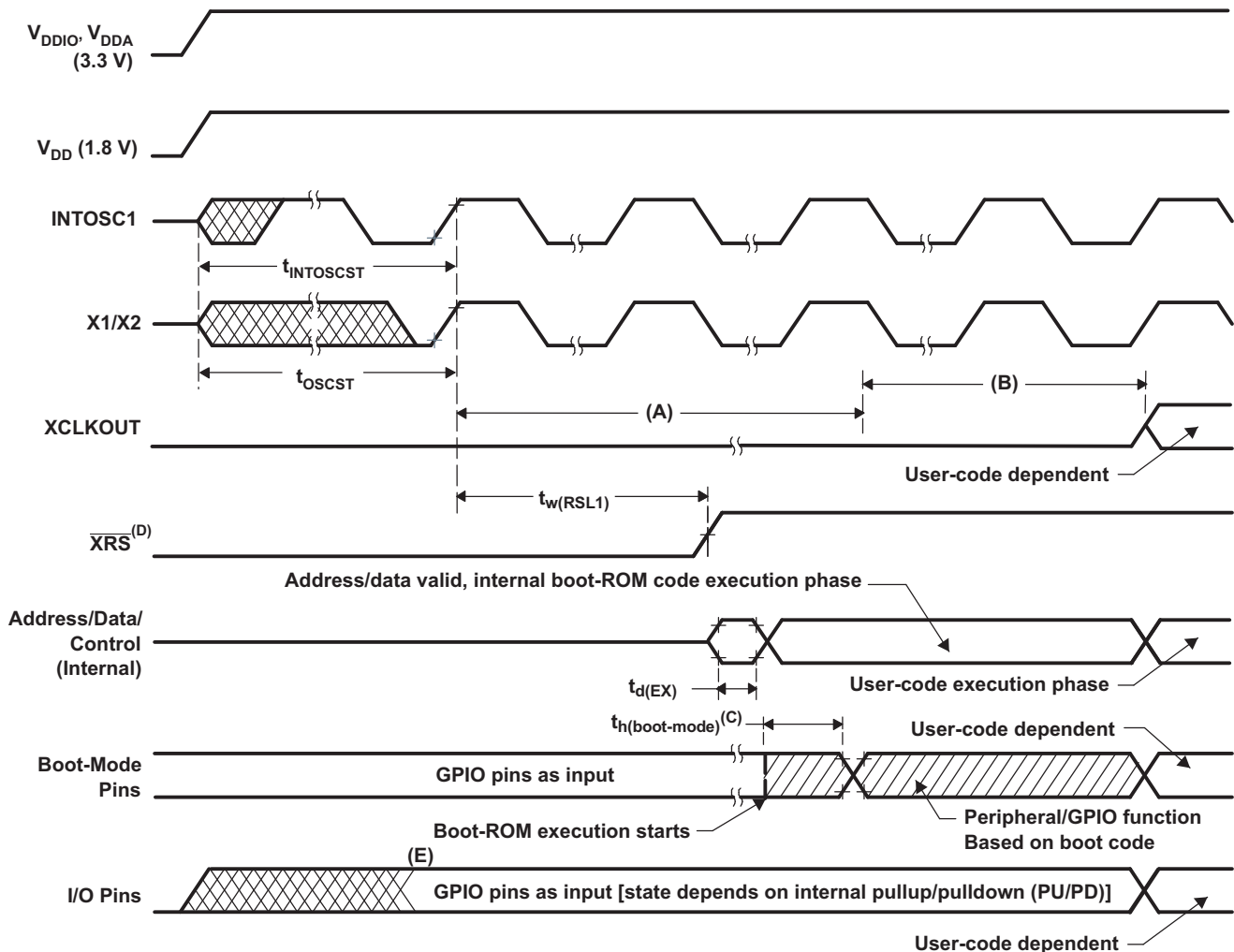

- A. Upon power up, SYSCCLKOUT is OSCCLK/4. Since the XCLKOUTDIV bits in the XCLK register come up with a reset state of 0, SYSCCLKOUT is further divided by 4 before SYSCCLKOUT appears at XCLKOUT.  $XCLKOUT = OSCCLK/16$  during this phase.
- B. Boot ROM configures the DIVSEL bits for /1 operation.  $XCLKOUT = OSCCLK/4$  during this phase. Note that XCLKOUT will not be visible at the pin until explicitly configured by user code.
- C. After reset, the boot ROM code samples Boot Mode pins. Based on the status of the Boot Mode pin, the boot code branches to destination memory or boot code function. If boot ROM code executes after power-on conditions (in debugger environment), the boot code execution time is based on the current SYSCCLKOUT speed. The SYSCCLKOUT will be based on user environment and could be with or without PLL enabled.
- D. Using the  $\overline{XRS}$  pin is optional due to the on-chip power-on reset circuitry.
- E. The internal pullup/pulldown will take effect when BOR is driven high.

Figure 5-1. Power-on Reset

### 5.7.2 Reset Timing

**Table 5-1. Reset ( $\overline{\text{XRS}}$ ) Timing Requirements**

		MIN	MAX	UNIT
$t_{h(\text{boot-mode})}$	Hold time for boot-mode pins	1000	$t_{c(\text{SCO})}$	cycles
$t_{w(\text{RSL2})}$	Pulse duration, $\overline{\text{XRS}}$ low on warm reset	32	$t_{c(\text{OSCCLK})}$	cycles

**Table 5-2. Reset ( $\overline{\text{XRS}}$ ) Switching Characteristics**

over recommended operating conditions (unless otherwise noted)

PARAMETER		MIN	TYP	MAX	UNIT
$t_{w(\text{RSL1})}$	Pulse duration, $\overline{\text{XRS}}$ driven by device		600		$\mu\text{s}$
$t_{w(\text{WDRS})}$	Pulse duration, reset pulse generated by watchdog		512	$t_{c(\text{OSCCLK})}$	cycles
$t_{d(\text{EX})}$	Delay time, address/data valid after $\overline{\text{XRS}}$ high		32	$t_{c(\text{OSCCLK})}$	cycles
$t_{\text{INTOSCST}}$	Start up time, internal zero-pin oscillator		3		$\mu\text{s}$
$t_{\text{OSCST}}^{(1)}$	On-chip crystal-oscillator start-up time	1	10		ms

(1) Dependent on crystal/resonator and board design.

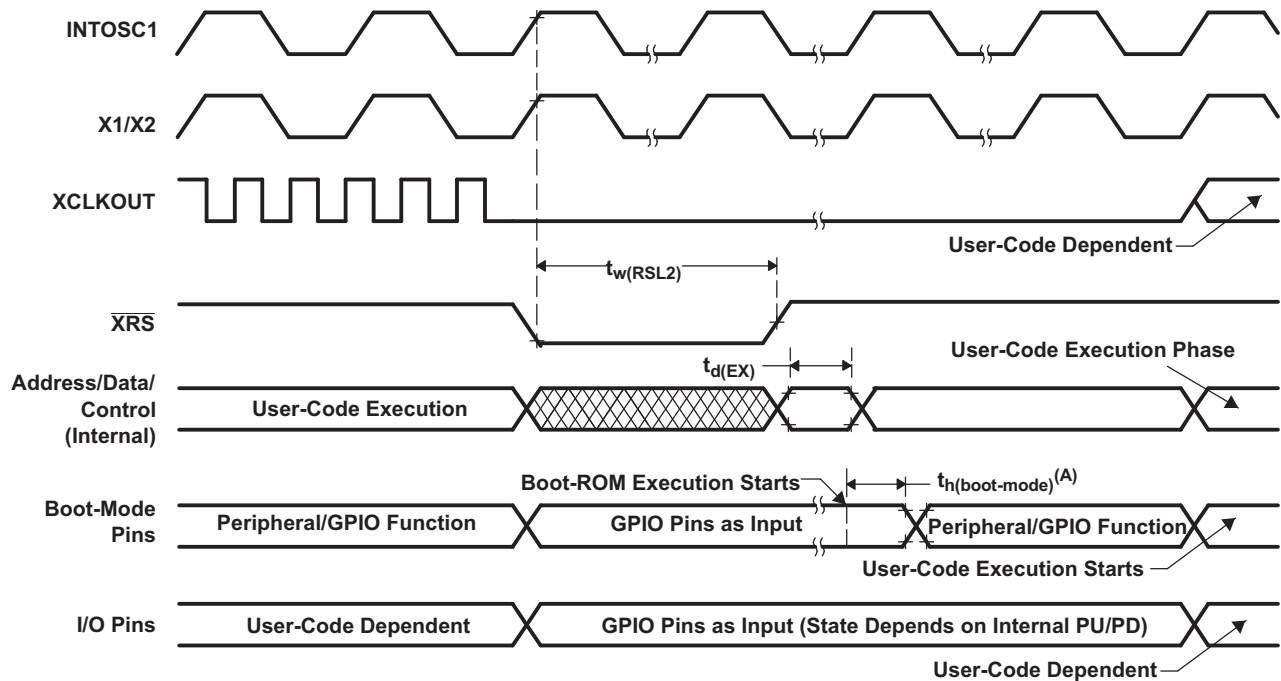

- A. After reset, the Boot ROM code samples BOOT Mode pins. Based on the status of the Boot Mode pin, the boot code branches to destination memory or boot code function. If Boot ROM code executes after power-on conditions (in debugger environment), the Boot code execution time is based on the current SYSCLKOUT speed. The SYSCLKOUT will be based on user environment and could be with or without PLL enabled.

**Figure 5-2. Warm Reset**

Figure 5-3 shows an example for the effect of writing into PLLCR register. In the first phase, PLLCR = 0x0004 and SYSCLKOUT = OSCCLK x 2. The PLLCR is then written with 0x0008. Right after the PLLCR register is written, the PLL lock-up phase begins. During this phase, SYSCLKOUT = OSCCLK/2. After the PLL lock-up is complete, SYSCLKOUT reflects the new operating frequency, OSCCLK x 4.

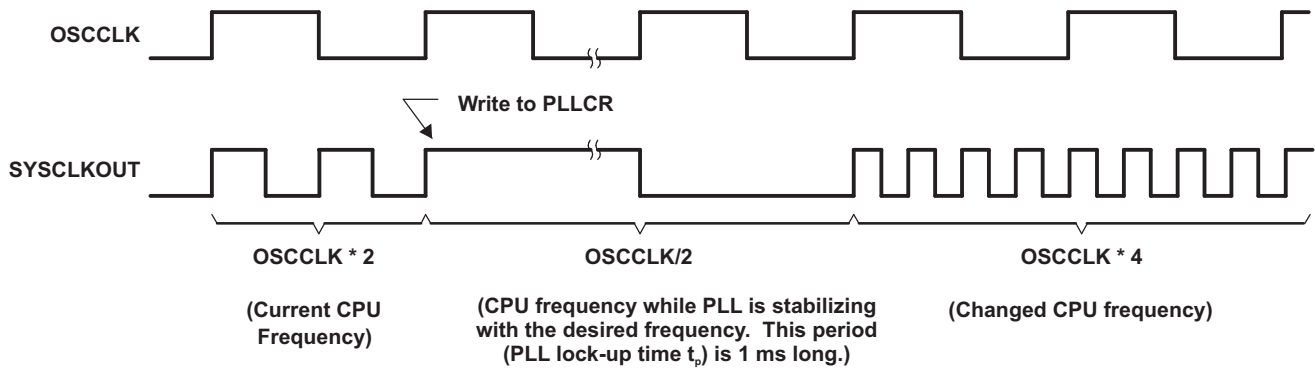

Figure 5-3. Example of Effect of Writing Into PLLCR Register

### 5.7.3 Clock Specifications

This section describes the oscillator and clocking mechanisms, the watchdog function and the low power modes.

**Table 5-3. PLL, Clocking, Watchdog, and Low-Power Mode Registers**

NAME	ADDRESS	SIZE (x16)	DESCRIPTION <sup>(1)</sup>
BORCFG	0x00 0985	1	BOR Configuration Register
XCLK	0x00 7010	1	XCLKOUT Control
PLLSTS	0x00 7011	1	PLL Status Register
CLKCTL	0x00 7012	1	Clock Control Register
PLLLOCKPRD	0x00 7013	1	PLL Lock Period
INTOSC1TRIM	0x00 7014	1	Internal Oscillator 1 Trim Register
INTOSC2TRIM	0x00 7016	1	Internal Oscillator 2 Trim Register
PCLKCR2	0x00 7019	1	Peripheral Clock Control Register 2
LOSPCP	0x00 701B	1	Low-Speed Peripheral Clock Prescaler Register
PCLKCR0	0x00 701C	1	Peripheral Clock Control Register 0
PCLKCR1	0x00 701D	1	Peripheral Clock Control Register 1
LPMCR0	0x00 701E	1	Low Power Mode Control Register 0
PCLKCR3	0x00 7020	1	Peripheral Clock Control Register 3
PLLCR	0x00 7021	1	PLL Control Register
SCSR	0x00 7022	1	System Control and Status Register
WDCNTR	0x00 7023	1	Watchdog Counter Register
WDKEY	0x00 7025	1	Watchdog Reset Key Register
WDCR	0x00 7029	1	Watchdog Control Register
JTAGDEBUG	0x00 702A	1	JTAG Port Debug Register
PLL2CTL	0x00 7030	1	PLL2 Configuration Register
PLL2MULT	0x00 7032	1	PLL2 Multiplier Register
PLL2STS	0x00 7034	1	PLL2 Lock Status Register
SYSCLK2CNTR	0x00 7036	1	SYSCLK2 Clock Counter Register
EPWMCFG	0x00 703A	1	ePWM DMA Configuration Register

(1) All registers in this table are EALLOW protected.

Figure 5-4 shows the various clock domains that are discussed. Figure 5-5 shows the various clock sources (both internal and external) that can provide a clock for device operation.

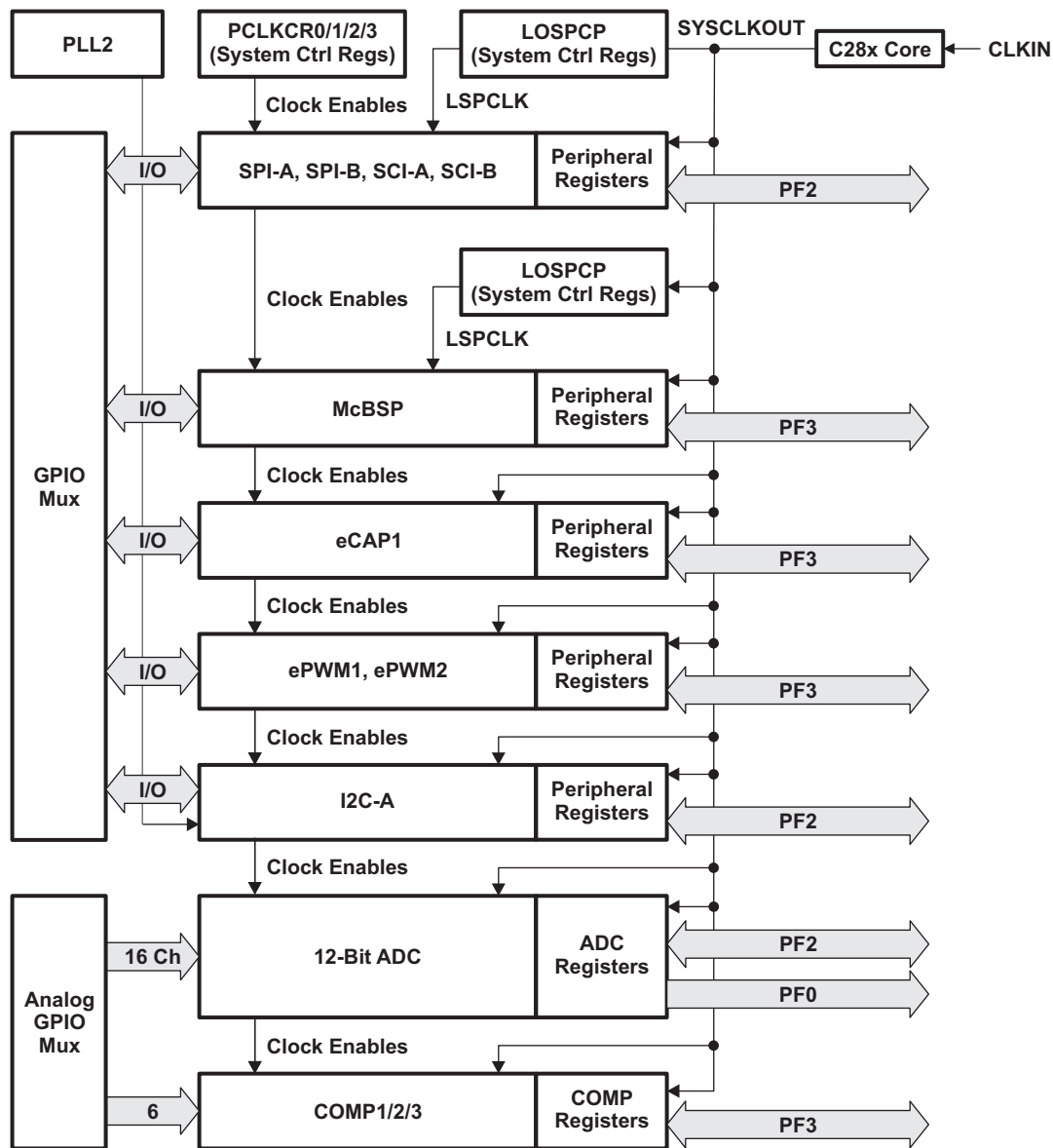

- A. CLKIN is the clock into the CPU. CLKIN is passed out of the CPU as SYSCLKOUT (that is, CLKIN is the same frequency as SYSCLKOUT).

**Figure 5-4. Clock and Reset Domains**

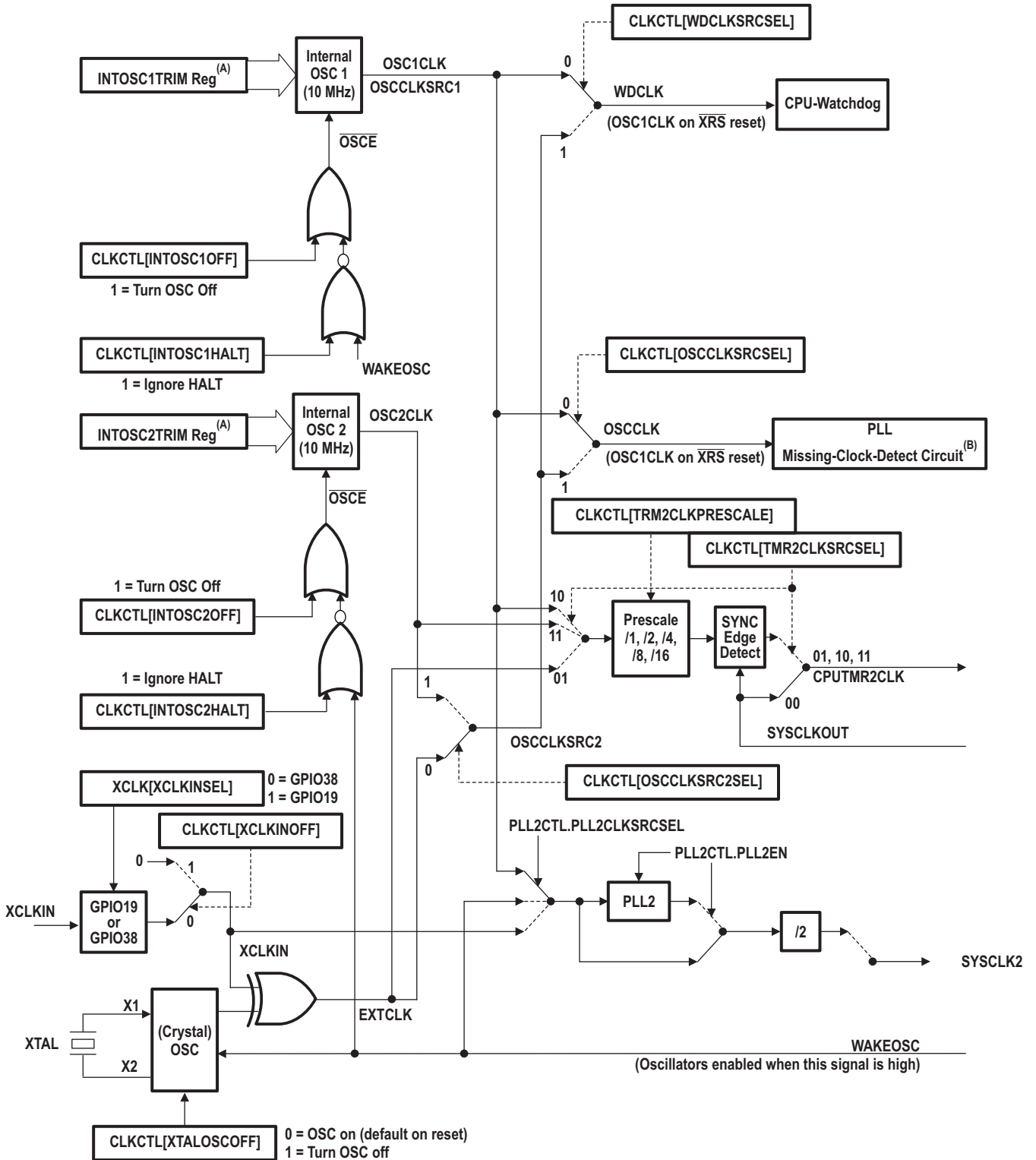

- A. Register loaded from TI OTP-based calibration function.
- B. See Section 5.7.3.5 for details on missing clock detection.

Figure 5-5. Clock Tree

### 5.7.3.1 Internal Zero Pin Oscillators

The F28PLC8x device contains two independent internal zero pin oscillators. By default both oscillators are turned on at power up, and internal oscillator 1 is the default clock source at this time. For power savings, unused oscillators may be powered down by the user. The center frequency of these oscillators is determined by their respective oscillator trim registers, written to in the calibration routine as part of the boot ROM execution. See [Section 5.7.3.8](#) for more information on these oscillators.

### 5.7.3.2 Crystal Oscillator Option

The typical specifications for the external quartz crystal (fundamental mode, parallel resonant) are listed in [Table 5-4](#). Furthermore, ESR range = 30 to 150  $\Omega$ .

**Table 5-4. Typical Specifications for External Quartz Crystal<sup>(1)</sup>**

FREQUENCY (MHz)	$R_d$ ( $\Omega$ )	$C_{L1}$ (pF)	$C_{L2}$ (pF)
5	2200	18	18
10	470	15	15
15	0	15	15
20	0	12	12

(1)  $C_{shunt}$  should be less than or equal to 5 pF.

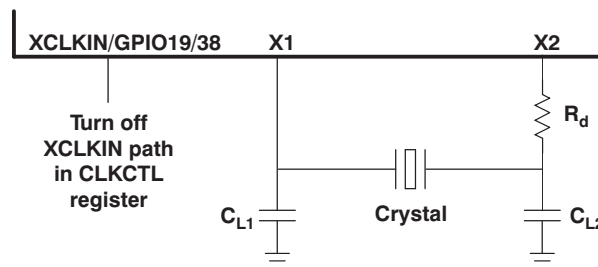

**Figure 5-6. Using the On-chip Crystal Oscillator**

#### NOTE

- $C_{L1}$  and  $C_{L2}$  are the total capacitance of the circuit board and components excluding the IC and crystal. The value is usually approximately twice the value of the crystal's load capacitance.
- The load capacitance of the crystal is described in the crystal specifications of the manufacturers.
- TI recommends that customers have the resonator/crystal vendor characterize the operation of their device with the F28PLC8x chip. The resonator/crystal vendor has the equipment and expertise to tune the tank circuit. The vendor can also advise the customer regarding the proper tank component values that will produce proper start up and stability over the entire operating range.

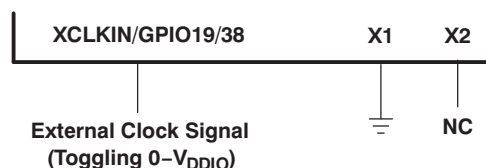

**Figure 5-7. Using a 3.3-V External Oscillator**

### 5.7.3.3 PLL-Based Clock Module

The F28PLC8x device has an on-chip, PLL-based clock module. This module provides all the necessary clocking signals for the device, as well as control for low-power mode entry. The PLL has a 5-bit ratio control PLLCR[DIV] to select different CPU clock rates. The watchdog module should be disabled before writing to the PLLCR register. The watchdog module can be re-enabled (if need be) after the PLL module has stabilized, which takes 1 ms. The input clock and PLLCR[DIV] bits should be chosen in such a way that the output frequency of the PLL (VCOCLK) is at least 50 MHz.

**Table 5-5. PLL Settings**

PLLCR[DIV] VALUE <sup>(1)</sup> <sup>(2)</sup>	SYSCLKOUT (CLKIN)		
	PLLSTS[DIVSEL] = 0 or 1 <sup>(3)</sup>	PLLSTS[DIVSEL] = 2	PLLSTS[DIVSEL] = 3
00000 (PLL bypass)	OSCCLK/4 (Default) <sup>(1)</sup>	OSCCLK/2	OSCCLK
00001	(OSCCLK * 1)/4	(OSCCLK * 1)/2	(OSCCLK * 1)/1
00010	(OSCCLK * 2)/4	(OSCCLK * 2)/2	(OSCCLK * 2)/1
00011	(OSCCLK * 3)/4	(OSCCLK * 3)/2	(OSCCLK * 3)/1
00100	(OSCCLK * 4)/4	(OSCCLK * 4)/2	(OSCCLK * 4)/1
00101	(OSCCLK * 5)/4	(OSCCLK * 5)/2	(OSCCLK * 5)/1
00110	(OSCCLK * 6)/4	(OSCCLK * 6)/2	(OSCCLK * 6)/1
00111	(OSCCLK * 7)/4	(OSCCLK * 7)/2	(OSCCLK * 7)/1
01000	(OSCCLK * 8)/4	(OSCCLK * 8)/2	(OSCCLK * 8)/1
01001	(OSCCLK * 9)/4	(OSCCLK * 9)/2	(OSCCLK * 9)/1
01010	(OSCCLK * 10)/4	(OSCCLK * 10)/2	(OSCCLK * 10)/1
01011	(OSCCLK * 11)/4	(OSCCLK * 11)/2	(OSCCLK * 11)/1
01100	(OSCCLK * 12)/4	(OSCCLK * 12)/2	(OSCCLK * 12)/1
01101	(OSCCLK * 13)/4	(OSCCLK * 13)/2	(OSCCLK * 13)/1
01110	(OSCCLK * 14)/4	(OSCCLK * 14)/2	(OSCCLK * 14)/1
01111	(OSCCLK * 15)/4	(OSCCLK * 15)/2	(OSCCLK * 15)/1
10000	(OSCCLK * 16)/4	(OSCCLK * 16)/2	(OSCCLK * 16)/1
10001	(OSCCLK * 17)/4	(OSCCLK * 17)/2	(OSCCLK * 17)/1
10010	(OSCCLK * 18)/4	(OSCCLK * 18)/2	(OSCCLK * 18)/1

- (1) The PLL control register (PLLCR) and PLL Status Register (PLLSTS) are reset to their default state by the  $\overline{\text{XRS}}$  signal or a watchdog reset only. A reset issued by the debugger or the missing clock detect logic has no effect.
- (2) This register is EALLOW protected.
- (3) By default, PLLSTS[DIVSEL] is configured for /4. (The boot ROM changes the PLLSTS[DIVSEL] configuration to /1.) PLLSTS[DIVSEL] must be 0 before writing to the PLLCR and should be changed only after PLLSTS[PLLLOCKS] = 1.

**Table 5-6. CLKIN Divide Options**

PLLSTS [DIVSEL]	CLKIN DIVIDE
0	/4
1	/4
2	/2
3	/1

The PLL-based clock module provides four modes of operation:

- **INTOSC1 (Internal Zero-pin Oscillator 1):** INTOSC1 is the on-chip internal oscillator 1. INTOSC1 can provide the clock for the Watchdog block, core and CPU-Timer 2
- **INTOSC2 (Internal Zero-pin Oscillator 2):** INTOSC2 is the on-chip internal oscillator 2. INTOSC2 can provide the clock for the Watchdog block, core and CPU-Timer 2. Both INTOSC1 and INTOSC2 can be independently chosen for the Watchdog block, core and CPU-Timer 2.
- **Crystal/Resonator Operation:** The on-chip (crystal) oscillator enables the use of an external crystal/resonator attached to the device to provide the time base. The crystal/resonator is connected to the X1/X2 pins.
- **External Clock Source Operation:** If the on-chip (crystal) oscillator is not used, this mode allows the oscillator to be bypassed. The device clocks are generated from an external clock source input on the XCLKIN pin. Note that the XCLKIN is multiplexed with GPIO19 or GPIO38 pin. The XCLKIN input can be selected as GPIO19 or GPIO38 via the XCLKINSEL bit in XCLK register. The CLKCTL[XCLKINOFF] bit disables this clock input (forced low). If the clock source is not used or the respective pins are used as GPIOs, the user should disable at boot time.

Before changing clock sources, ensure that the target clock is present. If a clock is not present, then that clock source must be disabled (using the CLKCTL register) before switching clocks.

**Table 5-7. Possible PLL Configuration Modes**

PLL MODE	REMARKS	PLLSTS[DIVSEL]	CLKIN AND SYSCLOCKOUT
PLL Off	Invoked by the user setting the PLOFF bit in the PLLSTS register. The PLL block is disabled in this mode. The PLL block being disabled can be useful in reducing system noise and for low power operation. The PLLCR register must first be set to 0x0000 (PLL Bypass) before entering this mode. The CPU clock (CLKIN) is derived directly from the input clock on either X1/X2, X1 or XCLKIN.	0, 1 2 3	OSCCLK/4 OSCCLK/2 OSCCLK/1
PLL Bypass	PLL Bypass is the default PLL configuration upon power-up or after an external reset (XRS). This mode is selected when the PLLCR register is set to 0x0000 or while the PLL locks to a new frequency after the PLLCR register has been modified. In this mode, the PLL itself is bypassed but the PLL is not turned off.	0, 1 2 3	OSCCLK/4 OSCCLK/2 OSCCLK/1
PLL Enable	Achieved by writing a non-zero value n into the PLLCR register. Upon writing to the PLLCR the device will switch to PLL Bypass mode until the PLL locks.	0, 1 2 3	OSCCLK * n/4 OSCCLK * n/2 OSCCLK * n/1

#### 5.7.3.4 Phase-Locked Loop Module (PLL2)

In addition to the main system PLL, the F28PLC8x device also contains a second PLL (PLL2). The PLL supports multipliers of 1 to 15 and has a fixed divide-by-two on its output.

PLL2 may be clocked from the following three sources by modifying the PLL2CLKSRCSEL bits appropriately in the PLL2CTL register:

- **INTOSC1 (Internal Zero-pin Oscillator 1):** INTOSC1 is the on-chip internal oscillator 1 and provides a 10-MHz clock.
- **Crystal/Resonator Operation:** The (crystal) oscillator enables the use of an external crystal or resonator attached to the device to provide the time base. The crystal or resonator is connected to the X1/X2 pins.
- **External Clock Source Operation:** This mode allows the reference clock to be derived from an external single-ended clock source connected to either GPIO19 or GPIO38. The XCLKINSEL bit in the XCLK register should be set appropriately to enable the selected GPIO to drive XCLKIN.

### 5.7.3.5 Loss of Input Clock (NMI Watchdog Function)

The F28PLC8x device may be clocked from either one of the internal zero-pin oscillators (INTOSC1 or INTOSC2), the on-chip crystal oscillator, or from an external clock input. Regardless of the clock source, in PLL-enabled and PLL-bypass mode, if the input clock to the PLL vanishes, the PLL will issue a limp-mode clock at its output. This limp-mode clock continues to clock the CPU and peripherals at a typical frequency of 1–5 MHz.

When the limp mode is activated, a  $\overline{\text{CLOCKFAIL}}$  signal is generated that is latched as an NMI interrupt. Depending on how the NMIRESETSEL bit has been configured, a reset to the device can be fired immediately or the NMI watchdog counter can issue a reset when the counter overflows. In addition to this action, the Missing Clock Status (MCLKSTS) bit is set. The NMI interrupt could be used by the application to detect the input clock failure and initiate necessary corrective action such as switching over to an alternative clock source (if available) or initiate a shut-down procedure for the system.

If the software does not respond to the clock-fail condition, the NMI watchdog triggers a reset after a preprogrammed time interval. Figure 5-8 shows the interrupt mechanisms involved.

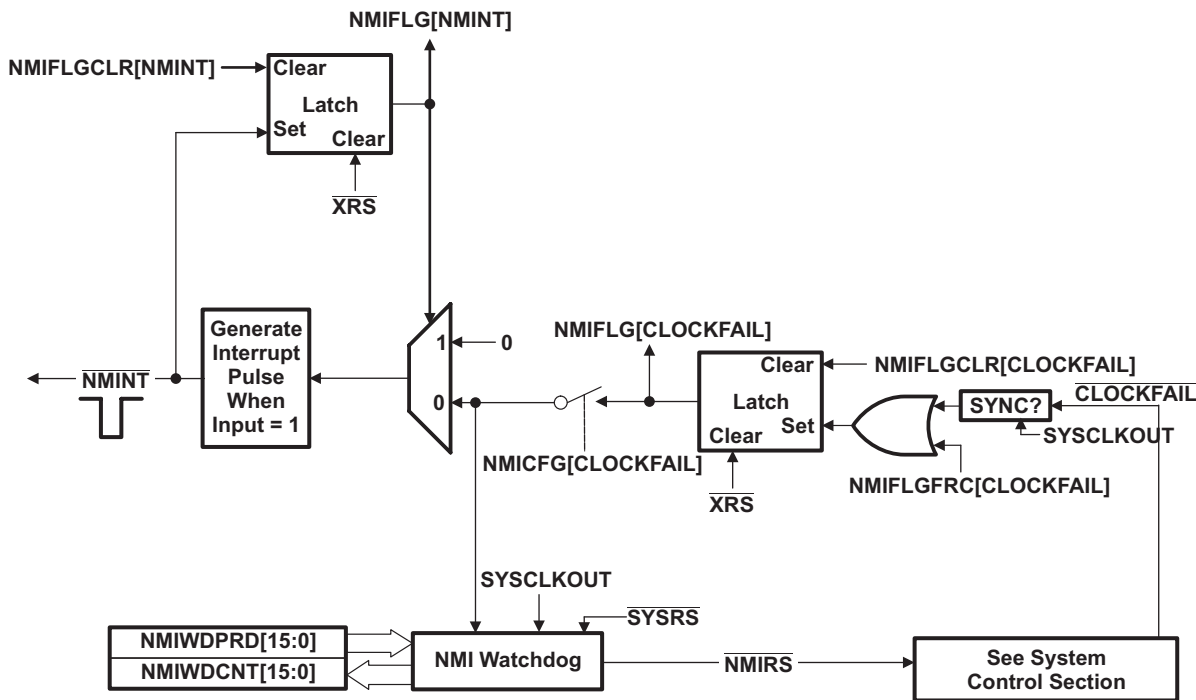

Figure 5-8. NMI-Watchdog

### 5.7.3.6 CPU-Watchdog Module

The CPU-watchdog module on the F28PLC8x device is similar to the one used on the 281x, 280x, and 283xx devices. This module generates an output pulse, 512 oscillator clocks wide (OSCCLK), whenever the 8-bit watchdog up counter has reached its maximum value. To prevent this occurrence, the user must disable the counter or the software must periodically write a 0x55 + 0xAA sequence into the watchdog key register that resets the watchdog counter. Figure 5-9 shows the various functional blocks within the watchdog module.

Normally, when the input clocks are present, the CPU-watchdog counter decrements to initiate a CPU-watchdog reset or WDINT interrupt. However, when the external input clock fails, the CPU-watchdog counter stops decrementing (that is, the watchdog counter does not change with the limp-mode clock).

**NOTE**

The CPU-watchdog is different from the NMI watchdog. The CPU-watchdog is the legacy watchdog that is present in all 28x devices.

**NOTE**

Applications in which the correct CPU operating frequency is absolutely critical should implement a mechanism by which the F28PLC8x device will be held in reset, should the input clocks ever fail. For example, an R-C circuit may be used to trigger the  $\overline{\text{XRS}}$  pin of the device, should the capacitor ever get fully charged. An I/O pin may be used to discharge the capacitor on a periodic basis to prevent the capacitor from getting fully charged. Such a circuit would also help in detecting failure of the flash memory.

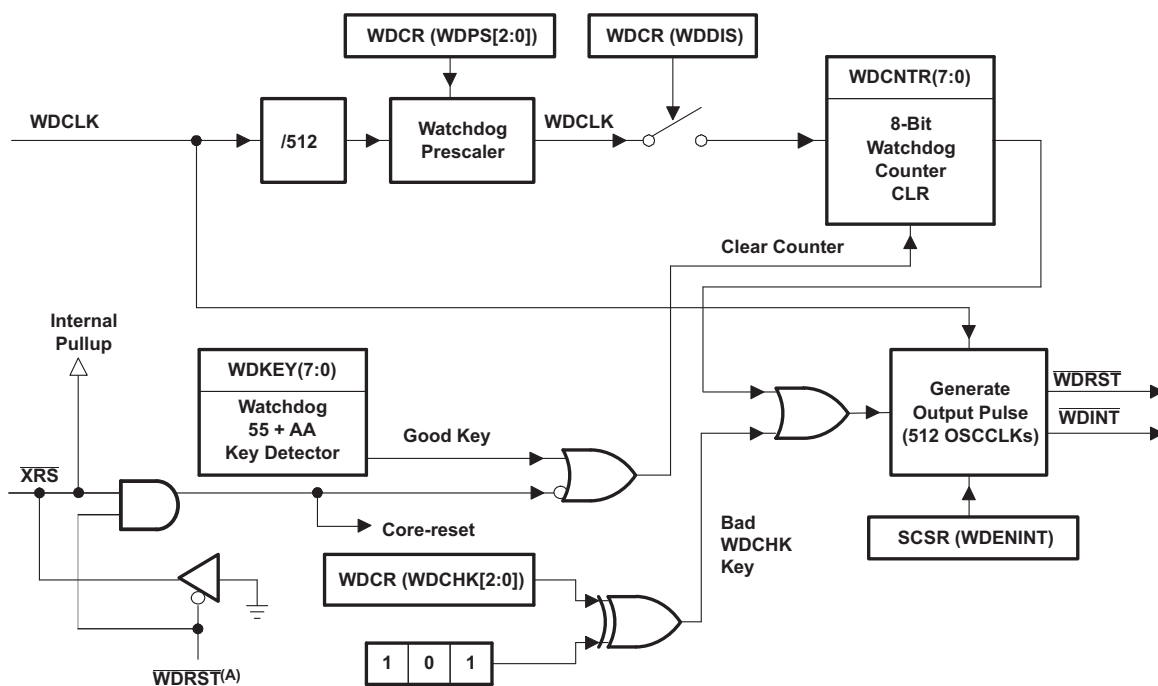

A. The  $\overline{\text{WDRST}}$  signal is driven low for 512 OSCCLK cycles.

**Figure 5-9. CPU-Watchdog Module**

The  $\overline{\text{WDINT}}$  signal enables the watchdog to be used as a wakeup from IDLE/STANDBY mode.

In STANDBY mode, all peripherals are turned off on the device. The only peripheral that remains functional is the CPU-watchdog. This module will run off OSCCLK. The  $\overline{\text{WDINT}}$  signal is fed to the low-power mode (LPM) block so that the signal can wake the device from STANDBY (if enabled). See [Section 5.7.3.7, Low-power Modes Block](#), for more details.

In IDLE mode, the  $\overline{\text{WDINT}}$  signal can generate an interrupt to the CPU, via the Peripheral Interrupt Expansion (PIE), to take the CPU out of IDLE mode.

In HALT mode, the CPU-watchdog can be used to wake up the device through a device reset.

### 5.7.3.7 Low-power Modes Block

Table 5-8 summarizes the various modes.

**Table 5-8. Low-power Modes**

MODE	LPMCR0(1:0)	OSCCLK	CLKIN	SYSCLKOUT	EXIT <sup>(1)</sup>
IDLE	00	On	On	On	$\overline{XRS}$ , CPU-watchdog interrupt, any enabled interrupt
STANDBY	01	On (CPU-watchdog still running)	Off	Off	$\overline{XRS}$ , CPU-watchdog interrupt, GPIO Port A signal, debugger <sup>(2)</sup>
HALT <sup>(3)</sup>	1X	Off (on-chip crystal oscillator and PLL turned off, zero-pin oscillator and CPU-watchdog state dependent on user code.)	Off	Off	$\overline{XRS}$ , GPIO Port A signal, debugger <sup>(2)</sup> , CPU-watchdog

- (1) The Exit column lists which signals or under what conditions the low power mode is exited. A low signal, on any of the signals, exits the low power condition. This signal must be kept low long enough for an interrupt to be recognized by the device. Otherwise, the low-power mode will not be exited and the device will go back into the indicated low power mode.
- (2) The JTAG port can still function even if the CPU clock (CLKIN) is turned off.
- (3) The WDCLK must be active for the device to go into HALT mode.

The various low-power modes operate as follows:

- IDLE Mode:** This mode is exited by any enabled interrupt that is recognized by the processor. The LPM block performs no tasks during this mode as long as the LPMCR0(LPM) bits are set to 0,0.
- STANDBY Mode:** Any GPIO port A signal (GPIO[31:0]) can wake the device from STANDBY mode. The user must select which signals will wake the device in the GPIOLPMSEL register. The selected signals are also qualified by the OSCCLK before waking the device. The number of OSCCLKs is specified in the LPMCR0 register.
- HALT Mode:** CPU-watchdog,  $\overline{XRS}$ , and any GPIO port A signal (GPIO[31:0]) can wake the device from HALT mode. The user selects the signal in the GPIOLPMSEL register.

---

**NOTE**

The low-power modes do not affect the state of the output pins (PWM pins included). They will be in whatever state the code left them in when the IDLE instruction was executed.

---

### 5.7.3.8 Device Clock Table

This section provides the timing requirements and switching characteristics for the various clock options available on the F28PLC8x device. [Table 5-9](#) lists the cycle times of various clocks.

**Table 5-9. F28PLC8x Clock Table and Nomenclature**

		MIN	NOM	MAX	UNIT
SYSCLKOUT	$t_{c(SCO)}$ , Cycle time	11.11		500	ns
	Frequency	2		90	MHz
LSPCLK <sup>(1)</sup>	$t_{c(LCO)}$ , Cycle time	11.11	44.4 <sup>(2)</sup>		ns
	Frequency		22.5 <sup>(2)</sup>	90	MHz
ADC clock	$t_{c(ADCCLK)}$ , Cycle time	22.22			ns
	Frequency			45	MHz

(1) Lower LSPCLK will reduce device power consumption.

(2) This value is the default reset value if SYSCLKOUT = 90 MHz.

**Table 5-10. Device Clocking Requirements/Characteristics**

		MIN	NOM	MAX	UNIT
On-chip oscillator (X1/X2 pins) (Crystal/Resonator)	$t_{c(OSC)}$ , Cycle time	50		200	ns
	Frequency	5		20	MHz
External oscillator/clock source (XCLKIN pin) — PLL Enabled	$t_{c(CI)}$ , Cycle time (C8)	33.3		200	ns
	Frequency	5		30	MHz
External oscillator/clock source (XCLKIN pin) — PLL Disabled	$t_{c(CI)}$ , Cycle time (C8)	11.11		250	ns
	Frequency	4		90	MHz
Limp mode SYSCLKOUT (with /2 enabled)	Frequency range		1 to 5		MHz
XCLKOUT	$t_{c(XCO)}$ , Cycle time (C1)	44.44		2000	ns
	Frequency	0.5		22.5	MHz
PLL lock time <sup>(1)</sup>	$t_p$			1	ms

(1) The PLLLOCKPRD register must be updated based on the number of OSCCLK cycles. If the zero-pin internal oscillators (10 MHz) are used as the clock source, then the PLLLOCKPRD register must be written with a value of 10,000 (minimum).

**Table 5-11. Internal Zero-Pin Oscillator (INTOSC1, INTOSC2) Characteristics**

PARAMETER		MIN	TYP	MAX	UNIT
Internal zero-pin oscillator 1 (INTOSC1) at 30°C <sup>(1)(2)</sup>	Frequency		10.000		MHz
Internal zero-pin oscillator 2 (INTOSC2) at 30°C <sup>(1)(2)</sup>	Frequency		10.000		MHz
Step size (coarse trim)			55		kHz
Step size (fine trim)			14		kHz
Temperature drift <sup>(3)</sup>			3.03	4.85	kHz/°C
Voltage (V <sub>DD</sub> ) drift <sup>(3)</sup>			175		Hz/mV

- (1) In order to achieve better oscillator accuracy (10 MHz ± 1% or better) than shown, refer to the *Oscillator Compensation Guide Application Report* ([SPRAB84](#)).
- (2) Frequency range ensured only when VREG is enabled,  $\overline{VREGENZ} = V_{SS}$ .
- (3) Output frequency of the internal oscillators follows the direction of both the temperature gradient and voltage (V<sub>DD</sub>) gradient. For example:
- Increase in temperature will cause the output frequency to increase per the temperature coefficient.
  - Decrease in voltage (V<sub>DD</sub>) will cause the output frequency to decrease per the voltage coefficient.

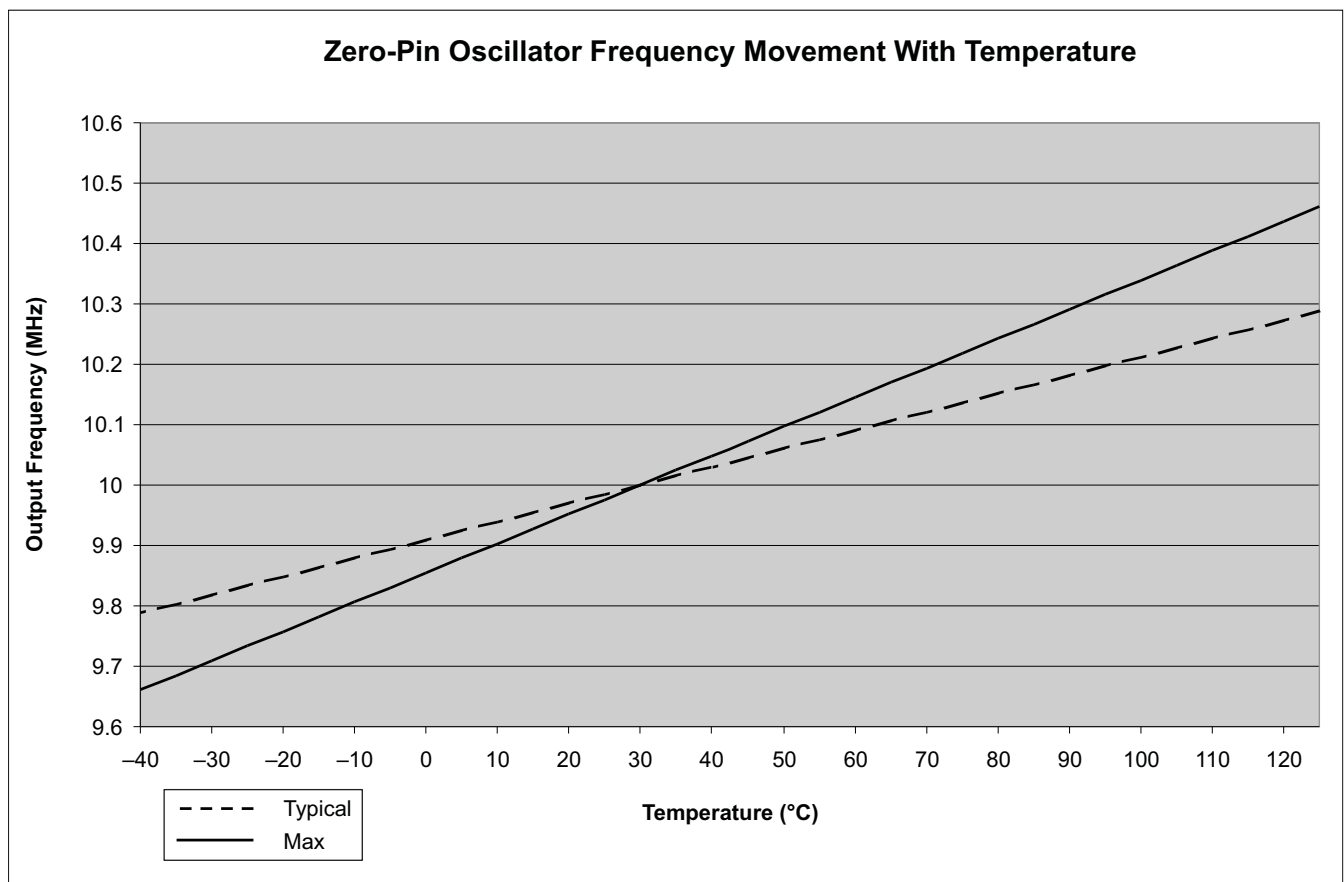

**Figure 5-10. Zero-Pin Oscillator Frequency Movement With Temperature**

5.7.3.9 Clock Requirements and Characteristics

Table 5-12. XCLKIN Timing Requirements - PLL Enabled

NO.			MIN	MAX	UNIT
C9	$t_{f(CI)}$	Fall time, XCLKIN		6	ns
C10	$t_{r(CI)}$	Rise time, XCLKIN		6	ns
C11	$t_{w(CIL)}$	Pulse duration, XCLKIN low as a percentage of $t_{c(OSCCLK)}$	45%	55%	
C12	$t_{w(CIH)}$	Pulse duration, XCLKIN high as a percentage of $t_{c(OSCCLK)}$	45%	55%	

Table 5-13. XCLKIN Timing Requirements - PLL Disabled

NO.			MIN	MAX	UNIT
C9	$t_{f(CI)}$	Fall time, XCLKIN	Up to 20 MHz	6	ns
			20 MHz to 90 MHz	2	
C10	$t_{r(CI)}$	Rise time, XCLKIN	Up to 20 MHz	6	ns
			20 MHz to 90 MHz	2	
C11	$t_{w(CIL)}$	Pulse duration, XCLKIN low as a percentage of $t_{c(OSCCLK)}$	45%	55%	
C12	$t_{w(CIH)}$	Pulse duration, XCLKIN high as a percentage of $t_{c(OSCCLK)}$	45%	55%	

The possible configuration modes are shown in Table 5-7.

Table 5-14. XCLKOUT Switching Characteristics (PLL Bypassed or Enabled)<sup>(1)(2)</sup>

over recommended operating conditions (unless otherwise noted)

NO.	PARAMETER	MIN	MAX	UNIT
C3	$t_{f(XCO)}$ Fall time, XCLKOUT		5	ns
C4	$t_{r(XCO)}$ Rise time, XCLKOUT		5	ns
C5	$t_{w(XCOL)}$ Pulse duration, XCLKOUT low	H - 2	H + 2	ns
C6	$t_{w(XCOH)}$ Pulse duration, XCLKOUT high	H - 2	H + 2	ns

(1) A load of 40 pF is assumed for these parameters.

(2)  $H = 0.5t_{c(XCO)}$

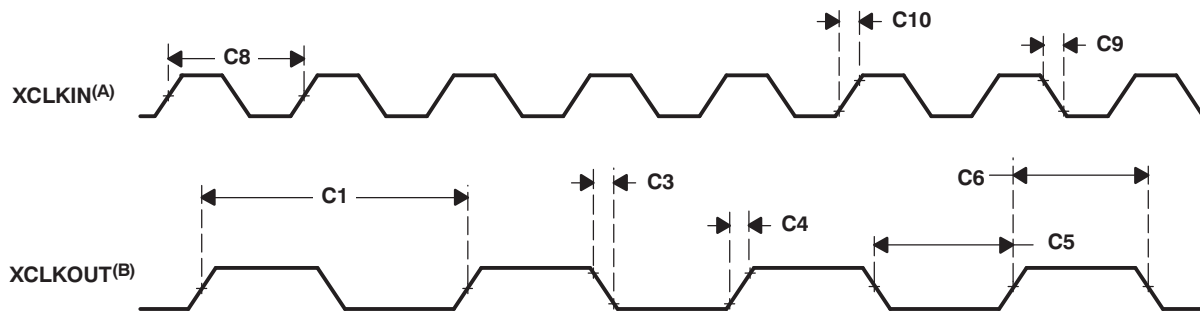

- A. The relationship of XCLKIN to XCLKOUT depends on the divide factor chosen. The waveform relationship shown is intended to illustrate the timing parameters only and may differ based on actual configuration.
- B. XCLKOUT configured to reflect SYSCLKOUT.

Figure 5-11. Clock Timing

## 5.7.4 Peripherals

### 5.7.4.1 Analog Block

A 12-bit ADC core is implemented that has different timings than the 12-bit ADC used on F280x/F2833x. The ADC wrapper is modified to incorporate the new timings and also other enhancements to improve the timing control of start of conversions. Figure 5-12 shows the interaction of the analog module with the rest of the F28PLCx system.

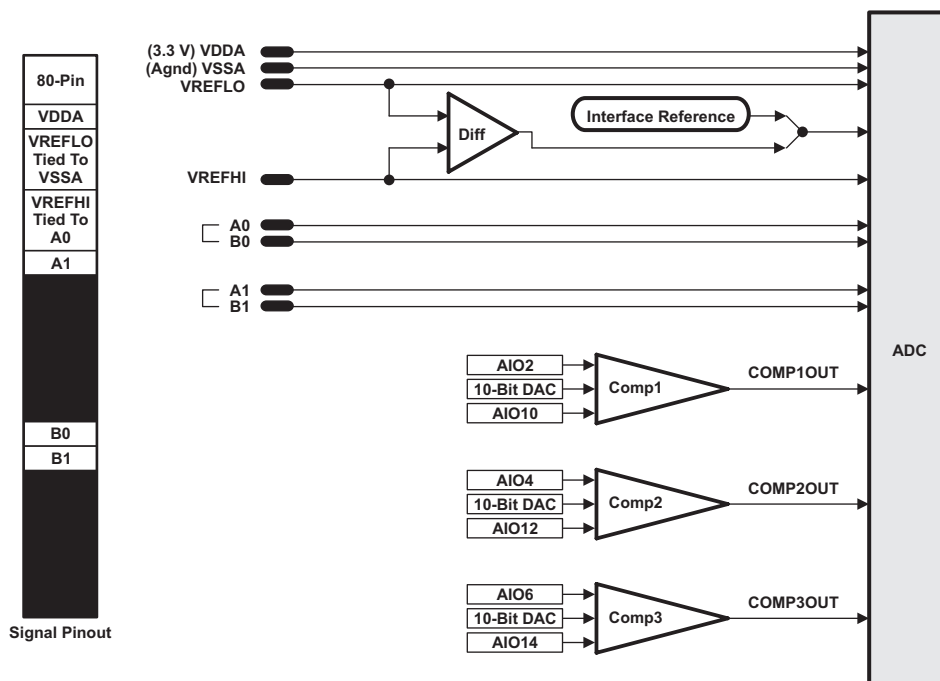

Figure 5-12. Analog Pin Configurations

### 5.7.4.1.1 Analog-to-Digital Converter

#### 5.7.4.1.1.1 Features

The core of the ADC contains a single 12-bit converter fed by two sample-and-hold circuits. The sample-and-hold circuits can be sampled simultaneously or sequentially. These, in turn, are fed by a total of up to 16 analog input channels. The converter can be configured to run with an internal bandgap reference to create true-voltage based conversions or with a pair of external voltage references ( $V_{REFHI}/V_{REFLO}$ ) to create ratiometric-based conversions.

Contrary to previous ADC types, this ADC is not sequencer-based. The user can easily create a series of conversions from a single trigger. However, the basic principle of operation is centered around the configurations of individual conversions, called SOCs, or Start-Of-Conversions.

Functions of the ADC module include:

- 12-bit ADC core with built-in dual sample-and-hold (S/H)
- Simultaneous sampling or sequential sampling modes
- Full range analog input: 0 V to 3.3 V fixed, or  $V_{REFHI}/V_{REFLO}$  ratiometric. The digital value of the input analog voltage is derived by:

- Internal Reference ( $V_{REFLO} = V_{SSA}$ .  $V_{REFHI}$  must not exceed  $V_{DDA}$  when using either internal or external reference modes.)

$$\text{Digital Value} = 0, \quad \text{when input} \leq 0 \text{ V}$$

$$\text{Digital Value} = 4096 \times \frac{\text{Input Analog Voltage} - V_{REFLO}}{3.3} \quad \text{when } 0 \text{ V} < \text{input} < 3.3 \text{ V}$$

$$\text{Digital Value} = 4095, \quad \text{when input} \geq 3.3 \text{ V}$$

- External Reference ( $V_{REFHI}/V_{REFLO}$  connected to external references.  $V_{REFHI}$  must not exceed  $V_{DDA}$  when using either internal or external reference modes.)

$$\text{Digital Value} = 0, \quad \text{when input} \leq 0 \text{ V}$$

$$\text{Digital Value} = 4096 \times \frac{\text{Input Analog Voltage} - V_{REFLO}}{V_{REFHI} - V_{REFLO}} \quad \text{when } 0 \text{ V} < \text{input} < V_{REFHI}$$

$$\text{Digital Value} = 4095, \quad \text{when input} \geq V_{REFHI}$$

- Up to 16-channel, multiplexed inputs
- 16 SOCs, configurable for trigger, sample window, and channel
- 16 result registers (individually addressable) to store conversion values
- Multiple trigger sources
  - S/W – software immediate start
  - ePWM 1, ePWM2
  - GPIO XINT2
  - CPU Timer 0, CPU Timer 1, CPU Timer 2
  - ADCINT1, ADCINT2
- 9 flexible PIE interrupts, can configure interrupt request after any conversion

**Table 5-15. ADC Configuration and Control Registers**

REGISTER NAME	ADDRESS	SIZE (x16)	EALLOW PROTECTED	DESCRIPTION
ADCCTL1	0x7100	1	Yes	Control 1 Register
ADCCTL2	0x7101	1	Yes	Control 2 Register
ADCINTFLG	0x7104	1	No	Interrupt Flag Register
ADCINTFLGCLR	0x7105	1	No	Interrupt Flag Clear Register
ADCINTOVF	0x7106	1	No	Interrupt Overflow Register
ADCINTOVFCLR	0x7107	1	No	Interrupt Overflow Clear Register
INTSEL1N2	0x7108	1	Yes	Interrupt 1 and 2 Selection Register
INTSEL3N4	0x7109	1	Yes	Interrupt 3 and 4 Selection Register
INTSEL5N6	0x710A	1	Yes	Interrupt 5 and 6 Selection Register
INTSEL7N8	0x710B	1	Yes	Interrupt 7 and 8 Selection Register
INTSEL9N10	0x710C	1	Yes	Interrupt 9 Selection Register (reserved Interrupt 10 Selection)
SOCPRCTL	0x7110	1	Yes	SOC Priority Control Register
ADCSAMPLEMODE	0x7112	1	Yes	Sampling Mode Register
ADCINTSOCSEL1	0x7114	1	Yes	Interrupt SOC Selection 1 Register (for 8 channels)
ADCINTSOCSEL2	0x7115	1	Yes	Interrupt SOC Selection 2 Register (for 8 channels)
ADCSOCFLG1	0x7118	1	No	SOC Flag 1 Register (for 16 channels)
ADCSOCFRC1	0x711A	1	No	SOC Force 1 Register (for 16 channels)
ADCSOCOVF1	0x711C	1	No	SOC Overflow 1 Register (for 16 channels)
ADCSOCOVFCLR1	0x711E	1	No	SOC Overflow Clear 1 Register (for 16 channels)
ADCSOC0CTL to ADCSOC15CTL	0x7120 – 0x712F	1	Yes	SOC0 Control Register to SOC15 Control Register
ADCREFTTRIM	0x7140	1	Yes	Reference Trim Register
ADCOFFTRIM	0x7141	1	Yes	Offset Trim Register
COMPHYSTCTL	0x714C	1	Yes	Comparator Hysteresis Control Register
ADCREV	0x714F	1	No	Revision Register

**Table 5-16. ADC Result Registers (Mapped to PF0)**

REGISTER NAME	ADDRESS	SIZE (x16)	EALLOW PROTECTED	DESCRIPTION
ADCRESULT0 to ADCRESULT15	0xB00 – 0xB0F	1	No	ADC Result 0 Register to ADC Result 15 Register

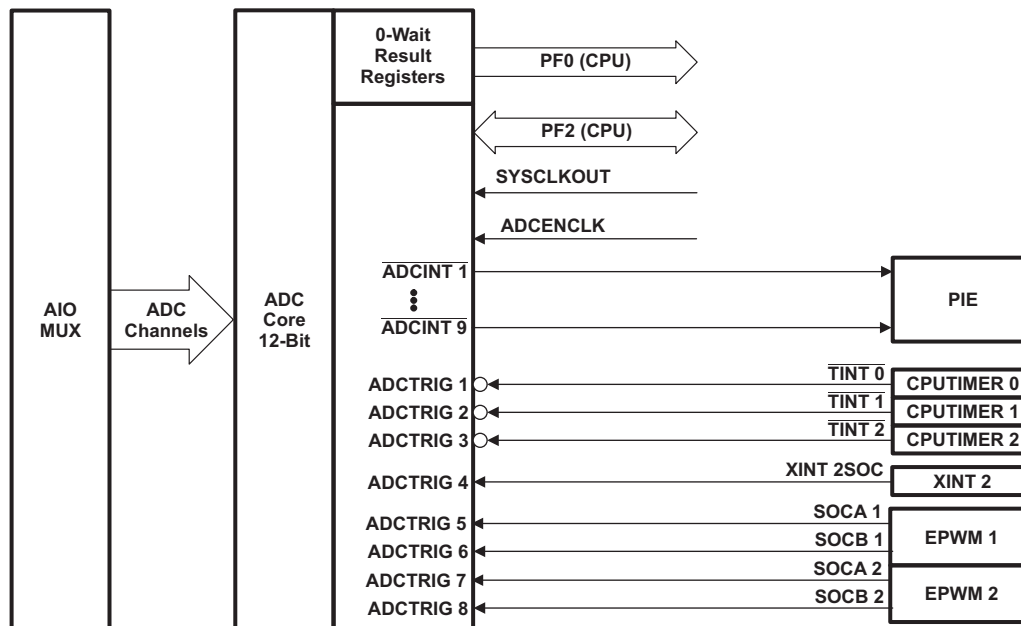

**Figure 5-13. ADC Connections**

#### **ADC Connections if the ADC is Not Used**

TI recommends that the connections for the analog power pins be kept, even if the ADC is not used. Following is a summary of how the ADC pins should be connected, if the ADC is not used in an application:

- $V_{DDA}$  – Connect to  $V_{DDIO}$
- $V_{SSA}$  – Connect to  $V_{SS}$
- $V_{REFLO}$  – Connect to  $V_{SS}$
- $ADCINAn$ ,  $ADCINBn$ ,  $V_{REFHI}$  – Connect to  $V_{SSA}$

When the ADC module is used in an application, unused ADC input pins should be connected to analog ground ( $V_{SSA}$ ).

**NOTE:** Unused ADCIN pins that are multiplexed with AIO function should not be directly connected to analog ground. They should be grounded through a 1-k $\Omega$  resistor. Grounding through a 1-k $\Omega$  resistor is to prevent an errant code from configuring these pins as AIO outputs and driving grounded pins to a logic-high state.

When the ADC is not used, be sure that the clock to the ADC module is not turned on to realize power savings.

### 5.7.4.1.1.2 ADC Start-of-Conversion Electrical Data/Timing

**Table 5-17. External ADC Start-of-Conversion Switching Characteristics**

over recommended operating conditions (unless otherwise noted)

PARAMETER	MIN	MAX	UNIT
$t_{w(ADCSOCL)}$ Pulse duration, $\overline{ADCSOCxO}$ low	$32t_{c(HCO)}$		cycles

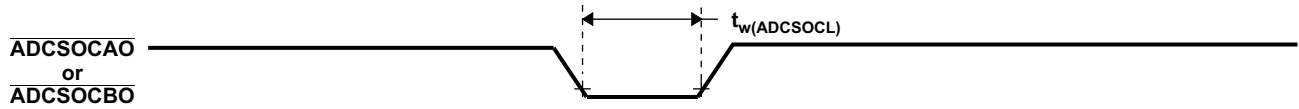

**Figure 5-14. ADCSOCAO or ADCSOCBO Timing**

### 5.7.4.1.1.3 ADC Electrical Data/Timing

**Table 5-18. ADC Electrical Characteristics**

PARAMETER	MIN	TYP	MAX	UNIT
<b>DC SPECIFICATIONS</b>				
Resolution	12			Bits
ADC clock	90-MHz device	0.001	45	MHz
Sample Window	7		64	ADC Clocks
<b>ACCURACY</b>				
INL (Integral nonlinearity) <sup>(1)</sup>	-4		4	LSB
DNL (Differential nonlinearity), no missing codes	-1		1.5	LSB
Offset error <sup>(2)</sup>	Executing a single self-recalibration	-20	20	LSB
	Executing periodic self-recalibration <sup>(3)</sup>	-4	4	
Overall gain error with internal reference	-60		60	LSB
Overall gain error with external reference	-40		40	LSB
Channel-to-channel offset variation	-4		4	LSB
Channel-to-channel gain variation	-4		4	LSB
ADC temperature coefficient with internal reference		-50		ppm/°C
ADC temperature coefficient with external reference		-20		ppm/°C
$V_{REFLO}$		-100		μA
$V_{REFHI}$		100		μA
<b>ANALOG INPUT</b>				
Analog input voltage with internal reference	0		3.3	V
Analog input voltage with external reference	$V_{REFLO}$		$V_{REFHI}$	V
$V_{REFLO}$ input voltage <sup>(4)</sup>	$V_{SSA}$		0.66	V
$V_{REFHI}$ input voltage <sup>(5)</sup>		2.64	$V_{DDA}$	V
	with $V_{REFLO} = V_{SSA}$	1.98	$V_{DDA}$	
Input capacitance		5		pF
Input leakage current		±2		μA

- (1) INL will degrade when the ADC input voltage goes above  $V_{DDA}$ .
- (2) 1 LSB has the weighted value of full-scale range (FSR)/4096. FSR is 3.3 V with internal reference and  $V_{REFHI} - V_{REFLO}$  for external reference.
- (3) Periodic self-recalibration will remove system-level and temperature dependencies on the ADC zero offset error.
- (4)  $V_{REFLO}$  is always connected to  $V_{SSA}$  on the 80-pin PN device.
- (5)  $V_{REFHI}$  must not exceed  $V_{DDA}$  when using either internal or external reference modes. Since  $V_{REFHI}$  is tied to ADCINA0 on the 80-pin PN device, the input signal on ADCINA0 must not exceed  $V_{DDA}$ .

**Table 5-19. ADC Power Modes**

ADC OPERATING MODE	CONDITIONS	I <sub>DDA</sub>	UNITS
Mode A – Operating Mode	ADC Clock Enabled Bandgap On (ADCBGPWD = 1) Reference On (ADCREFPWD = 1) ADC Powered Up (ADCPWDN = 1)	16	mA
Mode B – Quick Wake Mode	ADC Clock Enabled Bandgap On (ADCBGPWD = 1) Reference On (ADCREFPWD = 1) ADC Powered Up (ADCPWDN = 0)	4	mA
Mode C – Comparator-Only Mode	ADC Clock Enabled Bandgap On (ADCBGPWD = 1) Reference On (ADCREFPWD = 0) ADC Powered Up (ADCPWDN = 0)	1.5	mA
Mode D – Off Mode	ADC Clock Enabled Bandgap On (ADCBGPWD = 0) Reference On (ADCREFPWD = 0) ADC Powered Up (ADCPWDN = 0)	0.075	mA

**5.7.4.1.1.3.1 Internal Temperature Sensor****Table 5-20. Temperature Sensor Coefficient**

PARAMETER <sup>(1)</sup>		MIN	TYP	MAX	UNIT
T <sub>SLOPE</sub>	Degrees C of temperature movement per measured ADC LSB change of the temperature sensor		0.18 <sup>(2)(3)</sup>		°C/LSB
T <sub>OFFSET</sub>	ADC output at 0°C of the temperature sensor		1750		LSB

- (1) The temperature sensor slope and offset are given in terms of ADC LSBs using the internal reference of the ADC. Values must be adjusted accordingly in external reference mode to the external reference voltage.
- (2) ADC temperature coefficient is accounted for in this specification
- (3) Output of the temperature sensor (in terms of LSBs) is sign-consistent with the direction of the temperature movement. Increasing temperatures will give increasing ADC values relative to an initial value; decreasing temperatures will give decreasing ADC values relative to an initial value.

5.7.4.1.1.3.2 ADC Power-Up Control Bit Timing

Table 5-21. ADC Power-Up Delays

PARAMETER <sup>(1)</sup>		MIN	MAX	UNIT
$t_{d(PWD)}$	Delay time for the ADC to be stable after power up		1	ms

(1) Timings maintain compatibility to the ADC module. The F28PLCx ADC supports driving all 3 bits at the same time  $t_{d(PWD)}$  ms before first conversion.

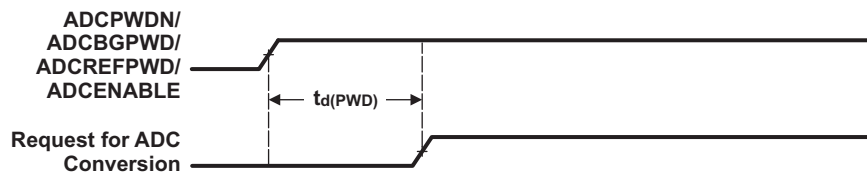
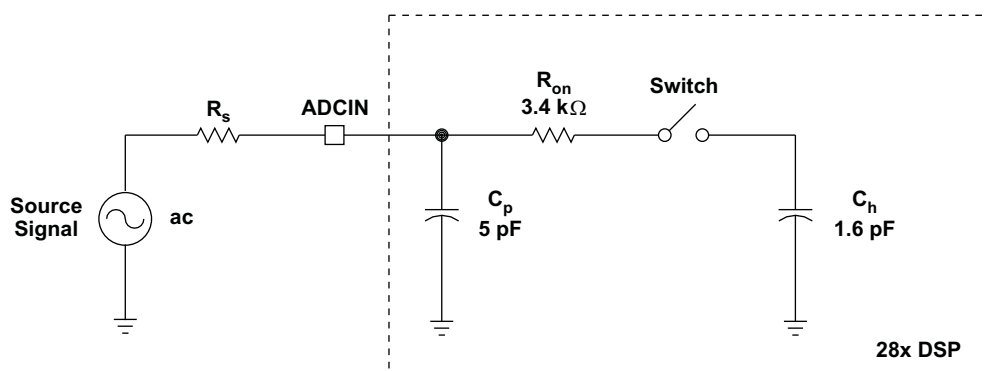

Figure 5-15. ADC Conversion Timing



Typical Values of the Input Circuit Components:

- Switch Resistance ( $R_{on}$ ): 3.4 kΩ
- Sampling Capacitor ( $C_h$ ): 1.6 pF
- Parasitic Capacitance ( $C_p$ ): 5 pF
- Source Resistance ( $R_s$ ): 50 Ω

Figure 5-16. ADC Input Impedance Model

**5.7.4.1.1.3.3 ADC Sequential and Simultaneous Timings**

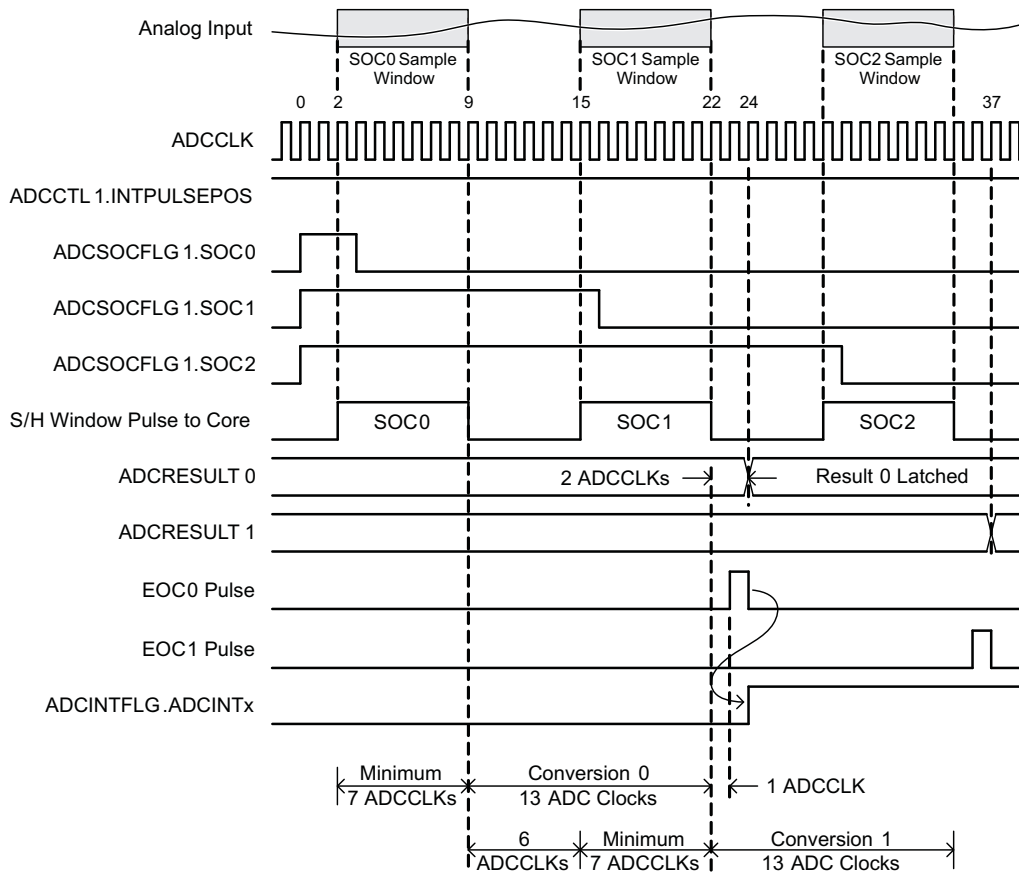

**Figure 5-17. Timing Example for Sequential Mode / Late Interrupt Pulse**

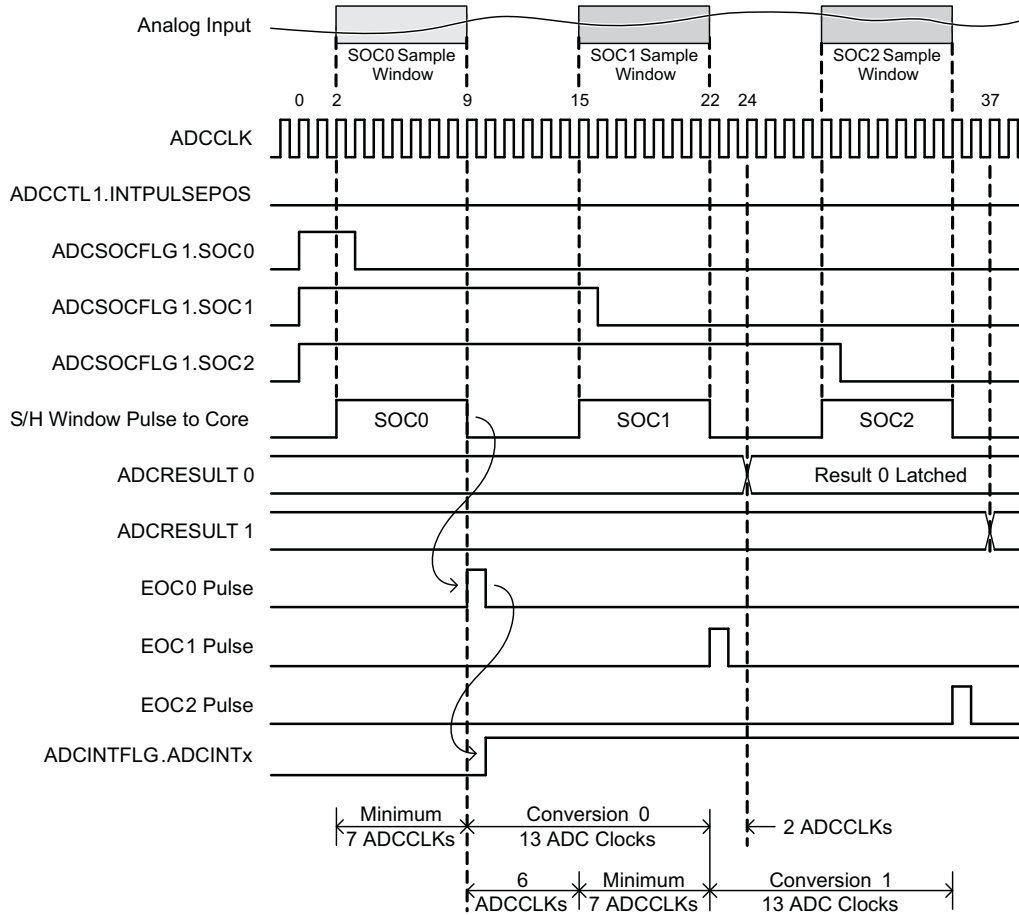

Figure 5-18. Timing Example for Sequential Mode / Early Interrupt Pulse

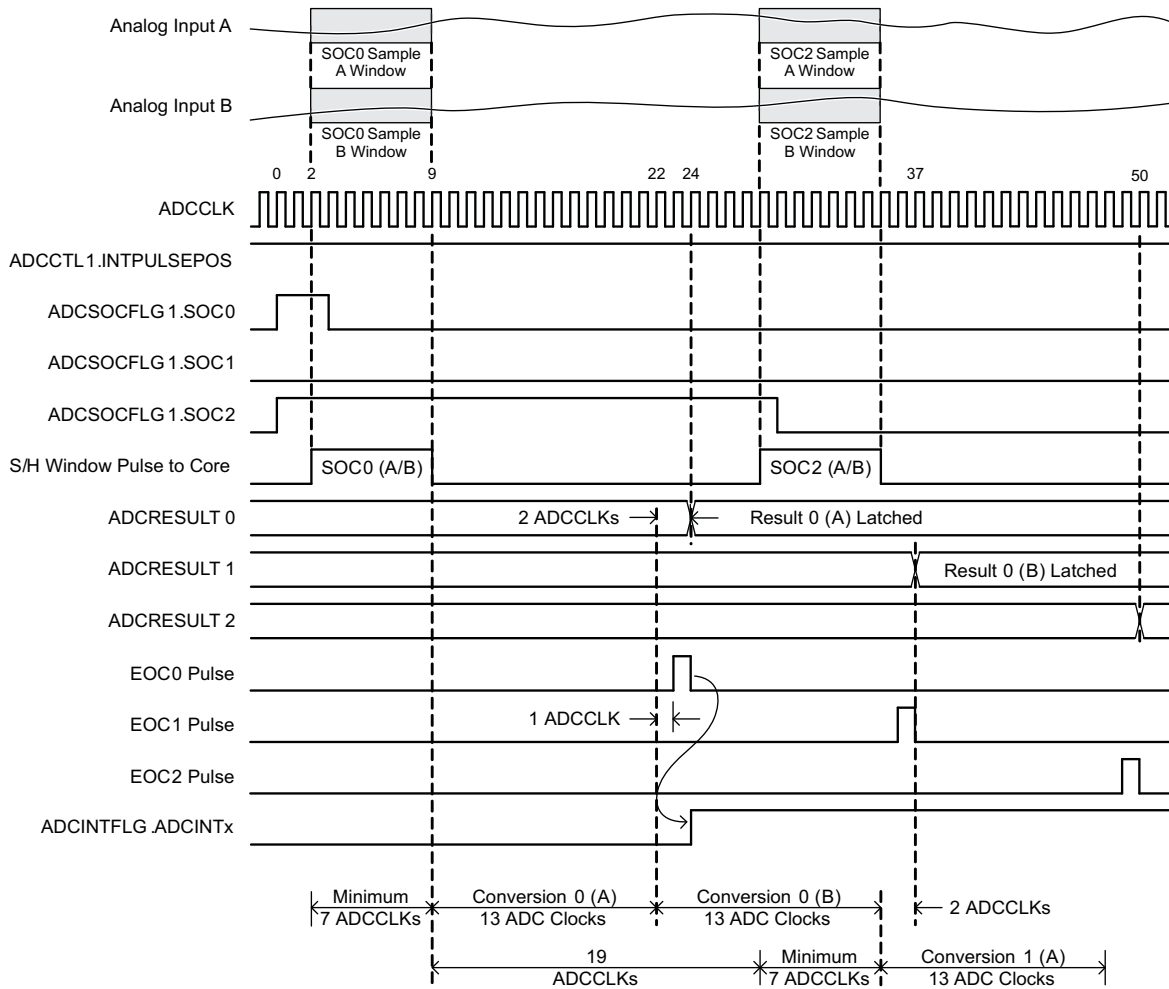

Figure 5-19. Timing Example for Simultaneous Mode / Late Interrupt Pulse

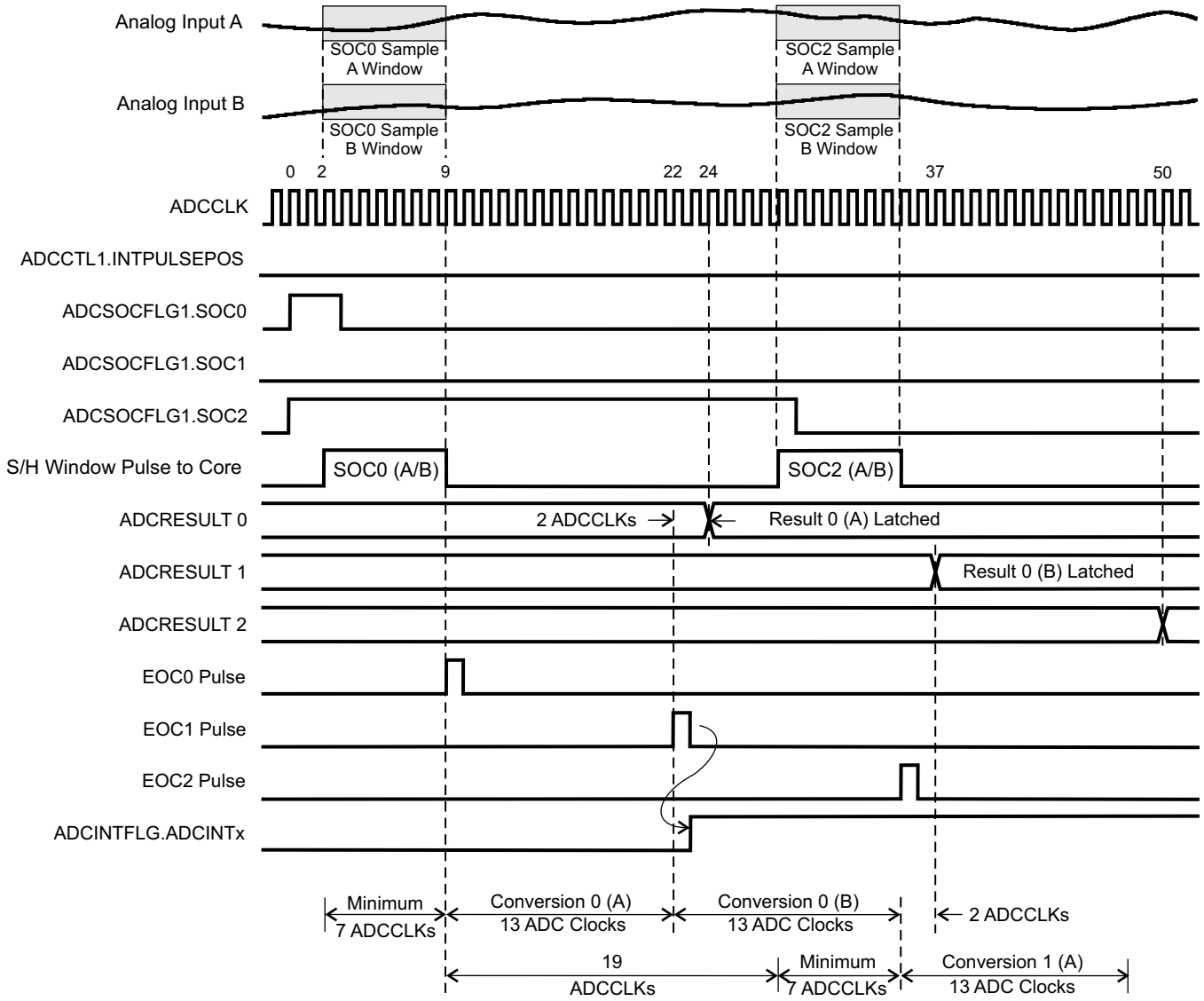
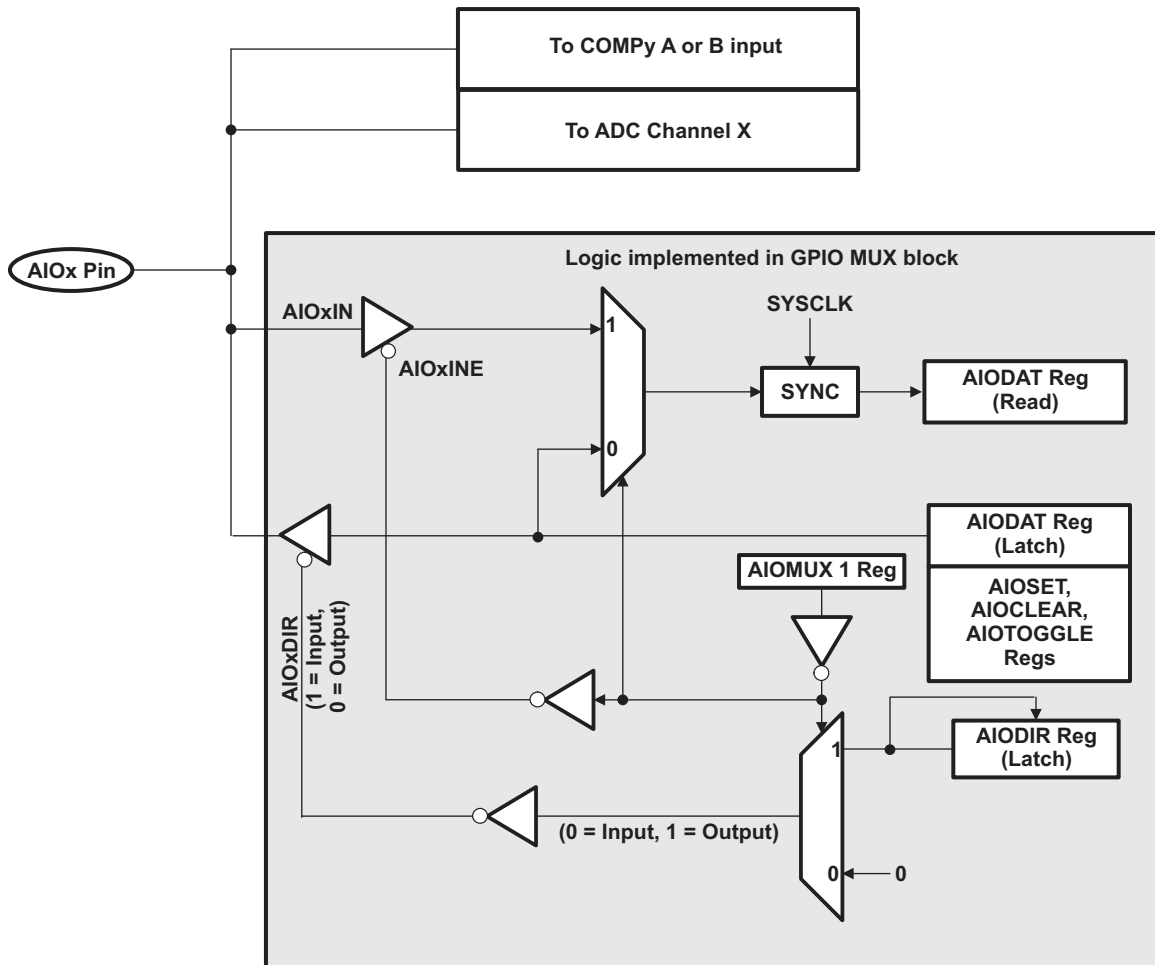

Figure 5-20. Timing Example for Simultaneous Mode / Early Interrupt Pulse

### 5.7.4.1.2 ADC MUX



**Figure 5-21. AIOx Pin Multiplexing**

The ADC channel and Comparator functions are always available. The digital I/O function is available only when the respective bit in the AIOMUX1 register is 0. In this mode, reading the AIODAT register reflects the actual pin state.

The digital I/O function is disabled when the respective bit in the AIOMUX1 register is 1. In this mode, reading the AIODAT register reflects the output latch of the AIODAT register and the input digital I/O buffer is disabled to prevent analog signals from generating noise.

On reset, the digital function is disabled. If the pin is used as an analog input, users should keep the AIO function disabled for that pin.

5.7.4.1.3 Comparator Block

Figure 5-22 shows the interaction of the Comparator modules with the rest of the system.

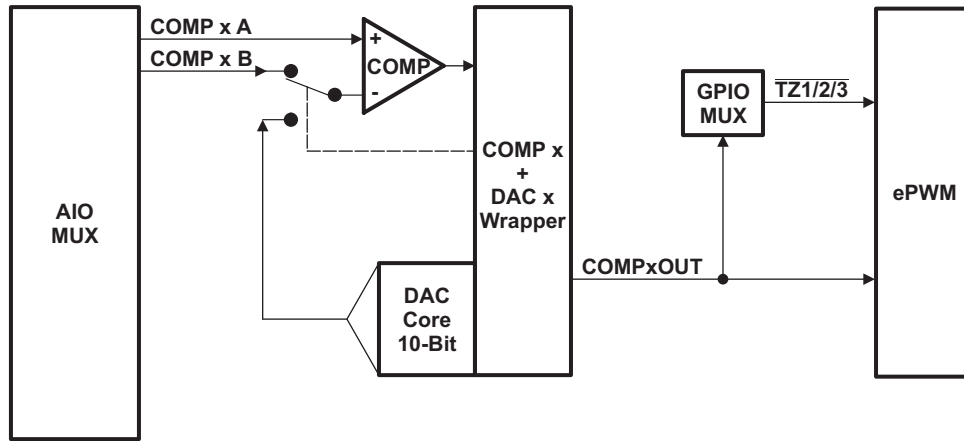

Figure 5-22. Comparator Block Diagram

Table 5-22 lists the Comparator Control Registers.

Table 5-22. Comparator Control Registers

REGISTER NAME	COMP1 ADDRESS	COMP2 ADDRESS	COMP3 ADDRESS	SIZE (x16)	EALLOW PROTECTED	DESCRIPTION
COMPCTL	0x6400	0x6420	0x6440	1	Yes	Comparator Control Register
COMPSTS	0x6402	0x6422	0x6442	1	No	Comparator Status Register
DACCTL	0x6404	0x6424	0x6444	1	Yes	DAC Control Register
DACVAL	0x6406	0x6426	0x6446	1	No	DAC Value Register
RAMPMAXREF_ACTIVE	0x6408	0x6428	0x6448	1	No	Ramp Generator Maximum Reference (Active) Register
RAMPMAXREF_SHDW	0x640A	0x642A	0x644A	1	No	Ramp Generator Maximum Reference (Shadow) Register
RAMPDECVAL_ACTIVE	0x640C	0x642C	0x644C	1	No	Ramp Generator Decrement Value (Active) Register
RAMPDECVAL_SHDW	0x640E	0x642E	0x644E	1	No	Ramp Generator Decrement Value (Shadow) Register
RAMPSTS	0x6410	0x6430	0x6450	1	No	Ramp Generator Status Register

5.7.4.1.3.1 On-Chip Comparator/DAC Electrical Data/Timing

Table 5-23. Electrical Characteristics of the Comparator/DAC

CHARACTERISTIC	MIN	TYP	MAX	UNITS
<b>Comparator</b>				
Comparator Input Range		$V_{SSA} - V_{DDA}$		V
Comparator response time to PWM Trip Zone (Async)		30		ns
Input Offset		$\pm 5$		mV
Input Hysteresis <sup>(1)</sup>		35		mV
<b>DAC</b>				
DAC Output Range		$V_{SSA} - V_{DDA}$		V
DAC resolution		10		bits
DAC settling time		See Figure 5-23		
DAC Gain		-1.5%		
DAC Offset		10		mV
Monotonic		Yes		
INL		$\pm 3$		LSB

(1) Hysteresis on the comparator inputs is achieved with a Schmidt trigger configuration, which results in an effective 100-kΩ feedback resistance between the output of the comparator and the non-inverting input of the comparator.

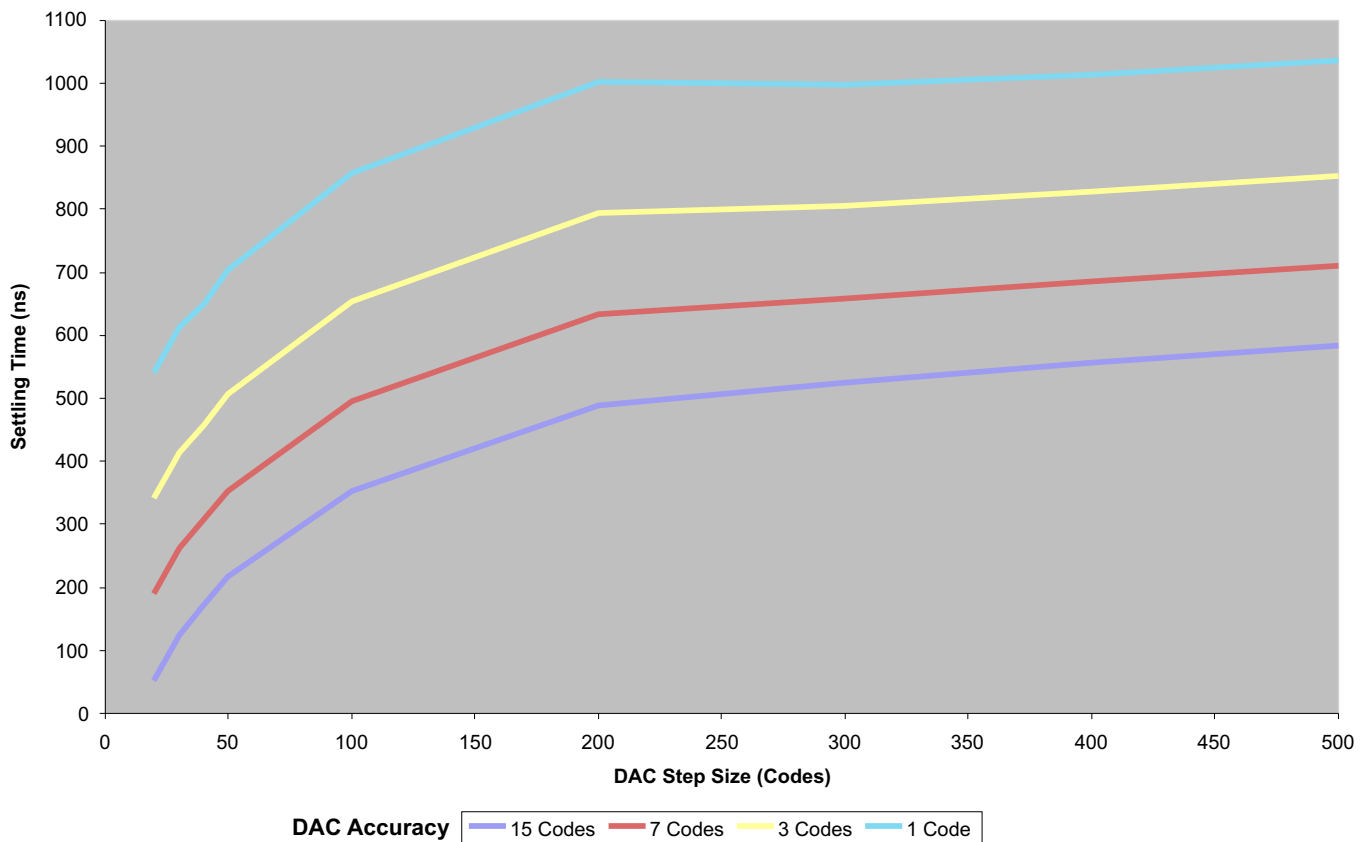

Figure 5-23. DAC Settling Time

## 5.7.4.2 Detailed Descriptions

### Integral Nonlinearity

Integral nonlinearity refers to the deviation of each individual code from a line drawn from zero through full scale. The point used as zero occurs one-half LSB before the first code transition. The full-scale point is defined as level one-half LSB beyond the last code transition. The deviation is measured from the center of each particular code to the true straight line between these two points.

### Differential Nonlinearity

An ideal ADC exhibits code transitions that are exactly 1 LSB apart. DNL is the deviation from this ideal value. A differential nonlinearity error of less than  $\pm 1$  LSB ensures no missing codes.

### Zero Offset

The major carry transition should occur when the analog input is at zero volts. Zero error is defined as the deviation of the actual transition from that point.

### Gain Error

The first code transition should occur at an analog value one-half LSB above negative full scale. The last transition should occur at an analog value one and one-half LSB below the nominal full scale. Gain error is the deviation of the actual difference between first and last code transitions and the ideal difference between first and last code transitions.

### Signal-to-Noise Ratio + Distortion (SINAD)

SINAD is the ratio of the rms value of the measured input signal to the rms sum of all other spectral components below the Nyquist frequency, including harmonics but excluding dc. The value for SINAD is expressed in decibels.

### Effective Number of Bits (ENOB)

For a sine wave, SINAD can be expressed in terms of the number of bits. Using the following formula,  $N = \frac{(\text{SINAD} - 1.76)}{6.02}$  it is possible to get a measure of performance expressed as N, the effective number of bits. Thus, effective number of bits for a device for sine wave inputs at a given input frequency can be calculated directly from its measured SINAD.

### Total Harmonic Distortion (THD)

THD is the ratio of the rms sum of the first nine harmonic components to the rms value of the measured input signal and is expressed as a percentage or in decibels.

### Spurious Free Dynamic Range (SFDR)

SFDR is the difference in dB between the rms amplitude of the input signal and the peak spurious signal.

### 5.7.4.3 Serial Peripheral Interface Module

The device includes the four-pin SPI module. Two SPI modules are available. The SPI is a high-speed, synchronous serial I/O port that allows a serial bit stream of programmed length (one to sixteen bits) to be shifted into and out of the device at a programmable bit-transfer rate. Normally, the SPI is used for communications between the device and external peripherals or another processor. Typical applications include external I/O or peripheral expansion through devices such as shift registers, display drivers, and ADCs. Multidevice communications are supported by the master/slave operation of the SPI.

The SPI module features include:

- Four external pins:
  - SPISOMI: SPI slave-output/master-input pin
  - SPISIMO: SPI slave-input/master-output pin
  - $\overline{\text{SPISTE}}$ : SPI slave transmit-enable pin
  - SPICLK: SPI serial-clock pin

**NOTE:** All four pins can be used as GPIO if the SPI module is not used.

- Two operational modes: master and slave  
Baud rate: 125 different programmable rates.

$$\text{Baud rate} = \frac{\text{LSPCLK}}{(\text{SPIBRR} + 1)} \quad \text{when SPIBRR} = 3 \text{ to } 127$$

$$\text{Baud rate} = \frac{\text{LSPCLK}}{4} \quad \text{when SPIBRR} = 0, 1, 2$$

- Data word length: one to sixteen data bits
- Four clocking schemes (controlled by clock polarity and clock phase bits) include:
  - Falling edge without phase delay: SPICLK active-high. SPI transmits data on the falling edge of the SPICLK signal and receives data on the rising edge of the SPICLK signal.
  - Falling edge with phase delay: SPICLK active-high. SPI transmits data one half-cycle ahead of the falling edge of the SPICLK signal and receives data on the falling edge of the SPICLK signal.
  - Rising edge without phase delay: SPICLK inactive-low. SPI transmits data on the rising edge of the SPICLK signal and receives data on the falling edge of the SPICLK signal.
  - Rising edge with phase delay: SPICLK inactive-low. SPI transmits data one half-cycle ahead of the falling edge of the SPICLK signal and receives data on the rising edge of the SPICLK signal.
- Simultaneous receive and transmit operation (transmit function can be disabled in software)
- Transmitter and receiver operations are accomplished through either interrupt-driven or polled algorithms.
- Nine SPI module control registers: Located in control register frame beginning at address 7040h.

#### NOTE

All registers in this module are 16-bit registers that are connected to Peripheral Frame 2. When a register is accessed, the register data is in the lower byte (7–0), and the upper byte (15–8) is read as zeros. Writing to the upper byte has no effect.

Enhanced feature:

- 4-level transmit/receive FIFO
- Delayed transmit control
- Bi-directional 3 wire SPI mode support
- Audio data receive support via  $\overline{\text{SPISTE}}$  inversion

The SPI port operation is configured and controlled by the registers listed in [Table 5-24](#) and [Table 5-25](#).

**Table 5-24. SPI-A Registers**

NAME	ADDRESS	SIZE (x16)	EALLOW PROTECTED	DESCRIPTION <sup>(1)</sup>
SPICCR	0x7040	1	No	SPI-A Configuration Control Register
SPICTL	0x7041	1	No	SPI-A Operation Control Register
SPISTS	0x7042	1	No	SPI-A Status Register
SPIBRR	0x7044	1	No	SPI-A Baud Rate Register
SPIRXEMU	0x7046	1	No	SPI-A Receive Emulation Buffer Register
SPIRXBUF	0x7047	1	No	SPI-A Serial Input Buffer Register
SPITXBUF	0x7048	1	No	SPI-A Serial Output Buffer Register
SPIDAT	0x7049	1	No	SPI-A Serial Data Register
SPIFFTX	0x704A	1	No	SPI-A FIFO Transmit Register
SPIFFRX	0x704B	1	No	SPI-A FIFO Receive Register
SPIFFCT	0x704C	1	No	SPI-A FIFO Control Register
SPIPRI	0x704F	1	No	SPI-A Priority Control Register

(1) Registers in this table are mapped to Peripheral Frame 2. This space only allows 16-bit accesses. 32-bit accesses produce undefined results.

**Table 5-25. SPI-B Registers**

NAME	ADDRESS	SIZE (x16)	EALLOW PROTECTED	DESCRIPTION <sup>(1)</sup>
SPICCR	0x7740	1	No	SPI-B Configuration Control Register
SPICTL	0x7741	1	No	SPI-B Operation Control Register
SPISTS	0x7742	1	No	SPI-B Status Register
SPIBRR	0x7744	1	No	SPI-B Baud Rate Register
SPIRXEMU	0x7746	1	No	SPI-B Receive Emulation Buffer Register
SPIRXBUF	0x7747	1	No	SPI-B Serial Input Buffer Register
SPITXBUF	0x7748	1	No	SPI-B Serial Output Buffer Register
SPIDAT	0x7749	1	No	SPI-B Serial Data Register
SPIFFTX	0x774A	1	No	SPI-B FIFO Transmit Register
SPIFFRX	0x774B	1	No	SPI-B FIFO Receive Register
SPIFFCT	0x774C	1	No	SPI-B FIFO Control Register
SPIPRI	0x774F	1	No	SPI-B Priority Control Register

(1) Registers in this table are mapped to Peripheral Frame 2. This space only allows 16-bit accesses. 32-bit accesses produce undefined results.

Figure 5-24 is a block diagram of the SPI in slave mode.

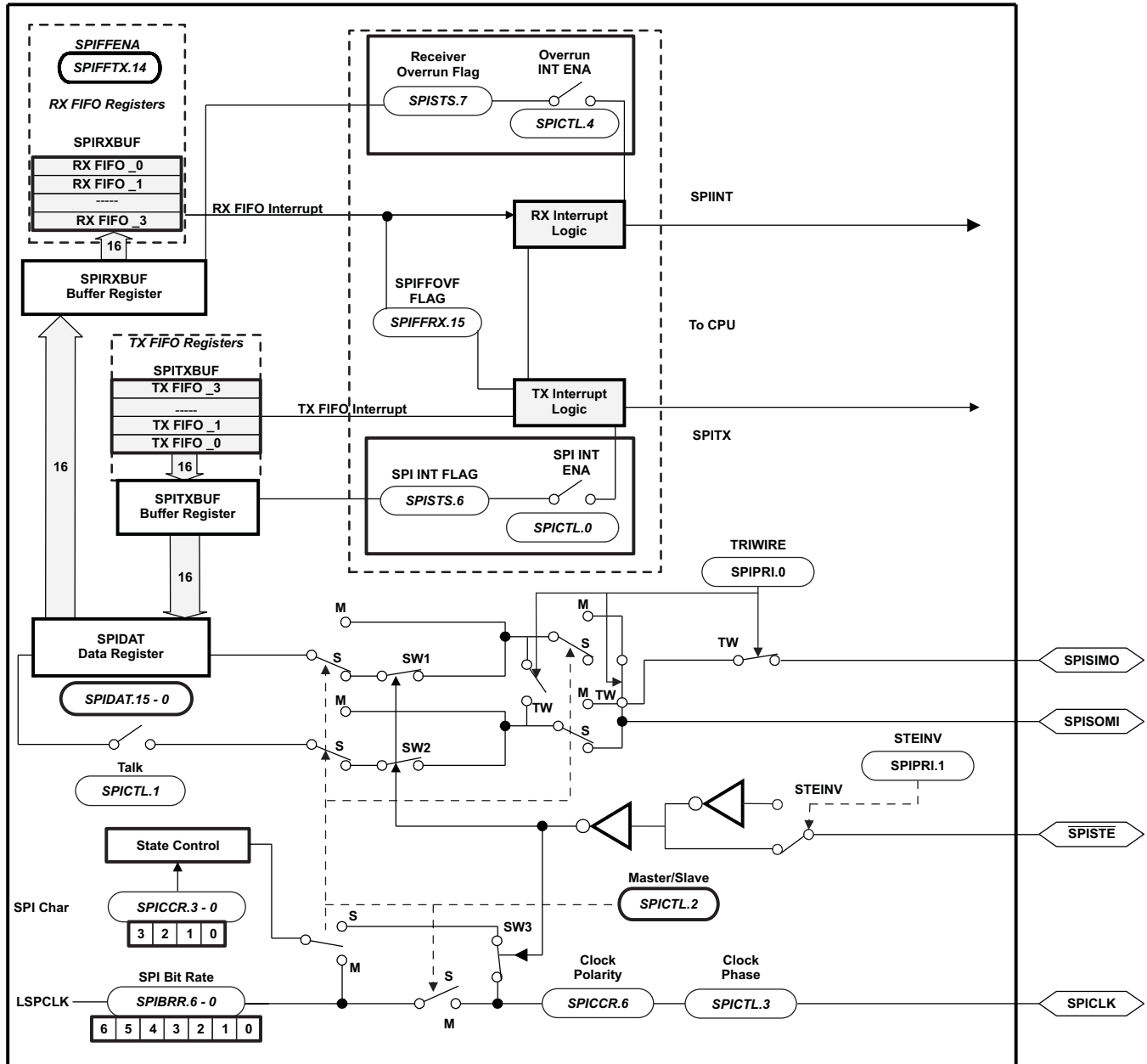

A.  $\overline{\text{SPISTE}}$  is driven low by the master for a slave device.

Figure 5-24. SPI Module Block Diagram (Slave Mode)

**5.7.4.3.1 SPI Master Mode Electrical Data/Timing**

Table 5-26 lists the master mode timing (clock phase = 0) and Table 5-27 lists the master mode timing (clock phase = 1). Figure 5-25 and Figure 5-26 show the timing waveforms.

**Table 5-26. SPI Master Mode External Timing (Clock Phase = 0)<sup>(1)(2)(3)(4)(5)</sup>**

NO.			SPI WHEN (SPIBRR + 1) IS EVEN OR SPIBRR = 0 OR 2		SPI WHEN (SPIBRR + 1) IS ODD AND SPIBRR > 3		UNIT
			MIN	MAX	MIN	MAX	
1	$t_{c(SPC)M}$	Cycle time, SPICLK	$4t_{c(LCO)}$	$128t_{c(LCO)}$	$5t_{c(LCO)}$	$127t_{c(LCO)}$	ns
2	$t_{w(SPCH)M}$	Pulse duration, SPICLK high (clock polarity = 0)	$0.5t_{c(SPC)M} - 10$	$0.5t_{c(SPC)M}$	$0.5t_{c(SPC)M} - 0.5t_{c(LCO)} - 10$	$0.5t_{c(SPC)M} - 0.5t_{c(LCO)}$	ns
	$t_{w(SPCL)M}$	Pulse duration, SPICLK low (clock polarity = 1)	$0.5t_{c(SPC)M} - 10$	$0.5t_{c(SPC)M}$	$0.5t_{c(SPC)M} - 0.5t_{c(LCO)} - 10$	$0.5t_{c(SPC)M} - 0.5t_{c(LCO)}$	
3	$t_{w(SPCL)M}$	Pulse duration, SPICLK low (clock polarity = 0)	$0.5t_{c(SPC)M} - 10$	$0.5t_{c(SPC)M}$	$0.5t_{c(SPC)M} + 0.5t_{c(LCO)} - 10$	$0.5t_{c(SPC)M} + 0.5t_{c(LCO)}$	ns
	$t_{w(SPCH)M}$	Pulse duration, SPICLK high (clock polarity = 1)	$0.5t_{c(SPC)M} - 10$	$0.5t_{c(SPC)M}$	$0.5t_{c(SPC)M} + 0.5t_{c(LCO)} - 10$	$0.5t_{c(SPC)M} + 0.5t_{c(LCO)}$	
4	$t_{d(SPCH-SIMO)M}$	Delay time, SPICLK high to SPISIMO valid (clock polarity = 0)		10		10	ns
	$t_{d(SPCL-SIMO)M}$	Delay time, SPICLK low to SPISIMO valid (clock polarity = 1)		10		10	
5	$t_{v(SPCL-SIMO)M}$	Valid time, SPISIMO data valid after SPICLK low (clock polarity = 0)	$0.5t_{c(SPC)M} - 10$		$0.5t_{c(SPC)M} + 0.5t_{c(LCO)} - 10$		ns
	$t_{v(SPCH-SIMO)M}$	Valid time, SPISIMO data valid after SPICLK high (clock polarity = 1)	$0.5t_{c(SPC)M} - 10$		$0.5t_{c(SPC)M} + 0.5t_{c(LCO)} - 10$		
8	$t_{su(SOMI-SPCL)M}$	Setup time, SPISOMI before SPICLK low (clock polarity = 0)	26		26		ns
	$t_{su(SOMI-SPCH)M}$	Setup time, SPISOMI before SPICLK high (clock polarity = 1)	26		26		
9	$t_{v(SPCL-SOMI)M}$	Valid time, SPISOMI data valid after SPICLK low (clock polarity = 0)	$0.25t_{c(SPC)M} - 10$		$0.5t_{c(SPC)M} - 0.5t_{c(LCO)} - 10$		ns
	$t_{v(SPCH-SOMI)M}$	Valid time, SPISOMI data valid after SPICLK high (clock polarity = 1)	$0.25t_{c(SPC)M} - 10$		$0.5t_{c(SPC)M} - 0.5t_{c(LCO)} - 10$		

(1) The MASTER / SLAVE bit (SPICTL.2) is set and the CLOCK PHASE bit (SPICTL.3) is cleared.

(2)  $t_{c(SPC)}$  = SPI clock cycle time = LSPCLK/4 or LSPCLK/(SPIBRR + 1)

(3)  $t_{c(LCO)}$  = LSPCLK cycle time

(4) Internal clock prescalers must be adjusted such that the SPI clock speed is limited to the following SPI clock rate:

Master mode transmit 20-MHz MAX, master mode receive 10-MHz MAX

Slave mode transmit 10-MHz MAX, slave mode receive 10-MHz MAX.

(5) The active edge of the SPICLK signal referenced is controlled by the clock polarity bit (SPICCR.6).



**Table 5-27. SPI Master Mode External Timing (Clock Phase = 1)<sup>(1)(2)(3)(4)(5)</sup>**

NO.			SPI WHEN (SPIBRR + 1) IS EVEN OR SPIBRR = 0 OR 2		SPI WHEN (SPIBRR + 1) IS ODD AND SPIBRR > 3		UNIT
			MIN	MAX	MIN	MAX	
1	$t_{c(SPC)M}$	Cycle time, SPICLK	$4t_{c(LCO)}$	$128t_{c(LCO)}$	$5t_{c(LCO)}$	$127t_{c(LCO)}$	ns
2	$t_{w(SPCH)M}$	Pulse duration, SPICLK high (clock polarity = 0)	$0.5t_{c(SPC)M} - 10$	$0.5t_{c(SPC)M}$	$0.5t_{c(SPC)M} - 0.5t_{c(LCO)} - 10$	$0.5t_{c(SPC)M} - 0.5t_{c(LCO)}$	ns
	$t_{w(SPCL)M}$	Pulse duration, SPICLK low (clock polarity = 1)	$0.5t_{c(SPC)M} - 10$	$0.5t_{c(SPC)M}$	$0.5t_{c(SPC)M} - 0.5t_{c(LCO)} - 10$	$0.5t_{c(SPC)M} - 0.5t_{c(LCO)}$	
3	$t_{w(SPCL)M}$	Pulse duration, SPICLK low (clock polarity = 0)	$0.5t_{c(SPC)M} - 10$	$0.5t_{c(SPC)M}$	$0.5t_{c(SPC)M} + 0.5t_{c(LCO)} - 10$	$0.5t_{c(SPC)M} + 0.5t_{c(LCO)}$	ns
	$t_{w(SPCH)M}$	Pulse duration, SPICLK high (clock polarity = 1)	$0.5t_{c(SPC)M} - 10$	$0.5t_{c(SPC)M}$	$0.5t_{c(SPC)M} + 0.5t_{c(LCO)} - 10$	$0.5t_{c(SPC)M} + 0.5t_{c(LCO)}$	
6	$t_{su(SIMO-SPCH)M}$	Setup time, SPISIMO data valid before SPICLK high (clock polarity = 0)	$0.5t_{c(SPC)M} - 10$		$0.5t_{c(SPC)M} - 10$		ns
	$t_{su(SIMO-SPCL)M}$	Setup time, SPISIMO data valid before SPICLK low (clock polarity = 1)	$0.5t_{c(SPC)M} - 10$		$0.5t_{c(SPC)M} - 10$		
7	$t_{v(SPCH-SIMO)M}$	Valid time, SPISIMO data valid after SPICLK high (clock polarity = 0)	$0.5t_{c(SPC)M} - 10$		$0.5t_{c(SPC)M} - 10$		ns
	$t_{v(SPCL-SIMO)M}$	Valid time, SPISIMO data valid after SPICLK low (clock polarity = 1)	$0.5t_{c(SPC)M} - 10$		$0.5t_{c(SPC)M} - 10$		
10	$t_{su(SOMI-SPCH)M}$	Setup time, SPISOMI before SPICLK high (clock polarity = 0)	26		26		ns
	$t_{su(SOMI-SPCL)M}$	Setup time, SPISOMI before SPICLK low (clock polarity = 1)	26		26		
11	$t_{v(SPCH-SOMI)M}$	Valid time, SPISOMI data valid after SPICLK high (clock polarity = 0)	$0.25t_{c(SPC)M} - 10$		$0.5t_{c(SPC)M} - 10$		ns
	$t_{v(SPCL-SOMI)M}$	Valid time, SPISOMI data valid after SPICLK low (clock polarity = 1)	$0.25t_{c(SPC)M} - 10$		$0.5t_{c(SPC)M} - 10$		

- (1) The MASTER/SLAVE bit (SPICTL.2) is set and the CLOCK PHASE bit (SPICTL.3) is set.  
 (2)  $t_{c(SPC)}$  = SPI clock cycle time = LSPCLK/4 or LSPCLK/(SPIBRR + 1)  
 (3) Internal clock prescalers must be adjusted such that the SPI clock speed is limited to the following SPI clock rate:  
 Master mode transmit 20-MHz MAX, master mode receive 10-MHz MAX  
 Slave mode transmit 10-MHz MAX, slave mode receive 10-MHz MAX.  
 (4)  $t_{c(LCO)}$  = LSPCLK cycle time  
 (5) The active edge of the SPICLK signal referenced is controlled by the CLOCK POLARITY bit (SPICCR.6).

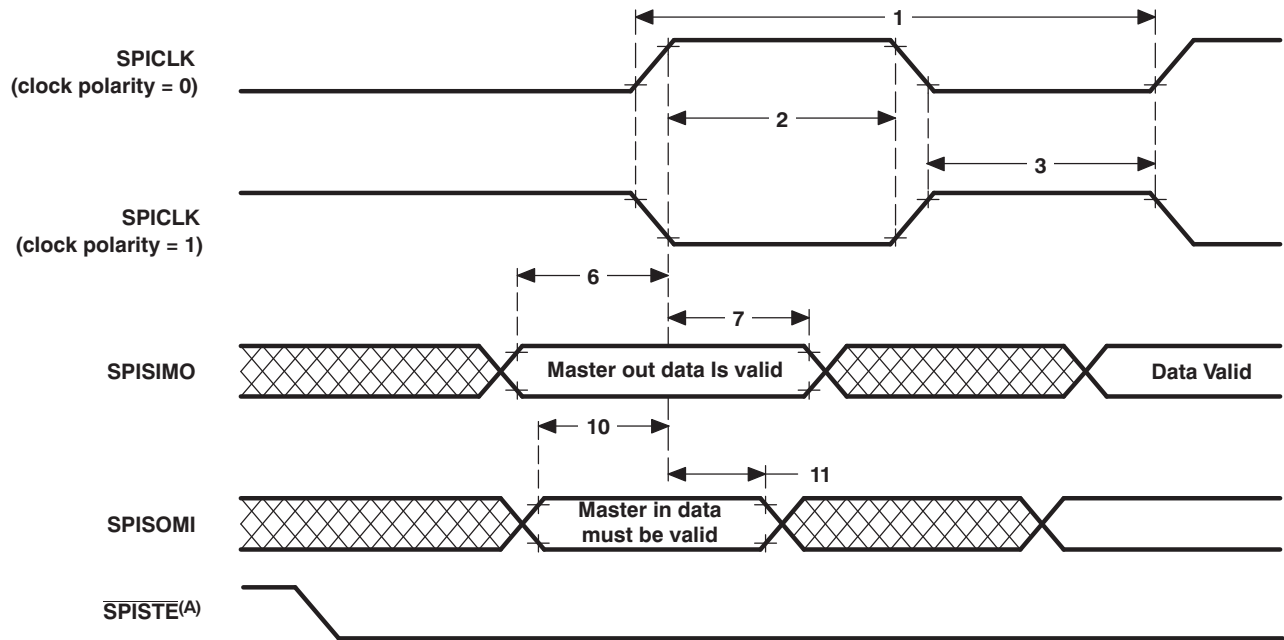

- A. In the master mode,  $\overline{\text{SPISTE}}$  goes active  $0.5t_{c(\text{SPC})}$  (minimum) before valid SPI clock edge. On the trailing end of the word, the  $\overline{\text{SPISTE}}$  will go inactive  $0.5t_{c(\text{SPC})}$  after the receiving edge ( $\text{SPICLK}$ ) of the last data bit, except that  $\overline{\text{SPISTE}}$  stays active between back-to-back transmit words in both FIFO and non-FIFO modes.

**Figure 5-26. SPI Master Mode External Timing (Clock Phase = 1)**

5.7.4.3.2 SPI Slave Mode Electrical Data/Timing

Table 5-28 lists the slave mode external timing (clock phase = 0) and Table 5-29 lists the slave mode external timing (clock phase = 1). Figure 5-27 and Figure 5-28 show the timing waveforms.

Table 5-28. SPI Slave Mode External Timing (Clock Phase = 0)<sup>(1)(2)(3)(4)(5)</sup>

NO.			MIN	MAX	UNIT
12	$t_{c(SPC)S}$	Cycle time, SPICLK	$4t_{c(LCO)}$		ns
13	$t_{w(SPCH)S}$	Pulse duration, SPICLK high (clock polarity = 0)	$0.5t_{c(SPC)S} - 10$	$0.5t_{c(SPC)S}$	ns
	$t_{w(SPCL)S}$	Pulse duration, SPICLK low (clock polarity = 1)	$0.5t_{c(SPC)S} - 10$	$0.5t_{c(SPC)S}$	
14	$t_{w(SPCL)S}$	Pulse duration, SPICLK low (clock polarity = 0)	$0.5t_{c(SPC)S} - 10$	$0.5t_{c(SPC)S}$	ns
	$t_{w(SPCH)S}$	Pulse duration, SPICLK high (clock polarity = 1)	$0.5t_{c(SPC)S} - 10$	$0.5t_{c(SPC)S}$	
15	$t_{d(SPCH-SOMI)S}$	Delay time, SPICLK high to SPISOMI valid (clock polarity = 0)		21	ns
	$t_{d(SPCL-SOMI)S}$	Delay time, SPICLK low to SPISOMI valid (clock polarity = 1)		21	
16	$t_{v(SPCL-SOMI)S}$	Valid time, SPISOMI data valid after SPICLK low (clock polarity = 0)	$0.75t_{c(SPC)S}$		ns
	$t_{v(SPCH-SOMI)S}$	Valid time, SPISOMI data valid after SPICLK high (clock polarity = 1)	$0.75t_{c(SPC)S}$		
19	$t_{su(SIMO-SPCL)S}$	Setup time, SPISIMO before SPICLK low (clock polarity = 0)	26		ns
	$t_{su(SIMO-SPCH)S}$	Setup time, SPISIMO before SPICLK high (clock polarity = 1)	26		
20	$t_{v(SPCL-SIMO)S}$	Valid time, SPISIMO data valid after SPICLK low (clock polarity = 0)	$0.5t_{c(SPC)S} - 10$		ns
	$t_{v(SPCH-SIMO)S}$	Valid time, SPISIMO data valid after SPICLK high (clock polarity = 1)	$0.5t_{c(SPC)S} - 10$		

- (1) The MASTER / SLAVE bit (SPICTL.2) is cleared and the CLOCK PHASE bit (SPICTL.3) is cleared.
- (2)  $t_{c(SPC)} = \text{SPI clock cycle time} = \text{LSPCLK}/4$  or  $\text{LSPCLK}/(\text{SPIBRR} + 1)$
- (3) Internal clock prescalers must be adjusted such that the SPI clock speed is limited to the following SPI clock rate:  
Master mode transmit 20-MHz MAX, master mode receive 10-MHz MAX  
Slave mode transmit 10-MHz MAX, slave mode receive 10-MHz MAX.
- (4)  $t_{c(LCO)} = \text{LSPCLK cycle time}$
- (5) The active edge of the SPICLK signal referenced is controlled by the CLOCK POLARITY bit (SPICCR.6).

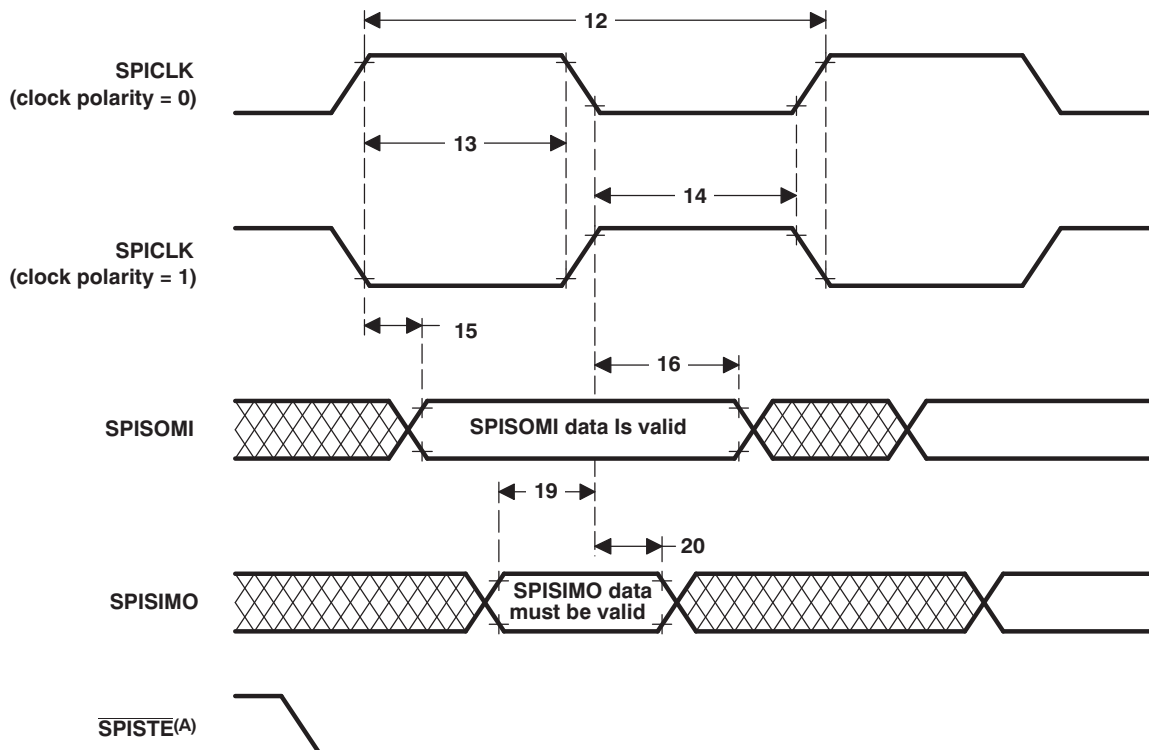

- A. In the slave mode, the SPISTE signal should be asserted low at least  $0.5t_{c(SPC)}$  (minimum) before the valid SPI clock edge and remain low for at least  $0.5t_{c(SPC)}$  after the receiving edge (SPICLK) of the last data bit.

Figure 5-27. SPI Slave Mode External Timing (Clock Phase = 0)

**Table 5-29. SPI Slave Mode External Timing (Clock Phase = 1)<sup>(1)(2)(3)(4)(5)</sup>**

NO.			MIN	MAX	UNIT
12	$t_{c(SPC)S}$	Cycle time, SPICLK	$8t_{c(LCO)}$		ns
13	$t_{w(SPCH)S}$	Pulse duration, SPICLK high (clock polarity = 0)	$0.5t_{c(SPC)S} - 10$	$0.5t_{c(SPC)S}$	ns
	$t_{w(SPCL)S}$	Pulse duration, SPICLK low (clock polarity = 1)	$0.5t_{c(SPC)S} - 10$	$0.5t_{c(SPC)S}$	
14	$t_{w(SPCL)S}$	Pulse duration, SPICLK low (clock polarity = 0)	$0.5t_{c(SPC)S} - 10$	$0.5t_{c(SPC)S}$	ns
	$t_{w(SPCH)S}$	Pulse duration, SPICLK high (clock polarity = 1)	$0.5t_{c(SPC)S} - 10$	$0.5t_{c(SPC)S}$	
17	$t_{su(SOMI-SPCH)S}$	Setup time, SPISOMI before SPICLK high (clock polarity = 0)	$0.125t_{c(SPC)S}$		ns
	$t_{su(SOMI-SPCL)S}$	Setup time, SPISOMI before SPICLK low (clock polarity = 1)	$0.125t_{c(SPC)S}$		
18	$t_{v(SPCL-SOMI)S}$	Valid time, SPISOMI data valid after SPICLK low (clock polarity = 1)	$0.75t_{c(SPC)S}$		ns
	$t_{v(SPCH-SOMI)S}$	Valid time, SPISOMI data valid after SPICLK high (clock polarity = 0)	$0.75t_{c(SPC)S}$		
21	$t_{su(SIMO-SPCH)S}$	Setup time, SPISIMO before SPICLK high (clock polarity = 0)	26		ns
	$t_{su(SIMO-SPCL)S}$	Setup time, SPISIMO before SPICLK low (clock polarity = 1)	26		
22	$t_{v(SPCH-SIMO)S}$	Valid time, SPISIMO data valid after SPICLK high (clock polarity = 0)	$0.5t_{c(SPC)S} - 10$		ns
	$t_{v(SPCL-SIMO)S}$	Valid time, SPISIMO data valid after SPICLK low (clock polarity = 1)	$0.5t_{c(SPC)S} - 10$		

- (1) The MASTER / SLAVE bit (SPICTL.2) is cleared and the CLOCK PHASE bit (SPICTL.3) is cleared.
- (2)  $t_{c(SPC)}$  = SPI clock cycle time = LSPCLK/4 or LSPCLK/(SPIBRR + 1)
- (3)  $t_{c(LCO)}$  = LSPCLK cycle time
- (4) Internal clock prescalers must be adjusted such that the SPI clock speed is limited to the following SPI clock rate:  
 Master mode transmit 20-MHz MAX, master mode receive 10-MHz MAX  
 Slave mode transmit 10-MHz MAX, slave mode receive 10-MHz MAX.
- (5) The active edge of the SPICLK signal referenced is controlled by the CLOCK POLARITY bit (SPICCR.6).

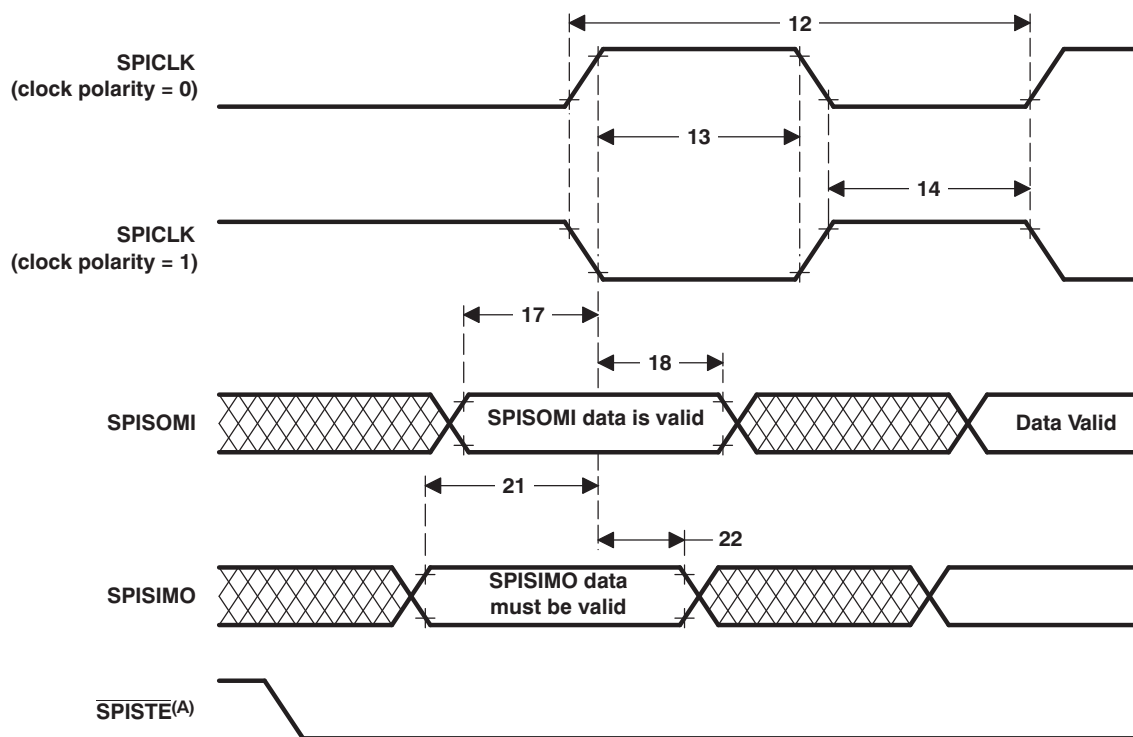

A. In the slave mode, the  $\overline{SPISTE}$  signal should be asserted low at least  $0.5t_{c(SPC)}$  before the valid SPI clock edge and remain low for at least  $0.5t_{c(SPC)}$  after the receiving edge (SPICLK) of the last data bit.

**Figure 5-28. SPI Slave Mode External Timing (Clock Phase = 1)**

#### 5.7.4.4 Serial Communications Interface

The F28PLC8x device includes two SCI modules (SCI-A, SCI-B). The SCI module supports digital communications between the CPU and other asynchronous peripherals that use the standard non-return-to-zero (NRZ) format. The SCI receiver and transmitter are double-buffered, and each has its own separate enable and interrupt bits. Both can be operated independently or simultaneously in the full-duplex mode. To ensure data integrity, the SCI checks received data for break detection, parity, overrun, and framing errors. The bit rate is programmable to over 65000 different speeds through a 16-bit baud-select register.

Features of each SCI module include:

- Two external pins:
    - SCITXD: SCI transmit-output pin
    - SCIRXD: SCI receive-input pin
- NOTE:** Both pins can be used as GPIO if not used for SCI.
- Baud rate programmable to 64K different rates:

$$\text{Baud rate} = \frac{\text{LSPCLK}}{(\text{BRR} + 1) * 8} \quad \text{when BRR} \neq 0$$

$$\text{Baud rate} = \frac{\text{LSPCLK}}{16} \quad \text{when BRR} = 0$$

- Data-word format
  - One start bit
  - Data-word length programmable from one to eight bits
  - Optional even/odd/no parity bit
  - One or two stop bits
- Four error-detection flags: parity, overrun, framing, and break detection
- Two wake-up multiprocessor modes: idle-line and address bit
- Half- or full-duplex operation
- Double-buffered receive and transmit functions
- Transmitter and receiver operations can be accomplished through interrupt-driven or polled algorithms with status flags.
  - Transmitter: TXRDY flag (transmitter-buffer register is ready to receive another character) and TX EMPTY flag (transmitter-shift register is empty)
  - Receiver: RXRDY flag (receiver-buffer register is ready to receive another character), BRKDT flag (break condition occurred), and RX ERROR flag (monitoring four interrupt conditions)
- Separate enable bits for transmitter and receiver interrupts (except BRKDT)
- NRZ (non-return-to-zero) format

---

#### NOTE

All registers in this module are 8-bit registers that are connected to Peripheral Frame 2. When a register is accessed, the register data is in the lower byte (7–0), and the upper byte (15–8) is read as zeros. Writing to the upper byte has no effect.

---

Enhanced features:

- Auto baud-detect hardware logic
- 4-level transmit/receive FIFO

The SCI port operation is configured and controlled by the registers listed in [Table 5-30](#) and [Table 5-31](#).

**Table 5-30. SCI-A Registers<sup>(1)</sup>**

NAME	ADDRESS	SIZE (x16)	EALLOW PROTECTED	DESCRIPTION
SCICCRA	0x7050	1	No	SCI-A Communications Control Register
SCICTL1A	0x7051	1	No	SCI-A Control Register 1
SCIHBAUDA	0x7052	1	No	SCI-A Baud Register, High Bits
SCILBAUDA	0x7053	1	No	SCI-A Baud Register, Low Bits
SCICTL2A	0x7054	1	No	SCI-A Control Register 2
SCIRXSTA	0x7055	1	No	SCI-A Receive Status Register
SCIRXEMUA	0x7056	1	No	SCI-A Receive Emulation Data Buffer Register
SCIRXBUFA	0x7057	1	No	SCI-A Receive Data Buffer Register
SCITXBUFA	0x7059	1	No	SCI-A Transmit Data Buffer Register
SCIFFTXA <sup>(2)</sup>	0x705A	1	No	SCI-A FIFO Transmit Register
SCIFFRXA <sup>(2)</sup>	0x705B	1	No	SCI-A FIFO Receive Register
SCIFFCTA <sup>(2)</sup>	0x705C	1	No	SCI-A FIFO Control Register
SCIPRIA	0x705F	1	No	SCI-A Priority Control Register

(1) Registers in this table are mapped to Peripheral Frame 2 space. This space only allows 16-bit accesses. 32-bit accesses produce undefined results.

(2) These registers are new registers for the FIFO mode.

**Table 5-31. SCI-B Registers<sup>(1)</sup>**

NAME	ADDRESS	SIZE (x16)	DESCRIPTION
SCICCRB	0x7750	1	SCI-B Communications Control Register
SCICTL1B	0x7751	1	SCI-B Control Register 1
SCIHBAUDB	0x7752	1	SCI-B Baud Register, High Bits
SCILBAUDB	0x7753	1	SCI-B Baud Register, Low Bits
SCICTL2B	0x7754	1	SCI-B Control Register 2
SCIRXSTB	0x7755	1	SCI-B Receive Status Register
SCIRXEMUB	0x7756	1	SCI-B Receive Emulation Data Buffer Register
SCIRXBUFB	0x7757	1	SCI-B Receive Data Buffer Register
SCITXBUFB	0x7759	1	SCI-B Transmit Data Buffer Register
SCIFFTXB <sup>(2)</sup>	0x775A	1	SCI-B FIFO Transmit Register
SCIFFRXB <sup>(2)</sup>	0x775B	1	SCI-B FIFO Receive Register
SCIFFCTB <sup>(2)</sup>	0x775C	1	SCI-B FIFO Control Register
SCIPRIB	0x775F	1	SCI-B Priority Control Register

(1) Registers in this table are mapped to Peripheral Frame 2 space. This space only allows 16-bit accesses. 32-bit accesses produce undefined results.

(2) These registers are new registers for the FIFO mode.

Figure 5-29 shows the SCI module block diagram.

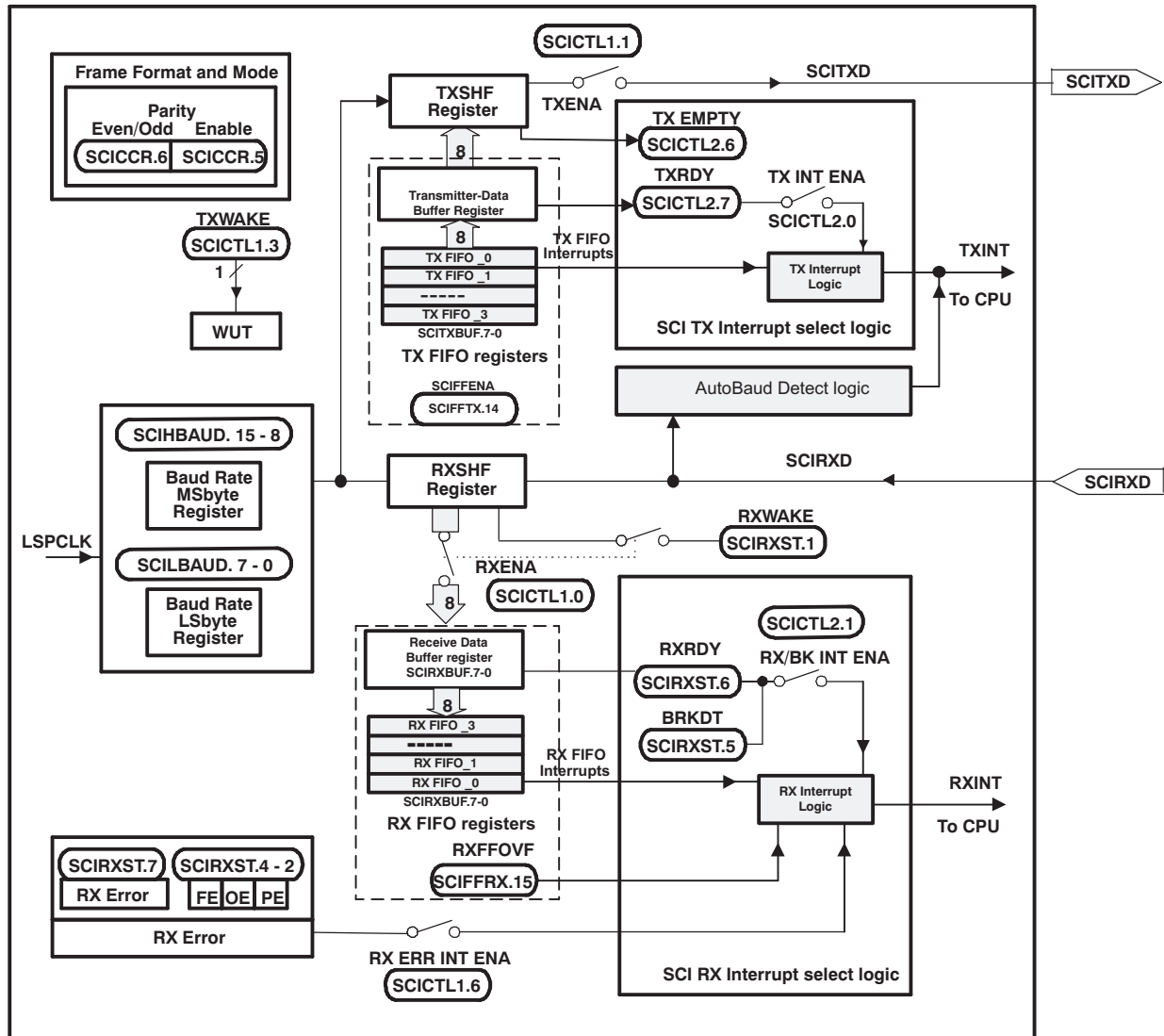

Figure 5-29. SCI Module Block Diagram

#### 5.7.4.5 Multichannel Buffered Serial Port Module

The McBSP module has the following features:

- Compatible to McBSP in TMS320C28x/TMS320F28x devices
- Full-duplex communications
- Double-buffered data registers that allow a continuous data stream
- Independent framing and clocking for receive and transmit
- External shift clock generation or an internal programmable frequency shift clock
- A wide selection of data sizes including 8-, 12-, 16-, 20-, 24-, or 32-bits
- 8-bit data transfers with LSB or MSB first
- Programmable polarity for both frame synchronization and data clocks
- Highly programmable internal clock and frame generation
- Direct interface to industry-standard CODECs, Analog Interface Chips (AICs), and other serially connected analog-to-digital (A/D) and digital-to-analog (D/A) devices
- Works with SPI-compatible devices
- The following application interfaces can be supported on the McBSP:
  - T1/E1 framers
  - IOM-2 compliant devices
  - AC97-compliant devices (the necessary multiphase frame synchronization capability is provided.)
  - IIS-compliant devices
  - SPI
- McBSP clock rate,

$$\text{CLKG} = \frac{\text{CLKSRG}}{(1 + \text{CLKGDV})}$$

where CLKSRG source could be LSPCLK, CLKX, or CLKR. Serial port performance is limited by I/O buffer switching speed. Internal prescalers must be adjusted such that the peripheral speed is less than the I/O buffer speed limit.

---

#### NOTE

See [Table 5-57](#) for maximum I/O pin toggling speed.

---

#### NOTE

On the 80-pin packages, only the clock-stop mode (SPI) of the McBSP is supported.

---

Figure 5-30 shows the block diagram of the McBSP module.

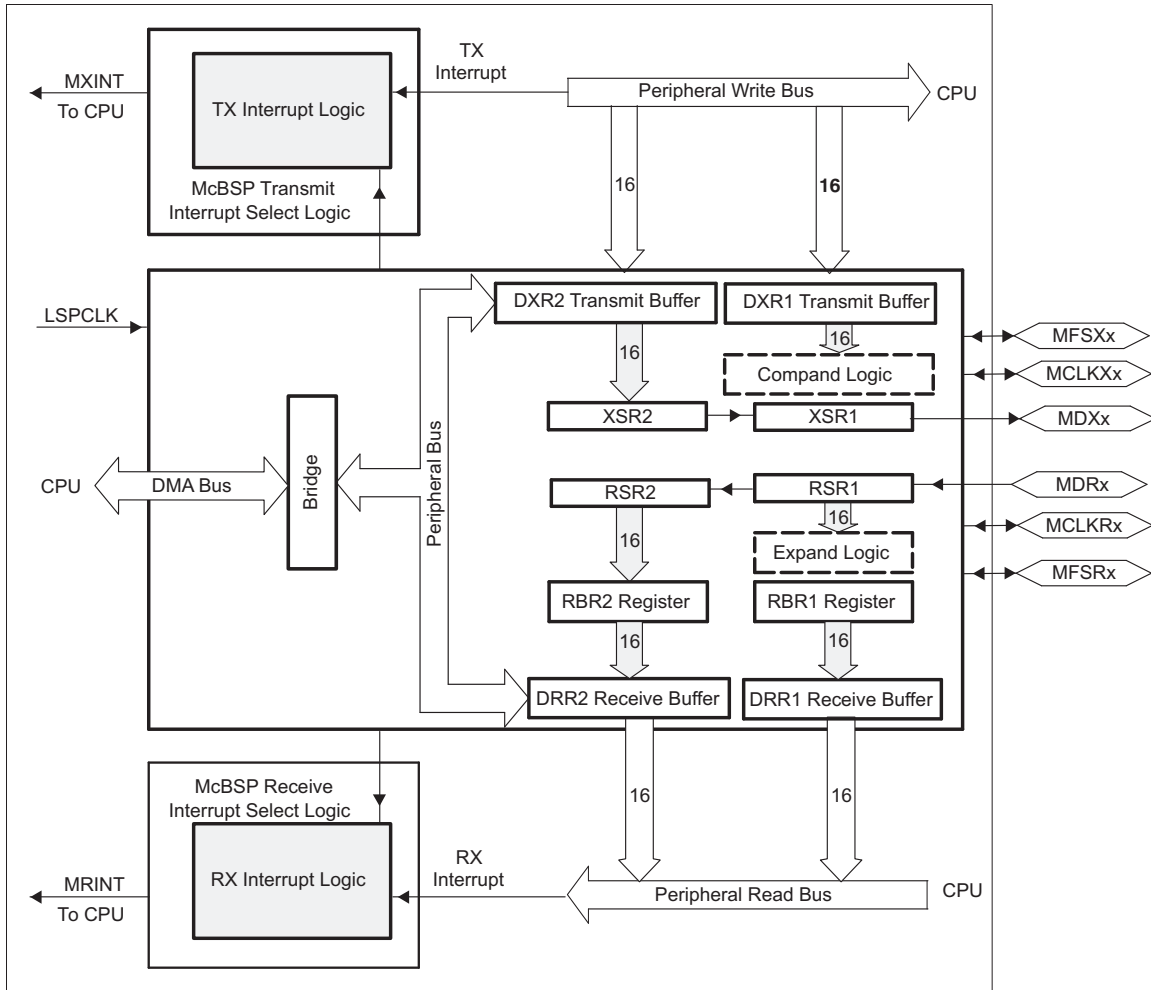

Figure 5-30. McBSP Module

Table 5-32 provides a summary of the McBSP registers.

**Table 5-32. McBSP Register Summary**

NAME	McBSP-A ADDRESS	TYPE	RESET VALUE	DESCRIPTION
<b>Data Registers, Receive, Transmit</b>				
DRR2	0x5000	R	0x0000	McBSP Data Receive Register 2
DRR1	0x5001	R	0x0000	McBSP Data Receive Register 1
DXR2	0x5002	W	0x0000	McBSP Data Transmit Register 2
DXR1	0x5003	W	0x0000	McBSP Data Transmit Register 1
<b>McBSP Control Registers</b>				
SPCR2	0x5004	R/W	0x0000	McBSP Serial Port Control Register 2
SPCR1	0x5005	R/W	0x0000	McBSP Serial Port Control Register 1
RCR2	0x5006	R/W	0x0000	McBSP Receive Control Register 2
RCR1	0x5007	R/W	0x0000	McBSP Receive Control Register 1
XCR2	0x5008	R/W	0x0000	McBSP Transmit Control Register 2
XCR1	0x5009	R/W	0x0000	McBSP Transmit Control Register 1
SRGR2	0x500A	R/W	0x0000	McBSP Sample Rate Generator Register 2
SRGR1	0x500B	R/W	0x0000	McBSP Sample Rate Generator Register 1
<b>Multichannel Control Registers</b>				
MCR2	0x500C	R/W	0x0000	McBSP Multichannel Register 2
MCR1	0x500D	R/W	0x0000	McBSP Multichannel Register 1
RCERA	0x500E	R/W	0x0000	McBSP Receive Channel Enable Register Partition A
RCERB	0x500F	R/W	0x0000	McBSP Receive Channel Enable Register Partition B
XCERA	0x5010	R/W	0x0000	McBSP Transmit Channel Enable Register Partition A
XCERB	0x5011	R/W	0x0000	McBSP Transmit Channel Enable Register Partition B
PCR	0x5012	R/W	0x0000	McBSP Pin Control Register
RCERC	0x5013	R/W	0x0000	McBSP Receive Channel Enable Register Partition C
RCERD	0x5014	R/W	0x0000	McBSP Receive Channel Enable Register Partition D
XCERC	0x5015	R/W	0x0000	McBSP Transmit Channel Enable Register Partition C
XCERD	0x5016	R/W	0x0000	McBSP Transmit Channel Enable Register Partition D
RCERE	0x5017	R/W	0x0000	McBSP Receive Channel Enable Register Partition E
RCERF	0x5018	R/W	0x0000	McBSP Receive Channel Enable Register Partition F
XCERE	0x5019	R/W	0x0000	McBSP Transmit Channel Enable Register Partition E
XCERF	0x501A	R/W	0x0000	McBSP Transmit Channel Enable Register Partition F
RCERG	0x501B	R/W	0x0000	McBSP Receive Channel Enable Register Partition G
RCERH	0x501C	R/W	0x0000	McBSP Receive Channel Enable Register Partition H
XCERG	0x501D	R/W	0x0000	McBSP Transmit Channel Enable Register Partition G
XCERH	0x501E	R/W	0x0000	McBSP Transmit Channel Enable Register Partition H
MFFINT	0x5023	R/W	0x0000	McBSP Interrupt Enable Register

### 5.7.4.5.1 McBSP Electrical Data/Timing

#### 5.7.4.5.1.1 McBSP Transmit and Receive Timing

**Table 5-33. McBSP Timing Requirements<sup>(1)(2)</sup>**

NO.				MIN	MAX	UNIT
	McBSP module clock (CLKG, CLKX, CLKR) range			1		kHz
					20 <sup>(3)(4)</sup>	MHz
	McBSP module cycle time (CLKG, CLKX, CLKR) range			50 <sup>(4)</sup>		ns
					1	ms
M11	$t_{c(\text{CKRX})}$	Cycle time, CLKR/X	CLKR/X ext	2P		ns
M12	$t_{w(\text{CKRX})}$	Pulse duration, CLKR/X high or CLKR/X low	CLKR/X ext	P – 7		ns
M13	$t_{r(\text{CKRX})}$	Rise time, CLKR/X	CLKR/X ext		7	ns
M14	$t_{f(\text{CKRX})}$	Fall time, CLKR/X	CLKR/X ext		7	ns
M15	$t_{su(\text{FRH-CKRL})}$	Setup time, external FSR high before CLKR low	CLKR int	18		ns
			CLKR ext	2		
M16	$t_{h(\text{CKRL-FRH})}$	Hold time, external FSR high after CLKR low	CLKR int	0		ns
			CLKR ext	6		
M17	$t_{su(\text{DRV-CKRL})}$	Setup time, DR valid before CLKR low	CLKR int	18		ns
			CLKR ext	2		
M18	$t_{h(\text{CKRL-DRV})}$	Hold time, DR valid after CLKR low	CLKR int	0		ns
			CLKR ext	6		
M19	$t_{su(\text{FXH-CKXL})}$	Setup time, external FSX high before CLKX low	CLKX int	18		ns
			CLKX ext	2		
M20	$t_{h(\text{CKXL-FXH})}$	Hold time, external FSX high after CLKX low	CLKX int	0		ns
			CLKX ext	6		

- (1) Polarity bits CLKRP = CLKXP = FSRP = FSXP = 0. If the polarity of any of the signals is inverted, then the timing references of that signal are also inverted.
- (2)  $2P = 1/\text{CLKG}$  in ns. CLKG is the output of sample rate generator mux.  $\text{CLKG} = \text{CLKSRG}/(1 + \text{CLKGDV})$ . CLKSRG can be LSPCLK, CLKX, CLKR as source.  $\text{CLKSRG} \leq (\text{SYSCLKOUT}/2)$ . McBSP performance is limited by I/O buffer switching speed.
- (3) Internal clock prescalers must be adjusted such that the McBSP clock (CLKG, CLKX, CLKR) speeds are not greater than the I/O buffer speed limit (20 MHz).
- (4) Maximum McBSP module clock frequency decreases to 10 MHz for internal CLKR.

**Table 5-34. McBSP Switching Characteristics<sup>(1)(2)</sup>**

over recommended operating conditions (unless otherwise noted)

NO.	PARAMETER		MIN	MAX	UNIT		
M1	$t_{c(CKRX)}$	Cycle time, CLKR/X	CLKR/X int	2P	ns		
M2	$t_{w(CKRXH)}$	Pulse duration, CLKR/X high	CLKR/X int	D – 5 <sup>(3)</sup> D + 5 <sup>(3)</sup>	ns		
M3	$t_{w(CKRXL)}$	Pulse duration, CLKR/X low	CLKR/X int	C – 5 <sup>(3)</sup> C + 5 <sup>(3)</sup>	ns		
M4	$t_{d(CKRH-FRV)}$	Delay time, CLKR high to internal FSR valid	CLKR int	0	4	ns	
			CLKR ext	3	27		
M5	$t_{d(CKXH-FXV)}$	Delay time, CLKX high to internal FSX valid	CLKX int	0	4	ns	
			CLKX ext	3	27		
M6	$t_{dis(CKXH-DXHZ)}$	Disable time, CLKX high to DX high impedance following last data bit	CLKX int		8	ns	
			CLKX ext		14		
M7	$t_{d(CKXH-DXV)}$	Delay time, CLKX high to DX valid.	CLKX int		9	ns	
		This applies to all bits except the first bit transmitted.		CLKX ext			28
		Delay time, CLKX high to DX valid	DXENA = 0	CLKX int			8
				CLKX ext			14
Only applies to first bit transmitted when in Data Delay 1 or 2 (XDATDLY=01b or 10b) modes	DXENA = 1	CLKX int		P + 8			
		CLKX ext		P + 14			
M8	$t_{en(CKXH-DX)}$	Enable time, CLKX high to DX driven	DXENA = 0	CLKX int	0	ns	
				CLKX ext	6		
		Only applies to first bit transmitted when in Data Delay 1 or 2 (XDATDLY=01b or 10b) modes	DXENA = 1	CLKX int			P
				CLKX ext			P + 6
M9	$t_{d(FXH-DXV)}$	Delay time, FSX high to DX valid	DXENA = 0	FSX int		8	ns
				FSX ext		14	
		Only applies to first bit transmitted when in Data Delay 0 (XDATDLY=00b) mode.	DXENA = 1	FSX int		P + 8	
				FSX ext		P + 14	
M10	$t_{en(FXH-DX)}$	Enable time, FSX high to DX driven	DXENA = 0	FSX int	0	ns	
				FSX ext	6		
		Only applies to first bit transmitted when in Data Delay 0 (XDATDLY=00b) mode	DXENA = 1	FSX int			P
				FSX ext			P + 6

(1) Polarity bits CLKRP = CLKXP = FSRP = FSXP = 0. If the polarity of any of the signals is inverted, then the timing references of that signal are also inverted.

(2) 2P = 1/CLKG in ns.

(3) C = CLKRX low pulse width = P

D = CLKRX high pulse width = P

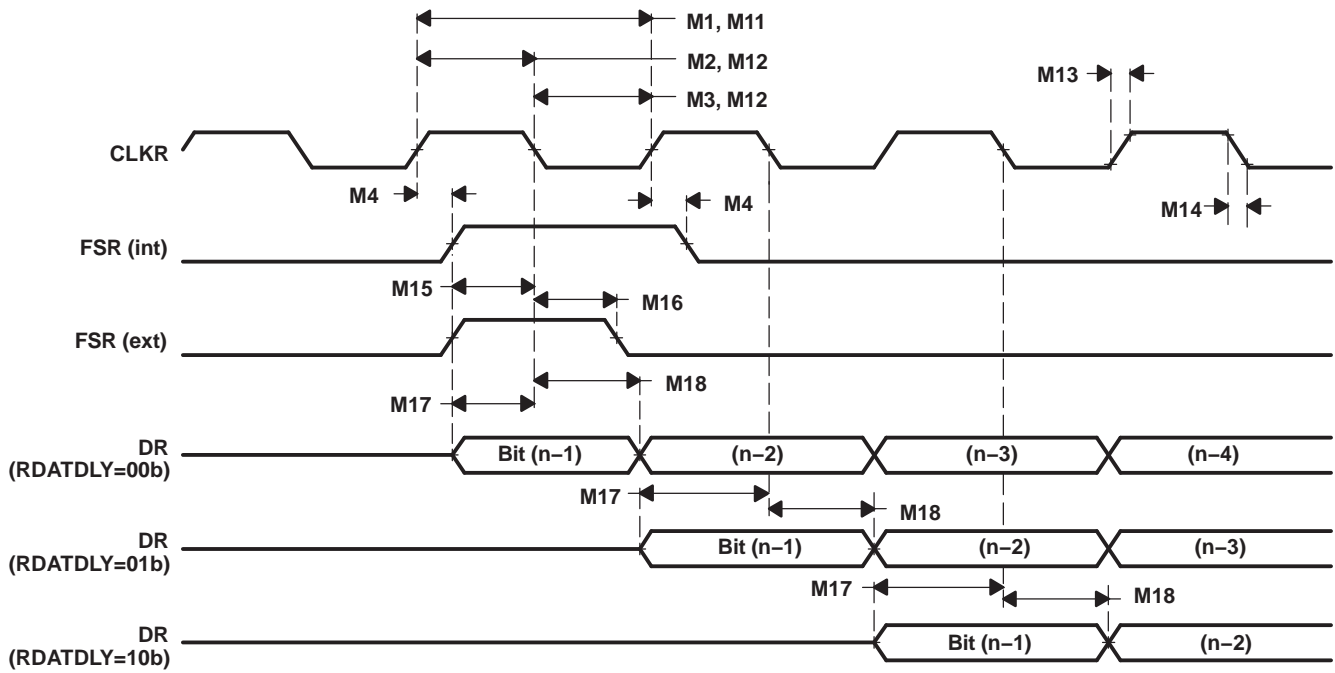

Figure 5-31. McBSP Receive Timing

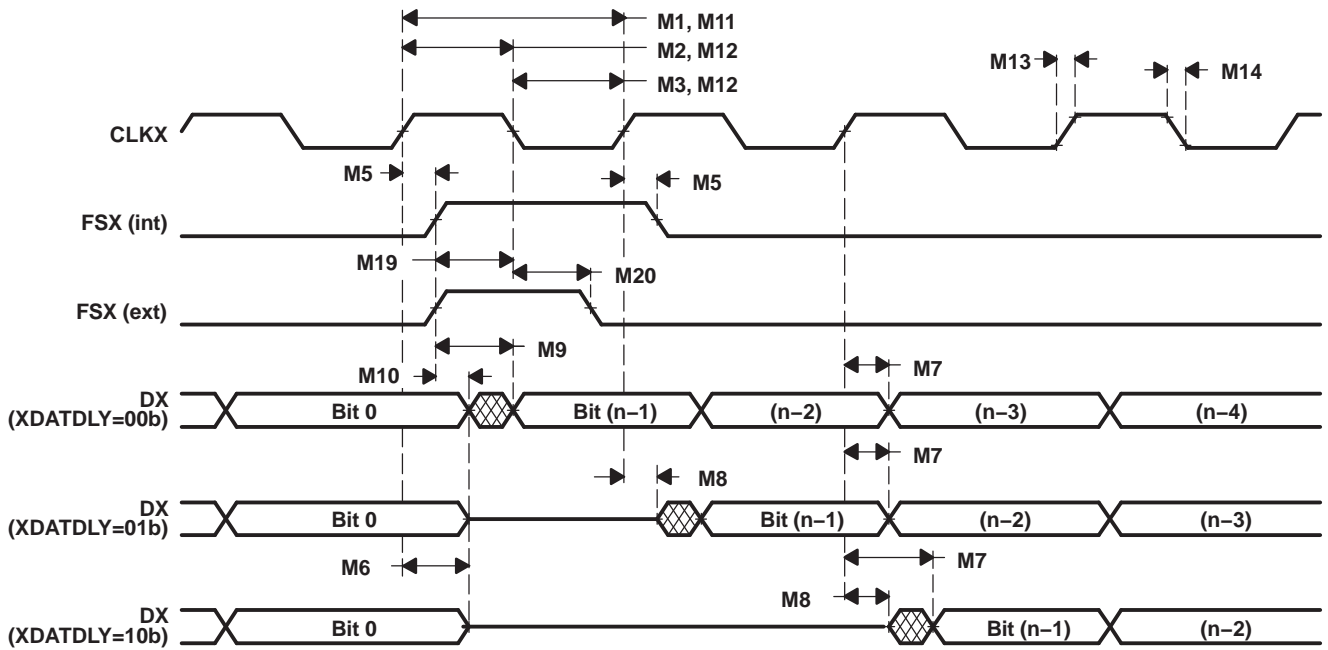

Figure 5-32. McBSP Transmit Timing

5.7.4.5.1.2 McBSP as SPI Master or Slave Timing

Table 5-35. McBSP as SPI Master or Slave Timing Requirements (CLKSTP = 10b, CLKXP = 0)

NO.			MASTER		SLAVE		UNIT
			MIN	MAX	MIN	MAX	
M30	$t_{su}(DRV-CKXL)$	Setup time, DR valid before CLKX low	30		8P – 10		ns
M31	$t_h(CKXL-DRV)$	Hold time, DR valid after CLKX low	1		8P – 10		ns
M32	$t_{su}(BFXL-CKXH)$	Setup time, FSX low before CLKX high			8P + 10		ns
M33	$t_c(CKX)$	Cycle time, CLKX	2P <sup>(1)</sup>		16P		ns

(1) 2P = 1/CLKG

Table 5-36. McBSP as SPI Master or Slave Switching Characteristics (CLKSTP = 10b, CLKXP = 0)

over recommended operating conditions (unless otherwise noted)

NO.	PARAMETER	MASTER		SLAVE		UNIT
		MIN	MAX	MIN	MAX	
M24	$t_h(CKXL-FXL)$	2P <sup>(1)</sup>				ns
M25	$t_d(FXL-CKXH)$	P				ns
M26	$t_d(CKXH-DXV)$	-2	0	3P + 6	5P + 20	ns
M28	$t_{dis}(FXH-DXHZ)$	6		6P + 6		ns
M29	$t_d(FXL-DXV)$	6		4P + 6		ns

(1) 2P = 1/CLKG

For all SPI slave modes, CLKX must be a minimum of 8 CLKG cycles. Also CLKG should be LSPCLK/2 by setting CLKSM = CLKGDV = 1. With a maximum LSPCLK speed of 90 MHz, CLKX maximum frequency is LSPCLK/16, that is 5.625 MHz and P = 11.11 ns.

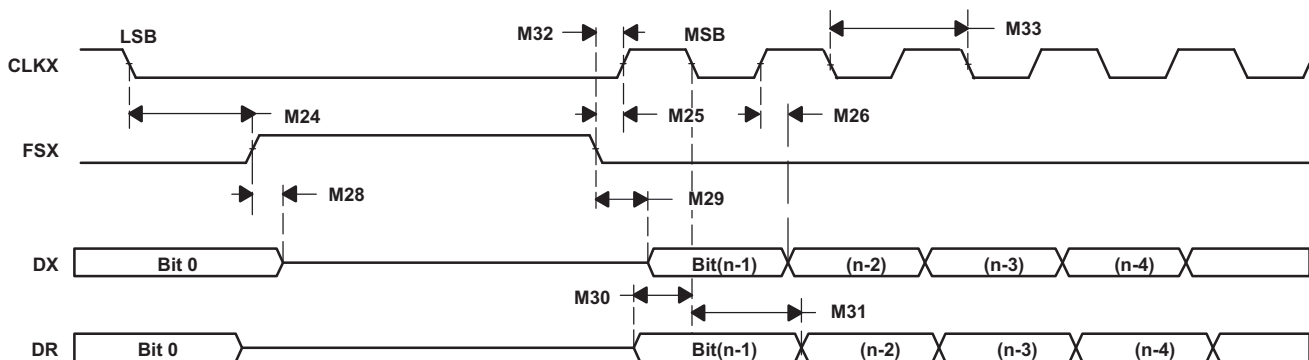

Figure 5-33. McBSP Timing as SPI Master or Slave: CLKSTP = 10b, CLKXP = 0

**Table 5-37. McBSP as SPI Master or Slave Timing Requirements (CLKSTP = 11b, CLKXP = 0)**

NO.			MASTER		SLAVE		UNIT
			MIN	MAX	MIN	MAX	
M39	$t_{su(DRV-CKXH)}$	Setup time, DR valid before CLKX high	30		8P – 10		ns
M40	$t_h(CKXH-DRV)$	Hold time, DR valid after CLKX high	1		8P – 10		ns
M41	$t_{su(FXL-CKXH)}$	Setup time, FSX low before CLKX high			16P + 10		ns
M42	$t_c(CKX)$	Cycle time, CLKX	2P <sup>(1)</sup>		16P		ns

(1) 2P = 1/CLKG

**Table 5-38. McBSP as SPI Master or Slave Switching Characteristics (CLKSTP = 11b, CLKXP = 0)**

over recommended operating conditions (unless otherwise noted)

NO.	PARAMETER	MASTER		SLAVE		UNIT
		MIN	MAX	MIN	MAX	
M34	$t_h(CKXL-FXL)$	P				ns
M35	$t_d(FXL-CKXH)$	2P <sup>(1)</sup>				ns
M36	$t_d(CKXL-DXV)$	-2	0	3P + 6	5P + 20	ns
M37	$t_{dis}(CKXL-DXHZ)$	P + 6		7P + 6		ns
M38	$t_d(FXL-DXV)$	6		4P + 6		ns

(1) 2P = 1/CLKG

For all SPI slave modes, CLKX must be a minimum of 8 CLKG cycles. Also, CLKG should be LSPCLK/2 by setting CLKSM = CLKGDV = 1. With a maximum LSPCLK speed of 90 MHz, CLKX maximum frequency is LSPCLK/16; that is, 5.625 MHz and P = 11.11 ns.

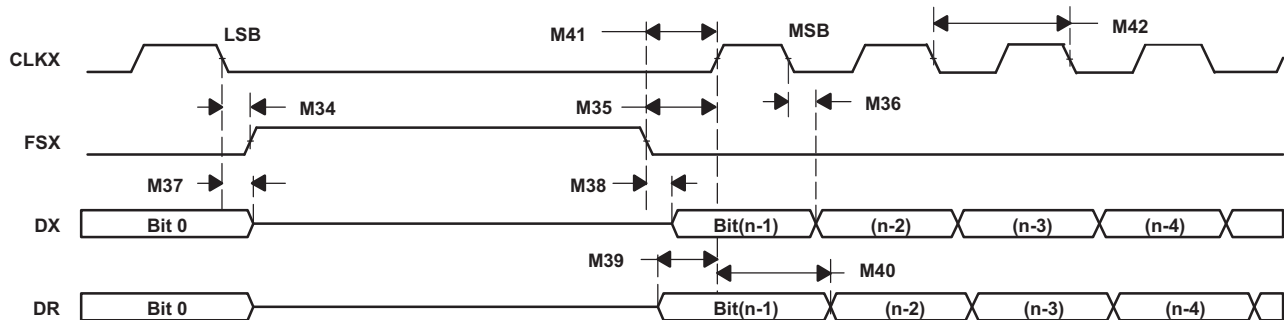

**Figure 5-34. McBSP Timing as SPI Master or Slave: CLKSTP = 11b, CLKXP = 0**

**Table 5-39. McBSP as SPI Master or Slave Timing Requirements (CLKSTP = 10b, CLKXP = 1)**

NO.			MASTER		SLAVE		UNIT
			MIN	MAX	MIN	MAX	
M49	$t_{su(DRV-CKXH)}$	Setup time, DR valid before CLKX high	30		8P – 10		ns
M50	$t_h(CKXH-DRV)$	Hold time, DR valid after CLKX high	1		8P – 10		ns
M51	$t_{su(FXL-CKXL)}$	Setup time, FSX low before CLKX low			8P + 10		ns
M52	$t_c(CKX)$	Cycle time, CLKX	2P <sup>(1)</sup>		16P		ns

(1) 2P = 1/CLKG

**Table 5-40. McBSP as SPI Master or Slave Switching Characteristics (CLKSTP = 10b, CLKXP = 1)**

over recommended operating conditions (unless otherwise noted)

NO.	PARAMETER	MASTER		SLAVE		UNIT
		MIN	MAX	MIN	MAX	
M43	$t_h(CKXH-FXL)$	2P <sup>(1)</sup>				ns
M44	$t_d(FXL-CKXL)$	P				ns
M45	$t_d(CKXL-DXV)$	-2	0	3P + 6	5P + 20	ns
M47	$t_{dis}(FXH-DXHZ)$	6			6P + 6	ns
M48	$t_d(FXL-DXV)$	6			4P + 6	ns

(1) 2P = 1/CLKG

For all SPI slave modes, CLKX must be a minimum of 8 CLKG cycles. Also, CLKG should be LSPCLK/2 by setting CLKSM = CLKGDV = 1. With a maximum LSPCLK speed of 90 MHz, CLKX maximum frequency is LSPCLK/16; that is, 5.625 MHz and P = 11.11 ns.

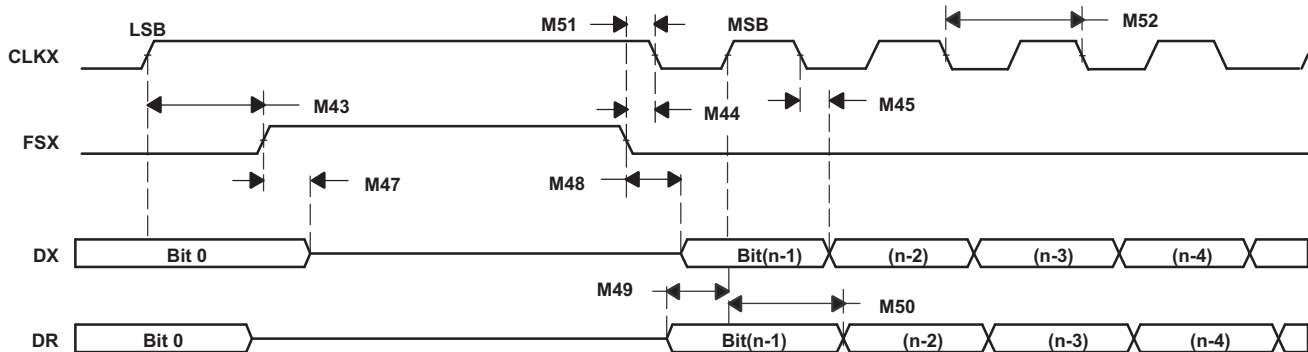

**Figure 5-35. McBSP Timing as SPI Master or Slave: CLKSTP = 10b, CLKXP = 1**

**Table 5-41. McBSP as SPI Master or Slave Timing Requirements (CLKSTP = 11b, CLKXP = 1)**

NO.			MASTER		SLAVE		UNIT
			MIN	MAX	MIN	MAX	
M58	$t_{su(DRV-CKXL)}$	Setup time, DR valid before CLKX low	30		8P – 10		ns
M59	$t_{h(CKXL-DRV)}$	Hold time, DR valid after CLKX low	1		8P – 10		ns
M60	$t_{su(FXL-CKXL)}$	Setup time, FSX low before CLKX low			16P + 10		ns
M61	$t_{c(CKX)}$	Cycle time, CLKX	2P <sup>(1)</sup>		16P		ns

(1) 2P = 1/CLKG

**Table 5-42. McBSP as SPI Master or Slave Switching Characteristics (CLKSTP = 11b, CLKXP = 1)<sup>(1)</sup>**

over recommended operating conditions (unless otherwise noted)

NO.	PARAMETER	MASTER		SLAVE		UNIT	
		MIN	MAX	MIN	MAX		
M53	$t_{h(CKXH-FXL)}$	Hold time, FSX low after CLKX high	P			ns	
M54	$t_{d(FXL-CKXL)}$	Delay time, FSX low to CLKX low	2P <sup>(1)</sup>			ns	
M55	$t_{d(CKXH-DXV)}$	Delay time, CLKX high to DX valid	-2	0	3P + 6	5P + 20	ns
M56	$t_{dis(CKXH-DXHZ)}$	Disable time, DX high impedance following last data bit from CLKX high	P + 6		7P + 6		ns
M57	$t_{d(FXL-DXV)}$	Delay time, FSX low to DX valid	6		4P + 6		ns

(1) 2P = 1/CLKG

For all SPI slave modes, CLKX must be a minimum of 8 CLKG cycles. Also CLKG should be LSPCLK/2 by setting CLKSM = CLKGDV = 1. With a maximum LSPCLK speed of 90 MHz, CLKX maximum frequency is LSPCLK/16, that is 5.625 MHz and P = 11.11 ns.

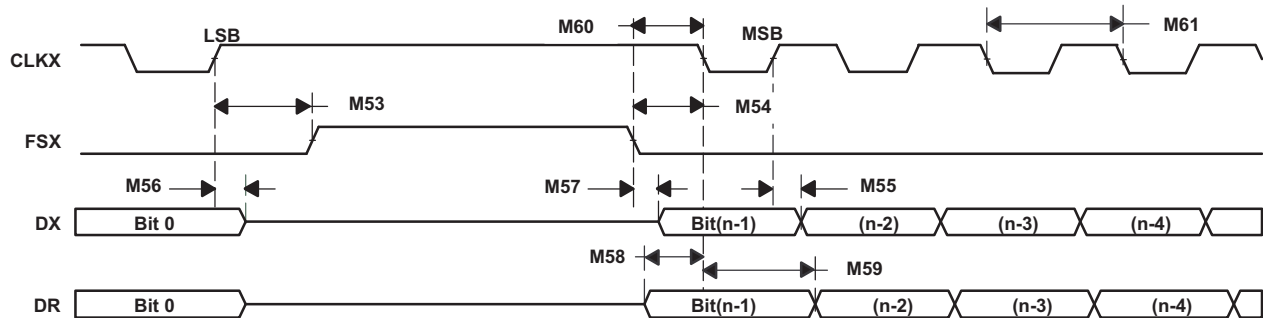

**Figure 5-36. McBSP Timing as SPI Master or Slave: CLKSTP = 11b, CLKXP = 1**

#### 5.7.4.6 Inter-Integrated Circuit

The device contains one I<sup>2</sup>C serial port. [Figure 5-37](#) shows how the I<sup>2</sup>C peripheral module interfaces within the device.

The I<sup>2</sup>C module has the following features:

- Compliance with the Philips Semiconductors I<sup>2</sup>C-bus specification (version 2.1):
  - Support for 1-bit to 8-bit format transfers
  - 7-bit and 10-bit addressing modes
  - General call
  - START byte mode
  - Support for multiple master-transmitters and slave-receivers
  - Support for multiple slave-transmitters and master-receivers
  - Combined master transmit/receive and receive/transmit mode
  - Data transfer rate of from 10 kbps up to 400 kbps (I<sup>2</sup>C Fast-mode rate)
- One 4-word receive FIFO and one 4-word transmit FIFO
- One interrupt that can be used by the CPU. This interrupt can be generated as a result of one of the following conditions:
  - Transmit-data ready
  - Receive-data ready
  - Register-access ready
  - No-acknowledgment received
  - Arbitration lost
  - Stop condition detected
  - Addressed as slave
- An additional interrupt that can be used by the CPU when in FIFO mode
- Module enable/disable capability
- Free data format mode

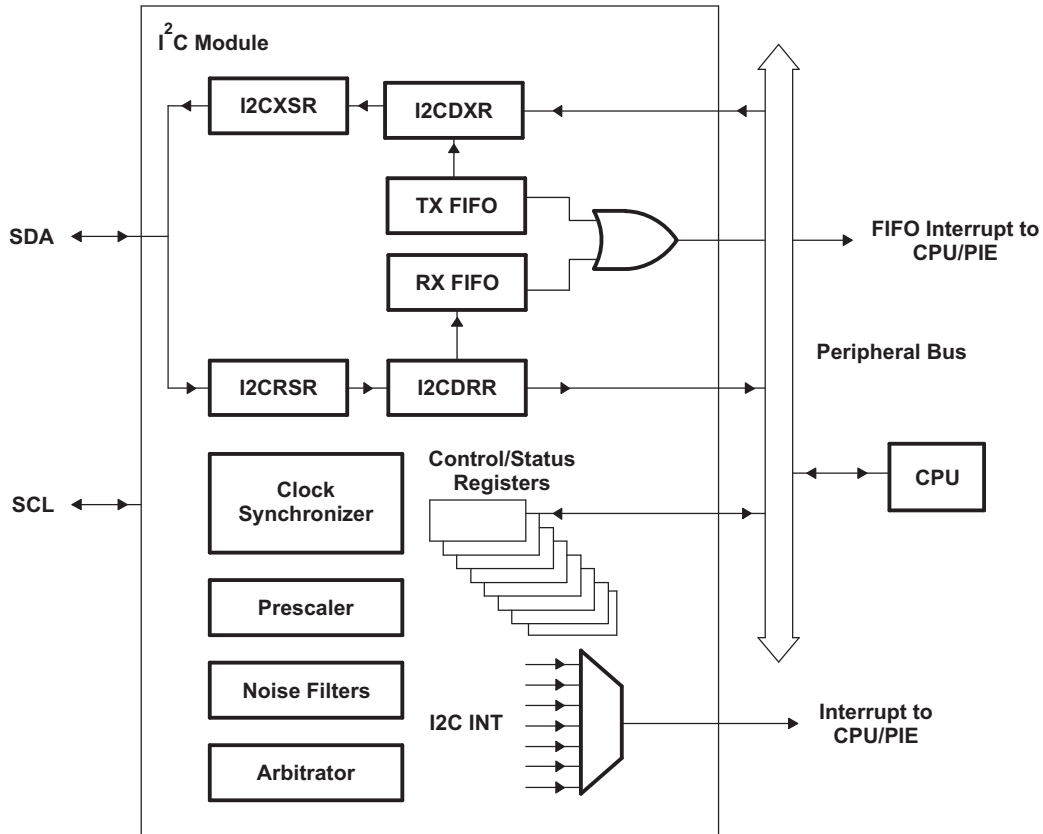

- A. The I<sup>2</sup>C registers are accessed at the SYSCLKOUT rate. The internal timing and signal waveforms of the I<sup>2</sup>C port are also at the SYSCLKOUT rate.
- B. The clock enable bit (I2CAENCLK) in the PCLKCRO register turns off the clock to the I<sup>2</sup>C port for low power operation. Upon reset, I2CAENCLK is clear, which indicates the peripheral internal clocks are off.

**Figure 5-37. I<sup>2</sup>C Peripheral Module Interfaces**

The registers in [Table 5-43](#) configure and control the I<sup>2</sup>C port operation.

**Table 5-43. I2C-A Registers**

NAME	ADDRESS	EALLOW PROTECTED	DESCRIPTION
I2COAR	0x7900	No	I <sup>2</sup> C own address register
I2CIER	0x7901	No	I <sup>2</sup> C interrupt enable register
I2CSTR	0x7902	No	I <sup>2</sup> C status register
I2CCLKL	0x7903	No	I <sup>2</sup> C clock low-time divider register
I2CCLKH	0x7904	No	I <sup>2</sup> C clock high-time divider register
I2CCNT	0x7905	No	I <sup>2</sup> C data count register
I2CDRR	0x7906	No	I <sup>2</sup> C data receive register
I2CSAR	0x7907	No	I <sup>2</sup> C slave address register
I2CDXR	0x7908	No	I <sup>2</sup> C data transmit register
I2CMDR	0x7909	No	I <sup>2</sup> C mode register
I2CISRC	0x790A	No	I <sup>2</sup> C interrupt source register
I2CPSC	0x790C	No	I <sup>2</sup> C prescaler register
I2CFFTX	0x7920	No	I <sup>2</sup> C FIFO transmit register
I2CFFRX	0x7921	No	I <sup>2</sup> C FIFO receive register
I2CRSR	–	No	I <sup>2</sup> C receive shift register (not accessible to the CPU)
I2CXSR	–	No	I <sup>2</sup> C transmit shift register (not accessible to the CPU)

### 5.7.4.6.1 I<sup>2</sup>C Electrical Data/Timing

**Table 5-44. I<sup>2</sup>C Timing**

		TEST CONDITIONS	MIN	MAX	UNIT
f <sub>SCL</sub>	SCL clock frequency	I <sup>2</sup> C clock module frequency is between 7 MHz and 12 MHz and I <sup>2</sup> C prescaler and clock divider registers are configured appropriately		400	kHz
v <sub>il</sub>	Low level input voltage			0.3 V <sub>DDIO</sub>	V
V <sub>ih</sub>	High level input voltage		0.7 V <sub>DDIO</sub>		V
V <sub>hys</sub>	Input hysteresis		0.05 V <sub>DDIO</sub>		V
V <sub>ol</sub>	Low level output voltage	3 mA sink current	0	0.4	V
t <sub>LOW</sub>	Low period of SCL clock	I <sup>2</sup> C clock module frequency is between 7 MHz and 12 MHz and I <sup>2</sup> C prescaler and clock divider registers are configured appropriately	1.3		μs
t <sub>HIGH</sub>	High period of SCL clock	I <sup>2</sup> C clock module frequency is between 7 MHz and 12 MHz and I <sup>2</sup> C prescaler and clock divider registers are configured appropriately	0.6		μs
I <sub>i</sub>	Input current with an input voltage between 0.1 V <sub>DDIO</sub> and 0.9 V <sub>DDIO</sub> MAX		-10	10	μA

### 5.7.4.7 Enhanced Pulse Width Modulator Module

The F28PLC8x device contains two ePWM modules (ePWM1, ePWM2). Figure 5-38 shows a block diagram of the ePWM modules. Figure 5-39 shows the signal interconnections with the ePWM.

Table 5-45 shows the complete ePWM register set per module.

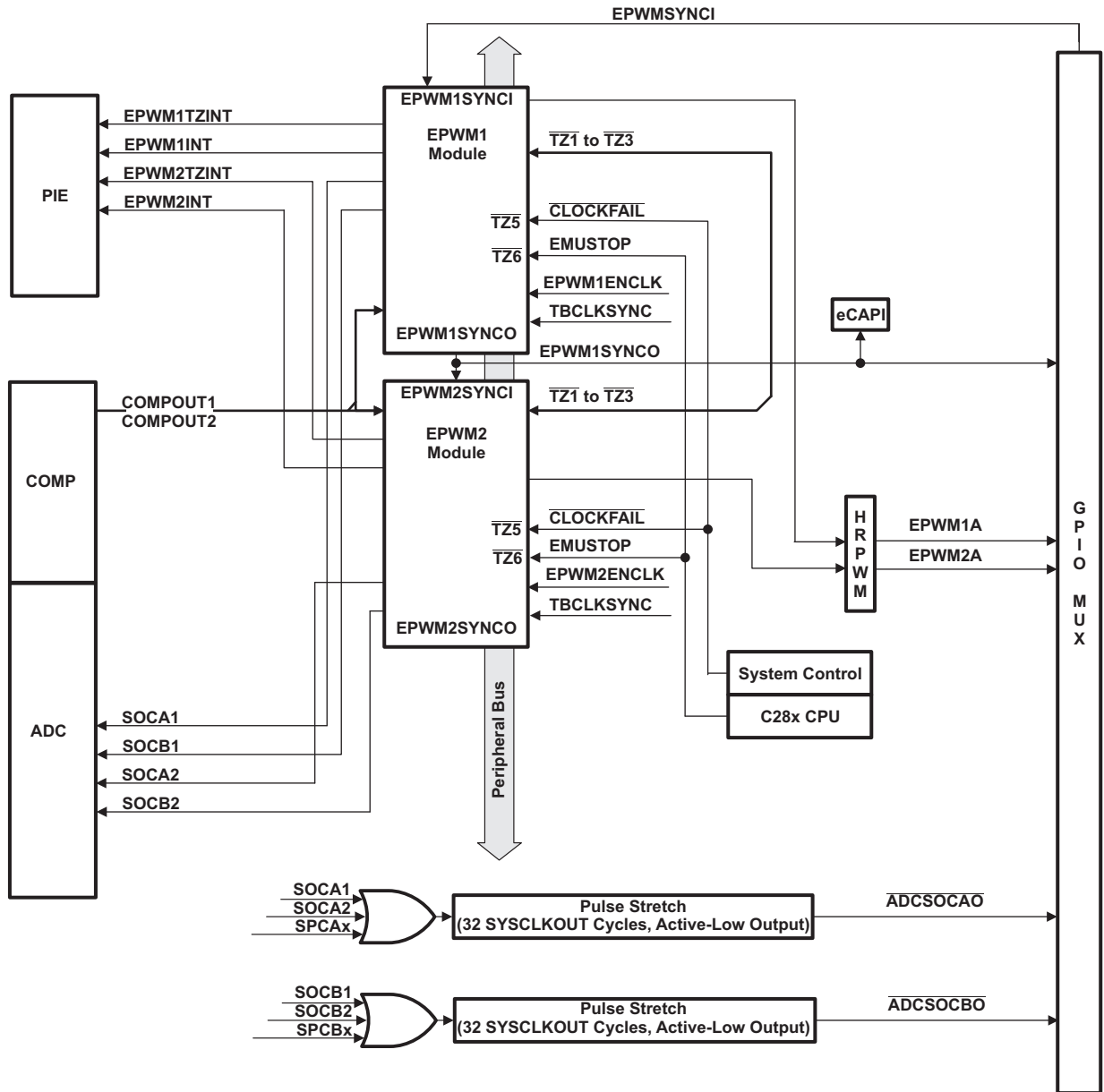

Figure 5-38. ePWM

Table 5-45. ePWM1–ePWM2 Control and Status Registers

NAME	ePWM1	ePWM2	SIZE (x16) / #SHADOW	DESCRIPTION
TBCTL	0x6800	0x6840	1 / 0	Time Base Control Register
TBSTS	0x6801	0x6841	1 / 0	Time Base Status Register
TBPHSHR	0x6802	0x6842	1 / 0	Time Base Phase HRPWM Register
TBPHS	0x6803	0x6843	1 / 0	Time Base Phase Register
TBCTR	0x6804	0x6844	1 / 0	Time Base Counter Register
TBPRD	0x6805	0x6845	1 / 1	Time Base Period Register Set
TBPRDHR	0x6806	0x6846	1 / 1	Time Base Period High Resolution Register <sup>(1)</sup>
CMPCTL	0x6807	0x6847	1 / 0	Counter Compare Control Register
CMPAHR	0x6808	0x6848	1 / 1	Time Base Compare A HRPWM Register
CMPA	0x6809	0x6849	1 / 1	Counter Compare A Register Set
CMPB	0x680A	0x684A	1 / 1	Counter Compare B Register Set
AQCTLA	0x680B	0x684B	1 / 0	Action Qualifier Control Register For Output A
AQCTLB	0x680C	0x684C	1 / 0	Action Qualifier Control Register For Output B
AQSFR	0x680D	0x684D	1 / 0	Action Qualifier Software Force Register
AQCSFR	0x680E	0x684E	1 / 1	Action Qualifier Continuous S/W Force Register Set
DBCTL	0x680F	0x684F	1 / 1	Dead-Band Generator Control Register
DBRED	0x6810	0x6850	1 / 0	Dead-Band Generator Rising Edge Delay Count Register
DBFED	0x6811	0x6851	1 / 0	Dead-Band Generator Falling Edge Delay Count Register
TZSEL	0x6812	0x6852	1 / 0	Trip Zone Select Register <sup>(1)</sup>
TZDCSEL	0x6813	0x6853	1 / 0	Trip Zone Digital Compare Register
TZCTL	0x6814	0x6854	1 / 0	Trip Zone Control Register <sup>(1)</sup>
TZEINT	0x6815	0x6855	1 / 0	Trip Zone Enable Interrupt Register <sup>(1)</sup>
TZFLG	0x6816	0x6856	1 / 0	Trip Zone Flag Register <sup>(1)</sup>
TZCLR	0x6817	0x6857	1 / 0	Trip Zone Clear Register <sup>(1)</sup>
TZFRC	0x6818	0x6858	1 / 0	Trip Zone Force Register <sup>(1)</sup>
ETSEL	0x6819	0x6859	1 / 0	Event Trigger Selection Register
ETPS	0x681A	0x685A	1 / 0	Event Trigger Prescale Register
ETFLG	0x681B	0x685B	1 / 0	Event Trigger Flag Register
ETCLR	0x681C	0x685C	1 / 0	Event Trigger Clear Register
ETFRC	0x681D	0x685D	1 / 0	Event Trigger Force Register
PCCTL	0x681E	0x685E	1 / 0	PWM Chopper Control Register
HRCNFG	0x6820	0x6860	1 / 0	HRPWM Configuration Register <sup>(1)</sup>
HRMSTEP	0x6826	-	1 / 0	HRPWM MEP Step Register
HRPCTL	0x6828	0x6868	1 / 0	High resolution Period Control Register <sup>(1)</sup>
TBPRDHRM	0x682A	0x686A	1 / W <sup>(2)</sup>	Time Base Period HRPWM Register Mirror
TBPRDM	0x682B	0x686B	1 / W <sup>(2)</sup>	Time Base Period Register Mirror
CMPAHRM	0x682C	0x686C	1 / W <sup>(2)</sup>	Compare A HRPWM Register Mirror
CMPAM	0x682D	0x686D	1 / W <sup>(2)</sup>	Compare A Register Mirror
DCTRIPSEL	0x6830	0x6870	1 / 0	Digital Compare Trip Select Register <sup>(1)</sup>
DCACTL	0x6831	0x6871	1 / 0	Digital Compare A Control Register <sup>(1)</sup>
DCBCTL	0x6832	0x6872	1 / 0	Digital Compare B Control Register <sup>(1)</sup>
DCFCTL	0x6833	0x6873	1 / 0	Digital Compare Filter Control Register <sup>(1)</sup>
DCCAPCT	0x6834	0x6874	1 / 0	Digital Compare Capture Control Register <sup>(1)</sup>
DCOFFSET	0x6835	0x6875	1 / 1	Digital Compare Filter Offset Register
DCOFFSETCNT	0x6836	0x6876	1 / 0	Digital Compare Filter Offset Counter Register

(1) Registers that are EALLOW protected.

(2) W = Write to shadow register



**5.7.4.7.1 ePWM Electrical Data/Timing**

PWM refers to PWM outputs on ePWM1–2. Table 5-46 shows the PWM timing requirements and Table 5-47, switching characteristics.

**Table 5-46. ePWM Timing Requirements<sup>(1)</sup>**

		MIN	MAX	UNIT
$t_{w(SYCIN)}$	Sync input pulse width	Asynchronous	$2t_{c(SCO)}$	cycles
		Synchronous	$2t_{c(SCO)}$	cycles
		With input qualifier	$1t_{c(SCO)} + t_{w(IQSW)}$	cycles

(1) For an explanation of the input qualifier parameters, see Table 5-58.

**Table 5-47. ePWM Switching Characteristics**

over recommended operating conditions (unless otherwise noted)

PARAMETER	TEST CONDITIONS	MIN	MAX	UNIT
$t_{w(PWM)}$	Pulse duration, PWMx output high/low	33.33		ns
$t_{w(SYNCOUT)}$	Sync output pulse width	$8t_{c(SCO)}$		cycles
$t_{d(PWM)tza}$	Delay time, trip input active to PWM forced high		25	ns
	Delay time, trip input active to PWM forced low	no pin load		
$t_{d(TZ-PWM)HZ}$	Delay time, trip input active to PWM Hi-Z		20	ns

**5.7.4.7.2 Trip-Zone Input Timing**

**Table 5-48. Trip-Zone Input Timing Requirements<sup>(1)</sup>**

		MIN	MAX	UNIT
$t_{w(TZ)}$	Pulse duration, $\overline{TZx}$ input low	Asynchronous	$2t_{c(TBCLK)}$	cycles
		Synchronous	$2t_{c(TBCLK)}$	cycles
		With input qualifier	$2t_{c(TBCLK)} + t_{w(IQSW)}$	cycles

(1) For an explanation of the input qualifier parameters, see Table 5-58.

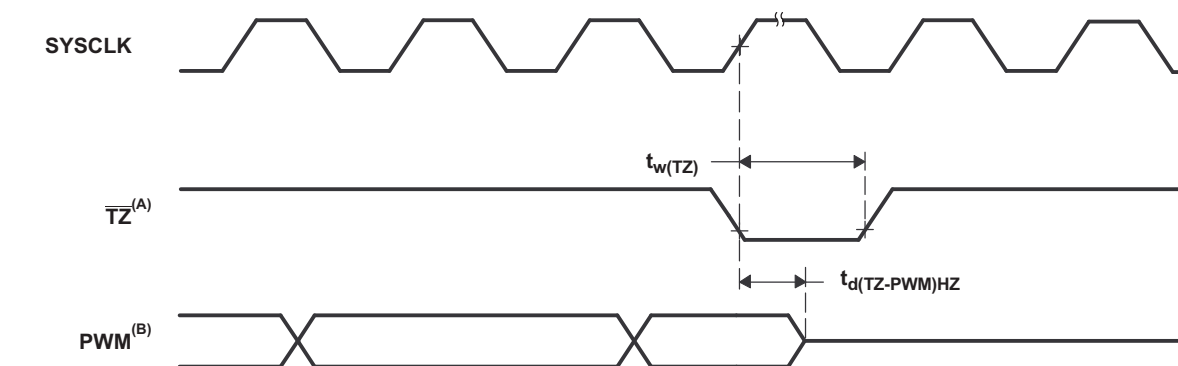

- A.  $\overline{TZ} - \overline{TZ1}, \overline{TZ2}, \overline{TZ3}, \overline{TZ4}, \overline{TZ5}, \overline{TZ6}$
- B. PWM refers to all the PWM pins in the device. The state of the PWM pins after  $\overline{TZ}$  is taken high depends on the PWM recovery software.

**Figure 5-40. PWM Hi-Z Characteristics**

### 5.7.4.8 High-Resolution PWM

This module combines multiple delay lines in a single module and a simplified calibration system by using a dedicated calibration delay line. For each ePWM module there is one HR delay line.

The HRPWM module offers PWM resolution (time granularity) that is significantly better than what can be achieved using conventionally derived digital PWM methods. The key points for the HRPWM module are:

- Significantly extends the time resolution capabilities of conventionally derived digital PWM
- This capability can be utilized in both single edge (duty cycle and phase-shift control) as well as dual edge control for frequency/period modulation.
- Finer time granularity control or edge positioning is controlled via extensions to the Compare A and Phase registers of the ePWM module.
- HRPWM capabilities, when available on a particular device, are offered only on the A signal path of an ePWM module (that is, on the EPWMxA output). EPWMxB output has conventional PWM capabilities.

---

#### NOTE

The minimum SYSCLKOUT frequency allowed for HRPWM is 60 MHz.

---

#### NOTE

When dual-edge high-resolution is enabled (high-resolution period mode), the PWMxB channel will have  $\pm 1-2$  TBCLK cycles of jitter on the output.

---

#### 5.7.4.8.1 HRPWM Electrical Data/Timing

[Table 5-49](#) shows the high-resolution PWM switching characteristics.

**Table 5-49. High-Resolution PWM Characteristics<sup>(1)</sup>**

PARAMETER	MIN	TYP	MAX	UNIT
Micro Edge Positioning (MEP) step size <sup>(2)</sup>		150	310	ps

(1) The HRPWM operates at a minimum SYSCLKOUT frequency of 60 MHz.

(2) Maximum MEP step size is based on worst-case process, maximum temperature and minimum voltage. MEP step size will increase with low voltage and high temperature and decrease with voltage and cold temperature. Applications that use the HRPWM feature should use MEP Scale Factor Optimizer (SFO) estimation software functions. See the TI software libraries for details of using SFO function in end applications. SFO functions help to estimate the number of MEP steps per SYSCLKOUT period dynamically while the HRPWM is in operation.



Table 5-50 lists the eCAP Control and Status Registers.

**Table 5-50. eCAP Control and Status Registers**

NAME	eCAP1	SIZE (x16)	EALLOW PROTECTED	DESCRIPTION
TSCTR	0x6A00	2	No	Time-Stamp Counter
CTRPHS	0x6A02	2	No	Counter Phase Offset Value Register
CAP1	0x6A04	2	No	Capture 1 Register
CAP2	0x6A06	2	No	Capture 2 Register
CAP3	0x6A08	2	No	Capture 3 Register
CAP4	0x6A0A	2	No	Capture 4 Register
Reserved	0x6A0C – 0x6A12	8	No	Reserved
ECCTL1	0x6A14	1	No	Capture Control Register 1
ECCTL2	0x6A15	1	No	Capture Control Register 2
ECEINT	0x6A16	1	No	Capture Interrupt Enable Register
ECFLG	0x6A17	1	No	Capture Interrupt Flag Register
ECCLR	0x6A18	1	No	Capture Interrupt Clear Register
ECFRC	0x6A19	1	No	Capture Interrupt Force Register
Reserved	0x6A1A – 0x6A1F	6	No	Reserved

#### 5.7.4.9.1 eCAP Electrical Data/Timing

Table 5-51 shows the eCAP timing requirement and Table 5-52 shows the eCAP switching characteristics.

**Table 5-51. eCAP Timing Requirements<sup>(1)</sup>**

		MIN	MAX	UNIT
$t_{w(CAP)}$	Capture input pulse width	Asynchronous	$2t_{c(SCO)}$	cycles
		Synchronous	$2t_{c(SCO)}$	cycles
		With input qualifier	$1t_{c(SCO)} + t_{w(IQSW)}$	cycles

(1) For an explanation of the input qualifier parameters, see Table 5-58.

**Table 5-52. eCAP Switching Characteristics**

over recommended operating conditions (unless otherwise noted)

PARAMETER	MIN	MAX	UNIT
$t_{w(APWM)}$ Pulse duration, APWMx output high/low	20		ns

### 5.7.4.10 JTAG Port

On the F28PLC8x device, the JTAG port is reduced to 5 pins ( $\overline{\text{TRST}}$ , TCK, TDI, TMS, TDO). TCK, TDI, TMS and TDO pins are also GPIO pins. The  $\overline{\text{TRST}}$  signal selects either JTAG or GPIO operating mode for the pins in Figure 5-42. During emulation/debug, the GPIO function of these pins are not available. If the GPIO38/TCK/XCLKIN pin is used to provide an external clock, an alternate clock source should be used to clock the device during emulation/debug since this pin will be needed for the TCK function.

#### NOTE

In the F28PLC8x device, the JTAG pins may also be used as GPIO pins. Care should be taken in the board design to ensure that the circuitry connected to these pins do not affect the emulation capabilities of the JTAG pin function. Any circuitry connected to these pins should not prevent the emulator from driving (or being driven by) the JTAG pins for successful debug.

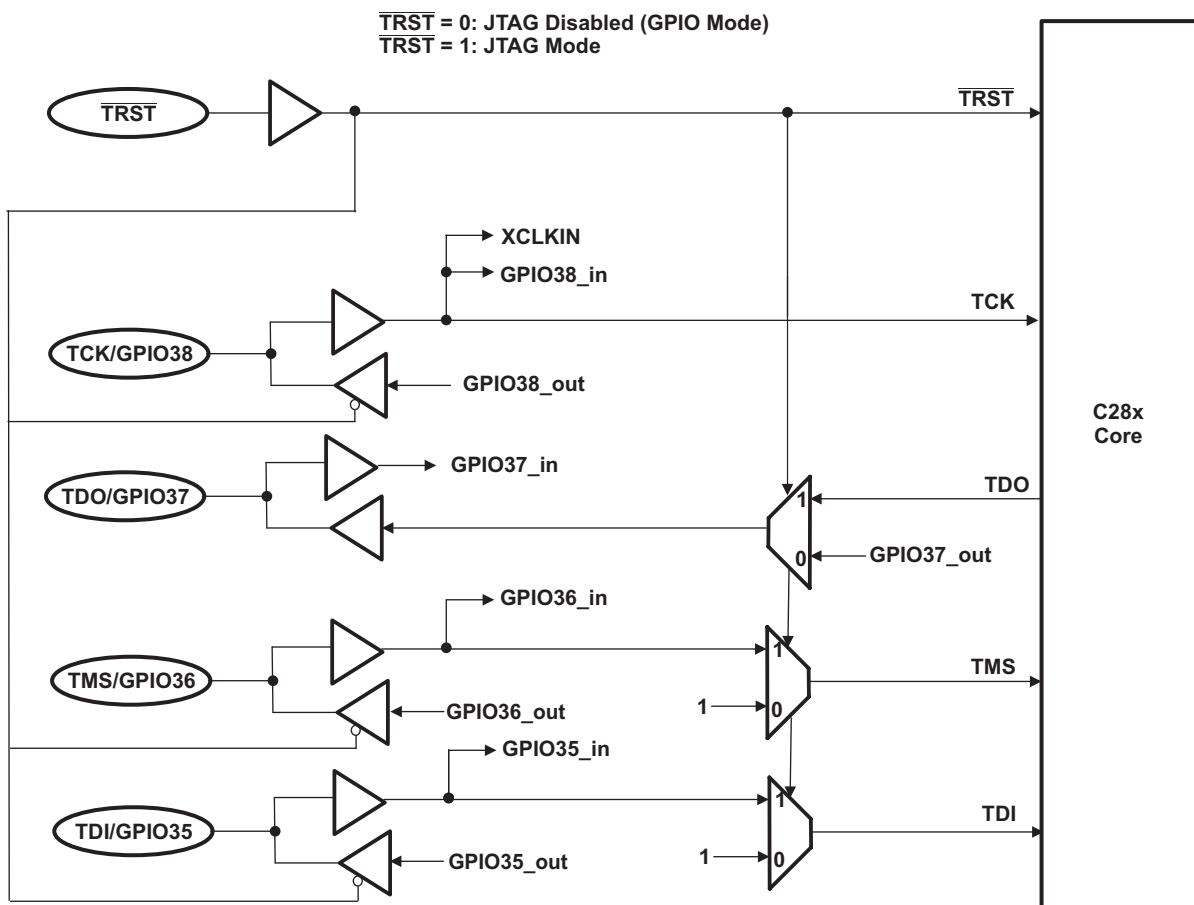

Figure 5-42. JTAG/GPIO Multiplexing

### 5.7.4.11 General-Purpose Input/Output MUX

The GPIO MUX can multiplex up to three independent peripheral signals on a single GPIO pin in addition to providing individual pin bit-banging I/O capability.

The device supports 45 GPIO pins. The GPIO control and data registers are mapped to Peripheral Frame 1 to enable 32-bit operations on the registers (along with 16-bit operations). [Table 5-53](#) shows the GPIO register mapping.

**Table 5-53. GPIO Registers**

NAME	ADDRESS	SIZE (x16)	DESCRIPTION
<b>GPIO CONTROL REGISTERS (EALLOW PROTECTED)</b>			
GPACTRL	0x6F80	2	GPIO A Control Register (GPIO0 to 31)
GPAQSEL1	0x6F82	2	GPIO A Qualifier Select 1 Register (GPIO0 to 15)
GPAQSEL2	0x6F84	2	GPIO A Qualifier Select 2 Register (GPIO16 to 31)
GPAMUX1	0x6F86	2	GPIO A MUX 1 Register (GPIO0 to 15)
GPAMUX2	0x6F88	2	GPIO A MUX 2 Register (GPIO16 to 31)
GPADIR	0x6F8A	2	GPIO A Direction Register (GPIO0 to 31)
GPAPUD	0x6F8C	2	GPIO A Pullup Disable Register (GPIO0 to 31)
GPBCTRL	0x6F90	2	GPIO B Control Register (GPIO32 to 44)
GPBQSEL1	0x6F92	2	GPIO B Qualifier Select 1 Register (GPIO32 to 44)
GPBMUX1	0x6F96	2	GPIO B MUX 1 Register (GPIO32 to 44)
GPBDIR	0x6F9A	2	GPIO B Direction Register (GPIO32 to 44)
GPBPUD	0x6F9C	2	GPIO B Pullup Disable Register (GPIO32 to 44)
AIOMUX1	0x6FB6	2	Analog, I/O mux 1 register (AIO0 to AIO15)
AIODIR	0x6FBA	2	Analog, I/O Direction Register (AIO0 to AIO15)
<b>GPIO DATA REGISTERS (NOT EALLOW PROTECTED)</b>			
GPADAT	0x6FC0	2	GPIO A Data Register (GPIO0 to 31)
GPASET	0x6FC2	2	GPIO A Data Set Register (GPIO0 to 31)
GPACLEAR	0x6FC4	2	GPIO A Data Clear Register (GPIO0 to 31)
GPATOGGLE	0x6FC6	2	GPIO A Data Toggle Register (GPIO0 to 31)
GPBDAT	0x6FC8	2	GPIO B Data Register (GPIO32 to 44)
GPBSET	0x6FCA	2	GPIO B Data Set Register (GPIO32 to 44)
GPBCLEAR	0x6FCC	2	GPIO B Data Clear Register (GPIO32 to 44)
GPBTOGGLE	0x6FCE	2	GPIO B Data Toggle Register (GPIO32 to 44)
AIODAT	0x6FD8	2	Analog I/O Data Register (AIO0 to AIO15)
AIOSET	0x6FDA	2	Analog I/O Data Set Register (AIO0 to AIO15)
AIOCLEAR	0x6FDC	2	Analog I/O Data Clear Register (AIO0 to AIO15)
AIOOGGLE	0x6FDE	2	Analog I/O Data Toggle Register (AIO0 to AIO15)
<b>GPIO INTERRUPT AND LOW POWER MODES SELECT REGISTERS (EALLOW PROTECTED)</b>			
GPIOXINT1SEL	0x6FE0	1	XINT1 GPIO Input Select Register (GPIO0 to 31)
GPIOXINT2SEL	0x6FE1	1	XINT2 GPIO Input Select Register (GPIO0 to 31)
GPIOXINT3SEL	0x6FE2	1	XINT3 GPIO Input Select Register (GPIO0 to 31)
GPIOLPMSSEL	0x6FE8	2	LPM GPIO Select Register (GPIO0 to 31)

#### NOTE

There is a two-SYSCLKOUT cycle delay from when the write to the GPxMUXn/AIOMUXn and GPxQSELn registers occurs to when the action is valid.

Table 5-54. GPIOA MUX<sup>(1)</sup> (2)

	DEFAULT AT RESET PRIMARY I/O FUNCTION	PERIPHERAL SELECTION 1	PERIPHERAL SELECTION 2	PERIPHERAL SELECTION 3
<b>GPAMUX1 REGISTER BITS</b>	<b>(GPAMUX1 BITS = 00)</b>	<b>(GPAMUX1 BITS = 01)</b>	<b>(GPAMUX1 BITS = 10)</b>	<b>(GPAMUX1 BITS = 11)</b>
1-0	GPIO0	EPWM1A (O)	Reserved	Reserved
3-2	GPIO1	Reserved	Reserved	COMP1OUT (O)
5-4	GPIO2	EPWM2A (O)	Reserved	Reserved
7-6	GPIO3	Reserved	SPISOMIA (I/O)	COMP2OUT (O)
9-8	GPIO4	Reserved	Reserved	Reserved
11-10	GPIO5	Reserved	SPISIMOA (I/O)	ECAP1 (I/O)
13-12	GPIO6	Reserved	EPWMSYNCI (I)	EPWMSYNCO (O)
15-14	GPIO7	Reserved	SCIRXDA (I)	Reserved
17-16	GPIO8	Reserved	Reserved	ADCSOCAO (O)
19-18	GPIO9	Reserved	SCITXDB (O)	Reserved
21-20	GPIO10	Reserved	Reserved	ADCSOCBO (O)
23-22	GPIO11	Reserved	SCIRXDB (I)	ECAP1 (I/O)
25-24	GPIO12	TZ1 (I)	SCITXDA (O)	SPISIMOB (I/O)
27-26	GPIO13	TZ2 (I)	Reserved	SPISOMIB (I/O)
29-28	GPIO14	TZ3 (I)	SCITXDB (O)	SPICLKB (I/O)
31-30	GPIO15	Reserved	SCIRXDB (I)	SPISTEB (I/O)
<b>GPAMUX2 REGISTER BITS</b>	<b>(GPAMUX2 BITS = 00)</b>	<b>(GPAMUX2 BITS = 01)</b>	<b>(GPAMUX2 BITS = 10)</b>	<b>(GPAMUX2 BITS = 11)</b>
1-0	GPIO16	SPISIMOA (I/O)	Reserved	TZ2 (I)
3-2	GPIO17	SPISOMIA (I/O)	Reserved	TZ3 (I)
5-4	GPIO18	SPICLKA (I/O)	SCITXDB (O)	XCLKOUT (O)
7-6	GPIO19/XCLKIN	SPISTEA (I/O)	SCIRXDB (I)	ECAP1 (I/O)
9-8	GPIO20	Reserved	MDXA (O)	COMP1OUT (O)
11-10	GPIO21	Reserved	MDRA (I)	COMP2OUT (O)
13-12	GPIO22	Reserved	MCLKXA (I/O)	SCITXDB (O)
15-14	GPIO23	Reserved	MFSXA (I/O)	SCIRXDB (I)
17-16	GPIO24	ECAP1 (I/O)	Reserved	SPISIMOB (I/O)
19-18	GPIO25	Reserved	Reserved	SPISOMIB (I/O)
21-20	GPIO26	Reserved	Reserved	SPICLKB (I/O)
23-22	GPIO27	Reserved	Reserved	SPISTEB (I/O)
25-24	GPIO28	SCIRXDA (I)	SDAA (I/OD)	TZ2 (I)
27-26	GPIO29	SCITXDA (O)	SCLA (I/OD)	TZ3 (I)
29-28	GPIO30	Reserved	Reserved	Reserved
31-30	GPIO31	Reserved	Reserved	Reserved

(1) The word "Reserved" means that there is no peripheral assigned to this GPxMUX1/2 register setting. Should the Reserved GPxMUX1/2 register setting be selected, the state of the pin will be undefined and the pin may be driven. This selection is a reserved configuration for future expansion.

(2) I = Input, O = Output, OD = Open Drain

**Table 5-55. GPIOB MUX<sup>(1)(2)</sup>**

	DEFAULT AT RESET PRIMARY I/O FUNCTION	PERIPHERAL SELECTION 1	PERIPHERAL SELECTION 2	PERIPHERAL SELECTION 3
GPBMUX1 REGISTER BITS	(GPBMUX1 BITS = 00)	(GPBMUX1 BITS = 01)	(GPBMUX1 BITS = 10)	(GPBMUX1 BITS = 11)
1-0	GPIO32	SDAA (I/OD)	EPWMSYNCl (I)	ADCSOCAO (O)
3-2	GPIO33	SCLA (I/OD)	EPWMSYNCO (O)	ADCSOCBO (O)
5-4	GPIO34	COMP2OUT (O)	Reserved	COMP3OUT (O)
7-6	GPIO35 (TDI)	Reserved	Reserved	Reserved
9-8	GPIO36 (TMS)	Reserved	Reserved	Reserved
11-10	GPIO37 (TDO)	Reserved	Reserved	Reserved
13-12	GPIO38/XCLKIN (TCK)	Reserved	Reserved	Reserved
15-14	GPIO39	Reserved	Reserved	Reserved
17-16	Reserved	Reserved	Reserved	Reserved
19-18	Reserved	Reserved	Reserved	Reserved
21-20	Reserved	Reserved	Reserved	Reserved
23-22	Reserved	Reserved	Reserved	Reserved
25-24	Reserved	Reserved	Reserved	Reserved
27-26	Reserved	Reserved	Reserved	Reserved
29-28	Reserved	Reserved	Reserved	Reserved
31-30	Reserved	Reserved	Reserved	Reserved

- (1) The word "Reserved" means that there is no peripheral assigned to this GPxMUX1/2 register setting. Should the Reserved GPxMUX1/2 register setting be selected, the state of the pin will be undefined and the pin may be driven. This selection is a reserved configuration for future expansion.
- (2) I = Input, O = Output, OD = Open Drain

**Table 5-56. Analog MUX<sup>(1)</sup>**

		DEFAULT AT RESET
	AIOx AND PERIPHERAL SELECTION 1	PERIPHERAL SELECTION 2 AND PERIPHERAL SELECTION 3
AIOMUX1 REGISTER BITS	AIOMUX1 BITS = 0,x	AIOMUX1 BITS = 1,x
1-0	ADCINA0 (I)	ADCINA0 (I)
3-2	ADCINA1 (I)	ADCINA1 (I)
5-4	AIO2 (I/O)	Reserved
7-6	Reserved	Reserved
9-8	AIO4 (I/O)	Reserved
11-10	Reserved	Reserved
13-12	AIO6 (I/O)	Reserved
15-14	Reserved	Reserved
17-16	ADCINB0 (I)	ADCINB0 (I)
19-18	ADCINB1 (I)	ADCINB1 (I)
21-20	AIO10 (I/O)	Reserved
23-22	Reserved	Reserved
25-24	AIO12 (I/O)	Reserved
27-26	Reserved	Reserved
29-28	AIO14 (I/O)	Reserved
31-30	Reserved	Reserved

- (1) I = Input, O = Output

The user can select the type of input qualification for each GPIO pin via the GPxQSEL1/2 registers from four choices:

- Synchronization To SYSCLKOUT Only (GPxQSEL1/2 = 0, 0): This mode is the default mode of all GPIO pins at reset and this mode simply synchronizes the input signal to the system clock (SYSCLKOUT).
- Qualification Using Sampling Window (GPxQSEL1/2 = 0, 1 and 1, 0): In this mode the input signal, after synchronization to the system clock (SYSCLKOUT), is qualified by a specified number of cycles before the input is allowed to change.
- The sampling period is specified by the QUALPRD bits in the GPxCTRL register and is configurable in groups of 8 signals. The sampling period specifies a multiple of SYSCLKOUT cycles for sampling the input signal. The sampling window is either 3-samples or 6-samples wide and the output is only changed when ALL samples are the same (all 0s or all 1s) as shown in [Figure 5-45](#) (for 6 sample mode).
- No Synchronization (GPxQSEL1/2 = 1,1): This mode is used for peripherals where synchronization is not required (synchronization is performed within the peripheral).

Due to the multi-level multiplexing that is required on the device, there may be cases where a peripheral input signal can be mapped to more than one GPIO pin. Also, when an input signal is not selected, the input signal will default to either a 0 or 1 state, depending on the peripheral.

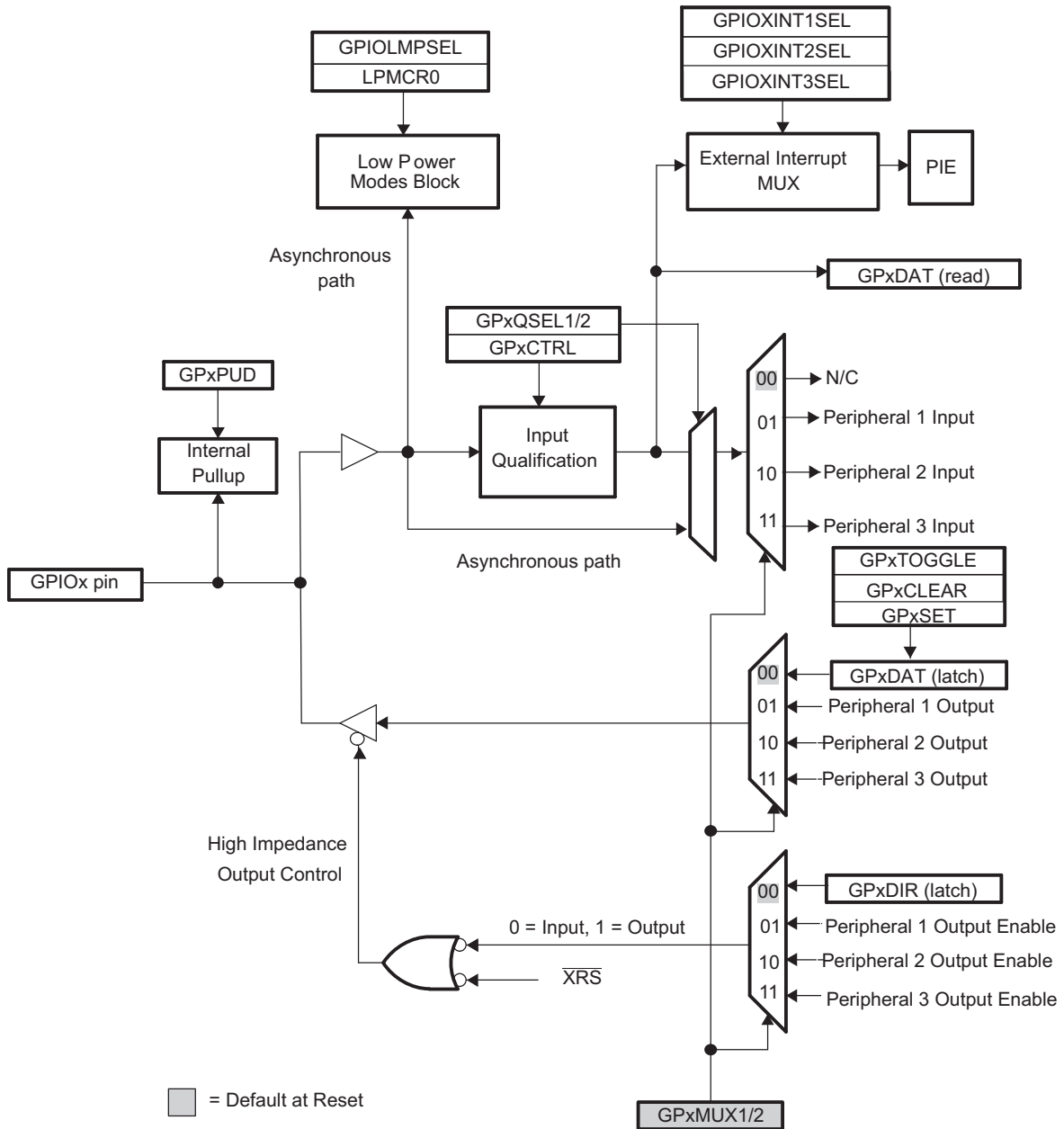

- A. x stands for the port, either A or B. For example, GPxDIR refers to either the GPADIR and GPBDIR register depending on the particular GPIO pin selected.
- B. GPxDAT latch/read are accessed at the same memory location.
- C. This diagram is a generic GPIO MUX block diagram. Not all options may be applicable for all GPIO pins.

**Figure 5-43. GPIO Multiplexing**

### 5.7.4.11.1 GPIO Electrical Data/Timing

#### 5.7.4.11.1.1 GPIO Output Timing

**Table 5-57. General-Purpose Output Switching Characteristics**

over recommended operating conditions (unless otherwise noted)

PARAMETER	TEST CONDITIONS	MIN	MAX	UNIT
$t_{r(GPO)}$	Rise time, GPIO switching low to high		13 <sup>(1)</sup>	ns
$t_{f(GPO)}$	Fall time, GPIO switching high to low		13 <sup>(1)</sup>	ns
$f_{GPO}$	Toggleing frequency		22.5	MHz

(1) Rise time and fall time vary with electrical loading on I/O pins. Values given in [Table 5-57](#) are applicable for a 40-pF load on I/O pins.

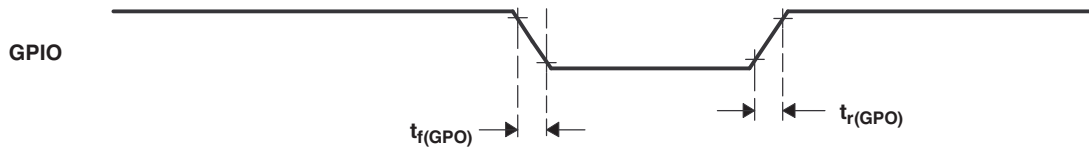

**Figure 5-44. General-Purpose Output Timing**

5.7.4.11.1.2 GPIO Input Timing

Table 5-58. General-Purpose Input Timing Requirements

		MIN	MAX	UNIT
$t_{w(SP)}$	Sampling period	QUALPRD = 0	$1t_{c(SCO)}$	cycles
		QUALPRD $\neq$ 0	$2t_{c(SCO)} * QUALPRD$	cycles
$t_{w(IQSW)}$	Input qualifier sampling window	$t_{w(SP)} * (n^{(1)} - 1)$		cycles
$t_{w(GPI)}^{(2)}$	Pulse duration, GPIO low/high	Synchronous mode	$2t_{c(SCO)}$	cycles
		With input qualifier	$t_{w(IQSW)} + t_{w(SP)} + 1t_{c(SCO)}$	cycles

(1) "n" represents the number of qualification samples as defined by GPxQSELn register.

(2) For  $t_{w(GPI)}$ , pulse width is measured from  $V_{IL}$  to  $V_{IL}$  for an active-low signal and  $V_{IH}$  to  $V_{IH}$  for an active-high signal.

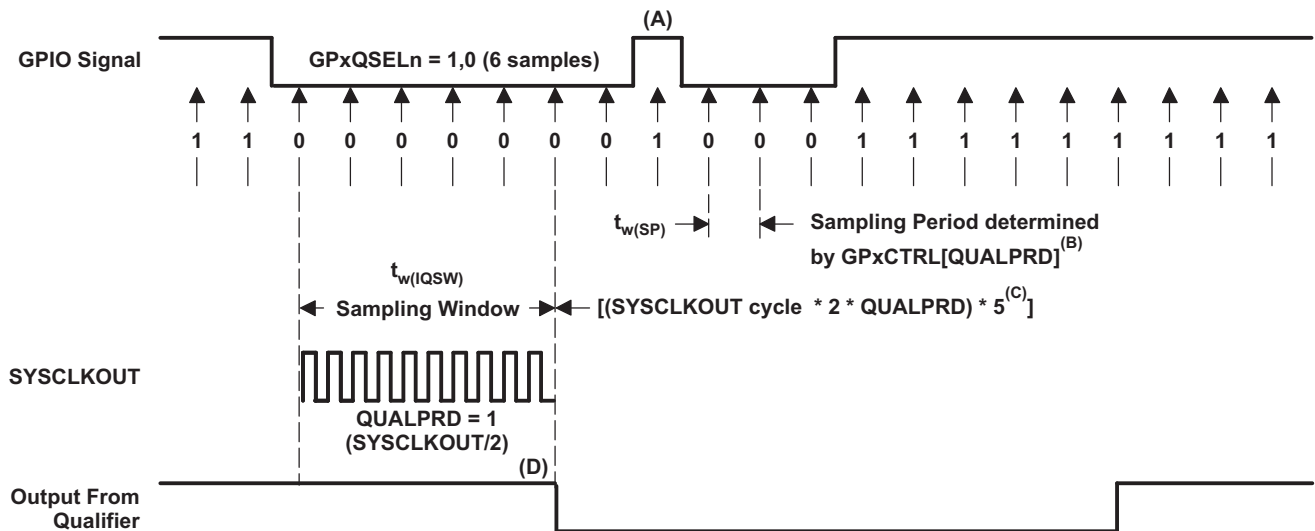

- A. This glitch will be ignored by the input qualifier. The QUALPRD bit field specifies the qualification sampling period. The QUALPRD bit field value can vary from 00 to 0xFF. If QUALPRD = 00, then the sampling period is 1 SYSCLKOUT cycle. For any other value "n", the qualification sampling period in 2n SYSCLKOUT cycles (that is, at every 2n SYSCLKOUT cycles, the GPIO pin will be sampled).
- B. The qualification period selected via the GPxCTRL register applies to groups of 8 GPIO pins.
- C. The qualification block can take either three or six samples. The GPxQSELn Register selects which sample mode is used.
- D. In the example shown, for the qualifier to detect the change, the input should be stable for 10 SYSCLKOUT cycles or greater. In other words, the inputs should be stable for (5 x QUALPRD x 2) SYSCLKOUT cycles. This condition would ensure 5 sampling periods for detection to occur. Since external signals are driven asynchronously, an 13-SYSCLKOUT-wide pulse ensures reliable recognition.

Figure 5-45. Sampling Mode

### 5.7.4.11.1.3 Sampling Window Width for Input Signals

The following section summarizes the sampling window width for input signals for various input qualifier configurations.

Sampling frequency denotes how often a signal is sampled with respect to SYSCLKOUT.

Sampling frequency =  $\text{SYSCLKOUT} / (2 * \text{QUALPRD})$ , if  $\text{QUALPRD} \neq 0$

Sampling frequency =  $\text{SYSCLKOUT}$ , if  $\text{QUALPRD} = 0$

Sampling period =  $\text{SYSCLKOUT cycle} * 2 * \text{QUALPRD}$ , if  $\text{QUALPRD} \neq 0$

In the above equations, SYSCLKOUT cycle indicates the time period of SYSCLKOUT.

Sampling period =  $\text{SYSCLKOUT cycle}$ , if  $\text{QUALPRD} = 0$

In a given sampling window, either 3 or 6 samples of the input signal are taken to determine the validity of the signal. The number of samples is determined by the value written to GPxQSELn register.

**Case 1:**

Qualification using 3 samples

Sampling window width =  $(\text{SYSCLKOUT cycle} * 2 * \text{QUALPRD}) * 2$ , if  $\text{QUALPRD} \neq 0$

Sampling window width =  $(\text{SYSCLKOUT cycle}) * 2$ , if  $\text{QUALPRD} = 0$

**Case 2:**

Qualification using 6 samples

Sampling window width =  $(\text{SYSCLKOUT cycle} * 2 * \text{QUALPRD}) * 5$ , if  $\text{QUALPRD} \neq 0$

Sampling window width =  $(\text{SYSCLKOUT cycle}) * 5$ , if  $\text{QUALPRD} = 0$

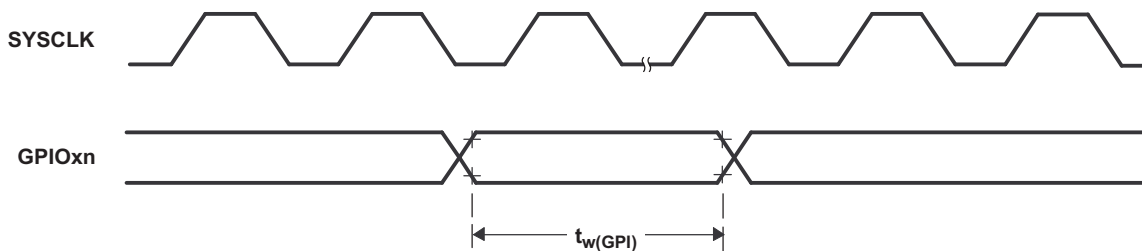

Figure 5-46. General-Purpose Input Timing

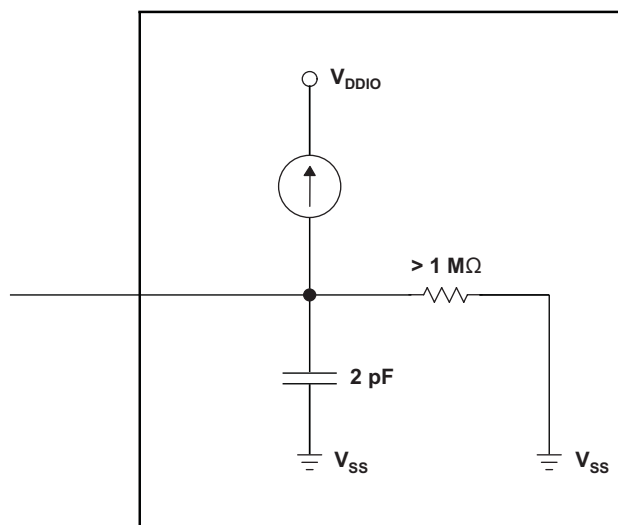

Figure 5-47. Input Resistance Model for a GPIO Pin With an Internal Pullup

5.7.4.11.1.4 Low-Power Mode Wakeup Timing

Table 5-59 shows the timing requirements, Table 5-60 shows the switching characteristics, and Figure 5-48 shows the timing diagram for IDLE mode.

Table 5-59. IDLE Mode Timing Requirements<sup>(1)</sup>

		MIN	MAX	UNIT
$t_{w(WAKE-INT)}$	Pulse duration, external wake-up signal	Without input qualifier	$2t_{c(SCO)}$	cycles
		With input qualifier	$5t_{c(SCO)} + t_{w(IQSW)}$	

(1) For an explanation of the input qualifier parameters, see Table 5-58.

Table 5-60. IDLE Mode Switching Characteristics<sup>(1)</sup>

over recommended operating conditions (unless otherwise noted)

PARAMETER		TEST CONDITIONS	MIN	MAX	UNIT
$t_{d(WAKE-IDLE)}$	Delay time, external wake signal to program execution resume <sup>(2)</sup>				cycles
	• Wake-up from Flash – Flash module in active state	Without input qualifier		$20t_{c(SCO)}$	cycles
		With input qualifier		$20t_{c(SCO)} + t_{w(IQSW)}$	
	• Wake-up from Flash – Flash module in sleep state	Without input qualifier		$1050t_{c(SCO)}$	cycles
		With input qualifier		$1050t_{c(SCO)} + t_{w(IQSW)}$	
	• Wake-up from SARAM	Without input qualifier		$20t_{c(SCO)}$	cycles
With input qualifier			$20t_{c(SCO)} + t_{w(IQSW)}$		

(1) For an explanation of the input qualifier parameters, see Table 5-58.

(2) This delay time is the time taken to begin execution of the instruction that immediately follows the IDLE instruction. execution of an ISR (triggered by the wake-up) signal involves additional latency.

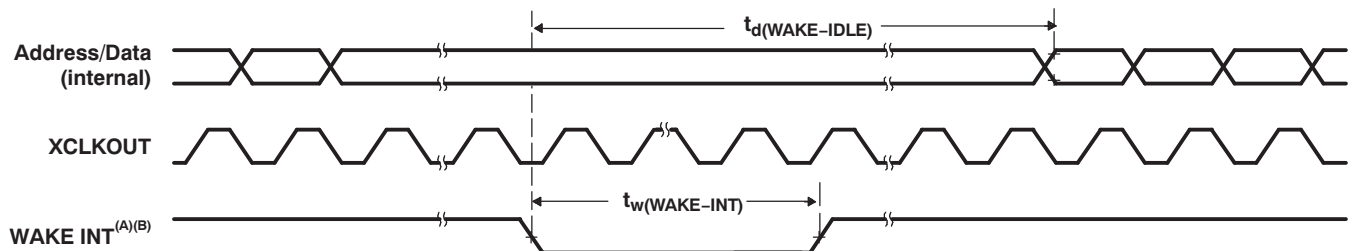

- A. WAKE INT can be any enabled interrupt,  $\overline{WDINT}$  or  $\overline{XRS}$ . After the IDLE instruction is executed, a delay of 5 OSCCLK cycles (minimum) is needed before the wake-up signal could be asserted.
- B. From the time the IDLE instruction is executed to place the device into low-power mode, wakeup should not be initiated until at least 4 OSCCLK cycles have elapsed.

Figure 5-48. IDLE Entry and Exit Timing

**Table 5-61. STANDBY Mode Timing Requirements**

			MIN	MAX	UNIT
$t_{w(WAKE-INT)}$	Pulse duration, external wake-up signal	Without input qualification	$3t_{c(OSCCLK)}$		cycles
		With input qualification <sup>(1)</sup>	$(2 + QUALSTDBY) * t_{c(OSCCLK)}$		

(1) QUALSTDBY is a 6-bit field in the LPMCR0 register.

**Table 5-62. STANDBY Mode Switching Characteristics**

over recommended operating conditions (unless otherwise noted)

PARAMETER		TEST CONDITIONS	MIN	MAX	UNIT
$t_{d(IDLE-XCOL)}$	Delay time, IDLE instruction executed to XCLKOUT low		$32t_{c(SCO)}$	$45t_{c(SCO)}$	cycles
$t_{d(WAKE-STBY)}$	Delay time, external wake signal to program execution resume <sup>(1)</sup>				cycles
	<ul style="list-style-type: none"> <li>Wake up from flash               <ul style="list-style-type: none"> <li>Flash module in active state</li> </ul> </li> </ul>	Without input qualifier	$100t_{c(SCO)}$		cycles
		With input qualifier	$100t_{c(SCO)} + t_{w(WAKE-INT)}$		
	<ul style="list-style-type: none"> <li>Wake up from flash               <ul style="list-style-type: none"> <li>Flash module in sleep state</li> </ul> </li> </ul>	Without input qualifier	$1125t_{c(SCO)}$		cycles
		With input qualifier	$1125t_{c(SCO)} + t_{w(WAKE-INT)}$		
	<ul style="list-style-type: none"> <li>Wake up from SARAM</li> </ul>	Without input qualifier	$100t_{c(SCO)}$		cycles
With input qualifier		$100t_{c(SCO)} + t_{w(WAKE-INT)}$			

(1) This delay time is the time taken to begin execution of the instruction that immediately follows the IDLE instruction. execution of an ISR (triggered by the wake up signal) involves additional latency.

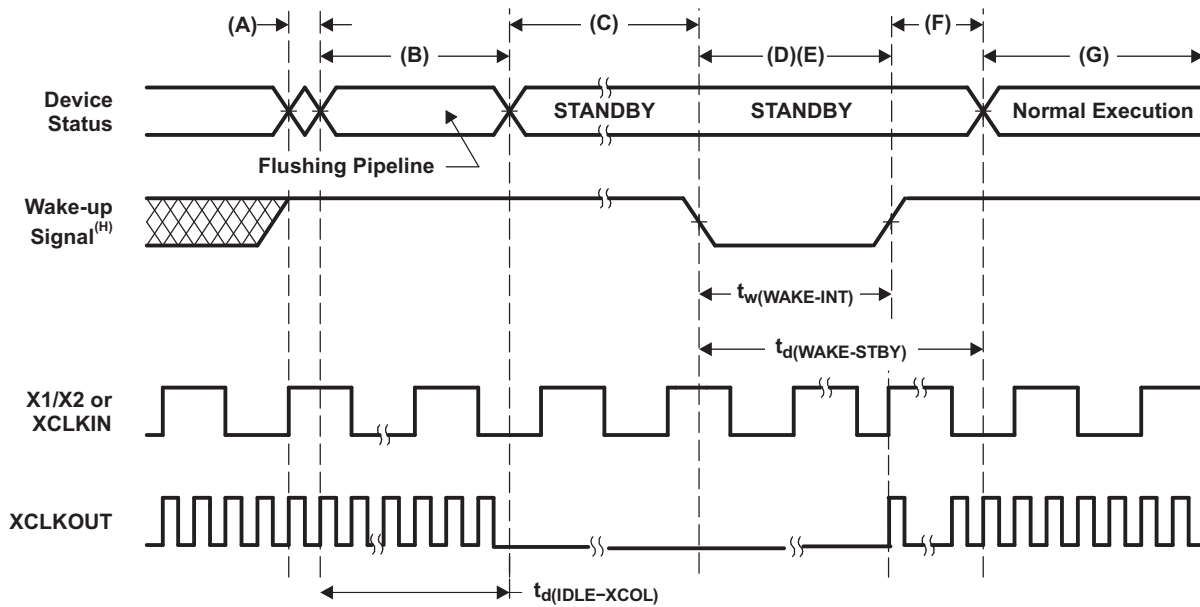

- A. IDLE instruction is executed to put the device into STANDBY mode.
- B. The PLL block responds to the STANDBY signal. SYSCLKOUT is held for the number of cycles indicated below before being turned off:
  - 16 cycles, when DIVSEL = 00 or 01
  - 32 cycles, when DIVSEL = 10
  - 64 cycles, when DIVSEL = 11
 This delay enables the CPU pipeline and any other pending operations to flush properly.
- C. Clock to the peripherals are turned off. However, the PLL and watchdog are not shut down. The device is now in STANDBY mode. After the IDLE instruction is executed, a delay of 5 OSCCLK cycles (minimum) is needed before the wake-up signal could be asserted.
- D. The external wake-up signal is driven active.
- E. The wake-up signal fed to a GPIO pin to wake up the device must meet the minimum pulse width requirement. Furthermore, this signal must be free of glitches. If a noisy signal is fed to a GPIO pin, the wake-up behavior of the device will not be deterministic and the device may not exit low-power mode for subsequent wake-up pulses.
- F. After a latency period, the STANDBY mode is exited.
- G. Normal execution resumes. The device will respond to the interrupt (if enabled).
- H. From the time the IDLE instruction is executed to place the device into low-power mode (LPM), wakeup should not be initiated until at least 4 OSCCLK cycles have elapsed.

Figure 5-49. STANDBY Entry and Exit Timing Diagram

Table 5-63. HALT Mode Timing Requirements

		MIN	MAX	UNIT
$t_w(\text{WAKE-GPIO})$	Pulse duration, GPIO wake-up signal	$t_{\text{oscst}} + 2t_c(\text{OSCCLK})$		cycles
$t_w(\text{WAKE-XRS})$	Pulse duration, XRS wakeup signal	$t_{\text{oscst}} + 8t_c(\text{OSCCLK})$		cycles

Table 5-64. HALT Mode Switching Characteristics

over recommended operating conditions (unless otherwise noted)

PARAMETER		MIN	MAX	UNIT
$t_d(\text{IDLE-XCOL})$	Delay time, IDLE instruction executed to XCLKOUT low	$32t_c(\text{SCO})$	$45t_c(\text{SCO})$	cycles
$t_p$	PLL lock-up time		1	ms
$t_d(\text{WAKE-HALT})$	Delay time, PLL lock to program execution resume		$1125t_c(\text{SCO})$	cycles
	<ul style="list-style-type: none"> <li>• Wake up from flash                             <ul style="list-style-type: none"> <li>– Flash module in sleep state</li> </ul> </li> <li>• Wake up from SARAM</li> </ul>		$35t_c(\text{SCO})$	cycles

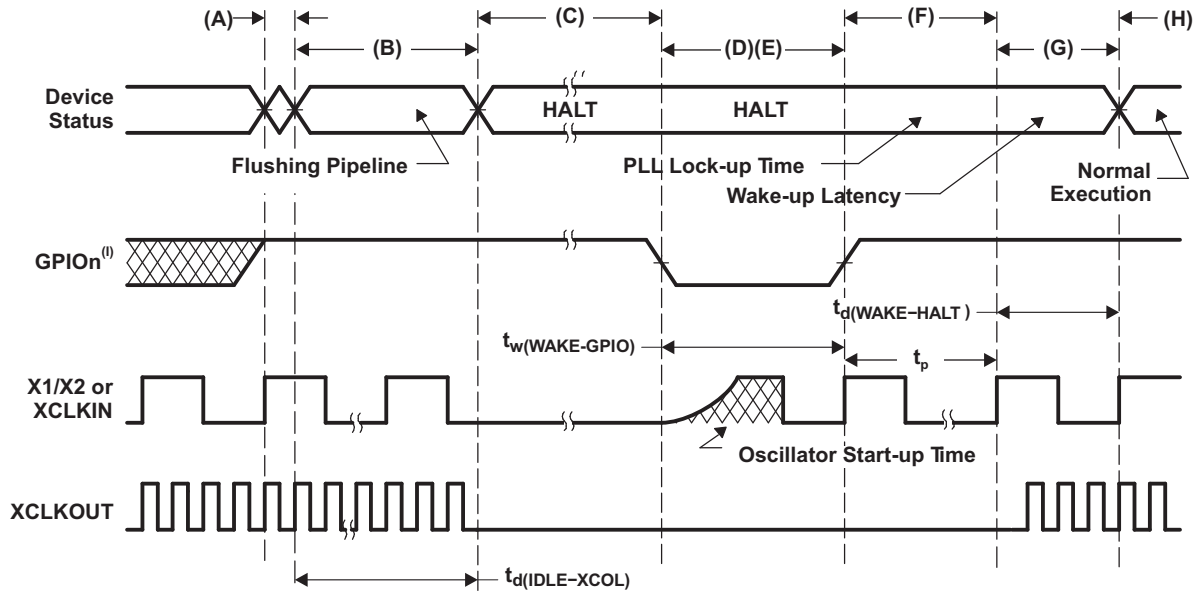

- A. IDLE instruction is executed to put the device into HALT mode.
- B. The PLL block responds to the HALT signal. SYSCLKOUT is held for the number of cycles indicated below before oscillator is turned off and the CLKIN to the core is stopped:
  - 16 cycles, when DIVSEL = 00 or 01
  - 32 cycles, when DIVSEL = 10
  - 64 cycles, when DIVSEL = 11
 This delay enables the CPU pipeline and any other pending operations to flush properly.
- C. Clocks to the peripherals are turned off and the PLL is shut down. If a quartz crystal or ceramic resonator is used as the clock source, the internal oscillator is shut down as well. The device is now in HALT mode and consumes absolute minimum power. It is possible to keep the zero-pin internal oscillators (INTOSC1 and INTOSC2) and the watchdog alive in HALT mode. Keeping INTOSC1, INTOSC2, and the watchdog alive in HALT mode is done by writing to the appropriate bits in the CLKCTL register. After the IDLE instruction is executed, a delay of 5 OSCCLK cycles (minimum) is needed before the wake-up signal could be asserted.
- D. When the GPIO<sub>n</sub> pin (used to bring the device out of HALT) is driven low, the oscillator is turned on and the oscillator wake-up sequence is initiated. The GPIO pin should be driven high only after the oscillator has stabilized, which enables the provision of a clean clock signal during the PLL lock sequence. Since the falling edge of the GPIO pin asynchronously begins the wakeup procedure, care should be taken to maintain a low noise environment prior to entering and during HALT mode.
- E. The wake-up signal fed to a GPIO pin to wake up the device must meet the minimum pulse width requirement. Furthermore, this signal must be free of glitches. If a noisy signal is fed to a GPIO pin, the wake-up behavior of the device will not be deterministic and the device may not exit low-power mode for subsequent wake-up pulses.
- F. Once the oscillator has stabilized, the PLL lock sequence is initiated, which takes 1 ms.
- G. When CLKIN to the core is enabled, the device will respond to the interrupt (if enabled), after a latency. The HALT mode is now exited.
- H. Normal operation resumes.
- I. From the time the IDLE instruction is executed to place the device into low-power mode (LPM), wakeup should not be initiated until at least 4 OSCCLK cycles have elapsed.

**Figure 5-50. HALT Wake-Up Using GPIO<sub>n</sub>**

## 5.7.5 Emulation and Debug

### 5.7.5.1 Emulator Connection Without Signal Buffering for the F28PLC8x Device

Figure 5-51 shows the connection between the F28PLC8x device and JTAG header for a single-processor configuration. If the distance between the JTAG header and the F28PLC8x device is greater than 6 inches, the emulation signals must be buffered. If the distance is less than 6 inches, buffering is typically not needed. Figure 5-51 shows the simpler, no-buffering situation. For the pullup/pulldown resistor values, see Section 4.1, Terminal Functions.

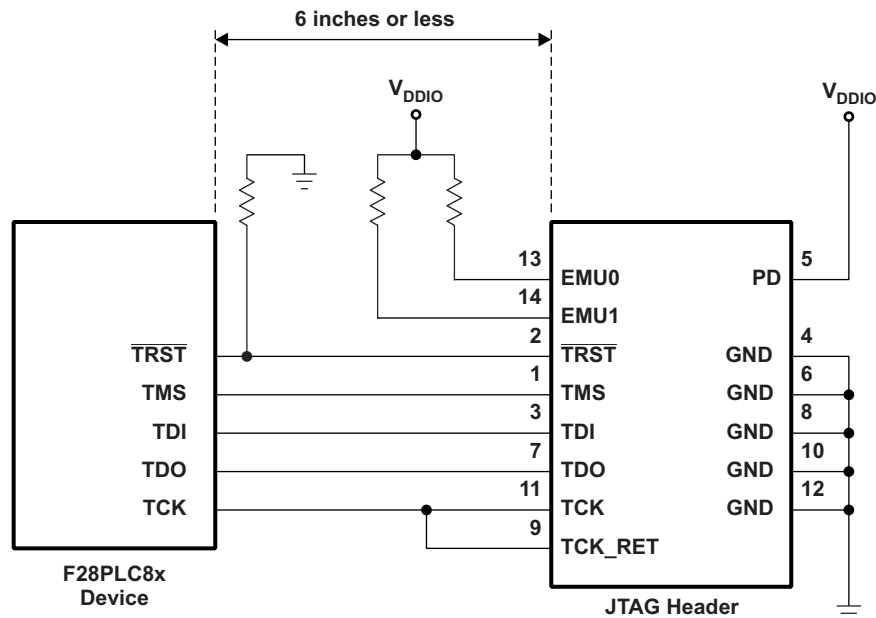

A. See Figure 5-42 for JTAG/GPIO multiplexing.

**Figure 5-51. Emulator Connection Without Signal Buffering for the F28PLC8x Device**

#### NOTE

The F28PLC8x device does not have EMU0/EMU1 pins. For designs that have a JTAG Header on-board, the EMU0/EMU1 pins on the header must be tied to V<sub>DDIO</sub> through a 4.7-k $\Omega$  (typical) resistor.

## 5.8 Current Consumption

**Table 5-65. TMS320F28PLC84, TMS320F28PLC83 Current Consumption at 90-MHz SYSCLKOUT**

MODE	TEST CONDITIONS	VREG ENABLED						VREG DISABLED							
		$I_{DDIO}^{(1)}$		$I_{DDA}^{(2)}$		$I_{DD3VFL}$		$I_{DD}$		$I_{DDIO}^{(1)}$		$I_{DDA}^{(2)}$		$I_{DD3VFL}$	
		TYP <sup>(3)</sup>	MAX	TYP <sup>(3)</sup>	MAX	TYP <sup>(3)</sup>	MAX	TYP <sup>(3)</sup>	MAX	TYP <sup>(3)</sup>	MAX	TYP <sup>(3)</sup>	MAX	TYP <sup>(3)</sup>	MAX
Operational (Flash)	The following peripheral clocks are enabled: <ul style="list-style-type: none"> <li>ePWM1, ePWM2</li> <li>eCAP1</li> <li>HRPWM</li> <li>SCI-A, SCI-B</li> <li>SPI-A, SPI-B</li> <li>ADC</li> <li>I<sup>2</sup>C</li> <li>COMP1, COMP2, COMP3</li> <li>CPU-TIMER0, CPU-TIMER1, CPU-TIMER2</li> <li>McBSP</li> </ul> All PWM pins are toggled at 60 kHz. All I/O pins are left unconnected. <sup>(4)</sup> Code is running out of flash with 2 wait-states. XCLKOUT is turned off.	230 mA		16 mA	22 mA	25 mA		220 mA		20 mA		16 mA	22 mA	25 mA	
IDLE	Flash is powered down. XCLKOUT is turned off. All peripheral clocks are turned off.	22 mA	27 mA	15 $\mu$ A	25 $\mu$ A	5 $\mu$ A	10 $\mu$ A	21 mA	26 mA	120 $\mu$ A	400 $\mu$ A	15 $\mu$ A	25 $\mu$ A	5 $\mu$ A	10 $\mu$ A
STANDBY	Flash is powered down. Peripheral clocks are off.	9 mA	11 mA	15 $\mu$ A	25 $\mu$ A	5 $\mu$ A	10 $\mu$ A	8 mA	10 mA	120 $\mu$ A	400 $\mu$ A	15 $\mu$ A	25 $\mu$ A	5 $\mu$ A	10 $\mu$ A
HALT	Flash is powered down. Peripheral clocks are off. Input clock is disabled. <sup>(5)</sup>	75 $\mu$ A		15 $\mu$ A	25 $\mu$ A	5 $\mu$ A	10 $\mu$ A	25 $\mu$ A <sup>(6)</sup>		40 $\mu$ A		15 $\mu$ A	25 $\mu$ A	5 $\mu$ A	10 $\mu$ A

- $I_{DDIO}$  current is dependent on the electrical loading on the I/O pins.
- In order to realize the  $I_{DDA}$  currents shown for IDLE, STANDBY, and HALT, clock to the ADC module must be turned off explicitly by writing to the PCLKCR0 register.
- The TYP numbers are applicable over room temperature and nominal voltage.
- The following is done in a loop:
  - Data is continuously transmitted out of SPI-A, SPI-B, SCI-A, McBSP-A, and I<sup>2</sup>C ports.
  - The hardware multiplier is exercised.
  - Watchdog is reset.
  - ADC is performing continuous conversion.
  - COMP1 and COMP2 are continuously switching voltages.
  - GPIO17 is toggled.
- If a quartz crystal or ceramic resonator is used as the clock source, the HALT mode shuts down the on-chip crystal oscillator.
- To realize the  $I_{DD}$  number shown for HALT mode, the following must be done:
  - PLL2 must be shut down by clearing bit 2 of the PLLCTL register.
  - A value of 0x00FF must be written to address 0x6822.

### NOTE

The peripheral-I/O multiplexing implemented in the device prevents all available peripherals from being used at the same time because more than one peripheral function may share an I/O pin. It is, however, possible to turn on the clocks to all the peripherals at the same time, although such a configuration is not useful. If the clocks to all the peripherals are turned on at the same time, the current drawn by the device will be more than the numbers specified in the current consumption tables.

### 5.8.1 Reducing Current Consumption

The F28PLC8x device incorporates a method to reduce the device current consumption. Since each peripheral unit has an individual clock-enable bit, significant reduction in current consumption can be achieved by turning off the clock to any peripheral module that is not used in a given application. Furthermore, any one of the three low-power modes could be taken advantage of to reduce the current consumption even further. [Table 5-66](#) indicates the typical reduction in current consumption achieved by turning off the clocks.

**Table 5-66. Typical Current Consumption by Various Peripherals (at 90 MHz)<sup>(1)</sup>**

PERIPHERAL MODULE <sup>(2)</sup>	I <sub>DD</sub> CURRENT REDUCTION (mA)
ADC	2 <sup>(3)</sup>
I <sup>2</sup> C	3
ePWM	2
eCAP	2
SCI	2
SPI	2
COMP/DAC	1
HRPWM	3
CPU-TIMER	1
Internal zero-pin oscillator	0.5
McBSP	6

- (1) All peripheral clocks (except CPU Timer clock) are disabled upon reset. Writing to/reading from peripheral registers is possible only after the peripheral clocks are turned on.
- (2) For peripherals with multiple instances, the current quoted is per module. For example, the 2 mA value quoted for ePWM is for one ePWM module.
- (3) This number represents the current drawn by the digital portion of the ADC module. Turning off the clock to the ADC module results in the elimination of the current drawn by the analog portion of the ADC (I<sub>DDA</sub>) as well.

---

#### NOTE

I<sub>DDIO</sub> current consumption is reduced by 15 mA (typical) when XCLKOUT is turned off.

---

#### NOTE

The baseline I<sub>DD</sub> current (current when the core is executing a dummy loop with no peripherals enabled) is 40 mA, typical. To arrive at the I<sub>DD</sub> current for a given application, the current-drawn by the peripherals (enabled by that application) must be added to the baseline I<sub>DD</sub> current.

---

Following are other methods to reduce power consumption further:

- The flash module may be powered down if code is run off SARAM. This method results in a current reduction of 18 mA (typical) in the V<sub>DD</sub> rail and 13 mA (typical) in the V<sub>DDIO</sub> rail.
- Savings in I<sub>DDIO</sub> may be realized by disabling the pullups on pins that assume an output function.

5.8.2 Current Consumption Graphs (VREG Enabled)

Operational Current (Flash) vs Frequency (Internal VREG)

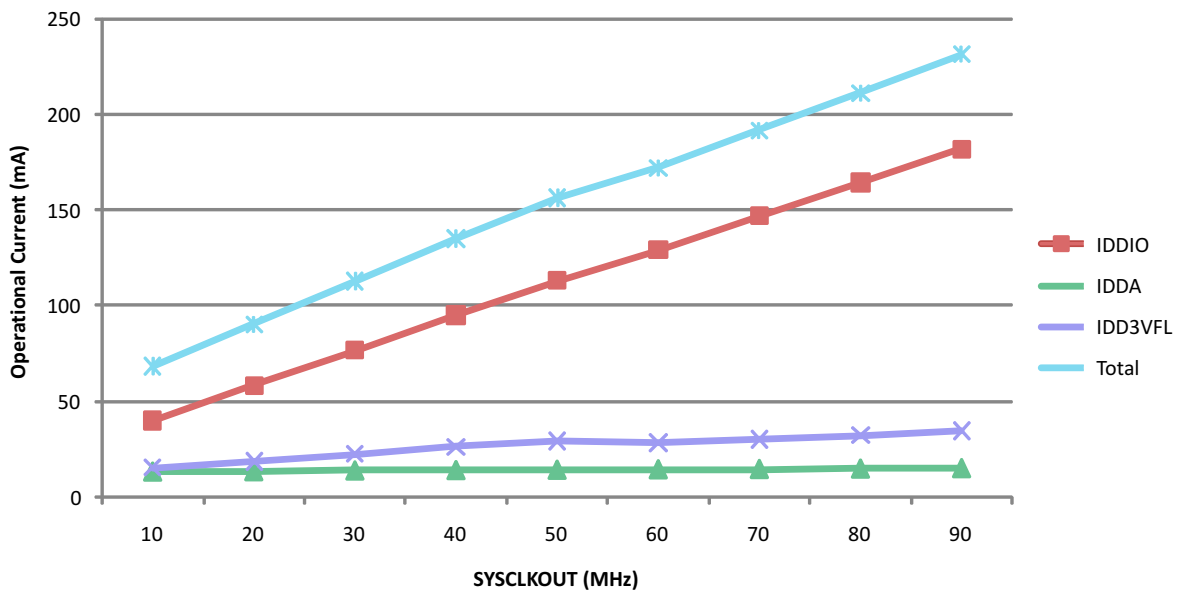

Figure 5-52. Typical Operational Current Versus Frequency

Operational Power vs Frequency (Internal VREG)

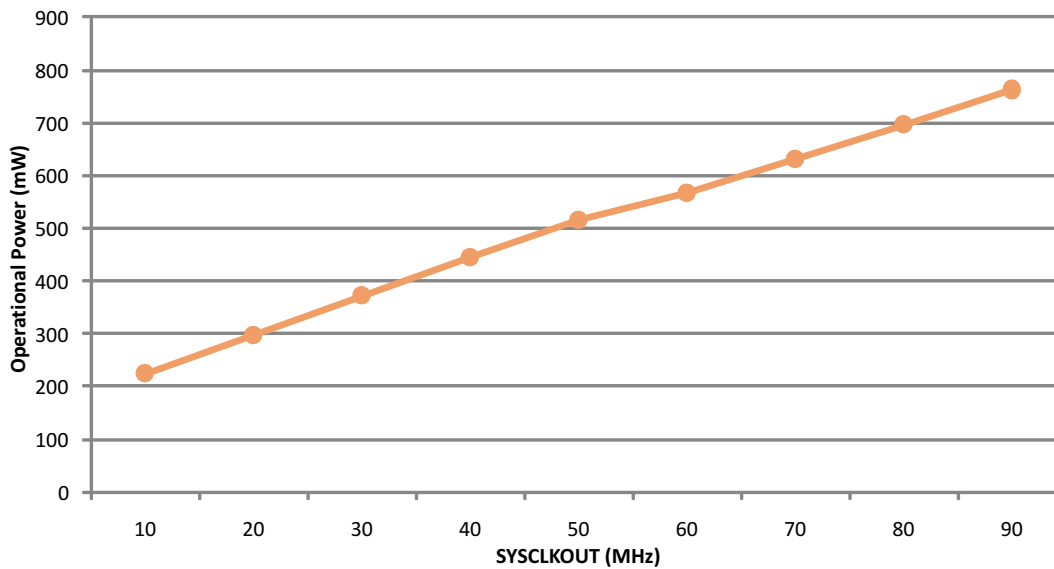

Figure 5-53. Typical Operational Power Versus Frequency

## 5.9 Parameter Information

### 5.9.1 Timing Parameter Symbology

Timing parameter symbols used are created in accordance with JEDEC Standard 100. To shorten the symbols, some of the pin names and other related terminology have been abbreviated as follows:

Lowercase subscripts and their meanings:		Letters and symbols and their meanings:	
a	access time	H	High
c	cycle time (period)	L	Low
d	delay time	V	Valid
f	fall time	X	Unknown, changing, or don't care level
h	hold time	Z	High impedance
r	rise time		
su	setup time		
t	transition time		
v	valid time		
w	pulse duration (width)		

### 5.9.2 General Notes on Timing Parameters

All output signals from the 28x devices (including XCLKOUT) are derived from an internal clock such that all output transitions for a given half-cycle occur with a minimum of skewing relative to each other.

The signal combinations shown in the following timing diagrams may not necessarily represent actual cycles. For actual cycle examples, see the appropriate cycle description section of this document.

## 5.10 Test Load Circuit

This test load circuit is used to measure all switching characteristics provided in this document.

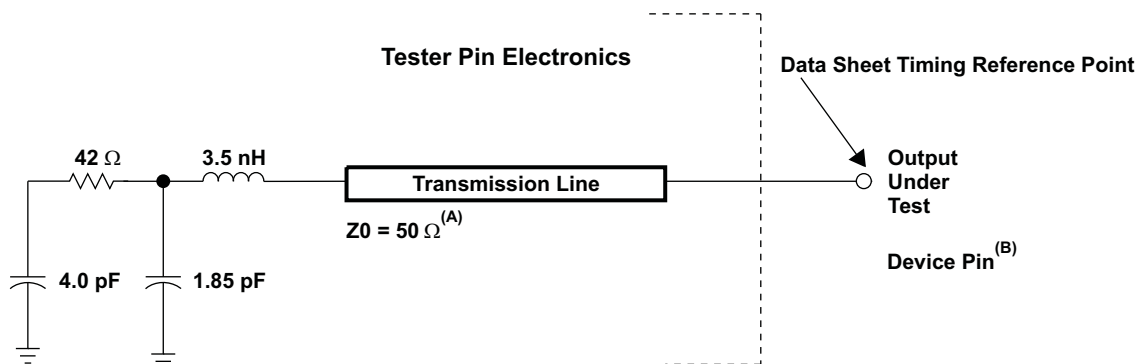

- Input requirements in this data sheet are tested with an input slew rate of < 4 Volts per nanosecond (4 V/ns) at the device pin.
- The data sheet provides timing at the device pin. For output timing analysis, the tester pin electronics and its transmission line effects must be taken into account. A transmission line with a delay of 2 ns or longer can be used to produce the desired transmission line effect. The transmission line is intended as a load only. It is not necessary to add or subtract the transmission line delay (2 ns or longer) from the data sheet timing.

Figure 5-54. 3.3-V Test Load Circuit

## 5.11 Flash Timing

**Table 5-67. Flash/OTP Endurance for T Temperature Material<sup>(1)</sup>**

		ERASE/PROGRAM TEMPERATURE	MIN	TYP	MAX	UNIT
$N_f$	Flash endurance for the array (write/erase cycles)	0°C to 105°C (ambient)	20000	50000		cycles
$N_{OTP}$	OTP endurance for the array (write cycles)	0°C to 30°C (ambient)			1	write

(1) Write/erase operations outside of the temperature ranges indicated are not specified and may affect the endurance numbers.

**Table 5-68. Flash Parameters at 90-MHz SYSCLKOUT**

PARAMETER		TEST CONDITIONS	MIN	TYP	MAX	UNIT
Program Time	16-Bit Word			50		μs
	16K Sector			500		ms
	8K Sector			250		ms
	4K Sector			125		ms
Erase Time <sup>(1)</sup>	16K Sector			2		s
	8K Sector			2		s
	4K Sector			2		s
$I_{DDP}$ <sup>(2)</sup>	$V_{DD}$ current consumption during Erase/Program cycle	VREG disabled		80		mA
$I_{DDIOP}$ <sup>(2)</sup>	$V_{DDIO}$ current consumption during Erase/Program cycle			60		
$I_{DDIOP}$ <sup>(2)</sup>	$V_{DDIO}$ current consumption during Erase/Program cycle	VREG enabled		120		mA

- (1) The on-chip flash memory is in an erased state when the device is shipped from TI. As such, erasing the flash memory is not required prior to programming, when programming the device for the first time. However, the erase operation is needed on all subsequent programming operations.
- (2) Typical parameters as seen at room temperature including function call overhead, with all peripherals off. It is important to maintain a stable power supply during the entire flash programming process. It is conceivable that device current consumption during flash programming could be higher than normal operating conditions. The power supply used should ensure  $V_{MIN}$  on the supply rails at all times, as specified in the Recommended Operating Conditions of the data sheet. Any brown-out or interruption to power during erasing/programming could potentially corrupt the password locations and lock the device permanently.

**Table 5-69. Flash/OTP Access Timing<sup>(1)</sup>**

PARAMETER		MIN	MAX	UNIT
$t_{a(fp)}$	Paged Flash access time	36		ns
$t_{a(fr)}$	Random Flash access time	36		ns
$t_{a(OTP)}$	OTP access time	60		ns

(1) Access time numbers shown in this table are prior to device characterization. Final numbers will be published in the TMS datasheet.

**Table 5-70. Flash Data Retention Duration**

PARAMETER		TEST CONDITIONS	MIN	MAX	UNIT
$t_{retention}$	Data retention duration	$T_J = 55^\circ\text{C}$	15		years

**Table 5-71. Minimum Required Flash/OTP Wait-States at Different Frequencies**

SYCLKOUT (MHz)	SYCLKOUT (ns)	PAGE WAIT-STATE <sup>(1)</sup>	RANDOM WAIT-STATE <sup>(1)</sup>	OTP WAIT-STATE
90	11.11	3	3	5
80	12.5	2	2	4
70	14.29	2	2	4
60	16.67	2	2	3
55	18.18	1	1	3
50	20	1	1	2
45	22.22	1	1	2
40	25	1	1	2
35	28.57	1	1	2
30	33.33	1	1	1

(1) Page and random wait-state must be  $\geq 1$ .

The equations to compute the Flash page wait-state and random wait-state in [Table 5-71](#) are as follows:

$$\text{Flash Page Wait State} = \left\lceil \left( \frac{t_{a(f.p)}}{t_{c(SCO)}} \right) - 1 \right\rceil \text{ round up to the next highest integer, or 1, whichever is larger}$$

$$\text{Flash Random Wait State} = \left\lceil \left( \frac{t_{a(f.r)}}{t_{c(SCO)}} \right) - 1 \right\rceil \text{ round up to the next highest integer, or 1, whichever is larger}$$

The equation to compute the OTP wait-state in [Table 5-71](#) is as follows:

$$\text{OTP Wait State} = \left\lceil \left( \frac{t_{a(OTP)}}{t_{c(SCO)}} \right) - 1 \right\rceil \text{ round up to the next highest integer, or 1, whichever is larger}$$

## 6 Detailed Description

### 6.1 Overview

#### 6.1.1 CPU

The TMS320F28PLCx (C28x) family is a member of the TMS320C2000™ MCU platform. The C28x-based controllers have the same 32-bit fixed-point architecture as existing C28x MCUs. Each C28x-based controller, including the TMS320F28PLC8x device, is a very efficient C/C++ engine, enabling users to develop not only their system control software in a high-level language, but also enabling development of math algorithms using C/C++. The device is equally efficient at MCU math tasks and at system control tasks. This efficiency removes the need for a second processor in many systems. The 32 x 32-bit multiply-and-accumulate (MAC) 64-bit processing capabilities enable the controller to handle higher numerical resolution problems efficiently. Add to this feature the fast interrupt response with automatic context save of critical registers, resulting in a device that is capable of servicing many asynchronous events with minimal latency. The device has an 8-level-deep protected pipeline with pipelined memory accesses. This pipelining enables the device to execute at high speeds without resorting to expensive high-speed memories. Special branch-look-ahead hardware minimizes the latency for conditional discontinuities. Special store conditional operations further improve performance.

#### 6.1.2 Viterbi, Complex Math, CRC Unit

The C28x VCU enhances the processing power of C2000™ devices by adding additional assembly instructions to target complex math, Viterbi decode, and Cyclic Redundancy Check (CRC) calculations. The VCU instructions accelerate many applications, including the following:

- OFDM used in the PRIME and G3 standards for power line communications
- Short-range radar complex math calculations
- Power calculations
- Memory and data communication packet checks (CRC)

The VCU features include:

- Instructions to support Cyclic Redundancy Checks, which is a polynomial code checksum.
  - CRC8
  - CRC16
  - CRC32
- Instructions to support a flexible software implementation of a Viterbi decoder
  - Branch metric calculations for a code rate of 1/2 or 1/3
  - Add-Compare Select or Viterbi Butterfly in 5 cycles per butterfly
  - Traceback in 3 cycles per stage
  - Easily supports a constraint length of  $K = 7$  used in PRIME and G3 standards
- Complex math arithmetic unit
  - Single-cycle Add or Subtract
  - 2-cycle multiply
  - 2-cycle MAC
  - Single-cycle repeat MAC
- Independent register space

### 6.1.3 Memory Bus (Harvard Bus Architecture)

As with many MCU-type devices, multiple busses are used to move data between the memories and peripherals and the CPU. The memory bus architecture contains a program read bus, data read bus, and data write bus. The program read bus consists of 22 address lines and 32 data lines. The data read and write busses consist of 32 address lines and 32 data lines each. The 32-bit-wide data busses enable single cycle 32-bit operations. The multiple bus architecture, commonly termed Harvard Bus, enables the C28x to fetch an instruction, read a data value and write a data value in a single cycle. All peripherals and memories attached to the memory bus prioritize memory accesses. Generally, the priority of memory bus accesses can be summarized as follows:

Highest:	Data Writes	(Simultaneous data and program writes cannot occur on the memory bus.)
	Program Writes	(Simultaneous data and program writes cannot occur on the memory bus.)
	Data Reads	
	Program Reads	(Simultaneous program reads and fetches cannot occur on the memory bus.)
Lowest:	Fetches	(Simultaneous program reads and fetches cannot occur on the memory bus.)

### 6.1.4 Peripheral Bus

To enable migration of peripherals between various Texas Instruments (TI) MCU family of devices, the device adopts a peripheral bus standard for peripheral interconnect. The peripheral bus bridge multiplexes the various busses that make up the processor Memory Bus into a single bus consisting of 16 address lines and 16 or 32 data lines and associated control signals. Three versions of the peripheral bus are supported. One version supports only 16-bit accesses (called peripheral frame 2). Another version supports both 16- and 32-bit accesses (called peripheral frame 1).

### 6.1.5 Real-Time JTAG and Analysis

The device implements the standard IEEE 1149.1 JTAG <sup>(1)</sup> interface for in-circuit based debug. Additionally, the device supports real-time mode of operation allowing modification of the contents of memory, peripheral, and register locations while the processor is running and executing code and servicing interrupts. The user can also single step through non-time-critical code while enabling time-critical interrupts to be serviced without interference. The device implements the real-time mode in hardware within the CPU. This feature is unique to the 28x family of devices, and requires no software monitor. Additionally, special analysis hardware is provided that allows setting of hardware breakpoint or data/address watch-points and generating various user-selectable break events when a match occurs. This device does not support boundary scan; however, IDCODE and BYPASS features are available if the following considerations are taken into account. The IDCODE does not come by default. The user needs to go through a sequence of SHIFT IR and SHIFT DR state of JTAG to get the IDCODE. For BYPASS instruction, the first shifted DR value would be 1.

(1) IEEE Standard 1149.1-1990 Standard Test Access Port and Boundary Scan Architecture

### 6.1.6 Flash

The F28PLC8x device contains 128K x 16 of embedded flash memory, segregated into eight 16K x 16 sectors. The device also contains a single 1K x 16 of OTP memory at address range 0x3D 7800 – 0x3D 7BF9. The user can individually erase, program, and validate a flash sector while leaving other sectors untouched. However, it is not possible to use one sector of the flash or the OTP to execute flash algorithms that erase/program other sectors. Special memory pipelining is provided to enable the flash module to achieve higher performance. The flash/OTP is mapped to both program and data space; therefore, the flash/OTP can be used to execute code or store data information. Addresses 0x3F 7FF0 – 0x3F 7FF5 are reserved for data variables and should not contain program code.

#### NOTE

The Flash and OTP wait-states can be configured by the application. This feature allows applications running at slower frequencies to configure the flash to use fewer wait-states.

Flash effective performance can be improved by enabling the flash pipeline mode in the Flash options register. With this mode enabled, effective performance of linear code execution will be much faster than the raw performance indicated by the wait-state configuration alone. The exact performance gain when using the Flash pipeline mode is application-dependent.

### 6.1.7 M0, M1 SARAMs

The device contains these two blocks of single-access memory, each 1K x 16 in size. The stack pointer points to the beginning of block M1 on reset. The M0 and M1 blocks, like all other memory blocks on C28x devices, are mapped to both program and data space. Hence, the user can use M0 and M1 to execute code or for data variables. The partitioning is performed within the linker. The C28x device presents a unified memory map to the programmer, which makes for easier programming in high-level languages.

### 6.1.8 L4 SARAM, and L0, L1, L2, L3, L5, L6, L7, and L8 DPSARAMs

The device contains 48K x 16 of single-access RAM. This block is mapped to both program and data space. L0 is 2K in size. L1 and L2 are each 1K in size. L3 is 4K in size. L4, L5, L6, L7, and L8 are each 8K in size. L5, L6, L7, and L8 are shared with the DMA, which can utilize these blocks for its data space. See [Figure 6-5](#). DPSARAM refers to the dual-port configuration of these blocks.

### 6.1.9 Boot ROM

The Boot ROM is factory-programmed with boot-loading software. Boot-mode signals are provided to tell the bootloader software what boot mode to use on power up. The user can select to boot normally or to download new software from an external connection or to select boot software that is programmed in the internal Flash/ROM. The Boot ROM also contains standard tables, such as SIN/COS waveforms, for use in math-related algorithms.

**Table 6-1. Boot Mode Selection**

MODE	GPIO37/TDO	GPIO34/COMP2OUT/ COMP3OUT	$\overline{\text{TRST}}$	MODE
3	1	1	0	GetMode
2	1	0	0	Wait (see <a href="#">Section 6.1.10</a> for description)
1	0	1	0	SCI
0	0	0	0	Parallel IO
EMU	x	x	1	Emulation Boot

### 6.1.9.1 Emulation Boot

When the emulator is connected, the GPIO37/TDO pin cannot be used for boot mode selection. In this case, the boot ROM detects that an emulator is connected and uses the contents of two reserved SARAM locations in the PIE vector table to determine the boot mode. If the content of either location is invalid, then the *Wait* boot option is used. All boot mode options can be accessed in emulation boot.

### 6.1.9.2 GetMode

The default behavior of the *GetMode* option is to boot to flash. This behavior can be changed to another boot option by programming two locations in the OTP. If the content of either OTP location is invalid, then boot to flash is used. One of the following loaders can be specified: SCI, SPI, I<sup>2</sup>C, or OTP.

### 6.1.9.3 Peripheral Pins Used by the Bootloader

Table 6-2 shows which GPIO pins are used by each peripheral bootloader. Refer to the GPIO mux table to see if these conflict with any of the peripherals you would like to use in your application.

**Table 6-2. Peripheral Bootload Pins**

BOOTLOADER	PERIPHERAL LOADER PINS
SCI	SCIRXDA (GPIO28) SCITXDA (GPIO29)
Parallel Boot	Data (GPIO31,30,5:0) 28x Control (AIO6) Host Control (AIO12)
SPI	SPISIMOA (GPIO16) SPISOMIA (GPIO17) SPICLKA (GPIO18) SPISTEA (GPIO19)
I <sup>2</sup> C	SDAA (GPIO32) SCLA (GPIO33)

### 6.1.10 Security

The F28PLC8x device supports high levels of security to protect the user firmware from being reverse-engineered. The security features a 128-bit password (hardcoded for 16 wait-states), which the user programs into the flash. One code security module (CSM) is used to protect the flash/OTP and the L0/L1 SARAM blocks. The security feature prevents unauthorized users from examining the memory contents via the JTAG port, executing code from external memory or trying to boot-load some undesirable software that would export the secure memory contents. To enable access to the secure blocks, the user must write the correct 128-bit KEY value that matches the value stored in the password locations within the Flash.

In addition to the CSM, the emulation code security logic (ECSL) has been implemented to prevent unauthorized users from stepping through secure code. Any code or data access to CSM secure memory while the emulator is connected will trip the ECSL and break the emulation connection. To allow emulation of secure code, while maintaining the CSM protection against secure memory reads, the user must write the correct value into the lower 64 bits of the KEY register, which matches the value stored in the lower 64 bits of the password locations within the flash. Note that dummy reads of all 128 bits of the password in the flash must still be performed. If the lower 64 bits of the password locations are all ones (unprogrammed), then the KEY value does not need to match.

When initially debugging a device with the password locations in flash programmed (that is, secured), the CPU will start running and may execute an instruction that performs an access to a protected ECSL area. If this event occurs, the ECSL will trip and cause the emulator connection to be cut.

The solution is to use the *Wait* boot option. The *Wait* boot option will sit in a loop around a software breakpoint to allow an emulator to be connected without tripping security. The F28PLC8x device does not support a hardware wait-in-reset mode.

---

#### NOTE

- When the code-security passwords are programmed, all addresses between 0x3F 7F80 and 0x3F 7FF5 cannot be used as program code or data. These locations must be programmed to 0x0000.
- If the code security feature is not used, addresses 0x3F 7F80 through 0x3F 7FEF may be used for code or data. Addresses 0x3F 7FF0 – 0x3F 7FF5 are reserved for data and should not contain program code.

The 128-bit password (at 0x3F 7FF8 – 0x3F 7FFF) must not be programmed to zeros. Doing so would permanently lock the device.

---

---

#### Disclaimer

##### Code Security Module Disclaimer

THE CODE SECURITY MODULE (CSM) INCLUDED ON THIS DEVICE WAS DESIGNED TO PASSWORD PROTECT THE DATA STORED IN THE ASSOCIATED MEMORY (EITHER ROM OR FLASH) AND IS WARRANTED BY TEXAS INSTRUMENTS (TI), IN ACCORDANCE WITH ITS STANDARD TERMS AND CONDITIONS, TO CONFORM TO TI'S PUBLISHED SPECIFICATIONS FOR THE WARRANTY PERIOD APPLICABLE FOR THIS DEVICE.

TI DOES NOT, HOWEVER, WARRANT OR REPRESENT THAT THE CSM CANNOT BE COMPROMISED OR BREACHED OR THAT THE DATA STORED IN THE ASSOCIATED MEMORY CANNOT BE ACCESSED THROUGH OTHER MEANS. MOREOVER, EXCEPT AS SET FORTH ABOVE, TI MAKES NO WARRANTIES OR REPRESENTATIONS CONCERNING THE CSM OR OPERATION OF THIS DEVICE, INCLUDING ANY IMPLIED WARRANTIES OF MERCHANTABILITY OR FITNESS FOR A PARTICULAR PURPOSE.

IN NO EVENT SHALL TI BE LIABLE FOR ANY CONSEQUENTIAL, SPECIAL, INDIRECT, INCIDENTAL, OR PUNITIVE DAMAGES, HOWEVER CAUSED, ARISING IN ANY WAY OUT OF YOUR USE OF THE CSM OR THIS DEVICE, WHETHER OR NOT TI HAS BEEN ADVISED OF THE POSSIBILITY OF SUCH DAMAGES. EXCLUDED DAMAGES INCLUDE, BUT ARE NOT LIMITED TO LOSS OF DATA, LOSS OF GOODWILL, LOSS OF USE OR INTERRUPTION OF BUSINESS OR OTHER ECONOMIC LOSS.

---

### 6.1.11 Peripheral Interrupt Expansion Block

The PIE block serves to multiplex numerous interrupt sources into a smaller set of interrupt inputs. The PIE block can support up to 96 peripheral interrupts. On the F28PLCx, 72 of the possible 96 interrupts are used by peripherals. The 96 interrupts are grouped into blocks of 8 and each group is fed into 1 of 12 CPU interrupt lines (INT1 to INT12). Each of the 96 interrupts is supported by its own vector stored in a dedicated RAM block that can be overwritten by the user. The vector is automatically fetched by the CPU on servicing the interrupt. Eight CPU clock cycles are needed to fetch the vector and save critical CPU registers. Hence the CPU can quickly respond to interrupt events. Prioritization of interrupts is controlled in hardware and software. Each individual interrupt can be enabled or disabled within the PIE block.

### 6.1.12 External Interrupts (XINT1–XINT3)

The F28PLC8x device supports three masked external interrupts (XINT1–XINT3). Each of the interrupts can be selected for negative, positive, or both negative and positive edge triggering and can also be enabled or disabled. These interrupts also contain a 16-bit free-running up counter, which is reset to zero when a valid interrupt edge is detected. This counter can be used to accurately time-stamp the interrupt. There are no dedicated pins for the external interrupts. XINT1, XINT2, and XINT3 interrupts can accept inputs from GPIO0–GPIO31 pins.

### 6.1.13 Internal Zero Pin Oscillators, Oscillator, and PLL

The device can be clocked by either of the two internal zero-pin oscillators, an external oscillator, or by a crystal attached to the on-chip oscillator circuit. A PLL is provided supporting up to 16 input-clock-scaling ratios. The PLL ratios can be changed on-the-fly in software, enabling the user to scale back on operating frequency if lower power operation is desired. Refer to [Section 5](#), Electrical Specifications, for timing details. The PLL block can be set in bypass mode.

### 6.1.14 Watchdog

The device contains two watchdogs: CPU-Watchdog that monitors the core and NMI-Watchdog that is a missing clock-detect circuit. The user software must regularly reset the CPU-watchdog counter within a certain time frame; otherwise, the CPU-watchdog generates a reset to the processor. The CPU-watchdog can be disabled if necessary. The NMI-Watchdog engages only in case of a clock failure and can either generate an interrupt or a device reset.

### 6.1.15 Peripheral Clocking

The clocks to each individual peripheral can be enabled or disabled to reduce power consumption when a peripheral is not in use. Additionally, the system clock to the serial ports (except I<sup>2</sup>C) can be scaled relative to the CPU clock.

### 6.1.16 Low-power Modes

The F28PLC8x device is a full static CMOS device. Three low-power modes are provided:

- IDLE:** Places CPU in low-power mode. Peripheral clocks may be turned off selectively and only those peripherals that need to function during IDLE are left operating. An enabled interrupt from an active peripheral or the watchdog timer will wake the processor from IDLE mode.
- STANDBY:** Turns off clock to CPU and peripherals. This mode leaves the oscillator and PLL functional. An external interrupt event will wake the processor and the peripherals. Execution begins on the next valid cycle after detection of the interrupt event
- HALT:** This mode basically shuts down the device and places the device in the lowest possible power-consumption mode. If the internal zero-pin oscillators are used as the clock source, the HALT mode turns them off, by default. To keep these oscillators from shutting down, the INTOSCnHALTI bits in CLKCTL register may be used. The zero-pin oscillators may thus be used to clock the CPU-watchdog in this mode. If the on-chip crystal oscillator is used as the clock source, this oscillator is shut down in this mode. A reset or an external signal (through a GPIO pin) or the CPU-watchdog can wake the device from this mode.

The CPU clock (OSCCLK) and WDCLK should be from the same clock source before attempting to put the device into HALT or STANDBY.

### 6.1.17 Peripheral Frames 0, 1, 2, 3 (PFn)

The device segregates peripherals into four sections. The mapping of peripherals is as follows:

- PF0:
  - PIE: PIE Interrupt Enable and Control Registers Plus PIE Vector Table
  - Flash: Flash Waitstate Registers
  - Timers: CPU-Timers 0, 1, 2 Registers
  - CSM: Code Security Module KEY Registers
  - ADC: ADC Result Registers
- PF1:
  - GPIO: GPIO MUX Configuration and Control Registers
- PF2:
  - SYS: System Control Registers
  - SCI: Serial Communications Interface Control and RX/TX Registers
  - SPI: Serial Port Interface Control and RX/TX Registers
  - ADC: ADC Status, Control, and Configuration Registers
  - I<sup>2</sup>C: Inter-Integrated Circuit Module and Registers
  - XINT: External Interrupt Registers
- PF3:
  - McBSP: Multichannel Buffered Serial Port Registers
  - ePWM: Enhanced Pulse Width Modulator Module and Registers
  - eCAP: Enhanced Capture Module and Registers
  - Comparators: Comparator Modules

### 6.1.18 General-Purpose Input/Output Multiplexer

Most of the peripheral signals are multiplexed with GPIO signals. This muxing enables the user to use a pin as GPIO if the peripheral signal or function is not used. On reset, GPIO pins are configured as inputs. The user can individually program each pin for GPIO mode or peripheral signal mode. For specific inputs, the user can also select the number of input qualification cycles. This selection is to filter unwanted noise glitches. The GPIO signals can also be used to bring the device out of specific low-power modes.

### 6.1.19 32-Bit CPU-Timers (0, 1, 2)

CPU-Timers 0, 1, and 2 are identical 32-bit timers with presetable periods and with 16-bit clock prescaling. The timers have a 32-bit count-down register, which generates an interrupt when the counter reaches zero. The counter is decremented at the CPU clock speed divided by the prescale value setting. When the counter reaches zero, the counter is automatically reloaded with a 32-bit period value.

CPU-Timer 0 is for general use and is connected to the PIE block. CPU-Timer 1 is also for general use and can be connected to INT13 of the CPU. CPU-Timer 2 is reserved for DSP/BIOS™. CPU-Timer 2 is connected to INT14 of the CPU. If DSP/BIOS is not being used, CPU-Timer 2 is available for general use.

CPU-Timer 2 can be clocked by any one of the following:

- SYSCLKOUT (default)
- Internal zero-pin oscillator 1 (INTOSC1)
- Internal zero-pin oscillator 2 (INTSOC2)
- External clock source

### 6.1.20 Control Peripherals

The F28PLC8x device supports the following peripherals that are used for embedded control and communication:

- |             |  |
|-------------|--|
| ePWM:       | The enhanced PWM peripheral supports independent/complementary PWM generation, adjustable dead-band generation for leading/trailing edges, latched/cycle-by-cycle trip mechanism. Some of the PWM pins support the HRPWM high resolution duty and period features. The type 1 module found on the F28PLC8x device also supports increased dead-band resolution, enhanced SOC and interrupt generation, and advanced triggering including trip functions based on comparator outputs. |
| eCAP:       | The enhanced capture peripheral uses a 32-bit time base and registers up to four programmable events in continuous/one-shot capture modes. This peripheral can also be configured to generate an auxiliary PWM signal.   |
| ADC:        | The ADC block is a 12-bit converter. The ADC has 13 single-ended channels pinned out. The ADC also contains two sample-and-hold units for simultaneous sampling.   |
| Comparator: | Each comparator block consists of one analog comparator along with an internal 10-bit reference for supplying one input of the comparator.   |

### 6.1.21 Serial Port Peripherals

The F28PLC8x device supports the following serial communication peripherals:

- SPI:** The SPI is a high-speed, synchronous serial I/O port that allows a serial bit stream of programmed length (one to sixteen bits) to be shifted into and out of the device at a programmable bit-transfer rate. Normally, the SPI is used for communications between the device and external peripherals or another processor. Typical applications include external I/O or peripheral expansion through devices such as shift registers, display drivers, and ADCs. Multi-device communications are supported by the master/slave operation of the SPI. The SPI contains a 4-level receive and transmit FIFO for reducing interrupt servicing overhead.
- SCI:** The serial communications interface is a two-wire asynchronous serial port, commonly known as UART. The SCI contains a 4-level receive and transmit FIFO for reducing interrupt servicing overhead.
- I<sup>2</sup>C:** The inter-integrated circuit module provides an interface between a device and other devices compliant with Philips Semiconductors Inter-IC bus (I<sup>2</sup>C-bus) specification version 2.1 and connected by way of an I<sup>2</sup>C-bus. External components attached to this 2-wire serial bus can transmit and receive up to 8-bit data to and from the device through the I<sup>2</sup>C module. The I<sup>2</sup>C contains a 4-level receive-and-transmit FIFO for reducing interrupt servicing overhead.
- McBSP:** The multichannel buffered serial port connects to E1/T1 lines, phone-quality codecs for modem applications or high-quality stereo audio DAC devices. The McBSP receive and transmit registers are supported by the DMA to significantly reduce the overhead for servicing this peripheral. Each McBSP module can be configured as an SPI as required.

## 6.1.22 VREG, BOR, POR

Although the core and I/O circuitry operate on two different voltages, the F28PLC8x device has an on-chip voltage regulator (VREG) to generate the  $V_{DD}$  voltage from the  $V_{DDIO}$  supply. This feature eliminates the cost and space of a second external regulator on an application board. Additionally, internal power-on reset (POR) and brown-out reset (BOR) circuits monitor both the  $V_{DD}$  and  $V_{DDIO}$  rails during power-up and run mode.

### 6.1.22.1 On-chip Voltage Regulator

A linear regulator generates the core voltage ( $V_{DD}$ ) from the  $V_{DDIO}$  supply. Therefore, although capacitors are required on each  $V_{DD}$  pin to stabilize the generated voltage, power need not be supplied to these pins to operate the device. Conversely, the VREG can be disabled, should power or redundancy be the primary concern of the application.

#### 6.1.22.1.1 Using the On-chip VREG

To utilize the on-chip VREG, the  $\overline{VREGENZ}$  pin should be tied low and the appropriate recommended operating voltage should be supplied to the  $V_{DDIO}$  and  $V_{DDA}$  pins. In this case, the  $V_{DD}$  voltage needed by the core logic will be generated by the VREG. Each  $V_{DD}$  pin requires on the order of 1.2  $\mu\text{F}$  (minimum) capacitance for proper regulation of the VREG. These capacitors should be located as close as possible to the  $V_{DD}$  pins.

#### 6.1.22.1.2 Disabling the On-chip VREG

To conserve power, it is also possible to disable the on-chip VREG and supply the core logic voltage to the  $V_{DD}$  pins with a more efficient external regulator. To enable this option, the  $\overline{VREGENZ}$  pin must be tied high.

### 6.1.22.2 On-chip Power-On Reset and Brown-Out Reset Circuit

Two on-chip supervisory circuits, the POR and the BOR remove the burden of monitoring the  $V_{DD}$  and  $V_{DDIO}$  supply rails from the application board. The purpose of the POR is to create a clean reset throughout the device during the entire power-up procedure. The trip point is a looser, lower trip point than the BOR, which watches for dips in the  $V_{DD}$  or  $V_{DDIO}$  rail during device operation. The POR function is present on both  $V_{DD}$  and  $V_{DDIO}$  rails at all times. After initial device power-up, the BOR function is present on  $V_{DDIO}$  at all times, and on  $V_{DD}$  when the internal VREG is enabled ( $\overline{VREGENZ}$  pin is tied low). Both functions tie the  $\overline{XRS}$  pin low when one of the voltages is below their respective trip point. Additionally, when the internal voltage regulator is enabled, an over-voltage protection circuit will tie  $\overline{XRS}$  low if the  $V_{DD}$  rail rises above its trip point. See [Section 5](#) for the various trip points as well as the delay time for the device to release the  $\overline{XRS}$  pin after the under/over-voltage condition is removed. [Figure 6-1](#) shows the VREG, POR, and BOR. To disable both the  $V_{DD}$  and  $V_{DDIO}$  BOR functions, a bit is provided in the BORCFG register.



### 6.1.23 Interrupts

Figure 6-2 shows how the various interrupt sources are multiplexed.

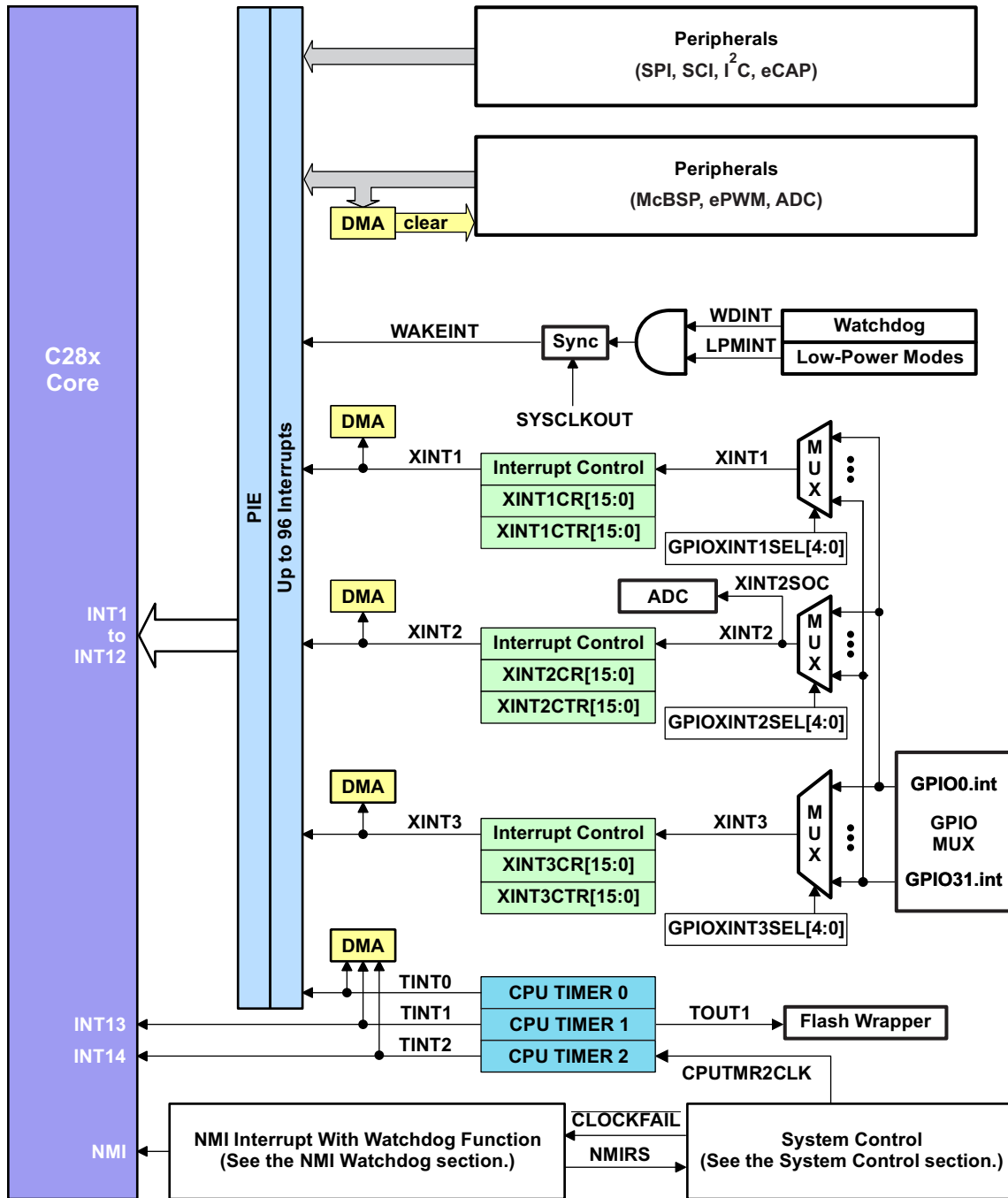

Figure 6-2. External and PIE Interrupt Sources

Eight PIE block interrupts are grouped into one CPU interrupt. In total, 12 CPU interrupt groups, with 8 interrupts per group equals 96 possible interrupts. Table 6-3 shows the interrupts used by the F28PLC8x device.

The TRAP #VectorNumber instruction transfers program control to the interrupt service routine corresponding to the vector specified. TRAP #0 attempts to transfer program control to the address pointed to by the reset vector. The PIE vector table does not, however, include a reset vector. Therefore, TRAP #0 should not be used when the PIE is enabled. Doing so will result in undefined behavior.

When the PIE is enabled, TRAP #1 through TRAP #12 will transfer program control to the interrupt service routine corresponding to the first vector within the PIE group. For example: TRAP #1 fetches the vector from INT1.1, TRAP #2 fetches the vector from INT2.1, and so forth.

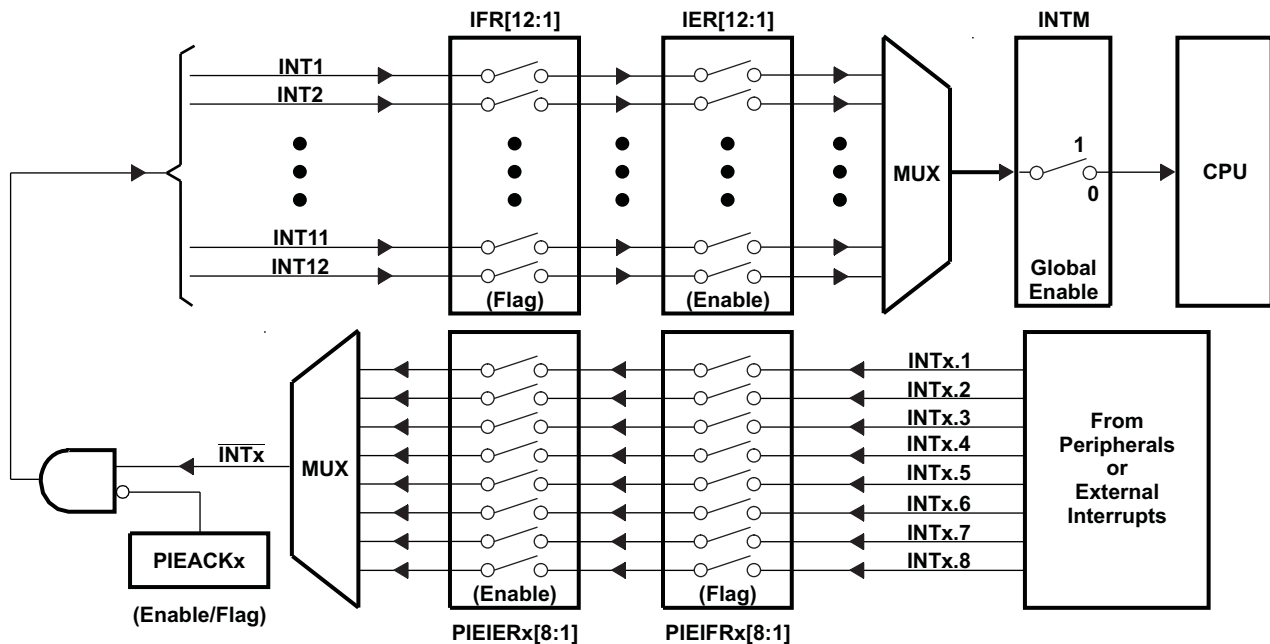

Figure 6-3. Multiplexing of Interrupts Using the PIE Block

**Table 6-3. PIE MUXed Peripheral Interrupt Vector Table<sup>(1)</sup>**

	INTx.8	INTx.7	INTx.6	INTx.5	INTx.4	INTx.3	INTx.2	INTx.1
INT1.y	WAKEINT (LPM/WD) 0xD4E	TINT0 (TIMER 0) 0xD4C	ADCINT9 (ADC) 0xD4A	XINT2 Ext. int. 2 0xD48	XINT1 Ext. int. 1 0xD46	Reserved – 0xD44	ADCINT2 (ADC) 0xD42	ADCINT1 (ADC) 0xD40
INT2.y	Reserved – 0xD5E	Reserved – 0xD5C	Reserved – 0xD5A	Reserved – 0xD58	Reserved – 0xD56	Reserved – 0xD54	EPWM2_TZINT (ePWM2) 0xD52	EPWM1_TZINT (ePWM1) 0xD50
INT3.y	Reserved – 0xD6E	Reserved – 0xD6C	Reserved – 0xD6A	Reserved – 0xD68	Reserved – 0xD66	Reserved – 0xD64	EPWM2_INT (ePWM2) 0xD62	EPWM1_INT (ePWM1) 0xD60
INT4.y	Reserved – 0xD7E	Reserved – 0xD7C	Reserved – 0xD7A	Reserved – 0xD78	Reserved – 0xD76	Reserved – 0xD74	Reserved – 0xD72	ECAP1_INT (eCAP1) 0xD70
INT5.y	Reserved – 0xD8E	Reserved – 0xD8C	Reserved – 0xD8A	Reserved – 0xD88	Reserved – 0xD86	Reserved – 0xD84	Reserved – 0xD82	Reserved – 0xD80
INT6.y	Reserved – 0xD9E	Reserved – 0xD9C	MXINTA (McBSP-A) 0xD9A	MRINTA (McBSP-A) 0xD98	SPITXINTB (SPI-B) 0xD96	SPIRXINTB (SPI-B) 0xD94	SPITXINTA (SPI-A) 0xD92	SPIRXINTA (SPI-A) 0xD90
INT7.y	Reserved – 0xDAE	Reserved – 0xDAC	DINTCH6 (DMA) 0xDAA	DINTCH5 (DMA) 0xDA8	DINTCH4 (DMA) 0xDA6	DINTCH3 (DMA) 0xDA4	DINTCH2 (DMA) 0xDA2	DINTCH1 (DMA) 0xDA0
INT8.y	Reserved – 0xDBE	Reserved – 0xDBC	Reserved – 0xDBA	Reserved – 0xDB8	Reserved – 0xDB6	Reserved – 0xDB4	I2CINT2A (I2C-A) 0xDB2	I2CINT1A (I2C-A) 0xDB0
INT9.y	Reserved – 0xDCE	Reserved – 0xDCC	Reserved – 0xDCA	Reserved – 0xDC8	SCITXINTB (SCI-B) 0xDC6	SCIRXINTB (SCI-B) 0xDC4	SCITXINTA (SCI-A) 0xDC2	SCIRXINTA (SCI-A) 0xDC0
INT10.y	ADCINT8 (ADC) 0xDDE	ADCINT7 (ADC) 0xDDC	ADCINT6 (ADC) 0xDDA	ADCINT5 (ADC) 0xDD8	ADCINT4 (ADC) 0xDD6	ADCINT3 (ADC) 0xDD4	ADCINT2 (ADC) 0xDD2	ADCINT1 (ADC) 0xDD0
INT11.y	Reserved – 0xDEE	Reserved – 0xDEC	Reserved – 0xDEA	Reserved – 0xDE8	Reserved – 0xDE6	Reserved – 0xDE4	Reserved – 0xDE2	Reserved – 0xDE0
INT12.y	Reserved – 0xDFE	Reserved – 0xDFC	Reserved – 0xDFA	Reserved – 0xDF8	Reserved – 0xDF6	Reserved – 0xDF4	Reserved – 0xDF2	XINT3 Ext. Int. 3 0xDF0

(1) Out of 96 possible interrupts, some interrupts are not used. These interrupts are reserved for future devices. These interrupts can be used as software interrupts if they are enabled at the PIEIFRx level, provided none of the interrupts within the group is being used by a peripheral. Otherwise, interrupts coming in from peripherals may be lost by accidentally clearing their flag while modifying the PIEIFR. To summarize, there are two safe cases when the reserved interrupts could be used as software interrupts:

- No peripheral within the group is asserting interrupts.
- No peripheral interrupts are assigned to the group (for example, PIE group 7).

**Table 6-4. PIE Configuration and Control Registers**

NAME	ADDRESS	SIZE (x16)	DESCRIPTION <sup>(1)</sup>
PIECTRL	0x0CE0	1	PIE, Control Register
PIEACK	0x0CE1	1	PIE, Acknowledge Register
PIEIER1	0x0CE2	1	PIE, INT1 Group Enable Register
PIEIFR1	0x0CE3	1	PIE, INT1 Group Flag Register
PIEIER2	0x0CE4	1	PIE, INT2 Group Enable Register
PIEIFR2	0x0CE5	1	PIE, INT2 Group Flag Register
PIEIER3	0x0CE6	1	PIE, INT3 Group Enable Register
PIEIFR3	0x0CE7	1	PIE, INT3 Group Flag Register
PIEIER4	0x0CE8	1	PIE, INT4 Group Enable Register
PIEIFR4	0x0CE9	1	PIE, INT4 Group Flag Register
PIEIER5	0x0CEA	1	PIE, INT5 Group Enable Register
PIEIFR5	0x0CEB	1	PIE, INT5 Group Flag Register
PIEIER6	0x0CEC	1	PIE, INT6 Group Enable Register
PIEIFR6	0x0CED	1	PIE, INT6 Group Flag Register
PIEIER7	0x0CEE	1	PIE, INT7 Group Enable Register
PIEIFR7	0x0CEF	1	PIE, INT7 Group Flag Register
PIEIER8	0x0CF0	1	PIE, INT8 Group Enable Register
PIEIFR8	0x0CF1	1	PIE, INT8 Group Flag Register
PIEIER9	0x0CF2	1	PIE, INT9 Group Enable Register
PIEIFR9	0x0CF3	1	PIE, INT9 Group Flag Register
PIEIER10	0x0CF4	1	PIE, INT10 Group Enable Register
PIEIFR10	0x0CF5	1	PIE, INT10 Group Flag Register
PIEIER11	0x0CF6	1	PIE, INT11 Group Enable Register
PIEIFR11	0x0CF7	1	PIE, INT11 Group Flag Register
PIEIER12	0x0CF8	1	PIE, INT12 Group Enable Register
PIEIFR12	0x0CF9	1	PIE, INT12 Group Flag Register
Reserved	0x0CFA – 0x0CFF	6	Reserved

(1) The PIE configuration and control registers are not protected by EALLOW mode. The PIE vector table is protected.

### 6.1.23.1 External Interrupts

**Table 6-5. External Interrupt Registers**

NAME	ADDRESS	SIZE (x16)	DESCRIPTION
XINT1CR	0x00 7070	1	XINT1 configuration register
XINT2CR	0x00 7071	1	XINT2 configuration register
XINT3CR	0x00 7072	1	XINT3 configuration register
XINT1CTR	0x00 7078	1	XINT1 counter register
XINT2CTR	0x00 7079	1	XINT2 counter register
XINT3CTR	0x00 707A	1	XINT3 counter register

Each external interrupt can be enabled, disabled, or qualified using positive, negative, or both positive and negative edge.

#### 6.1.23.1.1 External Interrupt Electrical Data/Timing

**Table 6-6. External Interrupt Timing Requirements<sup>(1)</sup>**

		MIN	MAX	UNIT
$t_{w(INT)}$ <sup>(2)</sup>	Pulse duration, INT input low/high			
	Synchronous	$1t_{c(SCO)}$		cycles
	With qualifier	$1t_{c(SCO)} + t_{w(IQSW)}$		cycles

(1) For an explanation of the input qualifier parameters, see [Table 5-58](#).

(2) This timing is applicable to any GPIO pin configured for ADCSOC functionality.

**Table 6-7. External Interrupt Switching Characteristics<sup>(1)</sup>**

over recommended operating conditions (unless otherwise noted)

PARAMETER	MIN	MAX	UNIT
$t_{d(INT)}$ Delay time, INT low/high to interrupt-vector fetch		$t_{w(IQSW)} + 12t_{c(SCO)}$	cycles

(1) For an explanation of the input qualifier parameters, see [Table 5-58](#).

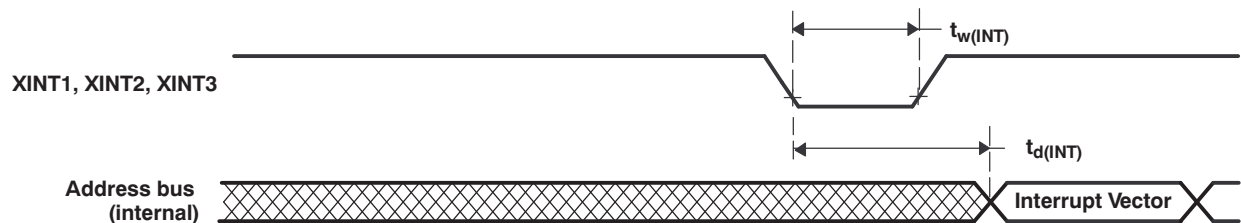

**Figure 6-4. External Interrupt Timing**

## 6.2 Memory

### 6.2.1 Memory Map

In [Figure 6-5](#), the following apply:

- Memory blocks are not to scale.
- Peripheral Frame 0, Peripheral Frame 1, Peripheral Frame 2, and Peripheral Frame 3 memory maps are restricted to data memory only. A user program cannot access these memory maps in program space.
- *Protected* means the order of Write-followed-by-Read operations is preserved rather than the pipeline order.
- Certain memory ranges are EALLOW protected against spurious writes after configuration.
- Locations 0x3D 7C80–0x3D 7CC0 contain the internal oscillator and ADC calibration routines. These locations are not programmable by the user.

	Data Space	Prog Space
0x00 0000	<i>M0 Vector RAM (Enabled if VMAP = 0)</i>	
0x00 0040	M0 SARAM (1K x 16, 0-Wait)	
0x00 0400	M1 SARAM (1K x 16, 0-Wait)	
0x00 0800	Peripheral Frame 0	Reserved
0x00 0D00	PIE Vector - RAM (256 x 16) (Enabled if VMAP = 1, ENPIE = 1)	
0x00 0E00	Peripheral Frame 0	
0x00 1400	Reserved	
0x00 5000	Peripheral Frame 3 (4K x 16, Protected) DMA-Accessible	Reserved
0x00 6000	Peripheral Frame 1 (4K x 16, Protected)	
0x00 7000	Peripheral Frame 2 (4K x 16, Protected)	
0x00 8000	L0 DPSARAM (2K x 16) (0-Wait, Secure Zone + ECSL)	
0x00 8800	L1 DPSARAM (1K x 16) (0-Wait, Secure Zone + ECSL)	
0x00 8C00	L2 DPSARAM (1K x 16) (0-Wait, Secure Zone + ECSL)	
0x00 9000	L3 DPSARAM (4K x 16) (0-Wait, Secure Zone + ECSL)	
0x00 A000	L4 SARAM (8K x 16) (0-Wait, Secure Zone + ECSL)	
0x00 C000	L5 DPSARAM (8K x 16) (0-Wait, DMA RAM 0)	
0x00 E000	L6 DPSARAM (8K x 16) (0-Wait, DMA RAM 1)	
0x01 0000	L7 DPSARAM (8K x 16) (0-Wait, DMA RAM 2)	
0x01 2000	L8 DPSARAM (8K x 16) (0-Wait, DMA RAM 3)	
0x01 4000	Reserved	
0x3D 7800	User OTP (1K x 16, Secure Zone + ECSL)	
0x3D 7BFA	Reserved	
0x3D 7C80	Calibration Data	
0x3D 7CC0	Get_mode function	
0x3D 7CD0	Reserved	
0x3D 7E80	PARTID	
	Calibration Data	
0x3D 7EB0	Reserved	
0x3D 8000	FLASH (128K x 16, 8 Sectors, Secure Zone + ECSL)	
0x3F 7FF8	128-Bit Password	
0x3F 8000	Boot ROM (32K x 16, 0-Wait)	
0x3F FFC0	Vector (32 Vectors, Enabled if VMAP = 1)	

**Figure 6-5. F28PLC8x Memory Map**

**Table 6-8. Addresses of Flash Sectors in F28PLC8x**

ADDRESS RANGE	PROGRAM AND DATA SPACE
0x3D 8000 – 0x3D BFFF	Sector H (16K x 16)
0x3D C000 – 0x3D FFFF	Sector G (16K x 16)
0x3E 0000 – 0x3E 3FFF	Sector F (16K x 16)
0x3E 4000 – 0x3E 7FFF	Sector E (16K x 16)
0x3E 8000 – 0x3E BFFF	Sector D (16K x 16)
0x3E C000 – 0x3E FFFF	Sector C (16K x 16)
0x3F 0000 – 0x3F 3FFF	Sector B (16K x 16)
0x3F 4000 – 0x3F 7FF5	Sector A (16K x 16)
0x3F 7FF6 – 0x3F 7FF7	Boot-to-Flash Entry Point (program branch instruction here)
0x3F 7FF8 – 0x3F 7FFF	Security Password (128-Bit) (Do not program to all zeros)

**NOTE**

Addresses 0x3F 7FF0 – 0x3F 7FF5 are reserved for data and should not contain program code.

Peripheral Frame 1 and Peripheral Frame 2 are grouped together to enable these blocks to be write/read peripheral block protected. The protected mode makes sure that all accesses to these blocks happen as written. Because of the pipeline, a write immediately followed by a read to different memory locations will appear in reverse order on the memory bus of the CPU. This action can cause problems in certain peripheral applications where the user expected the write to occur first (as written). The CPU supports a block protection mode where a region of memory can be protected so that operations occur as written (the penalty is extra cycles are added to align the operations). This mode is programmable, and by default, this mode protects the selected zones.

The wait-states for the various spaces in the memory map area are listed in [Table 6-9](#).

**Table 6-9. Wait-States**

AREA	WAIT-STATES (CPU)	COMMENTS
M0 and M1 SARAMs	0-wait	Fixed
Peripheral Frame 0	0-wait	
Peripheral Frame 1	0-wait (writes) 2-wait (reads)	Cycles can be extended by peripheral-generated ready. Back-to-back write operations to Peripheral Frame 1 registers will incur a 1-cycle stall (1-cycle delay).
Peripheral Frame 2	0-wait (writes) 2-wait (reads)	Fixed. Cycles cannot be extended by the peripheral.
Peripheral Frame 3	0-wait (writes) 2-wait (reads)	Assumes no conflict between CPU and DMA cycles. The wait states can be extended by peripheral-generated ready.
L0–L8 SARAM	0-wait data and program	Assumes no CPU conflicts
OTP	Programmable 1-wait minimum	Programmed via the Flash registers. 1-wait is minimum number of wait states allowed.
FLASH	Programmable 0-wait Paged min 1-wait Random min Random ≥ Paged	Programmed via the Flash registers.
FLASH Password	16-wait fixed	Wait states of password locations are fixed.
Boot-ROM	0-wait	

## 6.2.2 Register Map

The F28PLC8x device contains four peripheral register spaces. The spaces are categorized as follows:

Peripheral Frame 0: These are peripherals that are mapped directly to the CPU memory bus. See [Table 6-10](#).

Peripheral Frame 1: These are peripherals that are mapped to the 32-bit peripheral bus. See [Table 6-11](#).

Peripheral Frame 2: These are peripherals that are mapped to the 16-bit peripheral bus. See [Table 6-12](#).

Peripheral Frame 3: McBSP registers are mapped to this. See [Table 6-13](#).

**Table 6-10. Peripheral Frame 0 Registers<sup>(1)</sup>**

NAME	ADDRESS RANGE	SIZE (x16)	EALLOW PROTECTED <sup>(2)</sup>
Device Emulation Registers	0x00 0880 – 0x00 0984	261	Yes
System Power Control Registers	0x00 0985 – 0x00 0987	3	Yes
FLASH Registers <sup>(3)</sup>	0x00 0A80 – 0x00 0ADF	96	Yes
Code Security Module Registers	0x00 0AE0 – 0x00 0AEF	16	Yes
ADC registers (0 wait read only)	0x00 0B00 – 0x00 0B0F	16	No
CPU-TIMER0, CPU-TIMER1, CPU-TIMER2 Registers	0x00 0C00 – 0x00 0C3F	64	No
PIE Registers	0x00 0CE0 – 0x00 0CFF	32	No
PIE Vector Table	0x00 0D00 – 0x00 0DFF	256	Yes
DMA Registers	0x00 1000 – 0x00 11FF	512	Yes

(1) Registers in Frame 0 support 16-bit and 32-bit accesses.

(2) If registers are EALLOW protected, then writes cannot be performed until the EALLOW instruction is executed. The EDIS instruction disables writes to prevent stray code or pointers from corrupting register contents.

(3) The Flash Registers are also protected by the Code Security Module.

**Table 6-11. Peripheral Frame 1 Registers**

NAME	ADDRESS RANGE	SIZE (x16)	EALLOW PROTECTED
GPIO registers	0x00 6F80 – 0x00 6FFF	128	(1)

(1) Some registers are EALLOW protected.

**Table 6-12. Peripheral Frame 2 Registers**

NAME	ADDRESS RANGE	SIZE (x16)	EALLOW PROTECTED
System Control Registers	0x00 7010 – 0x00 702F	32	Yes
SPI-A Registers	0x00 7040 – 0x00 704F	16	No
SCI-A Registers	0x00 7050 – 0x00 705F	16	No
NMI Watchdog Interrupt Registers	0x00 7060 – 0x00 706F	16	Yes
External Interrupt Registers	0x00 7070 – 0x00 707F	16	Yes
ADC Registers	0x00 7100 – 0x00 717F	128	(1)
SPI-B Registers	0x00 7740 – 0x00 774F	16	No
SCI-B Registers	0x00 7750 – 0x00 775F	16	No
I2C-A Registers	0x00 7900 – 0x00 793F	64	(1)

(1) Some registers are EALLOW protected.

**Table 6-13. Peripheral Frame 3 Registers**

NAME	ADDRESS RANGE	SIZE (x16)	EALLOW PROTECTED
McBSP-A Registers	0x00 5000 – 0x00 503F	64	No
Comparator 1 registers	0x00 6400 – 0x00 641F	32	(1)
Comparator 2 registers	0x00 6420 – 0x00 643F	32	(1)
Comparator 3 registers	0x00 6440 – 0x00 645F	32	(1)
ePWM1 + HRPWM1 registers	0x00 6800 – 0x00 683F	64	(1)
ePWM2 + HRPWM2 registers	0x00 6840 – 0x00 687F	64	(1)
eCAP1 registers	0x00 6A00 – 0x00 6A1F	32	No

(1) Some registers are EALLOW protected.

### 6.3 Identification

These registers are used to control the protection mode of the C28x CPU and to monitor some critical device signals. The registers are defined in [Table 6-14](#).

**Table 6-14. Device Emulation Registers**

NAME	ADDRESS RANGE	SIZE (x16)	DESCRIPTION	EALLOW PROTECTED	
DEVICECNF	0x0880– 0x0881	2	Device Configuration Register	Yes	
PARTID	0x3D 7E80	1	Part ID Register	TMS320F28PLC83PN 0x0083 TMS320F28PLC84PN 0x0081	No
CLASSID	0x0882	1	Class ID Register	TMS320F28PLC83 0x008F TMS320F28PLC84 0x008F	No
REVID	0x0883	1	Revision ID Register	0x0001 - Silicon Rev. A - TMS	No

## 7 Device and Documentation Support

### 7.1 Device Support

#### 7.1.1 Development Support

Texas Instruments (TI) offers an extensive line of development tools for the C28x generation of MCUs, including tools to evaluate the performance of the processors, generate code, develop algorithm implementations, and fully integrate and debug software and hardware modules.

The following products support development of F28PLCx-based applications:

##### Software Development Tools

- Code Composer Studio™ Integrated Development Environment (IDE)
  - C/C++ Compiler
  - Code generation tools
  - Assembler/Linker
  - Cycle Accurate Simulator
- Application algorithms
- Sample applications code

##### Hardware Development Tools

- Development and evaluation boards
- JTAG-based emulators - XDS510™ class, XDS560™ emulator, XDS100
- Flash programming tools
- Power supply
- Documentation and cables

#### 7.1.1.1 Getting Started

This section gives a brief overview of the steps to take when first developing for a C28x device. For more detail on each of these steps, see the following:

- *Getting Started With TMS320C28x Digital Signal Controllers* ([SPRAAM0](#)).
- [C2000 Getting Started Website \(http://www.ti.com/c2000getstarted\)](http://www.ti.com/c2000getstarted)
- TMS320F28x MCU Development and Experimenter's Kits (<http://www.ti.com/f28xkits>)

#### 7.1.1.2 Reference Designs, Starter Kits, and Tools

Several PLC-related TI Designs reference designs are available for download on [www.ti.com](http://www.ti.com). Some of these reference designs are:

- System on Module for PRIME Power Line Communication (CENELEC Frequency Band) ([TIDM-SOMPLC-F28PLC83](#))
- Power Line Communications (PLC) System-on-Module for ARIB Frequency Band ([TIDM-SOMPLC-F28M35](#))
- PLC Motherboard with AC Mains Line Coupling ([TIDA-00192](#))
- Data Concentrator Reference Design ([TIDEP0006](#))

Several PLC evaluation kits are available for purchase on [www.ti.com](http://www.ti.com). Some of these evaluation kits are:

- Power Line Communications Kit for CENELEC Frequency Band ([TMDSPLCKITV4-CEN](#))
- Power Line Communications Kit for ARIB Frequency Band ([TMDSPLCKITV4-ARIB](#))
- Data Concentrator Evaluation Module ([TMDSDC3359](#))

### 7.1.2 Device and Development Support Tool Nomenclature

To designate the stages in the product development cycle, TI assigns prefixes to the part numbers of all TMS320™ MCU devices and support tools. Each TMS320 MCU commercial family member has one of three prefixes: TMX, TMP, or TMS (for example, **TMS320F28PLC83**). Texas Instruments recommends two of three possible prefix designators for its support tools: TMDX and TMDS. These prefixes represent evolutionary stages of product development from engineering prototypes (with TMX for devices and TMDX for tools) through fully qualified production devices and tools (with TMS for devices and TMDS for tools).

Device development evolutionary flow:

- TMX** Experimental device that is not necessarily representative of the final device's electrical specifications
- TMP** Final silicon die that conforms to the device's electrical specifications but has not completed quality and reliability verification
- TMS** Fully qualified production device

Support tool development evolutionary flow:

- TMDX** Development-support product that has not yet completed Texas Instruments internal qualification testing
- TMDS** Fully qualified development-support product

TMX and TMP devices and TMDX development-support tools are shipped against the following disclaimer:

"Developmental product is intended for internal evaluation purposes."

TMS devices and TMDS development-support tools have been characterized fully, and the quality and reliability of the device have been demonstrated fully. TI's standard warranty applies.

Predictions show that prototype devices (TMX or TMP) have a greater failure rate than the standard production devices. Texas Instruments recommends that these devices not be used in any production system because their expected end-use failure rate still is undefined. Only qualified production devices are to be used.

TI device nomenclature also includes a suffix with the device family name. This suffix indicates the package type (for example, PN) and temperature range (for example, T). [Figure 7-1](#) provides a legend for reading the complete device name for any family member.

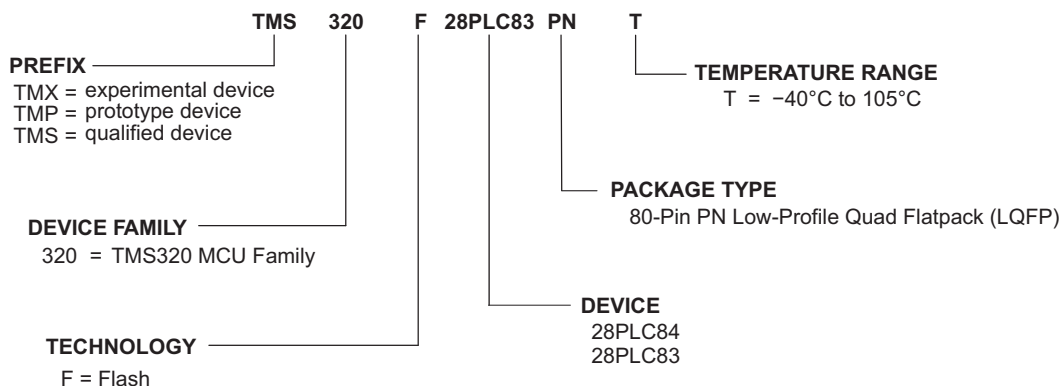

**Figure 7-1. Device Nomenclature**

## 7.2 Documentation Support

Extensive documentation supports all of the TMS320 MCU family generations of devices from product announcement through applications development. The types of documentation available include: data sheets and data manuals, with design specifications; and hardware and software applications.

See the *TMS320x28xx, 28xxx DSP Peripheral Reference Guide* ([SPRU566](#)) for more information on types of peripherals.

The following documents can be downloaded from the TI website ([www.ti.com](#)):

### Data Manual and Errata

[SPRS802](#) **TMS320F28PLC84, TMS320F28PLC83 Power Line Communications (PLC) Processors Data Manual** contains the pinout, signal descriptions, as well as electrical and timing specifications for the F28PLC8x device.

[SPRZ379](#) **TMS320F28PLC84, TMS320F28PLC83 Power Line Communications (PLC) Processors Silicon Errata** describes known advisories on silicon and provides workarounds.

### CPU User's Guides

[SPRU430](#) **TMS320C28x CPU and Instruction Set Reference Guide** describes the central processing unit (CPU) and the assembly language instructions of the TMS320C28x fixed-point digital signal processors (DSPs). This Reference Guide also describes emulation features available on these DSPs.

### Peripheral Guides and Technical Reference Manuals

[SPRU566](#) **TMS320x28xx, 28xxx DSP Peripheral Reference Guide** describes the peripheral reference guides of the 28x digital signal processors (DSPs).

### Tools Guides

[SPRU513](#) **TMS320C28x Assembly Language Tools v6.2.4 User's Guide** describes the assembly language tools (assembler and other tools used to develop assembly language code), assembler directives, macros, common object file format, and symbolic debugging directives for the TMS320C28x device.

[SPRU514](#) **TMS320C28x Optimizing C/C++ Compiler v6.2.4 User's Guide** describes the TMS320C28x C/C++ compiler. This compiler accepts ANSI standard C/C++ source code and produces TMS320 DSP assembly language source code for the TMS320C28x device.

[SPRU608](#) **TMS320C28x Instruction Set Simulator Technical Overview** describes the simulator, available within the Code Composer Studio for TMS320C2000 IDE, that simulates the instruction set of the C28x core.

### Application Reports

[SZZA021](#) **Semiconductor Packing Methodology** describes the packing methodologies employed to prepare semiconductor devices for shipment to end users.

## 7.3 Related Links

The table below lists quick access links. Categories include technical documents, support and community resources, tools and software, and quick access to sample or buy.

**Table 7-1. Related Links**

PARTS	PRODUCT FOLDER	SAMPLE & BUY	TECHNICAL DOCUMENTS	TOOLS & SOFTWARE	SUPPORT & COMMUNITY
TMS320F28PLC84	<a href="#">Click here</a>	<a href="#">Click here</a>	<a href="#">Click here</a>	<a href="#">Click here</a>	<a href="#">Click here</a>
TMS320F28PLC83	<a href="#">Click here</a>	<a href="#">Click here</a>	<a href="#">Click here</a>	<a href="#">Click here</a>	<a href="#">Click here</a>

## 7.4 Community Resources

The following links connect to TI community resources. Linked contents are provided "AS IS" by the respective contributors. They do not constitute TI specifications and do not necessarily reflect TI's views; see TI's [Terms of Use](#).

**[TI E2E™ Online Community](#)** *TI's Engineer-to-Engineer (E2E) Community*. Created to foster collaboration among engineers. At [e2e.ti.com](http://e2e.ti.com), you can ask questions, share knowledge, explore ideas and help solve problems with fellow engineers.

**[TI Embedded Processors Wiki](#)** *Texas Instruments Embedded Processors Wiki*. Established to help developers get started with Embedded Processors from Texas Instruments and to foster innovation and growth of general knowledge about the hardware and software surrounding these devices.

## 7.5 Trademarks

TMS320C2000, C2000, DSP/BIOS, Code Composer Studio, XDS510, XDS560, TMS320, E2E are trademarks of Texas Instruments.

All other trademarks are the property of their respective owners.

## 7.6 Electrostatic Discharge Caution



This integrated circuit can be damaged by ESD. Texas Instruments recommends that all integrated circuits be handled with appropriate precautions. Failure to observe proper handling and installation procedures can cause damage.

ESD damage can range from subtle performance degradation to complete device failure. Precision integrated circuits may be more susceptible to damage because very small parametric changes could cause the device not to meet its published specifications.

## 7.7 Glossary

[SLYZ022](#) — *TI Glossary*.

This glossary lists and explains terms, acronyms, and definitions.

## 8 Mechanical Packaging and Orderable Information

### 8.1 Packaging Information

The following pages include mechanical packaging and orderable information. This information is the most current data available for the designated devices. This data is subject to change without notice and revision of this document. For browser-based versions of this data sheet, refer to the left-hand navigation.

**PACKAGING INFORMATION**

Orderable Device	Status (1)	Package Type	Package Drawing	Pins	Package Qty	Eco Plan (2)	Lead/Ball Finish (6)	MSL Peak Temp (3)	Op Temp (°C)	Device Marking (4/5)	Samples
TMS320F28PLC83PNT	NRND	LQFP	PN	80	119	Green (RoHS & no Sb/Br)	CU NIPDAU	Level-3-260C-168 HR	-40 to 105	F28PLC83PNT TMS320	
TMS320F28PLC83PNTR	NRND	LQFP	PN	80	1000	Green (RoHS & no Sb/Br)	CU NIPDAU	Level-3-260C-168 HR	-40 to 105	F28PLC83PNT TMS320	
TMS320F28PLC84PNT	NRND	LQFP	PN	80	119	Green (RoHS & no Sb/Br)	CU NIPDAU	Level-3-260C-168 HR	-40 to 105	F28PLC84PNT TMS320	
TMS320F28PLC84PNTR	NRND	LQFP	PN	80	1000	Green (RoHS & no Sb/Br)	CU NIPDAU	Level-3-260C-168 HR	-40 to 105	F28PLC84PNT TMS320	

(1) The marketing status values are defined as follows:

**ACTIVE:** Product device recommended for new designs.

**LIFEBUY:** TI has announced that the device will be discontinued, and a lifetime-buy period is in effect.

**NRND:** Not recommended for new designs. Device is in production to support existing customers, but TI does not recommend using this part in a new design.

**PREVIEW:** Device has been announced but is not in production. Samples may or may not be available.

**OBSOLETE:** TI has discontinued the production of the device.

(2) **RoHS:** TI defines "RoHS" to mean semiconductor products that are compliant with the current EU RoHS requirements for all 10 RoHS substances, including the requirement that RoHS substance do not exceed 0.1% by weight in homogeneous materials. Where designed to be soldered at high temperatures, "RoHS" products are suitable for use in specified lead-free processes. TI may reference these types of products as "Pb-Free".

**RoHS Exempt:** TI defines "RoHS Exempt" to mean products that contain lead but are compliant with EU RoHS pursuant to a specific EU RoHS exemption.

**Green:** TI defines "Green" to mean the content of Chlorine (Cl) and Bromine (Br) based flame retardants meet JS709B low halogen requirements of <=1000ppm threshold. Antimony trioxide based flame retardants must also meet the <=1000ppm threshold requirement.

(3) MSL, Peak Temp. - The Moisture Sensitivity Level rating according to the JEDEC industry standard classifications, and peak solder temperature.

(4) There may be additional marking, which relates to the logo, the lot trace code information, or the environmental category on the device.

(5) Multiple Device Markings will be inside parentheses. Only one Device Marking contained in parentheses and separated by a "-" will appear on a device. If a line is indented then it is a continuation of the previous line and the two combined represent the entire Device Marking for that device.

(6) Lead/Ball Finish - Orderable Devices may have multiple material finish options. Finish options are separated by a vertical ruled line. Lead/Ball Finish values may wrap to two lines if the finish value exceeds the maximum column width.

**Important Information and Disclaimer:** The information provided on this page represents TI's knowledge and belief as of the date that it is provided. TI bases its knowledge and belief on information provided by third parties, and makes no representation or warranty as to the accuracy of such information. Efforts are underway to better integrate information from third parties. TI has taken and

continues to take reasonable steps to provide representative and accurate information but may not have conducted destructive testing or chemical analysis on incoming materials and chemicals. TI and TI suppliers consider certain information to be proprietary, and thus CAS numbers and other limited information may not be available for release.

In no event shall TI's liability arising out of such information exceed the total purchase price of the TI part(s) at issue in this document sold by TI to Customer on an annual basis.

PN (S-PQFP-G80)

PLASTIC QUAD FLATPACK

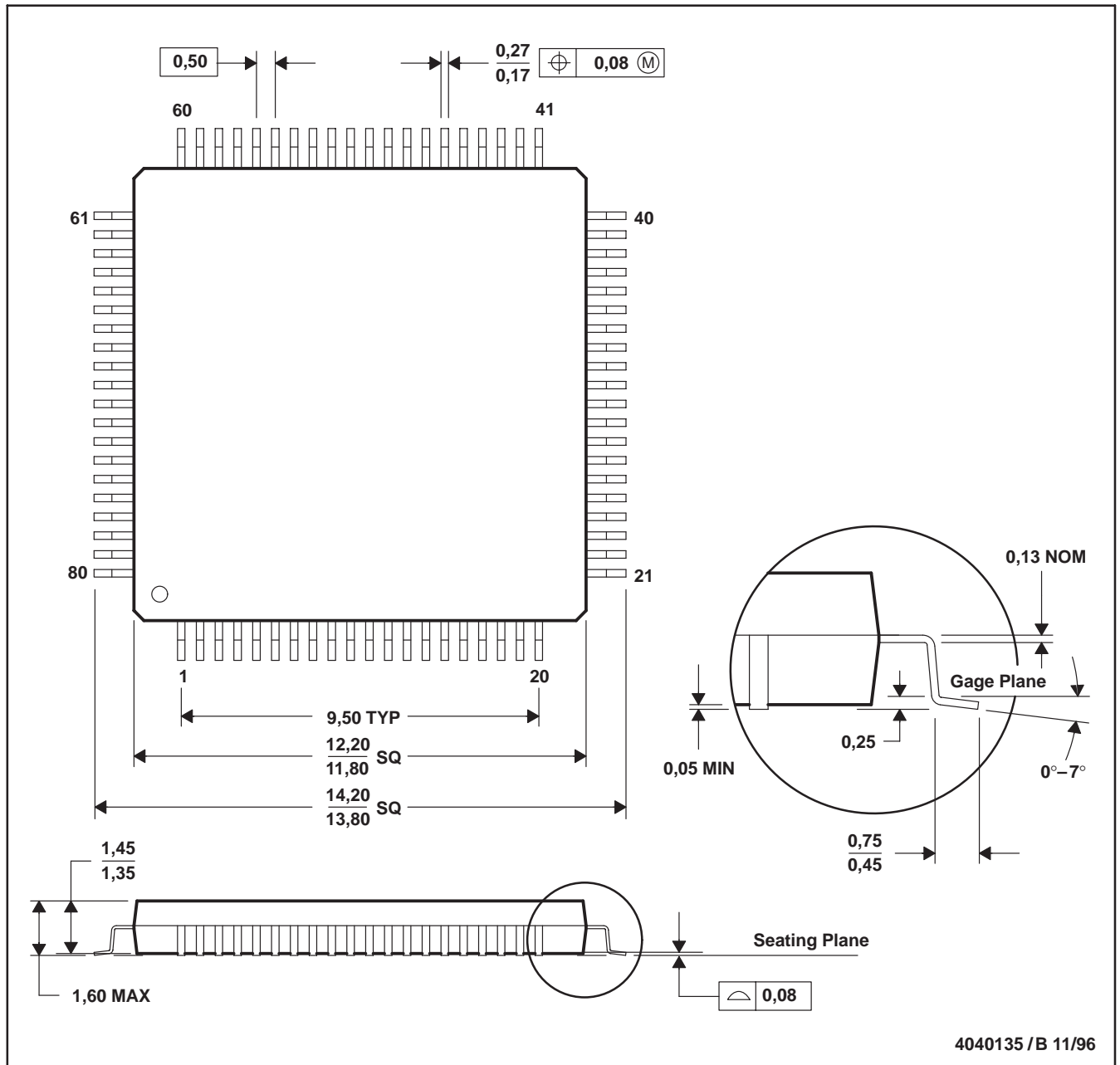

- NOTES: A. All linear dimensions are in millimeters.  
 B. This drawing is subject to change without notice.  
 C. Falls within JEDEC MS-026

## IMPORTANT NOTICE

Texas Instruments Incorporated (TI) reserves the right to make corrections, enhancements, improvements and other changes to its semiconductor products and services per JESD46, latest issue, and to discontinue any product or service per JESD48, latest issue. Buyers should obtain the latest relevant information before placing orders and should verify that such information is current and complete.

TI's published terms of sale for semiconductor products (<http://www.ti.com/sc/docs/stdterms.htm>) apply to the sale of packaged integrated circuit products that TI has qualified and released to market. Additional terms may apply to the use or sale of other types of TI products and services.

Reproduction of significant portions of TI information in TI data sheets is permissible only if reproduction is without alteration and is accompanied by all associated warranties, conditions, limitations, and notices. TI is not responsible or liable for such reproduced documentation. Information of third parties may be subject to additional restrictions. Resale of TI products or services with statements different from or beyond the parameters stated by TI for that product or service voids all express and any implied warranties for the associated TI product or service and is an unfair and deceptive business practice. TI is not responsible or liable for any such statements.

Buyers and others who are developing systems that incorporate TI products (collectively, "Designers") understand and agree that Designers remain responsible for using their independent analysis, evaluation and judgment in designing their applications and that Designers have full and exclusive responsibility to assure the safety of Designers' applications and compliance of their applications (and of all TI products used in or for Designers' applications) with all applicable regulations, laws and other applicable requirements. Designer represents that, with respect to their applications, Designer has all the necessary expertise to create and implement safeguards that (1) anticipate dangerous consequences of failures, (2) monitor failures and their consequences, and (3) lessen the likelihood of failures that might cause harm and take appropriate actions. Designer agrees that prior to using or distributing any applications that include TI products, Designer will thoroughly test such applications and the functionality of such TI products as used in such applications.

TI's provision of technical, application or other design advice, quality characterization, reliability data or other services or information, including, but not limited to, reference designs and materials relating to evaluation modules, (collectively, "TI Resources") are intended to assist designers who are developing applications that incorporate TI products; by downloading, accessing or using TI Resources in any way, Designer (individually or, if Designer is acting on behalf of a company, Designer's company) agrees to use any particular TI Resource solely for this purpose and subject to the terms of this Notice.

TI's provision of TI Resources does not expand or otherwise alter TI's applicable published warranties or warranty disclaimers for TI products, and no additional obligations or liabilities arise from TI providing such TI Resources. TI reserves the right to make corrections, enhancements, improvements and other changes to its TI Resources. TI has not conducted any testing other than that specifically described in the published documentation for a particular TI Resource.

Designer is authorized to use, copy and modify any individual TI Resource only in connection with the development of applications that include the TI product(s) identified in such TI Resource. NO OTHER LICENSE, EXPRESS OR IMPLIED, BY ESTOPPEL OR OTHERWISE TO ANY OTHER TI INTELLECTUAL PROPERTY RIGHT, AND NO LICENSE TO ANY TECHNOLOGY OR INTELLECTUAL PROPERTY RIGHT OF TI OR ANY THIRD PARTY IS GRANTED HEREIN, including but not limited to any patent right, copyright, mask work right, or other intellectual property right relating to any combination, machine, or process in which TI products or services are used. Information regarding or referencing third-party products or services does not constitute a license to use such products or services, or a warranty or endorsement thereof. Use of TI Resources may require a license from a third party under the patents or other intellectual property of the third party, or a license from TI under the patents or other intellectual property of TI.

TI RESOURCES ARE PROVIDED "AS IS" AND WITH ALL FAULTS. TI DISCLAIMS ALL OTHER WARRANTIES OR REPRESENTATIONS, EXPRESS OR IMPLIED, REGARDING RESOURCES OR USE THEREOF, INCLUDING BUT NOT LIMITED TO ACCURACY OR COMPLETENESS, TITLE, ANY EPIDEMIC FAILURE WARRANTY AND ANY IMPLIED WARRANTIES OF MERCHANTABILITY, FITNESS FOR A PARTICULAR PURPOSE, AND NON-INFRINGEMENT OF ANY THIRD PARTY INTELLECTUAL PROPERTY RIGHTS. TI SHALL NOT BE LIABLE FOR AND SHALL NOT DEFEND OR INDEMNIFY DESIGNER AGAINST ANY CLAIM, INCLUDING BUT NOT LIMITED TO ANY INFRINGEMENT CLAIM THAT RELATES TO OR IS BASED ON ANY COMBINATION OF PRODUCTS EVEN IF DESCRIBED IN TI RESOURCES OR OTHERWISE. IN NO EVENT SHALL TI BE LIABLE FOR ANY ACTUAL, DIRECT, SPECIAL, COLLATERAL, INDIRECT, PUNITIVE, INCIDENTAL, CONSEQUENTIAL OR EXEMPLARY DAMAGES IN CONNECTION WITH OR ARISING OUT OF TI RESOURCES OR USE THEREOF, AND REGARDLESS OF WHETHER TI HAS BEEN ADVISED OF THE POSSIBILITY OF SUCH DAMAGES.

Unless TI has explicitly designated an individual product as meeting the requirements of a particular industry standard (e.g., ISO/TS 16949 and ISO 26262), TI is not responsible for any failure to meet such industry standard requirements.

Where TI specifically promotes products as facilitating functional safety or as compliant with industry functional safety standards, such products are intended to help enable customers to design and create their own applications that meet applicable functional safety standards and requirements. Using products in an application does not by itself establish any safety features in the application. Designers must ensure compliance with safety-related requirements and standards applicable to their applications. Designer may not use any TI products in life-critical medical equipment unless authorized officers of the parties have executed a special contract specifically governing such use. Life-critical medical equipment is medical equipment where failure of such equipment would cause serious bodily injury or death (e.g., life support, pacemakers, defibrillators, heart pumps, neurostimulators, and implantables). Such equipment includes, without limitation, all medical devices identified by the U.S. Food and Drug Administration as Class III devices and equivalent classifications outside the U.S.

TI may expressly designate certain products as completing a particular qualification (e.g., Q100, Military Grade, or Enhanced Product). Designers agree that it has the necessary expertise to select the product with the appropriate qualification designation for their applications and that proper product selection is at Designers' own risk. Designers are solely responsible for compliance with all legal and regulatory requirements in connection with such selection.

Designer will fully indemnify TI and its representatives against any damages, costs, losses, and/or liabilities arising out of Designer's non-compliance with the terms and provisions of this Notice.