



## 2.8-W STEREO FULLY DIFFERENTIAL AUDIO POWER AMPLIFIER

### FEATURES

- Ideal for Notebook PCs
- Fully Differential Architecture and High PSRR (-80 dB) Provide Excellent RF Rectification Immunity
- 2.8 W Into 3 Ω From a 5-V Supply at THD = 10% (Typical)
- Very Low Crosstalk:
  - -100 dB Typical at 5 V, 3 Ω
- 2.5-V to 5.5-V Operating Range
- Low Supply Current:
  - 8 mA Typical at 5 V
  - Shutdown Current: 80-nA Typical
- Fast Startup (27 ms) With Minimal Pop
- Internal Feedback Resistors Reduce Component Count
- Thermally Enhanced QFN Packaging

### APPLICATIONS

- Notebook PCs
- LCD TVs

### DESCRIPTION

The TPA6020A2 is a 2.8-W stereo bridge-tied load (BTL) amplifier designed to drive stereo speakers with at least 3-Ω impedance. The device operates from 2.5 V to 5.5 V, drawing only 8 mA of quiescent supply current. The feedback resistors are internal, allowing the gain to be set with only two input resistors per channel. The amplifier's fully differential architecture performs with -80 dB of power supply rejection from 20 Hz to 2 kHz, improved RF rectification immunity, small PCB area, and a fast startup time with minimal pop, making the TPA6020A2 ideal for notebook PC applications.

### APPLICATION CIRCUIT

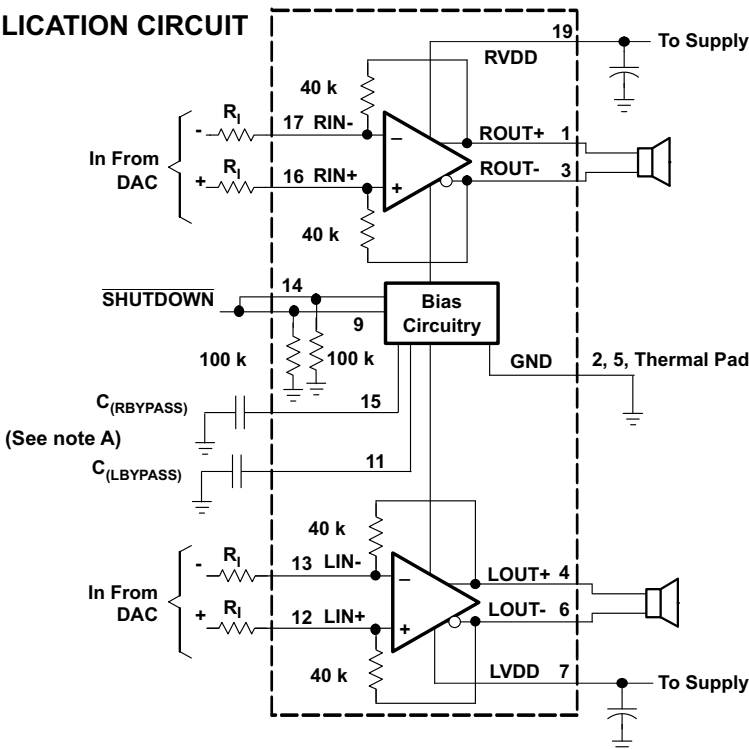

A.  $C_{(LBPASS)}$  and  $C_{(RBPASS)}$  are optional.

20-PIN QFN (RGW) PACKAGE (TOP VIEW)

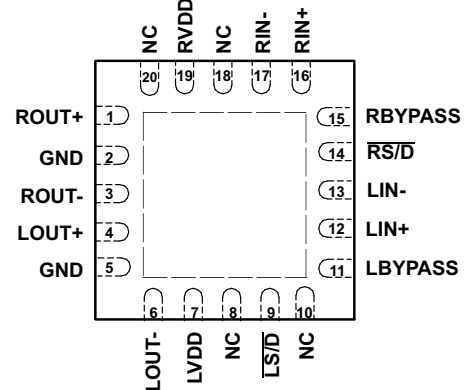

Please be aware that an important notice concerning availability, standard warranty, and use in critical applications of Texas Instruments semiconductor products and disclaimers thereto appears at the end of this data sheet.



These devices have limited built-in ESD protection. The leads should be shorted together or the device placed in conductive foam during storage or handling to prevent electrostatic damage to the MOS gates.

**ORDERING INFORMATION**

T <sub>A</sub>	PACKAGED DEVICES <sup>(1)(2)</sup>	EVALUATION MODULES
	QFN (RGW)	
-40°C to 85°C	TPA6020A2RGW	TPA6020A2EVM

- (1) The RGW is available taped and reeled. To order taped and reeled parts, add the suffix R to the part number (TPA6020A2RGWR).
- (2) For the most current package and ordering information, see the Package Option Addendum at the end of this document, or see the TI website at [www.ti.com](http://www.ti.com).

**ABSOLUTE MAXIMUM RATINGS**

over operating free-air temperature range unless otherwise noted<sup>(1)</sup>

		UNIT
V <sub>DD</sub>	Supply voltage	-0.3 V to 6 V
V <sub>I</sub>	Input voltage	-0.3 V to V <sub>DD</sub> + 0.3 V
	Continuous total power dissipation	See Dissipation Rating Table
T <sub>A</sub>	Operating free-air temperature	-40°C to 85°C
T <sub>J</sub>	Junction temperature	-40°C to 150°C
T <sub>stg</sub>	Storage temperature	-65°C to 85°C
	Lead temperature 1,6 mm (1/16 Inch) from case for 10 seconds	260°C
Electrostatic discharge	Human body model <sup>(2)</sup> (all pins)	±2 kV
	Charged-device model <sup>(3)</sup> (all pins)	±500 V

- (1) Stresses beyond those listed under "absolute maximum ratings" may cause permanent damage to the device. These are stress ratings only, and functional operation of the device at these or any other conditions beyond those indicated under "recommended operating conditions" is not implied. Exposure to absolute-maximum-rated conditions for extended periods may affect device reliability.
- (2) In accordance with JEDEC Standard 22, Test Method A114-B.
- (3) In accordance with JEDEC Standard 22, Test Method C101-A

**PACKAGE DISSIPATION RATINGS**

PACKAGE	T <sub>A</sub> 25°C POWER RATING	DERATING FACTOR <sup>(1)</sup>	T <sub>A</sub> = 70°C POWER RATING	T <sub>A</sub> = 85°C POWER RATING
RGW	2.99 W	23.98 mW/°C	1.92 W	1.56 W

- (1) Derating factor based on high-k board layout.

**RECOMMENDED OPERATION CONDITIONS**

		MIN	TYP	MAX	UNIT
V <sub>DD</sub>	Supply voltage	2.5		5.5	V
V <sub>IH</sub>	High-level input voltage	SHUTDOWN	1.55		V
V <sub>IL</sub>	Low-level input voltage	SHUTDOWN		0.5	V
T <sub>A</sub>	Operating free-air temperature	-40		85	°C

**ELECTRICAL CHARACTERISTICS**
 $T_A = 25^\circ\text{C}$ 

PARAMETER		TEST CONDITIONS	MIN	TYP	MAX	UNIT
$V_{OS}$	Output offset voltage (measured differentially)	$V_I = 0\text{ V}$ differential, Gain = 1 V/V, $V_{DD} = 5.5\text{ V}$	-9	0.3	9	mV
PSRR	Power supply rejection ratio	$V_{DD} = 2.5\text{ V}$ to 5.5 V		-85		dB
$V_{IC}$	Common-mode input range	$V_{DD} = 2.5\text{ V}$ to 5.5 V	0.5		$V_{DD}-0.8$	V
CMRR	Common-mode rejection ratio	$V_{DD} = 5.5\text{ V}$ , $V_{IC} = 0.5\text{ V}$ to 4.7 V		-63		dB
		$V_{DD} = 2.5\text{ V}$ , $V_{IC} = 0.5\text{ V}$ to 1.7 V		-63		
Low-output swing		$R_L = 3\ \Omega$ , $V_{IN+} = V_{DD}$ , $V_{IN-} = 0\text{ V}$ , Gain = 1 V/V, $V_{IN-} = 0\text{ V}$ or $V_{IN-} = V_{DD}$	$V_{DD} = 5.5\text{ V}$	0.55		V
			$V_{DD} = 3.6\text{ V}$	0.42		
			$V_{DD} = 2.5\text{ V}$	0.34	0.4	
High-output swing		$R_L = 3\ \Omega$ , $V_{IN+} = V_{DD}$ , $V_{IN-} = V_{DD}$ , Gain = 1 V/V, $V_{IN-} = 0\text{ V}$ or $V_{IN+} = 0\text{ V}$	$V_{DD} = 5.5\text{ V}$	4.9		V
			$V_{DD} = 3.6\text{ V}$	3.1		
			$V_{DD} = 2.5\text{ V}$	1.9	2.1	
$ I_{IH} $	High-level input current, shutdown	$V_{DD} = 5.5\text{ V}$ , $V_I = 5.8\text{ V}$		58	100	$\mu\text{A}$
$ I_{IL} $	Low-level input current, shutdown	$V_{DD} = 5.5\text{ V}$ , $V_I = -0.3\text{ V}$		3	100	$\mu\text{A}$
$I_Q$	Quiescent current	$V_{DD} = 2.5\text{ V}$ to 5.5 V, no load		8	9.8	mA
$I_{(SD)}$	Supply current	$V(\text{SHUTDOWN}) \leq 0.5\text{ V}$ , $V_{DD} = 2.5\text{ V}$ to 5.5 V, $R_L = 3\ \Omega$		0.08	1	$\mu\text{A}$
Gain		$R_L = 3\ \Omega$	$\frac{38\text{ k}\Omega}{R_1}$	$\frac{40\text{ k}\Omega}{R_1}$	$\frac{42\text{ k}\Omega}{R_1}$	V/V
	Resistance from shutdown to GND			100		k $\Omega$

**OPERATING CHARACTERISTICS** $T_A = 25^\circ\text{C}$ , Gain = 2 V/V

PARAMETER		TEST CONDITIONS		MIN	TYP	MAX	UNIT
$P_O$	Output power	THD + N= 1%, f = 1 kHz, $R_L = 3 \Omega$	$V_{DD} = 5 \text{ V}$		2.15		W
			$V_{DD} = 3.6 \text{ V}$		1.08		
			$V_{DD} = 2.5 \text{ V}$		0.43		
		THD + N= 1%, f = 1 kHz, $R_L = 4 \Omega$	$V_{DD} = 5 \text{ V}$		1.94		
			$V_{DD} = 3.6 \text{ V}$		1.00		
			$V_{DD} = 2.5 \text{ V}$		0.41		
		THD + N= 1%, f = 1 kHz, $R_L = 8 \Omega$	$V_{DD} = 5 \text{ V}$		1.27		
			$V_{DD} = 3.6 \text{ V}$		0.65		
			$V_{DD} = 2.5 \text{ V}$		0.29		
THD+N	Total harmonic distortion plus noise	f = 1 kHz, $R_L = 3 \Omega$	$P_O = 2 \text{ W}$	$V_{DD} = 5 \text{ V}$		0.09%	
			$P_O = 1 \text{ W}$	$V_{DD} = 3.6 \text{ V}$		0.20%	
			$P_O = 300 \text{ mW}$	$V_{DD} = 2.5 \text{ V}$		0.08%	
		f = 1 kHz, $R_L = 4 \Omega$	$P_O = 1.8 \text{ W}$	$V_{DD} = 5 \text{ V}$		0.08%	
			$P_O = 0.7 \text{ W}$	$V_{DD} = 3.6 \text{ V}$		0.07%	
			$P_O = 300 \text{ mW}$	$V_{DD} = 2.5 \text{ V}$		0.12%	
		f = 1 kHz, $R_L = 8 \Omega$	$P_O = 1 \text{ W}$	$V_{DD} = 5 \text{ V}$		0.05%	
			$P_O = 0.5 \text{ W}$	$V_{DD} = 3.6 \text{ V}$		0.06%	
			$P_O = 200 \text{ mW}$	$V_{DD} = 2.5 \text{ V}$		0.06%	
$k_{SVR}$	Supply ripple rejection ratio	$V_{DD} = 3.6 \text{ V}$ , Inputs ac-grounded with $C_1 = 2 \mu\text{F}$ , $V_{(RIPPLE)} = 200 \text{ mV}_{pp}$	f = 217 Hz		-80	dB	
			f = 20 Hz to 20 kHz		-70		
	Crosstalk	$V_{DD} = 5 \text{ V}$ , $R_L = 3 \Omega$ , f = 20 Hz to 20 kHz, $P_o = 1 \text{ W}$			-100	dB	
SNR	Signal-to-noise ratio	$V_{DD} = 5 \text{ V}$ , $P_O = 2 \text{ W}$ , $R_L = 3 \Omega$ , Gain = 1 V/V			104	dB	
$V_n$	Output voltage noise	$V_{DD} = 3.6 \text{ V}$ , f = 20 Hz to 20 kHz, Gain = 1 V/V Inputs ac grounded with $C_1 = 0.22 \mu\text{F}$	No weighting		15	$\mu\text{V}_{RMS}$	
			A weighting		12		
CMRR	Common-mode rejection ratio	$V_{DD} = 3.6 \text{ V}$ , $V_{IC} = 200 \text{ mV}_{pp}$	f = 217 Hz		-65	dB	
$Z_I$	Input impedance			38	40	42	k $\Omega$
	Start-up time from shutdown	$V_{DD} = 3.6 \text{ V}$ , No $C_{BYPASS}$			4	$\mu\text{s}$	
		$V_{DD} = 3.6 \text{ V}$ , $C_{BYPASS} = 0.1 \mu\text{F}$			27	ms	

**Terminal Functions**

TERMINAL		I/O	DESCRIPTION
NAME	NO.		
ROUT+	1	O	Right channel positive BTL output
GND	2,5	I	High current ground
ROUT-	3	O	Right channel negative BTL output
LOUT+	4	O	Left channel positive BTL output
LOUT-	6	O	Left channel negative BTL output
LVDD	7	I	Left channel power supply. Must be tied to RVDD for stereo operation.
NC	8, 10, 18, 20	–	No internal connection.
$\overline{\text{LS/D}}$	9	I	Left channel shutdown terminal (active low logic)
LBYPASS	11	–	Left channel mid-supply voltage. Adding a bypass capacitor improves PSRR
LIN+	12	I	Left channel positive differential input
LIN-	13	I	Left channel negative differential input
$\overline{\text{RS/D}}$	14	–	Right channel shutdown terminal (active low logic)
RBYPASS	15	–	Right channel mid-supply voltage. Adding a bypass capacitor improves PSRR
RIN+	16	I	Right channel positive differential input
RIN-	17	I	Right channel negative differential input
RVDD	19	I	Power supply
Thermal Pad	–	–	Connect to ground. Thermal pad must be soldered down in all applications to properly secure device on the PCB.

TYPICAL CHARACTERISTICS

Table of Graphs

			FIGURE
P <sub>O</sub>	Output power	vs Supply voltage	1
		vs Load resistance	2
P <sub>D</sub>	Power dissipation	vs Output power	3, 4
		vs Frequency	5, 6, 7
THD+N	Total harmonic distortion + noise	vs Frequency	8, 9, 10, 11, 12, 13
		Crosstalk	14
K <sub>SVR</sub>	Supply voltage rejection ratio	vs Frequency	15, 16, 17, 18
		GSM power supply rejection	19
CMRR	Common-mode rejection ratio	vs Frequency	20
		vs Common-mode input voltage	21
	Closed-loop gain/phase	vs Frequency	22
	Open-loop gain/phase	vs Frequency	23
	Start-up time	vs Bypass capacitor	24
			25

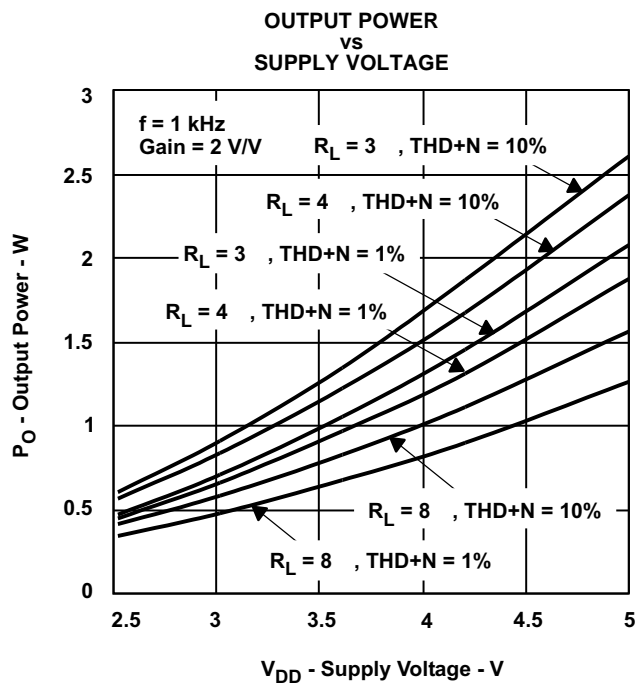

Figure 1.

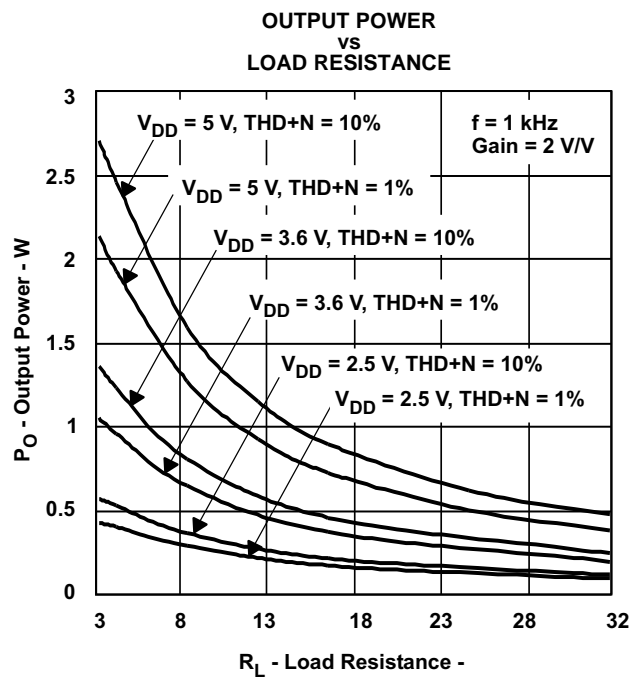

Figure 2.

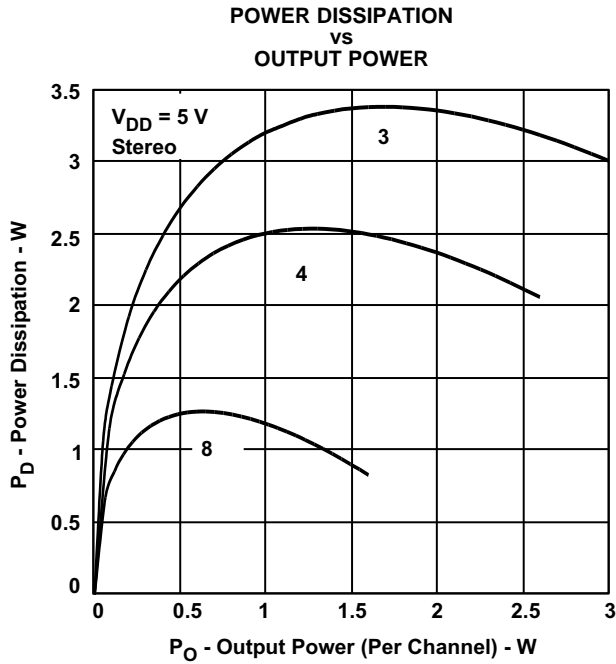

Figure 3.

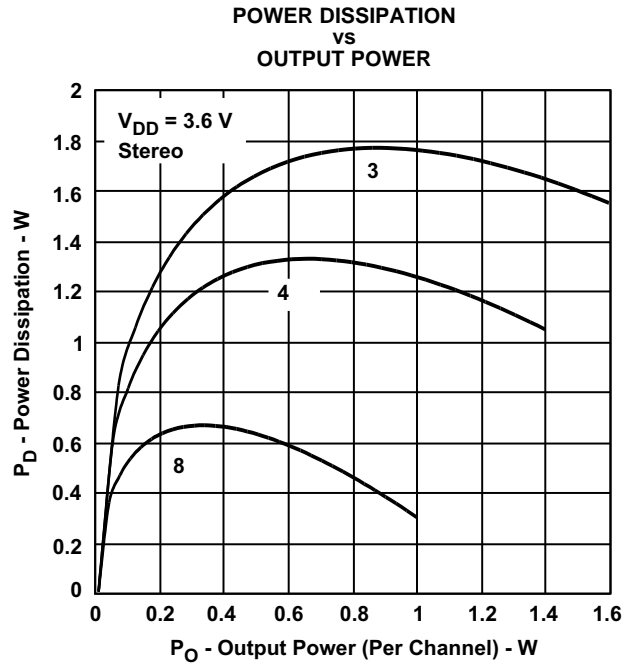

Figure 4.

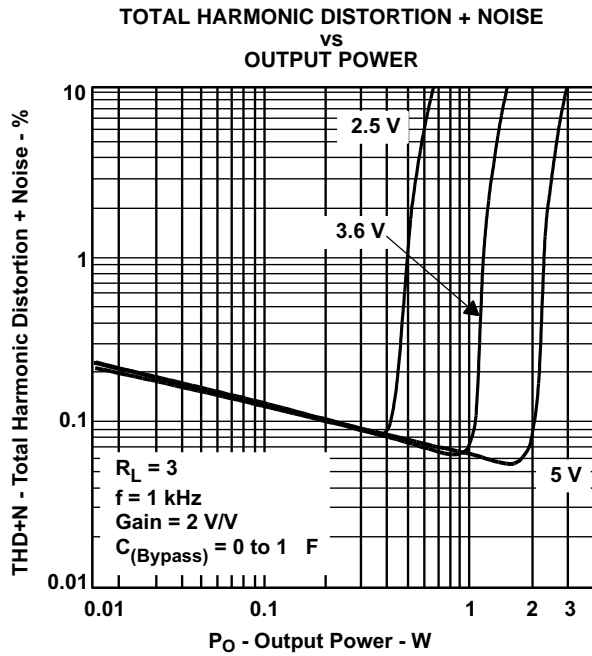

Figure 5.

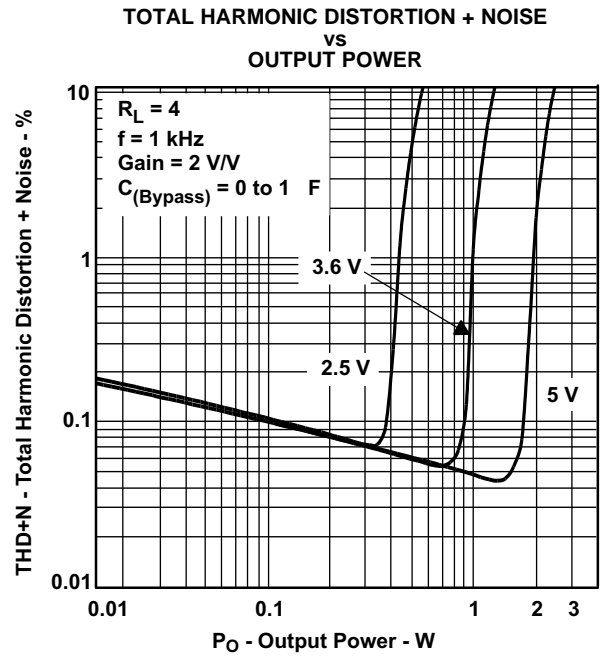

Figure 6.

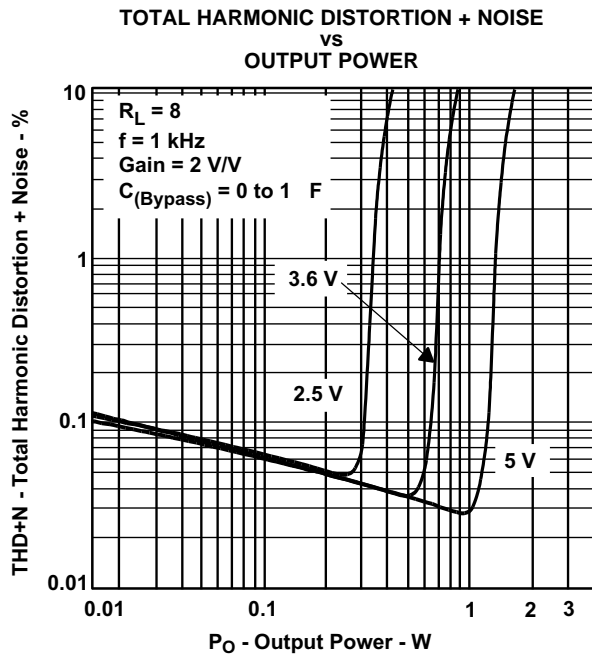

Figure 7.

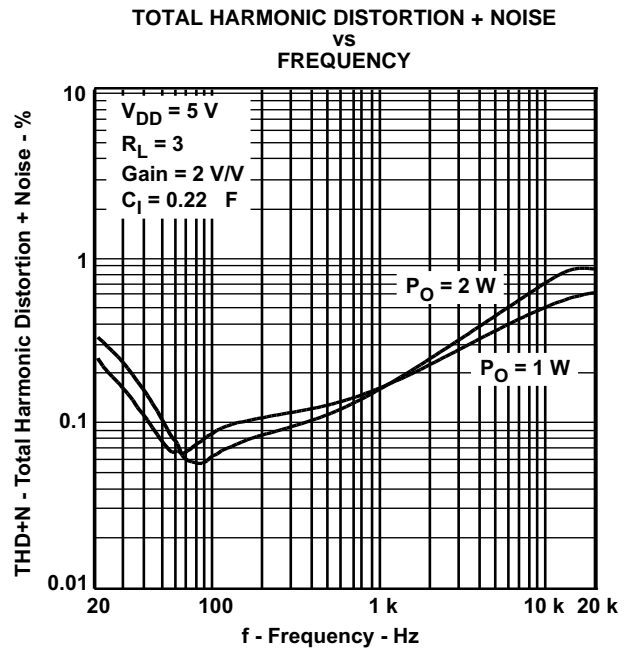

Figure 8.

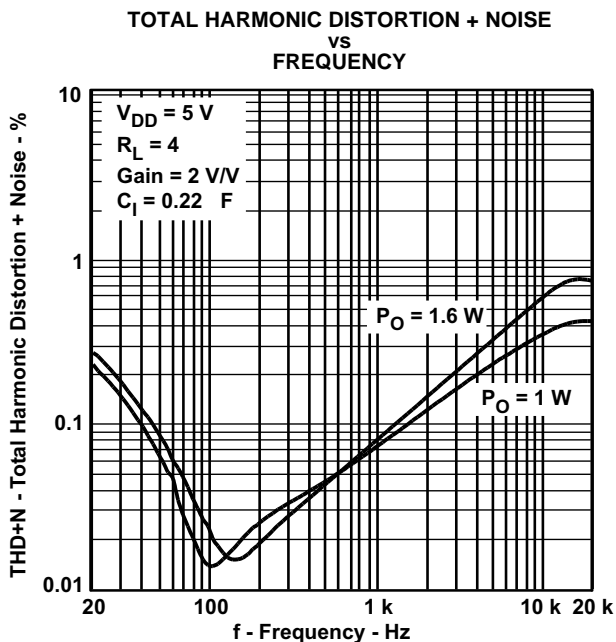

Figure 9.

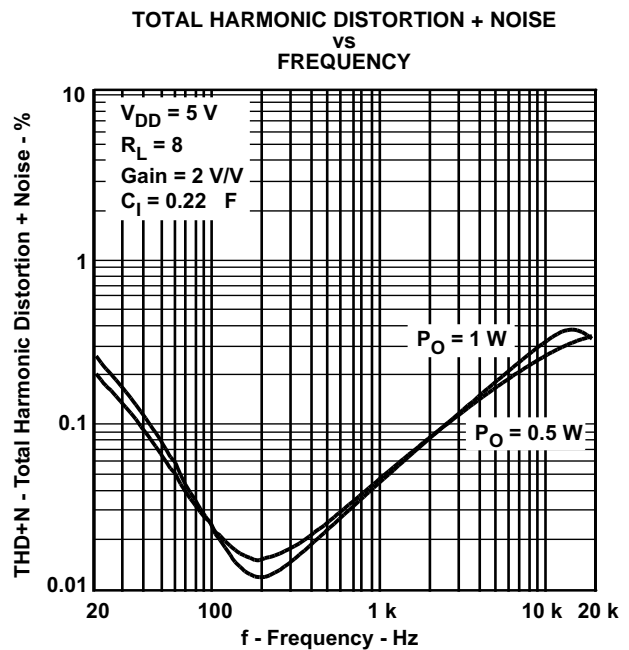

Figure 10.

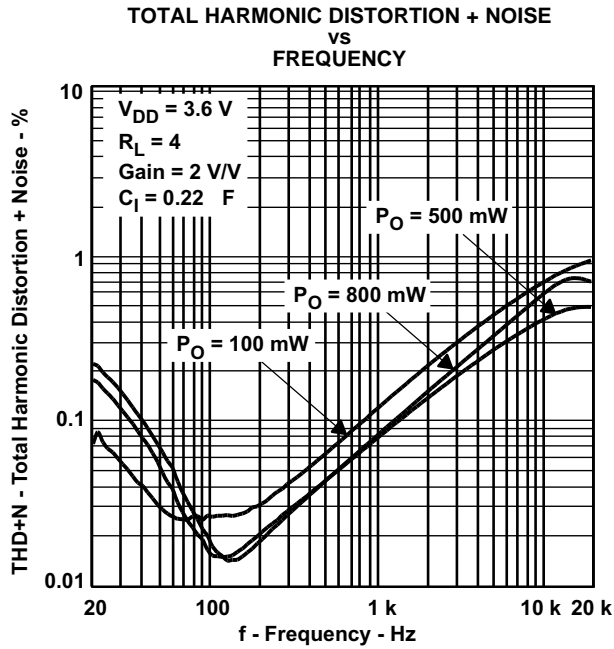

Figure 11.

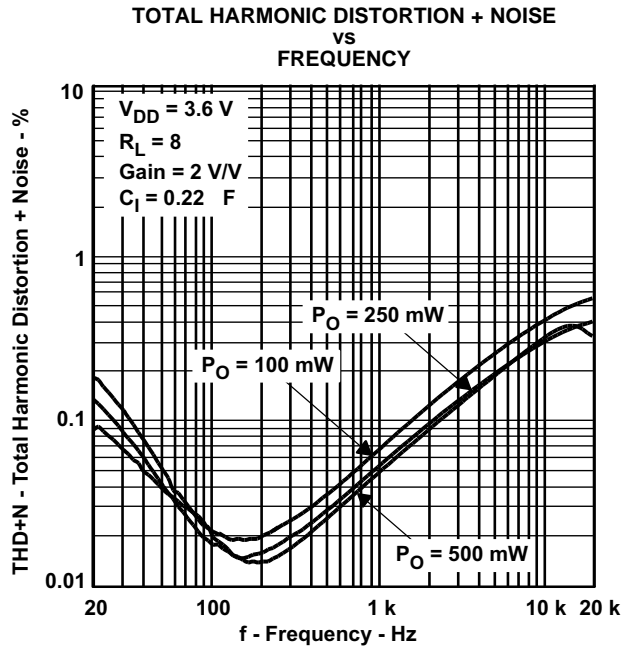

Figure 12.

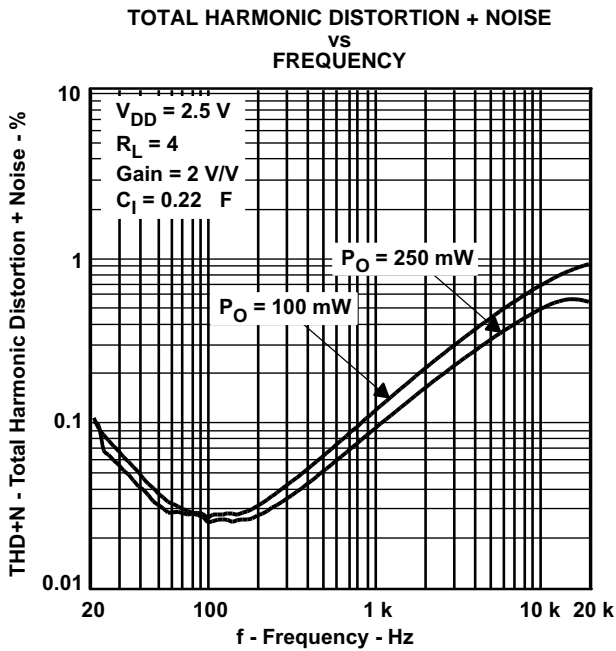

Figure 13.

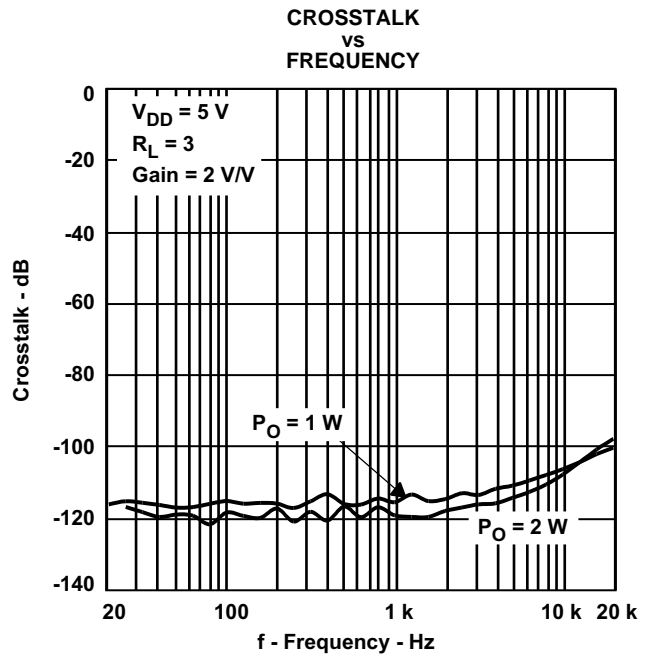

Figure 14.

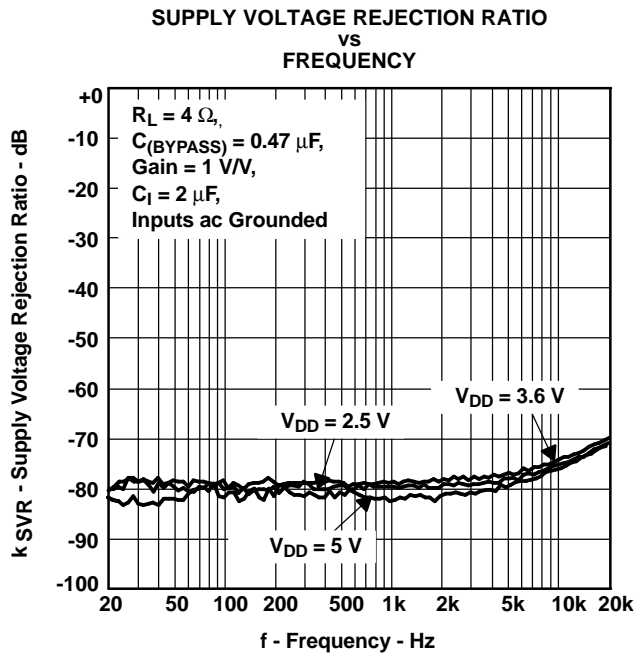

Figure 15.

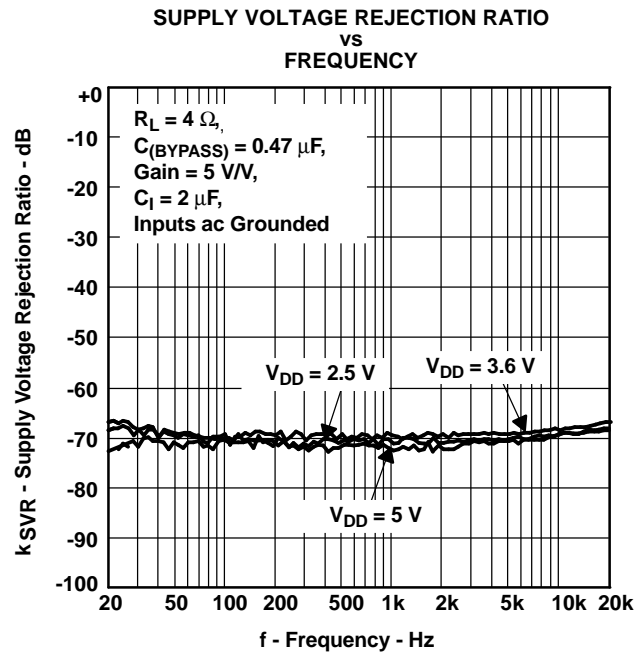

Figure 16.

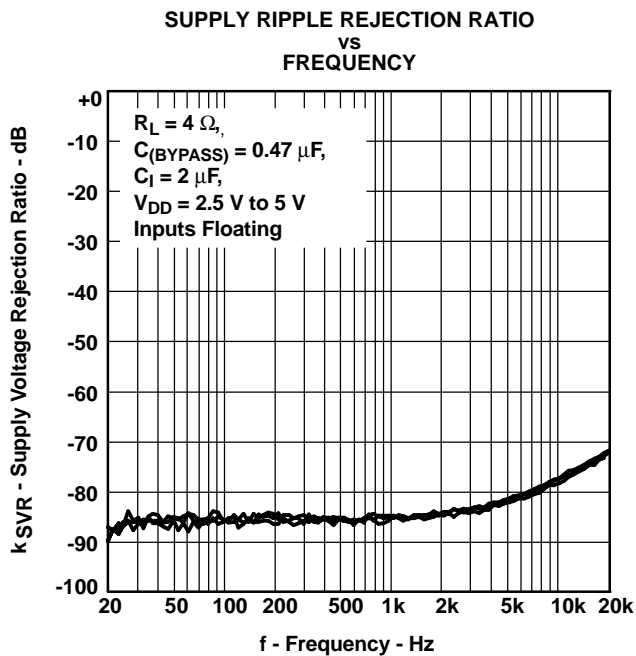

Figure 17.

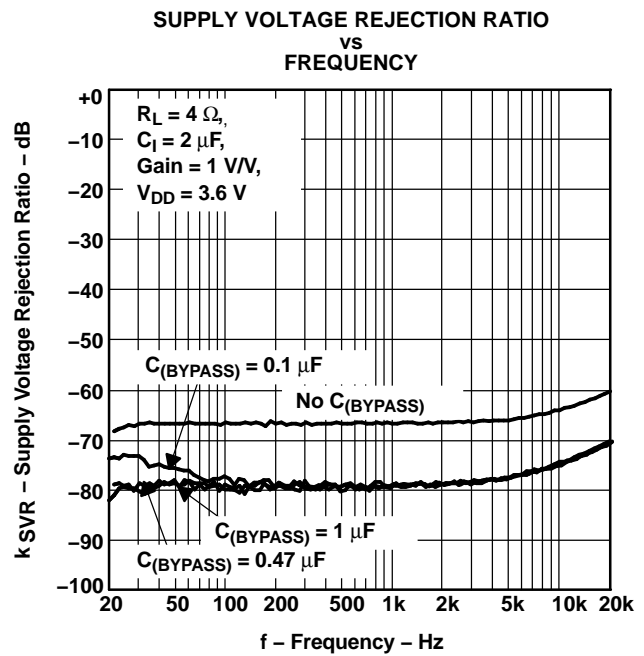

Figure 18.

GSM POWER SUPPLY REJECTION  
vs  
TIME

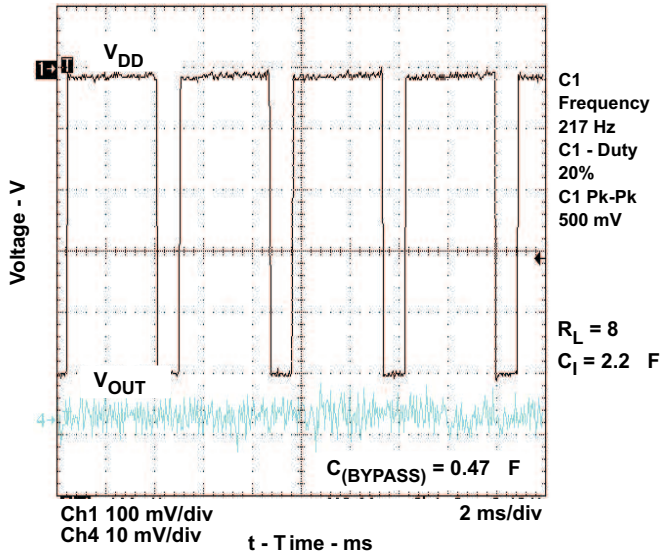

Figure 19.

GSM POWER SUPPLY REJECTION  
vs  
FREQUENCY

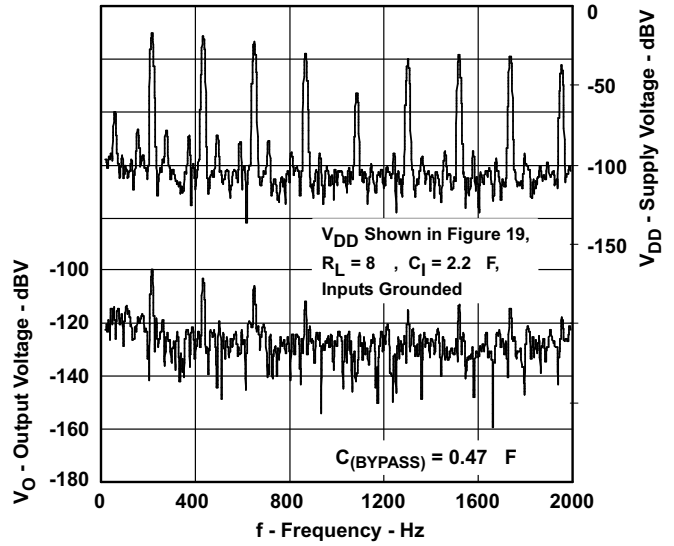

Figure 20.

COMMON MODE REJECTION RATIO  
vs  
FREQUENCY

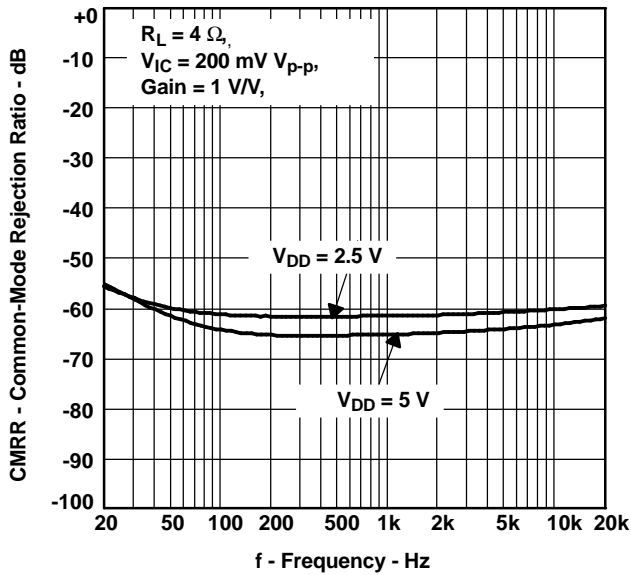

Figure 21.

COMMON-MODE REJECTION RATIO  
vs  
COMMON-MODE INPUT VOLTAGE

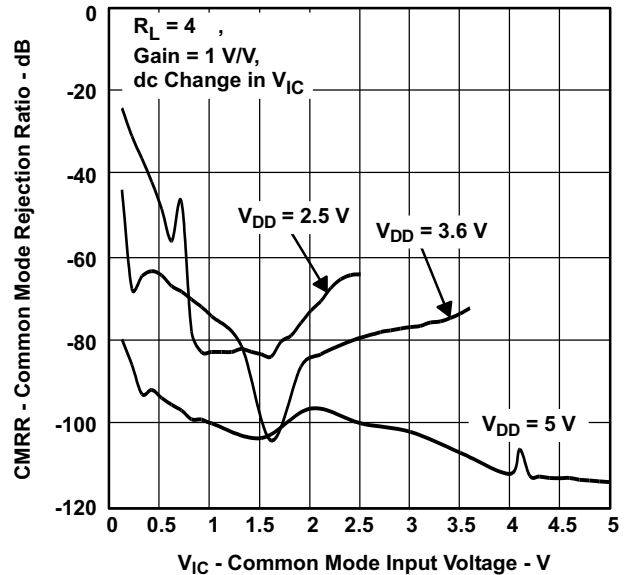

Figure 22.

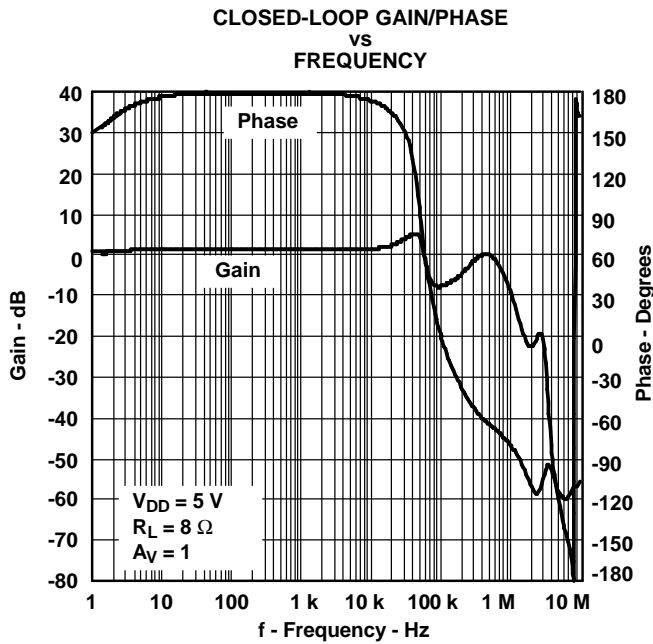

Figure 23.

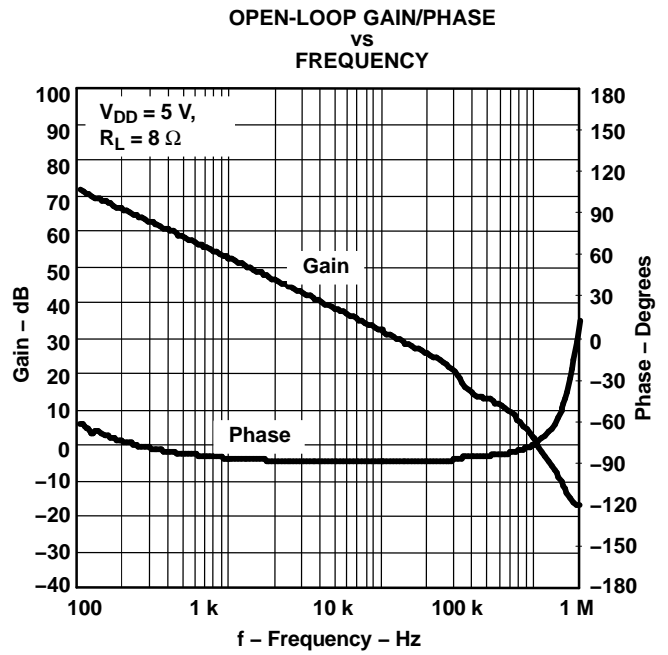

Figure 24.

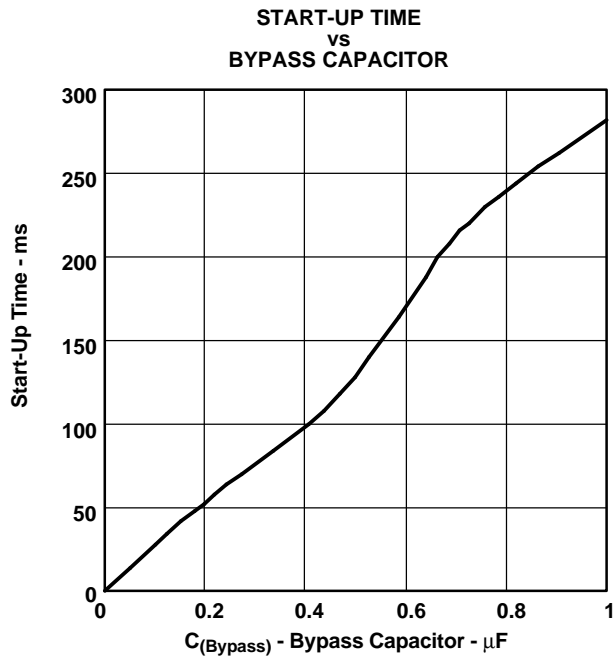

Figure 25.

## APPLICATION INFORMATION

### STEREO OPERATION

The TPA6020A2 is a stereo amplifier that can be operated in either a mono or stereo configuration. Each channel has independent shutdown control, giving the user greater flexibility.

#### Bypass Capacitor Configuration

If Bypass capacitors are used, it is necessary to use separate bypass capacitors for each bypass pin. (See the section entitled *Bypass Capacitor ( $C_{BYPASS}$ ) and Start-Up Time*)

#### VDD and Decoupling Capacitors

Each VDD pin must have a separate power supply decoupling capacitor (see section entitled *Decoupling Capacitor ( $C_S$ )*). A single, bulk decoupling capacitor is also recommended. Additionally, the left and right channel VDD pins must be tied together on the PCB.

### FULLY DIFFERENTIAL AMPLIFIER

The TPA6020A2 is a fully differential amplifier with differential inputs and outputs. The fully differential amplifier consists of a differential amplifier and a common-mode amplifier. The differential amplifier ensures that the amplifier outputs a differential voltage that is equal to the differential input times the gain. The common-mode feedback ensures that the common-mode voltage at the output is biased around  $V_{DD}/2$  regardless of the common-mode voltage at the input.

#### Advantages of Fully Differential Amplifiers

- **Input coupling capacitors not required:** A fully differential amplifier with good CMRR, like the TPA6020A2, allows the inputs to be biased at voltage other than mid-supply. For example, if a

DAC has a lower mid-supply voltage than that of the TPA6020A2, the common-mode feedback circuit compensates, and the outputs are still biased at the mid-supply point of the TPA6020A2. The inputs of the TPA6020A2 can be biased from 0.5 V to  $V_{DD} - 0.8$  V. If the inputs are biased outside of that range, input-coupling capacitors are required.

- **Mid-supply bypass capacitor,  $C_{(BYPASS)}$ , not required:** The fully differential amplifier does not require a bypass capacitor. Any shift in the mid-supply voltage affects both positive and negative channels equally, thus canceling at the differential output. Removing the bypass capacitor slightly worsens power supply rejection ratio ( $k_{SVR}$ ), but a slight decrease of  $k_{SVR}$  may be acceptable when an additional component can be eliminated (see [Figure 18](#)).
- **Better RF-immunity:** GSM handsets save power by turning on and shutting off the RF transmitter at a rate of 217 Hz. The transmitted signal is picked up on input and output traces. The fully differential amplifier cancels the signal much better than the typical audio amplifier.

### APPLICATION SCHEMATICS

[Figure 26](#) through [Figure 29](#) show application schematics for differential and single-ended inputs. Typical values are shown in [Table 1](#).

**Table 1. Typical Component Values**

COMPONENT	VALUE
$R_I$	40 k $\Omega$
$C_{(BYPASS)}^{(1)}$	0.22 $\mu$ F
$C_S$	1 $\mu$ F
$C_I$	0.22 $\mu$ F

(1)  $C_{(BYPASS)}$  is optional.

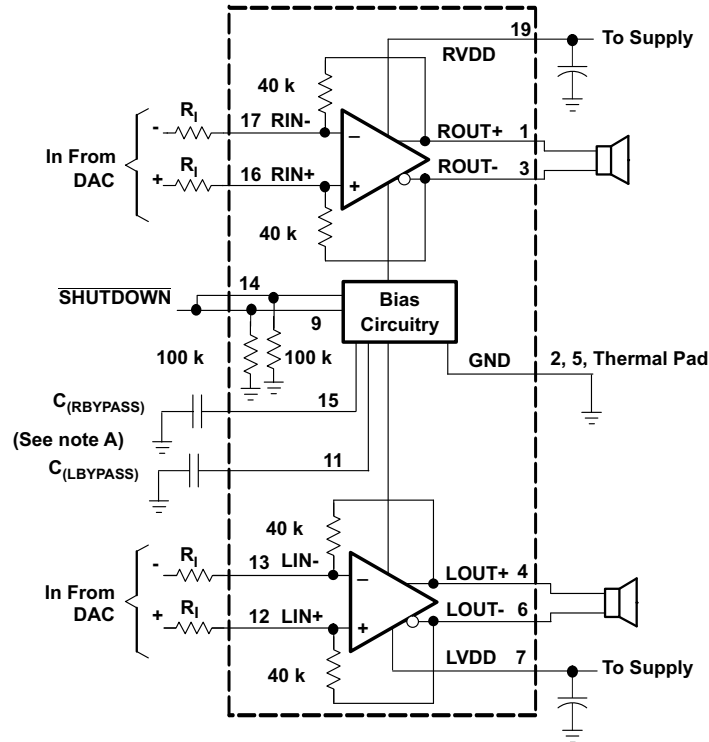

A.  $C_{(LBYPASS)}$  and  $C_{(RBYPASS)}$  are optional.

**Figure 26. Typical Differential Input Application Schematic**

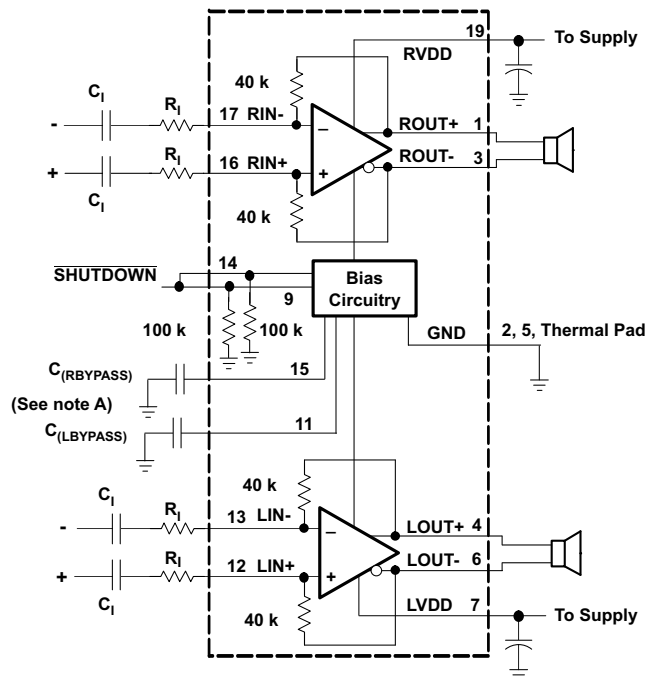

A.  $C_{(LBYPASS)}$  and  $C_{(RBYPASS)}$  are optional.

**Figure 27. Differential Input Application Schematic Optimized With Input Capacitors**

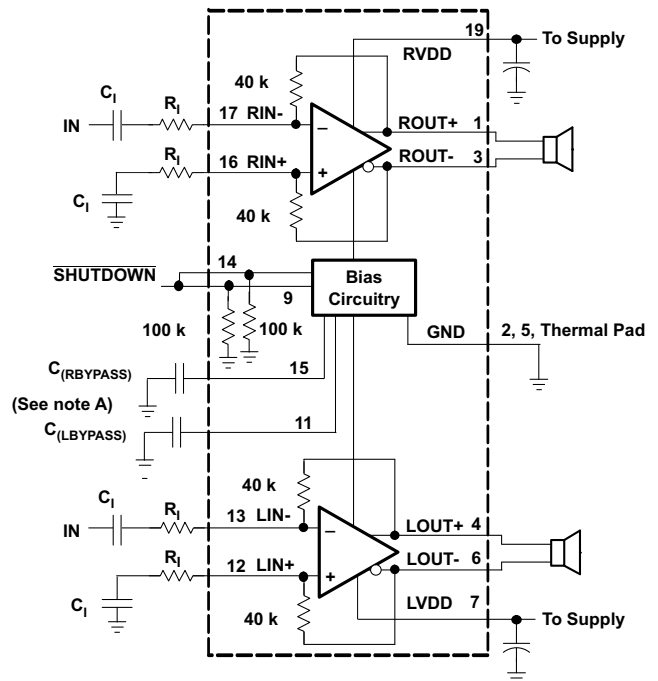

A.  $C_{(LBYPASS)}$  and  $C_{(RBYPASS)}$  are optional.

**Figure 28. Single-Ended Input Application Schematic**

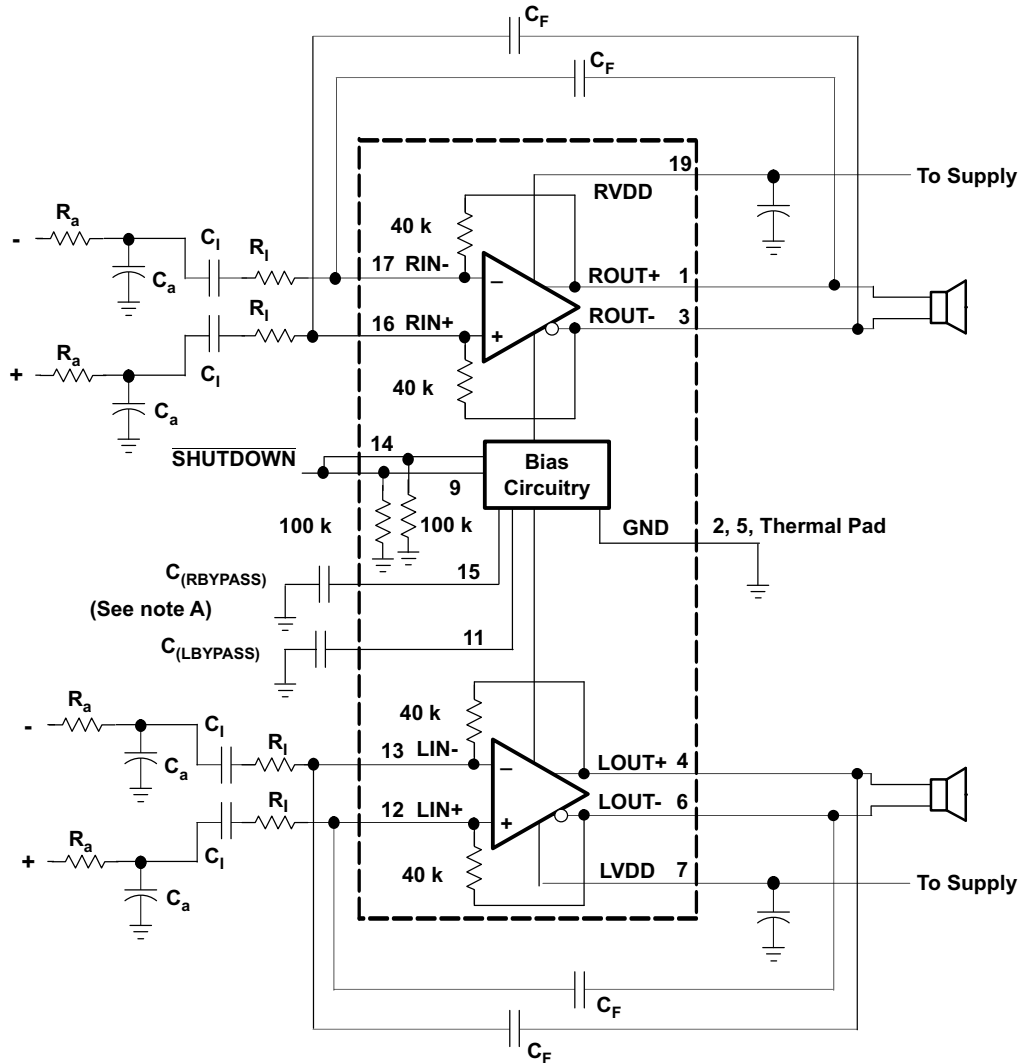

A.  $C_{(LBYPASS)}$  and  $C_{(RBYPASS)}$  are optional.

**Figure 29. Differential Input Application Schematic With Input Bandpass Filter**

## Selecting Components

### Resistors ( $R_i$ )

The input resistor ( $R_i$ ) can be selected to set the gain of the amplifier according to [Equation 1](#).

$$\text{Gain} = R_F/R_i \quad (1)$$

The internal feedback resistors ( $R_F$ ) are trimmed to 40 kΩ.

Matching input resistors are important to fully differential amplifier applications. Resistor matching has a significant impact on CMRR and PSRR. If the input resistor values are poorly matched, then the CMRR and PSRR performance is diminished. Therefore, 1%-tolerance resistors or better are recommended to optimize performance.

### Bypass Capacitor ( $C_{BYPASS}$ ) and Start-Up Time

The internal voltage divider at the BYPASS pin of this device sets a mid-supply voltage for internal references and sets the output common-mode voltage to  $V_{DD}/2$ . Adding a capacitor filters any noise into this pin, increasing  $k_{SVR}$ .  $C_{(BYPASS)}$  also determines the rise time of  $V_{O+}$  and  $V_{O-}$  when the device exits shutdown. The larger the capacitor, the slower the rise time.

### Input Capacitor ( $C_i$ )

The TPA6020A2 does not require input coupling capacitors when driven by a differential input source biased from 0.5 V to  $V_{DD} - 0.8$  V. Use 1% tolerance or better gain-setting resistors if not using input-coupling capacitors.

In the single-ended input application, an input capacitor,  $C_I$ , is required to allow the amplifier to bias the input signal to the proper dc level. In this case,  $C_I$  and  $R_I$  form a high-pass filter with the corner frequency defined in Equation 2.

$$f_c = \frac{1}{2\pi R_I C_I} \quad (2)$$

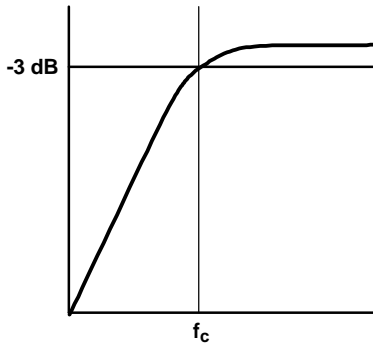

The value of  $C_I$  is an important consideration. It directly affects the bass (low frequency) performance of the circuit. Consider the example where  $R_I$  is 10 k $\Omega$  and the specification calls for a flat bass response down to 100 Hz. Equation 2 is reconfigured as Equation 3.

$$C_I = \frac{1}{2\pi R_I f_c} \quad (3)$$

In this example,  $C_I$  is 0.16  $\mu$ F, so the likely choice ranges from 0.22  $\mu$ F to 0.47  $\mu$ F. Ceramic capacitors are preferred because they are the best choice in preventing leakage current. When polarized capacitors are used, the positive side of the capacitor faces the amplifier input in most applications. The input dc level is held at  $V_{DD}/2$ , typically higher than the source dc level. It is important to confirm the capacitor polarity in the application.

#### Band-Pass Filter ( $R_a$ , $C_a$ , and $C_a$ )

It may be desirable to have signal filtering beyond the one-pole high-pass filter formed by the combination of  $C_I$  and  $R_I$ . A low-pass filter may be added by placing a capacitor ( $C_F$ ) between the inputs and outputs, forming a band-pass filter.

An example of when this technique might be used would be in an application where the desirable pass-band range is between 100 Hz and 10 kHz, with a gain of 4 V/V. The following equations illustrate how the proper values of  $C_F$  and  $C_I$  can be determined.

#### Step 1: Low-Pass Filter

$$f_{c(\text{LPF})} = \frac{1}{2\pi R_F C_F}$$

where  $R_F$  is the internal 40 k $\Omega$  resistor (4)

$$f_{c(\text{LPF})} = \frac{1}{2\pi 40 \text{ k}\Omega C_F} \quad (5)$$

Therefore,

$$C_F = \frac{1}{2\pi 40 \text{ k}\Omega f_{c(\text{LPF})}} \quad (6)$$

Substituting 10 kHz for  $f_{c(\text{LPF})}$  and solving for  $C_F$ :

$$C_F = 398 \text{ pF}$$

#### Step 2: High-Pass Filter

$$f_{c(\text{HPF})} = \frac{1}{2\pi R_I C_I}$$

where  $R_I$  is the input resistor (7)

Because the application in this case requires a gain of 4 V/V,  $R_I$  must be set to 10 k $\Omega$ .

Substituting  $R_I$  into Equation 6.

$$f_{c(\text{HPF})} = \frac{1}{2\pi 10 \text{ k}\Omega C_I} \quad (8)$$

Therefore,

$$C_I = \frac{1}{2\pi 10 \text{ k}\Omega f_{c(\text{HPF})}} \quad (9)$$

Substituting 100 Hz for  $f_{c(\text{HPF})}$  and solving for  $C_I$ :

$$C_I = 0.16 \mu\text{F}$$

At this point, a first-order band-pass filter has been created with the low-frequency cutoff set to 100 Hz and the high-frequency cutoff set to 10 kHz.

The process can be taken a step further by creating a second-order high-pass filter. This is accomplished by placing a resistor ( $R_a$ ) and capacitor ( $C_a$ ) in the input path. It is important to note that  $R_a$  must be at least 10 times smaller than  $R_I$ ; otherwise its value has a noticeable effect on the gain, as  $R_a$  and  $R_I$  are in series.

#### Step 3: Additional Low-Pass Filter

$R_a$  must be at least 10X smaller than  $R_I$ , Set  $R_a = 1 \text{ k}\Omega$

$$f_{c(\text{LPF})} = \frac{1}{2\pi R_a C_a} \quad (10)$$

Therefore,

$$C_a = \frac{1}{2\pi \cdot 1\text{k}\Omega \cdot f_{c(\text{LPF})}} \quad (11)$$

Substituting 10 kHz for  $f_{c(\text{LPF})}$  and solving for  $C_a$ :

$$C_a = 160 \text{ pF}$$

Figure 30 is a bode plot for the band-pass filter in the previous example. Figure 29 shows how to configure the TPA6020A2 as a band-pass filter.

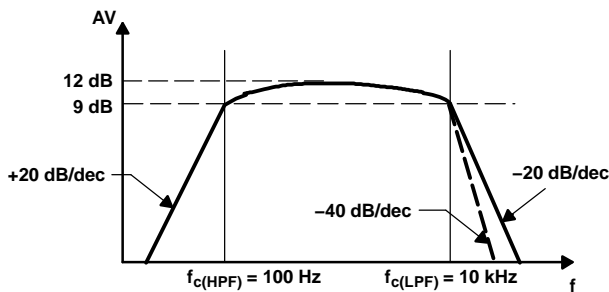

Figure 30. Bode Plot

### Decoupling Capacitor ( $C_S$ )

The TPA6020A2 is a high-performance CMOS audio amplifier that requires adequate power supply decoupling to ensure the output total harmonic distortion (THD) is as low as possible. Power-supply decoupling also prevents oscillations for long lead lengths between the amplifier and the speaker. For higher frequency transients, spikes, or digital hash on the line, a good low equivalent-series-resistance (ESR) ceramic capacitor, typically 0.1  $\mu\text{F}$  to 1  $\mu\text{F}$ , placed as close as possible to the device  $V_{DD}$  lead works best. For filtering lower frequency noise signals, a 10- $\mu\text{F}$  or greater capacitor placed near the audio power amplifier also helps, but is not required in most applications because of the high PSRR of this device.

### USING LOW-ESR CAPACITORS

Low-ESR capacitors are recommended throughout this applications section. A real (as opposed to ideal) capacitor can be modeled simply as a resistor in series with an ideal capacitor. The voltage drop across this resistor minimizes the beneficial effects of the capacitor in the circuit. The lower the equivalent value of this resistance the more the real capacitor behaves like an ideal capacitor.

### DIFFERENTIAL OUTPUT VERSUS SINGLE-ENDED OUTPUT

Figure 31 shows a Class-AB audio power amplifier (APA) in a fully differential configuration. The TPA6020A2 amplifier has differential outputs driving both ends of the load. One of several potential

benefits to this configuration is power to the load. The differential drive to the speaker means that as one side is slewing up, the other side is slewing down, and vice versa. This in effect doubles the voltage swing on the load as compared to a ground-referenced load. Plugging  $2X V_{O(\text{PP})}$  into the power equation, where voltage is squared, yields  $4X$  the output power from the same supply rail and load impedance Equation 12.

$$V_{(\text{rms})} = \frac{V_{O(\text{PP})}}{2\sqrt{2}}$$

$$\text{Power} = \frac{V_{(\text{rms})}^2}{R_L} \quad (12)$$

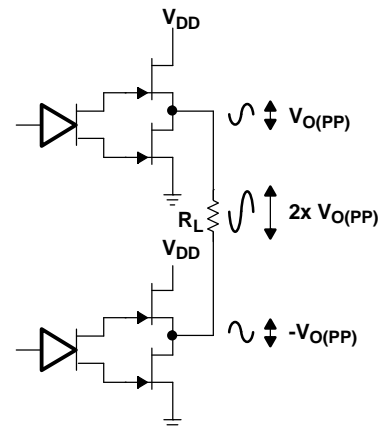
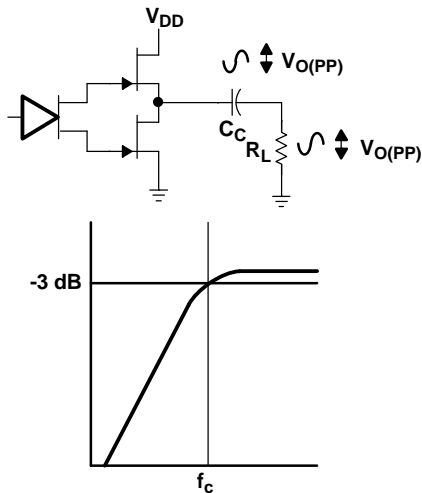

Figure 31. Differential Output Configuration

In a typical wireless handset operating at 3.6 V, bridging raises the power into an 8- $\Omega$  speaker from a singled-ended (SE, ground reference) limit of 200 mW to 800 mW. This is a 6-dB improvement in sound power—loudness that can be heard. In addition to increased power, there are frequency-response concerns. Consider the single-supply SE configuration shown in Figure 32. A coupling capacitor ( $C_C$ ) is required to block the dc-offset voltage from the load. This capacitor can be quite large (approximately 33  $\mu\text{F}$  to 1000  $\mu\text{F}$ ) so it tends to be expensive, heavy, occupy valuable PCB area, and have the additional drawback of limiting low-frequency performance. This frequency-limiting effect is due to the high-pass filter network created with the speaker impedance and the coupling capacitance. This is calculated with Equation 13.

$$f_c = \frac{1}{2\pi R_L C_C} \tag{13}$$

For example, a 68- $\mu$ F capacitor with an 8- $\Omega$  speaker would attenuate low frequencies below 293 Hz. The BTL configuration cancels the dc offsets, which eliminates the need for the blocking capacitors. Low-frequency performance is then limited only by the input network and speaker response. Cost and PCB space are also minimized by eliminating the bulky coupling capacitor.



**Figure 32. Single-Ended Output and Frequency Response**

Increasing power to the load does carry a penalty of increased internal power dissipation. The increased dissipation is understandable considering that the BTL configuration produces 4X the output power of the SE configuration.

**FULLY DIFFERENTIAL AMPLIFIER EFFICIENCY AND THERMAL INFORMATION**

Class-AB amplifiers are inefficient, primarily because of voltage drop across the output-stage transistors. The two components of this internal voltage drop are the headroom or dc voltage drop that varies inversely to output power, and the sine wave nature of the

output. The total voltage drop can be calculated by subtracting the RMS value of the output voltage from  $V_{DD}$ . The internal voltage drop multiplied by the average value of the supply current,  $I_{DD(avg)}$ , determines the internal power dissipation of the amplifier.

An easy-to-use equation to calculate efficiency starts out as being equal to the ratio of power from the power supply to the power delivered to the load. To accurately calculate the RMS and average values of power in the load and in the amplifier, the current and voltage waveform shapes must first be understood (see Figure 33).

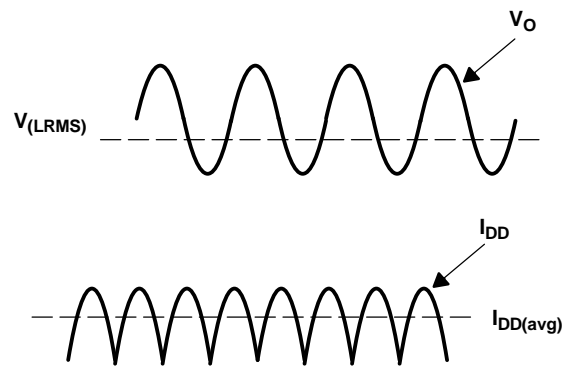

**Figure 33. Voltage and Current Waveforms for BTL Amplifiers**

Although the voltages and currents for SE and BTL are sinusoidal in the load, currents from the supply are different between SE and BTL configurations. In an SE application the current waveform is a half-wave rectified shape, whereas in BTL it is a full-wave rectified waveform. This means RMS conversion factors are different. Keep in mind that for most of the waveform both the push and pull transistors are not on at the same time, which supports the fact that each amplifier in the BTL device only draws current from the supply for half the waveform. The following equations are the basis for calculating amplifier efficiency.

$$\text{Efficiency of a BTL amplifier} = \frac{P_L}{P_{SUP}}$$

Where:

$$P_L = \frac{V_{L\text{rms}}^2}{R_L}, \text{ and } V_{LRMS} = \frac{V_P}{\sqrt{2}}, \text{ therefore, } P_L = \frac{V_P^2}{2R_L}$$

$$\text{and } P_{SUP} = V_{DD} I_{DD\text{avg}} \text{ and } I_{DD\text{avg}} = \frac{1}{\pi} \int_0^\pi \frac{V_P}{R_L} \sin(t) dt = -\frac{1}{\pi} \times \frac{V_P}{R_L} [\cos(t)]_0^\pi = \frac{2V_P}{\pi R_L}$$

Therefore,

$$P_{SUP} = \frac{2 V_{DD} V_P}{\pi R_L}$$

substituting  $P_L$  and  $P_{SUP}$  into equation 6,

$$\text{Efficiency of a BTL amplifier} = \frac{\frac{V_P^2}{2R_L}}{\frac{2 V_{DD} V_P}{\pi R_L}} = \frac{\pi V_P}{4 V_{DD}}$$

Where:

$$V_P = \sqrt{2 P_L R_L}$$

$P_L$  = Power delivered to load  
 $P_{SUP}$  = Power drawn from power supply  
 $V_{LRMS}$  = RMS voltage on BTL load  
 $R_L$  = Load resistance  
 $V_P$  = Peak voltage on BTL load  
 $I_{DD\text{avg}}$  = Average current drawn from the power supply  
 $V_{DD}$  = Power supply voltage  
 $\eta_{BTL}$  = Efficiency of a BTL amplifier

(14)

Therefore,

$$\eta_{BTL} = \frac{\pi \sqrt{2 P_L R_L}}{4 V_{DD}}$$

(15)

**Table 2. Efficiency and Maximum Ambient Temperature vs Output Power**

Output Power (W)	Efficiency (%)	Internal Dissipation (W)	Power From Supply (W)	Max Ambient Temperature (°C)
<b>5-V, Stereo, 3-Ω Systems</b>				
0.5	27.2	2.68	3.68	38
1	38.4	3.20	5.20	17
2	54.4	3.35	7.35	10
2.8	64.4	3.10	8.70	21
<b>5-V, Stereo, 4-Ω BTL Systems</b>				
0.5	31.4	2.18	3.18	59
1	44.4	2.50	4.50	46
2	62.8	2.37	6.37	51
2.5	70.2	2.12	7.12	62
<b>5-V, Stereo, 8-Ω Systems</b>				
0.25	31.4	1.09	1.59	85 <sup>(1)</sup>
0.5	44.4	1.25	2.25	85 <sup>(1)</sup>
1	62.8	1.18	3.18	85 <sup>(1)</sup>
1.36	73.3	0.99	3.71	85 <sup>(1)</sup>

(1) Package limited to 85°C ambient

Table 2 employs Equation 15 to calculate efficiencies for four different output power levels. Note that the efficiency of the amplifier is quite low for lower power levels and rises sharply as power to the load is increased resulting in a nearly flat internal power dissipation over the normal operating range. Note that the internal dissipation at full output power is less than in the half power range. Calculating the efficiency for a specific system is the key to proper power supply design. For a 2.8-W audio system with 3-Ω loads and a 5-V supply, the maximum draw on the power supply is almost 8.8 W.

A final point to remember about Class-AB amplifiers is how to manipulate the terms in the efficiency equation to the utmost advantage when possible. Note that in Equation 15,  $V_{DD}$  is in the denominator. This indicates that as  $V_{DD}$  goes down, efficiency goes up.

A simple formula for calculating the maximum power dissipated,  $P_{Dmax}$ , may be used for a stereo, differential output application:

$$P_{Dmax} = \frac{4 V_{DD}^2}{R_L} \quad (16)$$

$P_{Dmax}$  for a 5-V, 4-Ω system is 2.53 W.

The maximum ambient temperature depends on the heat sinking ability of the PCB system. The derating factor for the 5 mm x 5 mm QFN package is shown in the dissipation rating table. Converting this to  $\theta_{JA}$ :

$$\theta_{JA} = \frac{1}{\text{Derating Factor}} = \frac{1}{0.2398} = 41.7^\circ\text{C/W} \quad (17)$$

Given  $\theta_{JA}$ , the maximum allowable junction temperature, and the maximum internal dissipation, the maximum ambient temperature can be calculated with Equation 18. The maximum recommended junction temperature for the TPA6020A2 is 150°C.

$$\begin{aligned} T_A \text{ Max} &= T_J \text{ Max} - \theta_{JA} P_D \text{ Max} \\ &= 150 - 41.7(2.53) = 44.5^\circ\text{C/W} \end{aligned} \quad (18)$$

Equation 18 shows that the maximum ambient temperature is 44.5°C at maximum power dissipation with a 5-V supply.

Table 2 shows that for most applications no airflow is required to keep junction temperatures in the specified range. The TPA6020A2 is designed with thermal protection that turns the device off when the junction temperature surpasses 150°C to prevent damage to the IC. In addition, using speakers with an impedance higher than 4 Ω dramatically increases the thermal performance by reducing the output current.

The TPA6020A2 is capable of driving impedances as low as 3 Ω, but special layout techniques must be considered in order to achieve optimal performance. In a 5-V, 3-Ω stereo system, the maximum ambient temperature is just 9.1°C. To increase the maximum ambient temperature,  $\theta_{JA}$  has to be reduced. This is achieved by increasing the amount of copper on the board. Using 3 oz. or 4 oz. copper, and/or additional layers, increases the thermal performance of the device.

**PACKAGING INFORMATION**

Orderable Device	Status (1)	Package Type	Package Drawing	Pins	Package Qty	Eco Plan (2)	Lead/Ball Finish (6)	MSL Peak Temp (3)	Op Temp (°C)	Device Marking (4/5)	Samples
TPA6020A2RGWR	ACTIVE	VQFN	RGW	20	3000	Green (RoHS & no Sb/Br)	CU NIPDAU	Level-2-260C-1 YEAR	-40 to 85	TPA 6020A2	<a href="#">Samples</a>
TPA6020A2RGWRG4	ACTIVE	VQFN	RGW	20	3000	Green (RoHS & no Sb/Br)	CU NIPDAU	Level-2-260C-1 YEAR	-40 to 85	TPA 6020A2	<a href="#">Samples</a>
TPA6020A2RGWT	ACTIVE	VQFN	RGW	20	250	Green (RoHS & no Sb/Br)	CU NIPDAU	Level-2-260C-1 YEAR	-40 to 85	TPA 6020A2	<a href="#">Samples</a>

(1) The marketing status values are defined as follows:

**ACTIVE:** Product device recommended for new designs.

**LIFEBUY:** TI has announced that the device will be discontinued, and a lifetime-buy period is in effect.

**NRND:** Not recommended for new designs. Device is in production to support existing customers, but TI does not recommend using this part in a new design.

**PREVIEW:** Device has been announced but is not in production. Samples may or may not be available.

**OBsolete:** TI has discontinued the production of the device.

(2) Eco Plan - The planned eco-friendly classification: Pb-Free (RoHS), Pb-Free (RoHS Exempt), or Green (RoHS & no Sb/Br) - please check <http://www.ti.com/productcontent> for the latest availability information and additional product content details.

**TBD:** The Pb-Free/Green conversion plan has not been defined.

**Pb-Free (RoHS):** TI's terms "Lead-Free" or "Pb-Free" mean semiconductor products that are compatible with the current RoHS requirements for all 6 substances, including the requirement that lead not exceed 0.1% by weight in homogeneous materials. Where designed to be soldered at high temperatures, TI Pb-Free products are suitable for use in specified lead-free processes.

**Pb-Free (RoHS Exempt):** This component has a RoHS exemption for either 1) lead-based flip-chip solder bumps used between the die and package, or 2) lead-based die adhesive used between the die and leadframe. The component is otherwise considered Pb-Free (RoHS compatible) as defined above.

**Green (RoHS & no Sb/Br):** TI defines "Green" to mean Pb-Free (RoHS compatible), and free of Bromine (Br) and Antimony (Sb) based flame retardants (Br or Sb do not exceed 0.1% by weight in homogeneous material)

(3) MSL, Peak Temp. - The Moisture Sensitivity Level rating according to the JEDEC industry standard classifications, and peak solder temperature.

(4) There may be additional marking, which relates to the logo, the lot trace code information, or the environmental category on the device.

(5) Multiple Device Markings will be inside parentheses. Only one Device Marking contained in parentheses and separated by a "~" will appear on a device. If a line is indented then it is a continuation of the previous line and the two combined represent the entire Device Marking for that device.

(6) Lead/Ball Finish - Orderable Devices may have multiple material finish options. Finish options are separated by a vertical ruled line. Lead/Ball Finish values may wrap to two lines if the finish value exceeds the maximum column width.

**Important Information and Disclaimer:** The information provided on this page represents TI's knowledge and belief as of the date that it is provided. TI bases its knowledge and belief on information provided by third parties, and makes no representation or warranty as to the accuracy of such information. Efforts are underway to better integrate information from third parties. TI has taken and

continues to take reasonable steps to provide representative and accurate information but may not have conducted destructive testing or chemical analysis on incoming materials and chemicals. TI and TI suppliers consider certain information to be proprietary, and thus CAS numbers and other limited information may not be available for release.

In no event shall TI's liability arising out of such information exceed the total purchase price of the TI part(s) at issue in this document sold by TI to Customer on an annual basis.

**TAPE AND REEL INFORMATION**

**REEL DIMENSIONS**

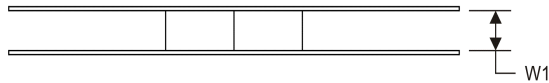
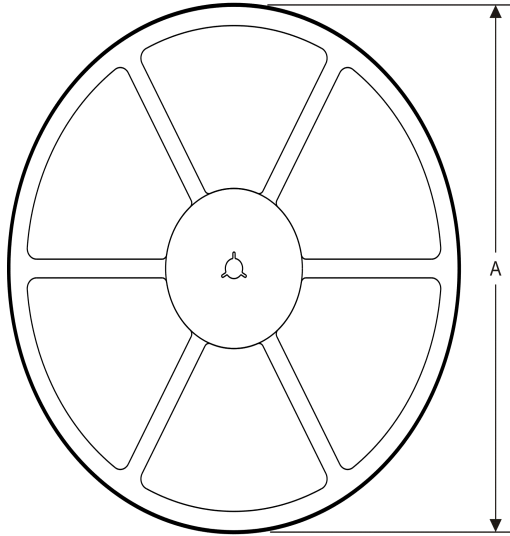

**TAPE DIMENSIONS**

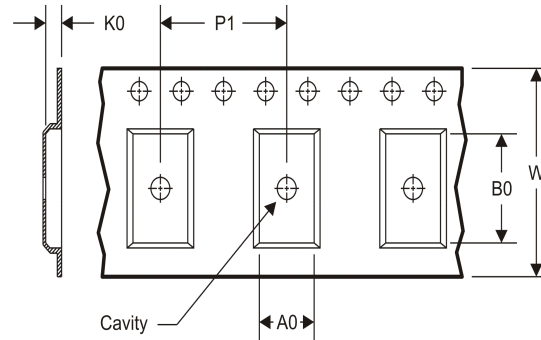

A0	Dimension designed to accommodate the component width
B0	Dimension designed to accommodate the component length
K0	Dimension designed to accommodate the component thickness
W	Overall width of the carrier tape
P1	Pitch between successive cavity centers

**TAPE AND REEL INFORMATION**

\*All dimensions are nominal

Device	Package Type	Package Drawing	Pins	SPQ	Reel Diameter (mm)	Reel Width W1 (mm)	A0 (mm)	B0 (mm)	K0 (mm)	P1 (mm)	W (mm)	Pin1 Quadrant
TPA6020A2RGWR	VQFN	RGW	20	3000	330.0	12.4	5.3	5.3	1.5	8.0	12.0	Q2
TPA6020A2RGWT	VQFN	RGW	20	250	180.0	12.4	5.3	5.3	1.5	8.0	12.0	Q2

TAPE AND REEL BOX DIMENSIONS



\*All dimensions are nominal

Device	Package Type	Package Drawing	Pins	SPQ	Length (mm)	Width (mm)	Height (mm)
TPA6020A2RGWR	VQFN	RGW	20	3000	367.0	367.0	35.0
TPA6020A2RGWT	VQFN	RGW	20	250	210.0	185.0	35.0

# MECHANICAL DATA

RGW (S-PVQFN-N20)

PLASTIC QUAD FLATPACK NO-LEAD

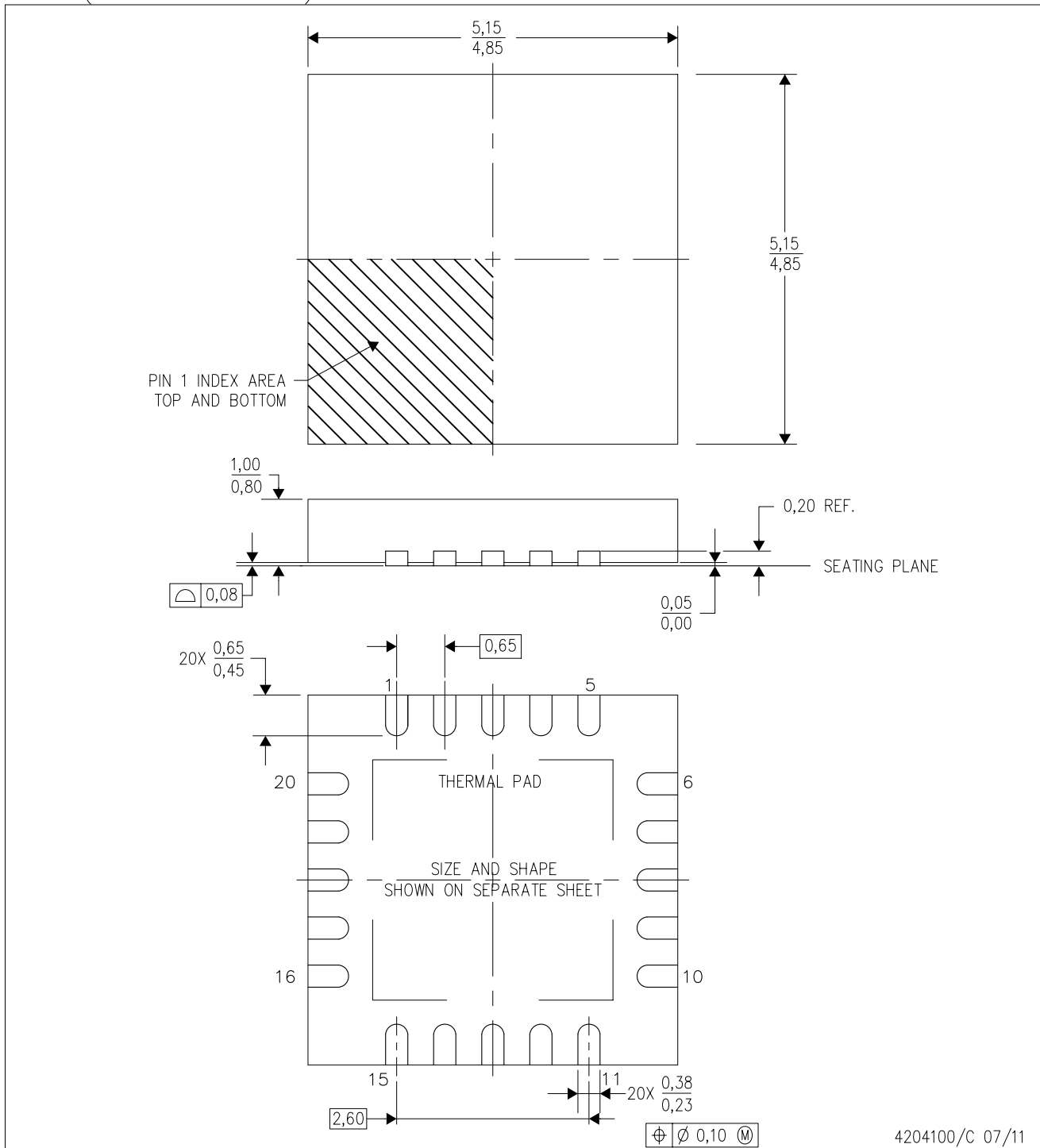

- NOTES:
- All linear dimensions are in millimeters. Dimensioning and tolerancing per ASME Y14.5-1994.
  - This drawing is subject to change without notice.
  - Quad Flat pack, No-leads (QFN) package configuration
  - The package thermal pad must be soldered to the board for thermal and mechanical performance.
  - See the additional figure in the Product Data Sheet for details regarding the exposed thermal pad features and dimensions.
  - Falls within JEDEC MO-220.



RGW (S-PVQFN-N20)

PLASTIC QUAD FLATPACK NO-LEAD

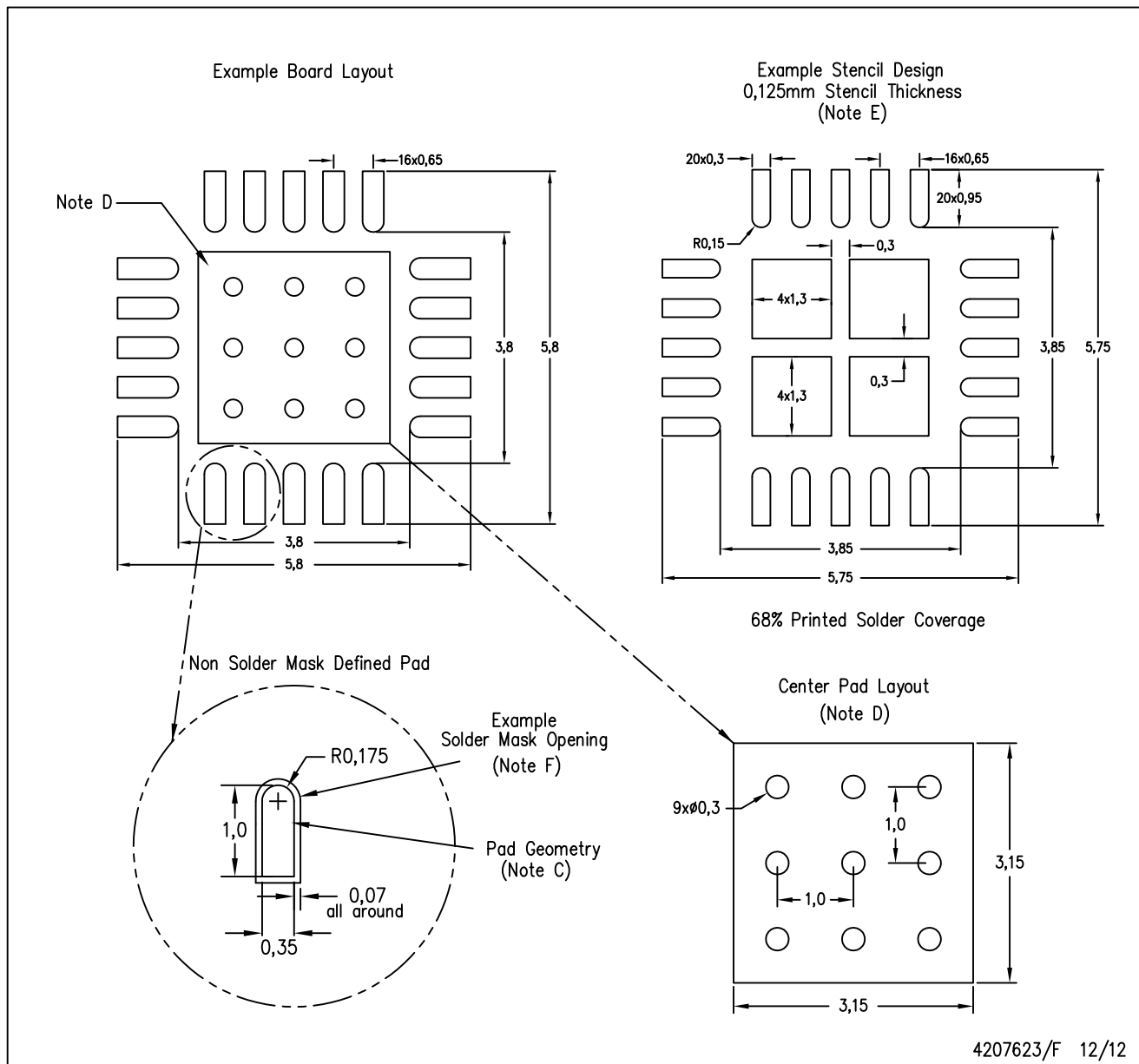

- NOTES:
- All linear dimensions are in millimeters.
  - This drawing is subject to change without notice.
  - Publication IPC-7351 is recommended for alternate designs.
  - This package is designed to be soldered to a thermal pad on the board. Refer to Application Note, QFN Packages, Texas Instruments Literature No. SLUA271, and also the Product Data Sheets for specific thermal information, via requirements, and recommended board layout. These documents are available at [www.ti.com](http://www.ti.com) <<http://www.ti.com>>.
  - Laser cutting apertures with trapezoidal walls and also rounding corners will offer better paste release. Customers should contact their board assembly site for stencil design recommendations. Refer to IPC 7525 for stencil design considerations.
  - Customers should contact their board fabrication site for solder mask tolerances.

## IMPORTANT NOTICE

Texas Instruments Incorporated and its subsidiaries (TI) reserve the right to make corrections, enhancements, improvements and other changes to its semiconductor products and services per JESD46, latest issue, and to discontinue any product or service per JESD48, latest issue. Buyers should obtain the latest relevant information before placing orders and should verify that such information is current and complete. All semiconductor products (also referred to herein as "components") are sold subject to TI's terms and conditions of sale supplied at the time of order acknowledgment.

TI warrants performance of its components to the specifications applicable at the time of sale, in accordance with the warranty in TI's terms and conditions of sale of semiconductor products. Testing and other quality control techniques are used to the extent TI deems necessary to support this warranty. Except where mandated by applicable law, testing of all parameters of each component is not necessarily performed.

TI assumes no liability for applications assistance or the design of Buyers' products. Buyers are responsible for their products and applications using TI components. To minimize the risks associated with Buyers' products and applications, Buyers should provide adequate design and operating safeguards.

TI does not warrant or represent that any license, either express or implied, is granted under any patent right, copyright, mask work right, or other intellectual property right relating to any combination, machine, or process in which TI components or services are used. Information published by TI regarding third-party products or services does not constitute a license to use such products or services or a warranty or endorsement thereof. Use of such information may require a license from a third party under the patents or other intellectual property of the third party, or a license from TI under the patents or other intellectual property of TI.

Reproduction of significant portions of TI information in TI data books or data sheets is permissible only if reproduction is without alteration and is accompanied by all associated warranties, conditions, limitations, and notices. TI is not responsible or liable for such altered documentation. Information of third parties may be subject to additional restrictions.

Resale of TI components or services with statements different from or beyond the parameters stated by TI for that component or service voids all express and any implied warranties for the associated TI component or service and is an unfair and deceptive business practice. TI is not responsible or liable for any such statements.

Buyer acknowledges and agrees that it is solely responsible for compliance with all legal, regulatory and safety-related requirements concerning its products, and any use of TI components in its applications, notwithstanding any applications-related information or support that may be provided by TI. Buyer represents and agrees that it has all the necessary expertise to create and implement safeguards which anticipate dangerous consequences of failures, monitor failures and their consequences, lessen the likelihood of failures that might cause harm and take appropriate remedial actions. Buyer will fully indemnify TI and its representatives against any damages arising out of the use of any TI components in safety-critical applications.

In some cases, TI components may be promoted specifically to facilitate safety-related applications. With such components, TI's goal is to help enable customers to design and create their own end-product solutions that meet applicable functional safety standards and requirements. Nonetheless, such components are subject to these terms.

No TI components are authorized for use in FDA Class III (or similar life-critical medical equipment) unless authorized officers of the parties have executed a special agreement specifically governing such use.

Only those TI components which TI has specifically designated as military grade or "enhanced plastic" are designed and intended for use in military/aerospace applications or environments. Buyer acknowledges and agrees that any military or aerospace use of TI components which have **not** been so designated is solely at the Buyer's risk, and that Buyer is solely responsible for compliance with all legal and regulatory requirements in connection with such use.

TI has specifically designated certain components as meeting ISO/TS16949 requirements, mainly for automotive use. In any case of use of non-designated products, TI will not be responsible for any failure to meet ISO/TS16949.

### Products

Audio	<a href="http://www.ti.com/audio">www.ti.com/audio</a>
Amplifiers	<a href="http://amplifier.ti.com">amplifier.ti.com</a>
Data Converters	<a href="http://dataconverter.ti.com">dataconverter.ti.com</a>
DLP® Products	<a href="http://www.dlp.com">www.dlp.com</a>
DSP	<a href="http://dsp.ti.com">dsp.ti.com</a>
Clocks and Timers	<a href="http://www.ti.com/clocks">www.ti.com/clocks</a>
Interface	<a href="http://interface.ti.com">interface.ti.com</a>
Logic	<a href="http://logic.ti.com">logic.ti.com</a>
Power Mgmt	<a href="http://power.ti.com">power.ti.com</a>
Microcontrollers	<a href="http://microcontroller.ti.com">microcontroller.ti.com</a>
RFID	<a href="http://www.ti-rfid.com">www.ti-rfid.com</a>
OMAP Applications Processors	<a href="http://www.ti.com/omap">www.ti.com/omap</a>
Wireless Connectivity	<a href="http://www.ti.com/wirelessconnectivity">www.ti.com/wirelessconnectivity</a>

### Applications

Automotive and Transportation	<a href="http://www.ti.com/automotive">www.ti.com/automotive</a>
Communications and Telecom	<a href="http://www.ti.com/communications">www.ti.com/communications</a>
Computers and Peripherals	<a href="http://www.ti.com/computers">www.ti.com/computers</a>
Consumer Electronics	<a href="http://www.ti.com/consumer-apps">www.ti.com/consumer-apps</a>
Energy and Lighting	<a href="http://www.ti.com/energy">www.ti.com/energy</a>
Industrial	<a href="http://www.ti.com/industrial">www.ti.com/industrial</a>
Medical	<a href="http://www.ti.com/medical">www.ti.com/medical</a>
Security	<a href="http://www.ti.com/security">www.ti.com/security</a>
Space, Avionics and Defense	<a href="http://www.ti.com/space-avionics-defense">www.ti.com/space-avionics-defense</a>
Video and Imaging	<a href="http://www.ti.com/video">www.ti.com/video</a>

### TI E2E Community

[e2e.ti.com](http://e2e.ti.com)