

TPS3700 High voltage (18V) window voltage detector with internal reference for over and undervoltage monitoring

1 Features

- Wide supply voltage range: 1.8 V to 18 V
- Adjustable threshold: down to 400 mV
- High threshold accuracy:
 - 1.0% over temperature
 - 0.25% (Typical)
- Low quiescent current: 5.5 μ A (Typical)
- Open-drain outputs for overvoltage and undervoltage detection
- Internal hysteresis: 5.5 mV (Typ)
- Temperature range: -40°C to 125°C
- Packages:
 - SOT-6
 - 1.5-mm \times 1.5-mm WSON-6

2 Applications

- Industrial control systems
- Automotive systems
- Embedded computing modules
- DSP, microcontroller, or microprocessor applications
- Notebook and desktop computers
- Portable- and battery-powered products
- FPGA and ASIC applications

3 Description

The TPS3700 wide-supply window voltage detector operates over a 1.8-V to 18-V range. The device has two high-accuracy comparators with an internal 400-mV reference and two open-drain outputs rated to 18 V for over- and undervoltage detection. The TPS3700 can be used as a window voltage detector or as two independent voltage monitors; the monitored voltage can be set with the use of external resistors.

OUTA is driven low when the voltage at INA+ drops below $(V_{ITP} - V_{HYS})$, and goes high when the voltage returns above the respective threshold (V_{ITP}) . OUTB is driven low when the voltage at INB- rises above V_{ITP} , and goes high when the voltage drops below the respective threshold $(V_{ITP} - V_{HYS})$. Both comparators in the TPS3700 include built-in hysteresis for filtering to reject brief glitches, thereby ensuring stable output operation without false triggering.

The TPS3700 is available in a SOT-6 and a 1.5-mm \times 1.5-mm WSON-6 package and is specified over the junction temperature range of -40°C to 125°C .

Device Information⁽¹⁾

PART NUMBER	PACKAGE	BODY SIZE (NOM)
TPS3700	SOT (6)	2.90 mm \times 1.60 mm
	WSON (6)	1.50 mm \times 1.50 mm

(1) For all available packages, see the orderable addendum at the end of the datasheet.

Simplified Schematic

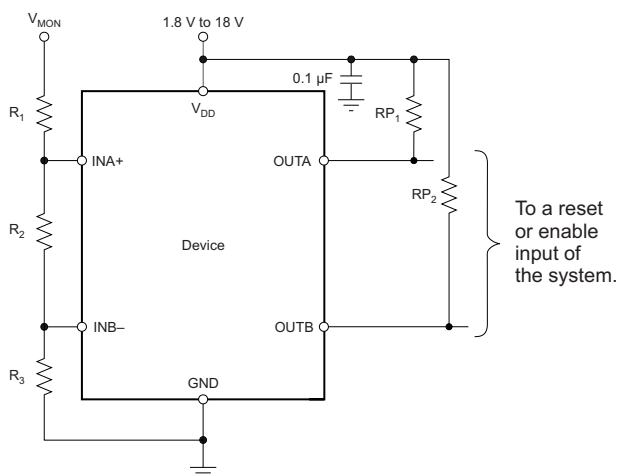

Output vs Input Thresholds and Hysteresis

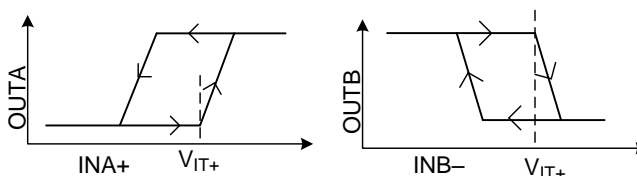

Table of Contents

1 Features	1	7.4 Device Functional Modes.....	12
2 Applications	1	8 Application and Implementation	13
3 Description	1	8.1 Application Information.....	13
4 Revision History	3	8.2 Typical Application	16
5 Pin Configuration and Functions	4	8.3 Do's and Don'ts.....	18
6 Specifications	5	9 Power-Supply Recommendations	19
6.1 Absolute Maximum Ratings	5	10 Layout	19
6.2 ESD Ratings.....	5	10.1 Layout Guidelines	19
6.3 Recommended Operating Conditions.....	5	10.2 Layout Example	19
6.4 Thermal Information	5	11 Device and Documentation Support	20
6.5 Electrical Characteristics.....	6	11.1 Device Support.....	20
6.6 Timing Requirements	7	11.2 Documentation Support	20
6.7 Switching Characteristics	7	11.3 Receiving Notification of Documentation Updates	20
6.8 Typical Characteristics	8	11.4 Community Resources.....	20
7 Detailed Description	10	11.5 Trademarks	20
7.1 Overview	10	11.6 Electrostatic Discharge Caution.....	20
7.2 Functional Block Diagram	10	11.7 Glossary	21
7.3 Feature Description.....	10	12 Mechanical, Packaging, and Orderable Information	21

4 Revision History

NOTE: Page numbers for previous revisions may differ from page numbers in the current version.

Changes from Revision F (January 2018) to Revision G Page

- Changed comparator to voltage detector throughout datasheet 1
-

Changes from Revision E (February 2017) to Revision F Page

- Changed comparator to supervisor throughout datasheet 1
-

Changes from Revision D (January 2015) to Revision E Page

- Added maximum specification to *Start-up delay* parameter 6
 - Changed *at least 150 μs* to *450 μs (max)* in footnote 2 of *Electrical Characteristics* table 6
-

Changes from Revision C (May 2013) to Revision D Page

- Added *ESD Ratings* table, *Feature Description* section, *Device Functional Modes, Application and Implementation* section, *Power Supply Recommendations* section, *Layout* section, *Device and Documentation Support* section, and *Mechanical, Packaging, and Orderable Information* section 5
 - Changed HBM maximum specification from 2 kV to 2.5 kV in [ESD Ratings](#) 5
 - Changed [Functional Block Diagram](#); added hysteresis symbol 10
-

Changes from Revision B (April 2012) to Revision C Page

- Changed *Packages Features* bullet 1
 - Added SON-6 package option to *Description* section 1
 - Added DSE pin out graphic to front page 1
 - Added DSE pin out graphic 4
 - Added DSE package to *Thermal Information* table 5
-

Changes from Revision A (February 2012) to Revision B Page

- Moved to *Production Data* 1
-

5 Pin Configuration and Functions

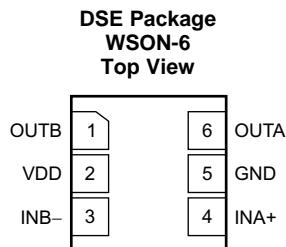
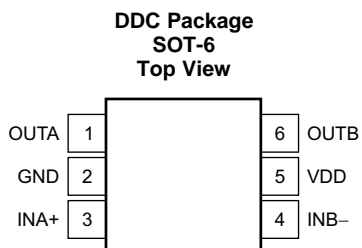

Pin Functions

NAME	PIN		I/O	DESCRIPTION
	DDC	DSE		
GND	2	5	—	Ground
INA+	3	4	I	This pin is connected to the voltage to be monitored with the use of an external resistor divider. When the voltage at this terminal drops below the threshold voltage ($V_{ITP} - V_{HYS}$), OUTA is driven low.
INB-	4	3	I	This pin is connected to the voltage to be monitored with the use of an external resistor divider. When the voltage at this terminal exceeds the threshold voltage (V_{ITP}), OUTB is driven low.
OUTA	1	6	O	INA+ comparator open-drain output. OUTA is driven low when the voltage at this comparator is below ($V_{ITP} - V_{HYS}$). The output goes high when the sense voltage returns above the respective threshold (V_{ITP}).
OUTB	6	1	O	INB- comparator open-drain output. OUTB is driven low when the voltage at this comparator exceeds V_{ITP} . The output goes high when the sense voltage returns below the respective threshold ($V_{ITP} - V_{HYS}$).
VDD	5	2	I	Supply voltage input. Connect a 1.8-V to 18-V supply to VDD to power the device. Good analog design practice is to place a 0.1- μ F ceramic capacitor close to this pin.

6 Specifications

6.1 Absolute Maximum Ratings

over operating temperature range (unless otherwise noted)⁽¹⁾

		MIN	MAX	UNIT
Voltage ⁽²⁾	V _{DD}	-0.3	20	V
	OUTA, OUTB	-0.3	20	V
	INA+, INB-	-0.3	7	V
Current	Output terminal current		40	mA
Operating junction temperature, T _J		-40	125	°C
Storage temperature, T _{stg}		-65	150	°C

- (1) Stresses beyond those listed under *Absolute Maximum Ratings* may cause permanent damage to the device. These are stress ratings only, which do not imply functional operation of the device at these or any other conditions beyond those indicated under *Recommended Operating Conditions*. Exposure to absolute-maximum-rated conditions for extended periods may affect device reliability.
- (2) All voltages are with respect to network ground terminal.

6.2 ESD Ratings

		VALUE	UNIT
V _(ESD) Electrostatic discharge	Human body model (HBM), per ANSI/ESDA/JEDEC JS-001, all pins ⁽¹⁾	±2500	V
	Charged device model (CDM), per JEDEC specification JESD22-C101, all pins ⁽²⁾	±1000	

- (1) JEDEC document JEP155 states that 500-V HBM allows safe manufacturing with a standard ESD control process.
- (2) JEDEC document JEP157 states that 250-V CDM allows safe manufacturing with a standard ESD control process.

6.3 Recommended Operating Conditions

over operating temperature range (unless otherwise noted)

		MIN	NOM	MAX	UNIT
V _{DD}	Supply voltage	1.8		18	V
V _I	Input voltage	0		6.5	V
V _O	Output voltage	0		18	V

6.4 Thermal Information

THERMAL METRIC ⁽¹⁾		TPS3700		UNIT
		DDC (SOT)	DSE (WSON)	
		6 PINS	6 PINS	
R _{θJA}	Junction-to-ambient thermal resistance	204.6	194.9	°C/W
R _{θJC(top)}	Junction-to-case (top) thermal resistance	50.5	128.9	°C/W
R _{θJB}	Junction-to-board thermal resistance	54.3	153.8	°C/W
ψ _{JT}	Junction-to-top characterization parameter	0.8	11.9	°C/W
ψ _{JB}	Junction-to-board characterization parameter	52.8	157.4	°C/W
R _{θJC(bot)}	Junction-to-case (bottom) thermal resistance	N/A	N/A	°C/W

- (1) For more information about traditional and new thermal metrics, see the [Semiconductor and IC Package Thermal Metrics](#) application report.

6.5 Electrical Characteristics

Over the operating temperature range of $T_J = -40^{\circ}\text{C}$ to 125°C , and $1.8\text{ V} < V_{DD} < 18\text{ V}$, unless otherwise noted. Typical values are at $T_J = 25^{\circ}\text{C}$ and $V_{DD} = 5\text{ V}$.

PARAMETER		TEST CONDITIONS	MIN	TYP	MAX	UNIT
V_{DD}	Supply voltage range		1.8		18	V
$V_{(POR)}$	Power-on reset voltage ⁽¹⁾	$V_{OLmax} = 0.2\text{ V}$, $I_{(OUTA/B)} = 15\text{ }\mu\text{A}$			0.8	V
V_{IT+}	Positive-going input threshold voltage	$V_{DD} = 1.8\text{ V}$	396	400	404	mV
		$V_{DD} = 18\text{ V}$	396	400	404	
V_{IT-}	Negative-going input threshold voltage	$V_{DD} = 1.8\text{ V}$	387	394.5	400	mV
		$V_{DD} = 18\text{ V}$	387	394.5	400	
V_{hys}	Hysteresis voltage ($hys = V_{IT+} - V_{IT-}$)			5.5	12	
$I_{(INA+)}$	Input current (at the INA+ terminal)	$V_{DD} = 1.8\text{ V}$ and 18 V , $V_I = 6.5\text{ V}$	-25	1	25	nA
$I_{(INB-)}$	Input current (at the INB- terminal)	$V_{DD} = 1.8\text{ V}$ and 18 V , $V_I = 0.1\text{ V}$	-15	1	15	nA
V_{OL}	Low-level output voltage	$V_{DD} = 1.3\text{ V}$, $I_O = 0.4\text{ mA}$			250	mV
		$V_{DD} = 1.8\text{ V}$, $I_O = 3\text{ mA}$			250	
		$V_{DD} = 5\text{ V}$, $I_O = 5\text{ mA}$			250	
$I_{(kg(OD))}$	Open-drain output leakage-current	$V_{DD} = 1.8\text{ V}$ and 18 V , $V_O = V_{DD}$			300	nA
		$V_{DD} = 1.8\text{ V}$, $V_O = 18\text{ V}$			300	
I_{DD}	Supply current	$V_{DD} = 1.8\text{ V}$, no load		5.5	11	μA
		$V_{DD} = 5\text{ V}$		6	13	
		$V_{DD} = 12\text{ V}$		6	13	
		$V_{DD} = 18\text{ V}$		7	13	
	Start-up delay ⁽²⁾			150	450	μs
UVLO	Undervoltage lockout ⁽³⁾	V_{DD} falling	1.3		1.7	V

(1) The lowest supply voltage (V_{DD}) at which output is active; $t_{r(VDD)} > 15\text{ }\mu\text{s/V}$. Below $V_{(POR)}$, the output cannot be determined.

(2) During power on, V_{DD} must exceed 1.8 V for $450\text{ }\mu\text{s}$ (max) before the output is in a correct state.

(3) When V_{DD} falls below UVLO, OUTA is driven low and OUTB goes to high impedance. The outputs cannot be determined below $V_{(POR)}$.

6.6 Timing Requirements

over operating temperature range (unless otherwise noted)

			MIN	NOM	MAX	UNIT
t_{PHL}	High-to-low propagation delay ⁽¹⁾	$V_{DD} = 5\text{ V}$, 10-mV input overdrive, $R_P = 10\text{ k}\Omega$, $V_{OH} = 0.9 \times V_{DD}$, $V_{OL} = 400\text{ mV}$, see Figure 1		18		μs
t_{PLH}	Low-to-high propagation delay ⁽¹⁾	$V_{DD} = 5\text{ V}$, 10-mV input overdrive, $R_P = 10\text{ k}\Omega$, $V_{OH} = 0.9 \times V_{DD}$, $V_{OL} = 400\text{ mV}$, see Figure 1		29		μs

(1) High-to-low and low-to-high refers to the transition at the input terminals (INA+ and INB-).

6.7 Switching Characteristics

Over operating temperature range (unless otherwise noted)

PARAMETER	TEST CONDITIONS	MIN	TYP	MAX	UNIT
t_r	Output rise time $V_{DD} = 5\text{ V}$, 10-mV input overdrive, $R_P = 10\text{ k}\Omega$, $V_O = (0.1\text{ to }0.9) \times V_{DD}$		2.2		μs
t_f	Output fall time $V_{DD} = 5\text{ V}$, 10-mV input overdrive, $R_P = 10\text{ k}\Omega$, $V_O = (0.1\text{ to }0.9) \times V_{DD}$		0.22		μs

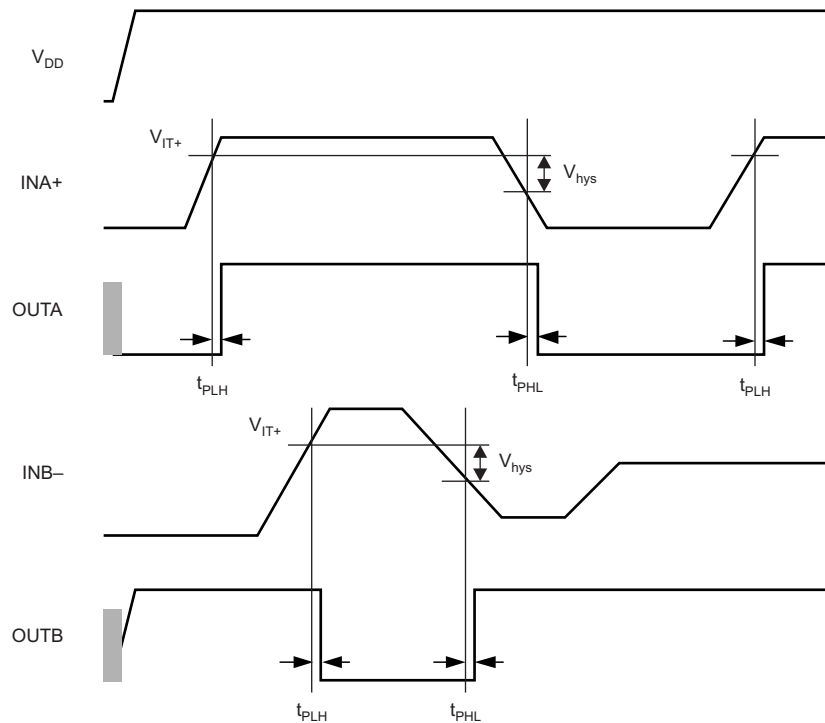

Figure 1. Timing Diagram

6.8 Typical Characteristics

at $T_J = 25^\circ\text{C}$ and $V_{DD} = 5\text{ V}$ (unless otherwise noted)

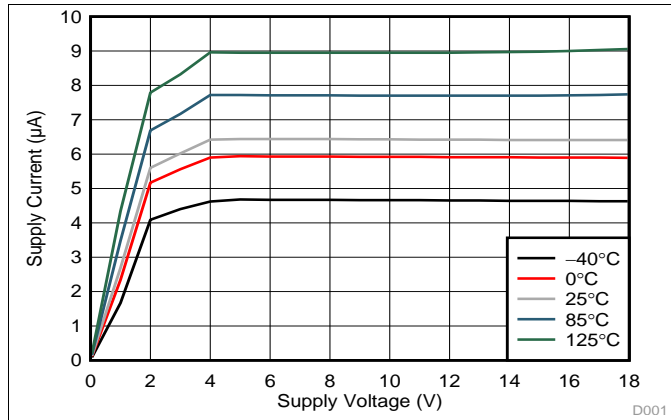

Figure 2. Supply Current (I_{DD}) vs Supply Voltage (V_{DD})

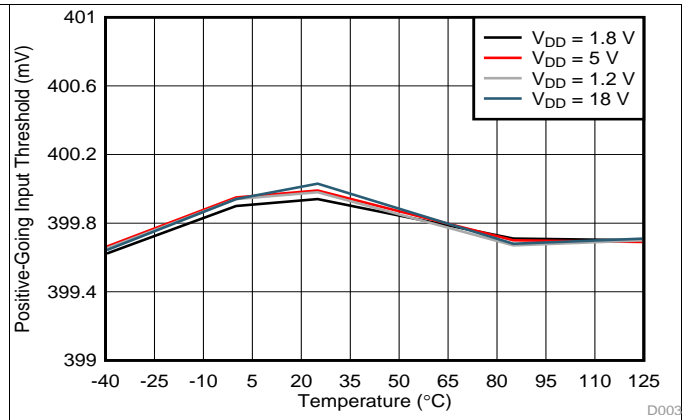

Figure 3. Rising Input Threshold Voltage (V_{IT+}) vs Temperature

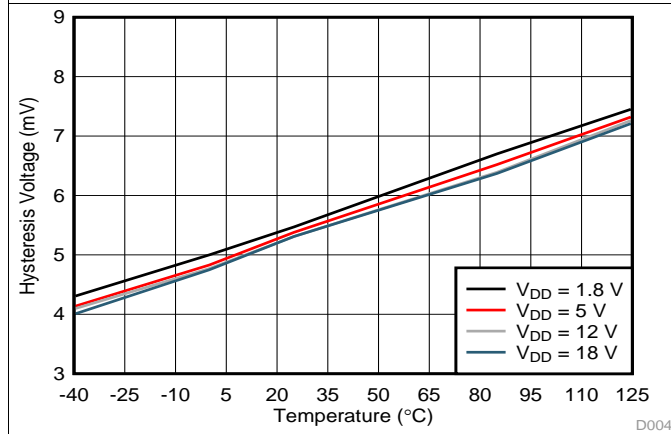

Figure 4. Hysteresis (V_{hys}) vs Temperature

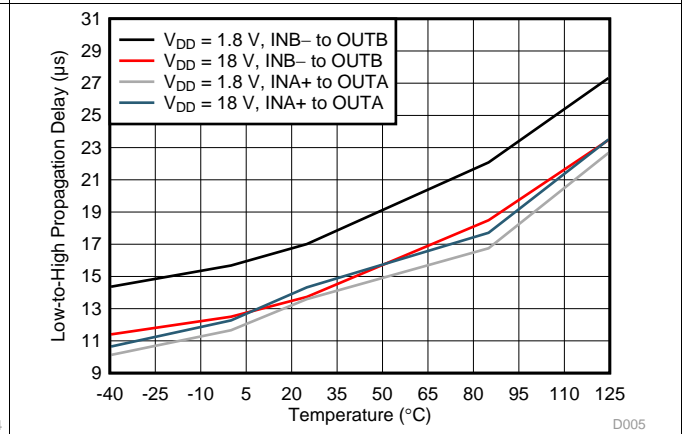

Figure 5. Propagation Delay vs Temperature (High-to-Low Transition at the Inputs)

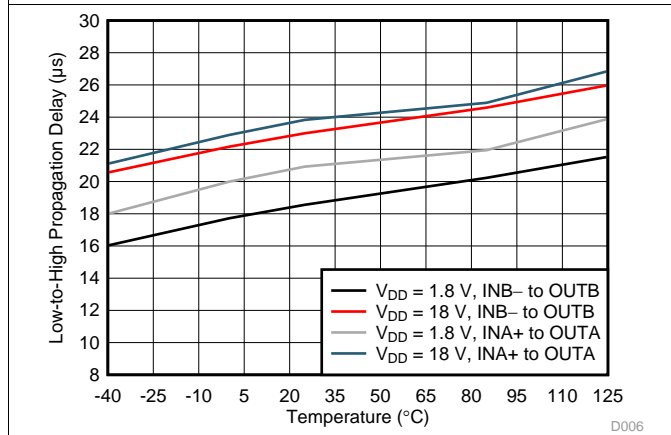
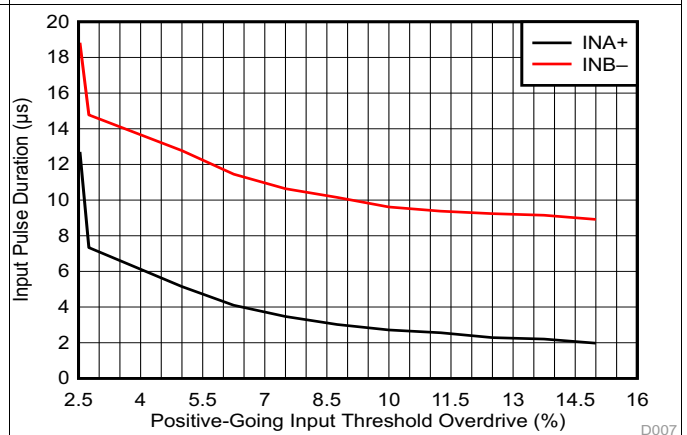

Figure 6. Propagation Delay vs Temperature (Low-to-High Transition at the Inputs)



INA+ = negative spike below V_{IT-}
 INB- = positive spike above V_{IT+}

Figure 7. Minimum Pulse Duration vs Threshold Overdrive Voltage

Typical Characteristics (continued)

at $T_J = 25^\circ\text{C}$ and $V_{DD} = 5\text{ V}$ (unless otherwise noted)

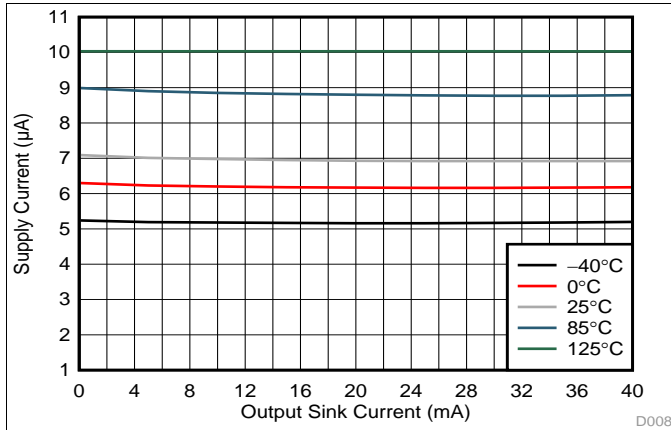

Figure 8. Supply Current (I_{DD}) vs Output Sink Current

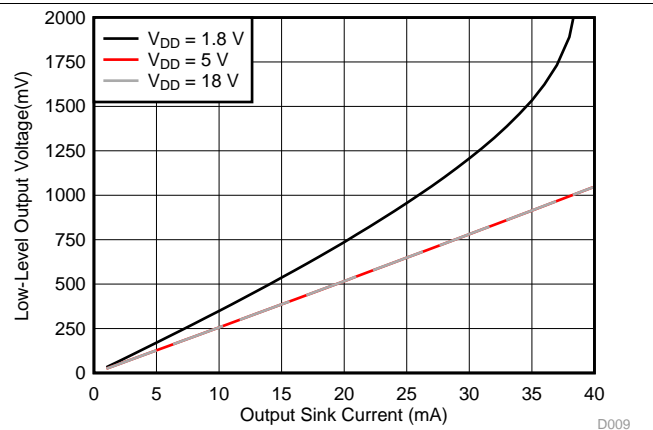

Figure 9. Output Voltage Low (V_{OL}) vs Output Sink Current (-40°C)

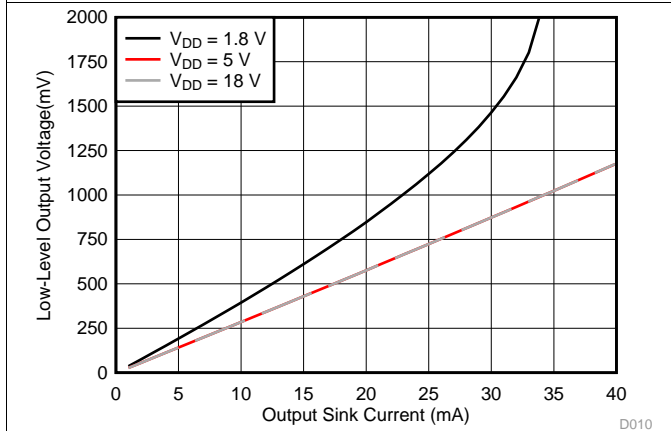

Figure 10. Output Voltage Low (V_{OL}) vs Output Sink Current (0°C)

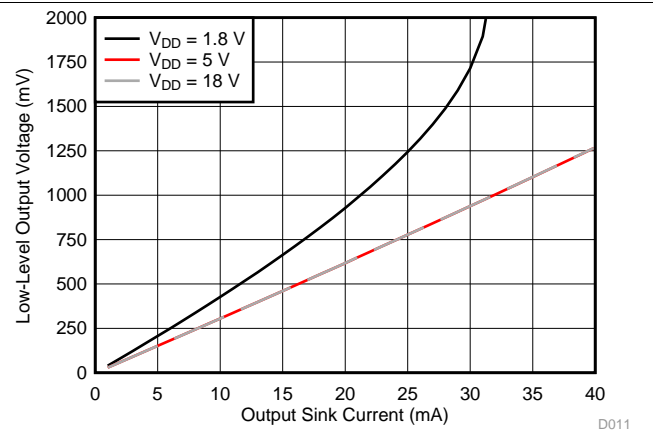

Figure 11. Output Voltage Low (V_{OL}) vs Output Sink Current (25°C)

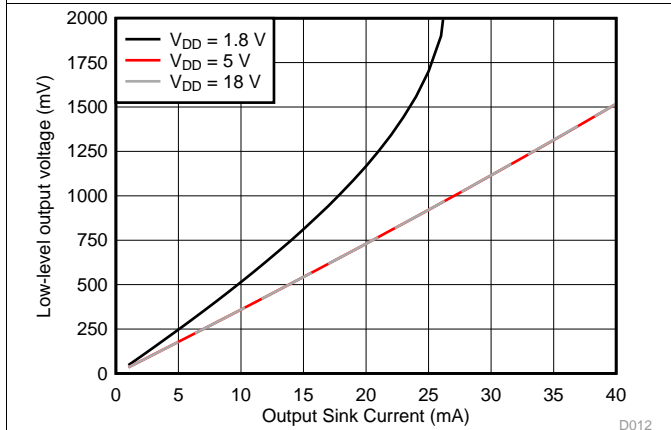

Figure 12. Output Voltage Low (V_{OL}) vs Output Sink Current (85°C)

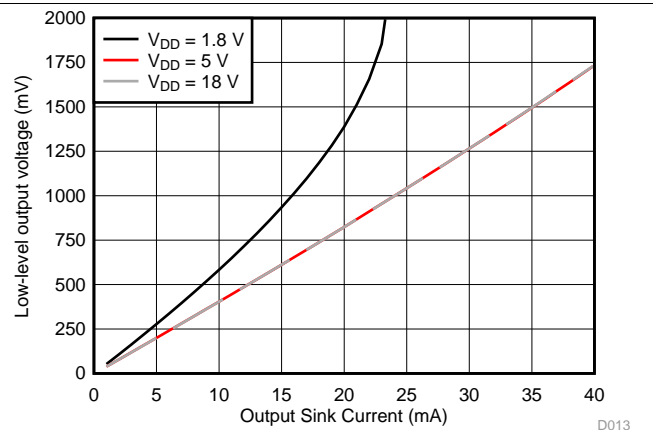

Figure 13. Output Voltage Low (V_{OL}) vs Output Sink Current (125°C)

7 Detailed Description

7.1 Overview

The TPS3700 device combines two voltage detectors for overvoltage and undervoltage detection. The TPS3700 device is a wide-supply voltage range (1.8 V to 18 V) device with a high-accuracy rising input threshold of 400 mV (1% over temperature) and built-in hysteresis. The outputs are also rated to 18 V and can sink up to 40 mA.

The TPS3700 device is designed to assert the output signals, as shown in Table 1. Each input terminal can be set to monitor any voltage above 0.4 V using an external resistor divider network. With the use of two input terminals of different polarities, the TPS3700 device forms a window voltage detector. Broad voltage thresholds can be supported that allow the device to be used in a wide array of applications.

Table 1. TPS3700 Truth Table

CONDITION	OUTPUT	STATUS
$INA+ > V_{IT+}$	OUTA high	Output A not asserted
$INA+ < V_{IT-}$	OUTA low	Output A asserted
$INB- > V_{IT+}$	OUTB low	Output B asserted
$INB- < V_{IT-}$	OUTB high	Output B not asserted

7.2 Functional Block Diagram

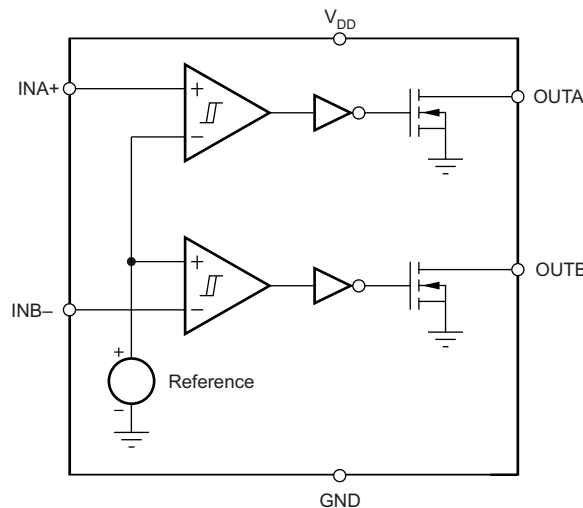

7.3 Feature Description

7.3.1 Inputs (INA+, INB-)

The TPS3700 device is a voltage detector that combines two comparators. Each comparator has one external input (inverting and noninverting); the other input is connected to the internal reference. The comparator rising threshold is designed and trimmed to be equal to the reference voltage (400 mV). Both comparators also have a built-in falling hysteresis that makes the device less sensitive to supply rail noise and ensures stable operation.

The INA+ and INB- inputs can swing from ground to 6.5 V, regardless of the device supply voltage used. Although not required in most cases, good analog design practice is to place a 1-nF to 10-nF bypass capacitor at the comparator input for extremely noisy applications to reduce sensitivity to transients and layout parasitics.

For comparator A, the corresponding output (OUTA) is driven to logic low when the input INA+ voltage drops below $(V_{IT+} - V_{hys})$. When the voltage exceeds V_{IT+} , the output (OUTA) goes to a high-impedance state; see Figure 1.

Feature Description (continued)

For comparator B, the corresponding output (OUTB) is driven to logic low when the voltage at input INB– exceeds V_{IT+} . When the voltage drops below $V_{IT+} - V_{hys}$ the output (OUTB) goes to a high-impedance state; see [Figure 1](#). Together, these comparators form a window-detection function as discussed in the [Window Voltage Detector](#) section.

7.3.2 Outputs (OUTA, OUTB)

In a typical TPS3700 application, the outputs are connected to a reset or enable input of the processor (such as a digital signal processor [DSP], central processing unit [CPU], field-programmable gate array [FPGA], or application-specific integrated circuit [ASIC]) or the outputs are connected to the enable input of a voltage regulator (such as a DC-DC or low-dropout regulator [LDO]).

The TPS3700 device provides two open-drain outputs (OUTA and OUTB). Pullup resistors must be used to hold these lines high when the output goes to high impedance (not asserted). By connecting pullup resistors to the proper voltage rails, the outputs can be connected to other devices at the correct interface-voltage levels. The TPS3700 outputs can be pulled up to 18 V, independent of the device supply voltage. By using wired-OR logic, OUTA and OUTB can merge into one logic signal that goes low if either outputs are asserted because of a fault condition.

[Table 1](#) and the [Inputs \(INA+, INB–\)](#) section describe how the outputs are asserted or deasserted. See [Figure 1](#) for a timing diagram that describes the relationship between threshold voltages and the respective output.

7.3.3 Window Voltage Detector

The inverting and noninverting configuration of the comparators forms a window-voltage detection circuit using a resistor divider network, as illustrated in [Figure 14](#) and [Figure 15](#). The input terminals can monitor any system voltage above 400 mV with the use of a resistor divider network. The INA+ and INB– terminals monitor for undervoltage and overvoltage conditions, respectively.

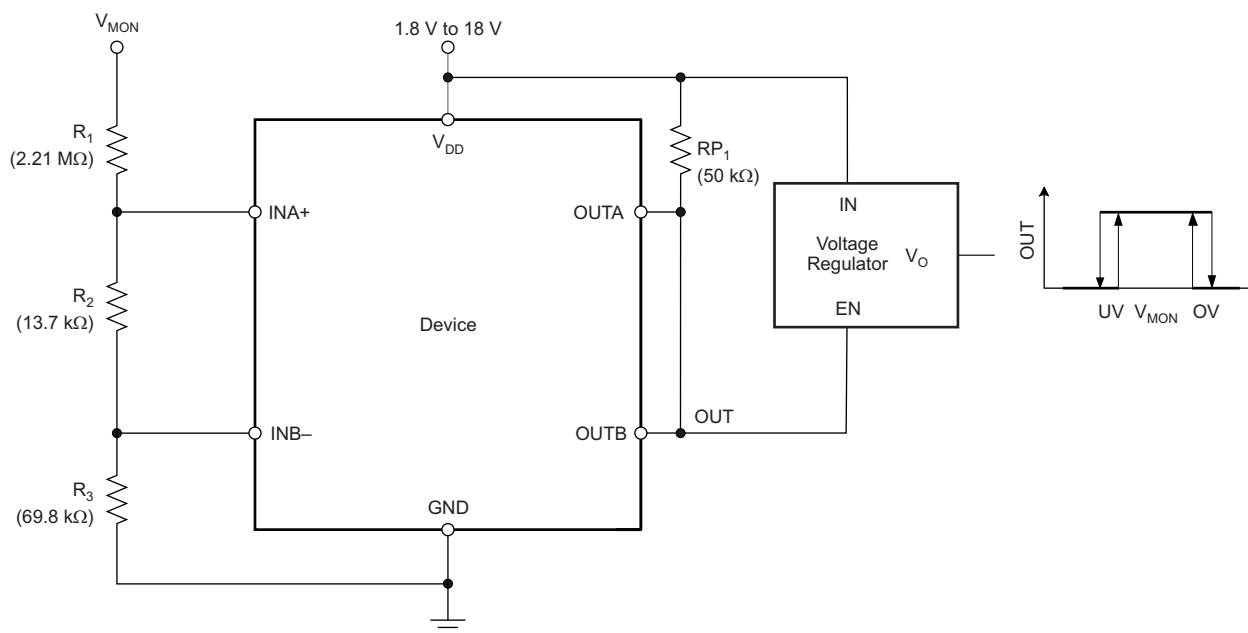

Figure 14. Window Voltage Detector Block Diagram

Feature Description (continued)

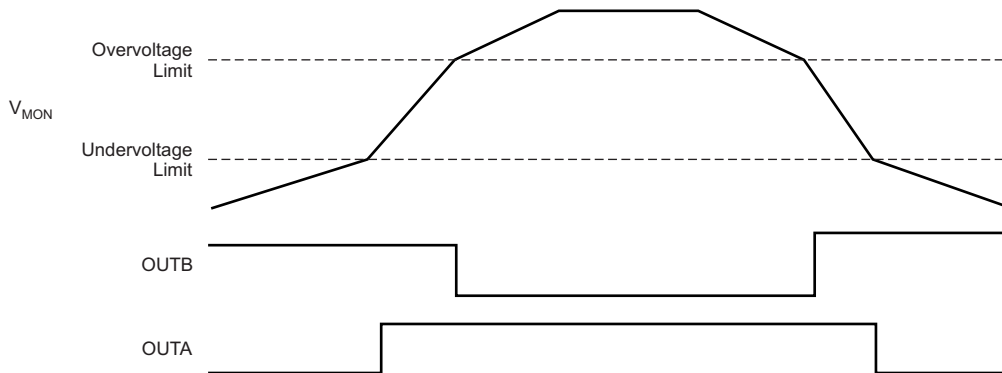

Figure 15. Window Voltage Detector Timing Diagram

7.3.4 Immunity to Input Terminal Voltage Transients

The TPS3700 device is relatively immune to short voltage transient spikes on the input terminals. Sensitivity to transients depends on both transient duration and amplitude; see the *Minimum Pulse Duration vs Threshold Overdrive Voltage* curve (Figure 7) in the *Typical Characteristics* section.

7.4 Device Functional Modes

7.4.1 Normal Operation ($V_{DD} > UVLO$)

When the voltage on V_{DD} is greater than 1.8 V for at least 150 μ s, the OUTA and OUTB signals correspond to the voltage on INA+ and INB– as listed in Table 1.

7.4.2 Undervoltage Lockout ($V_{(POR)} < V_{DD} < UVLO$)

When the voltage on V_{DD} is less than the device UVLO voltage, and greater than the power-on reset voltage, $V_{(POR)}$, the OUTA and OUTB signals are asserted and high impedance, respectively, regardless of the voltage on INA+ and INB–.

7.4.3 Power-On Reset ($V_{DD} < V_{(POR)}$)

When the voltage on V_{DD} is lower than the required voltage to internally pull the asserted output to GND ($V_{(POR)}$), both outputs are in a high-impedance state.

8 Application and Implementation

NOTE

Information in the following applications sections is not part of the TI component specification, and TI does not warrant its accuracy or completeness. TI's customers are responsible for determining suitability of components for their purposes. Customers should validate and test their design implementation to confirm system functionality.

8.1 Application Information

The TPS3700 device is a wide-supply window voltage detector that operates over a V_{DD} range of 1.8 V to 18 V. The device has two high-accuracy comparators with an internal 400-mV reference and two open-drain outputs rated to 18 V for overvoltage and undervoltage detection. The device can be used either as a window voltage detector or as two independent voltage monitors. The monitored voltages are set with the use of external resistors.

8.1.1 V_{PULLUP} to a Voltage Other Than V_{DD}

The outputs are often tied to V_{DD} through a resistor. However, some applications may require the outputs to be pulled up to a higher or lower voltage than V_{DD} to correctly interface with the reset and enable terminals of other devices.

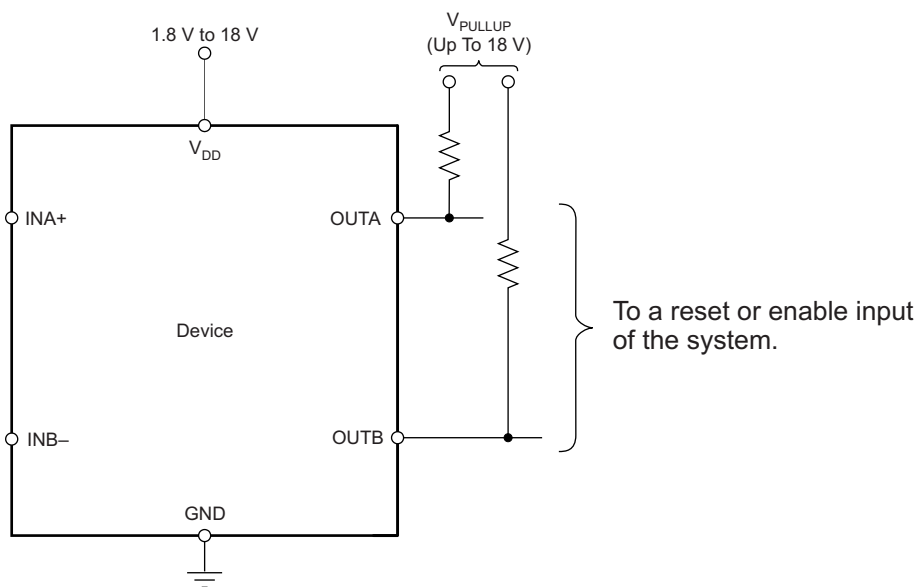

Figure 16. Interfacing to Voltages Other Than V_{DD}

Application Information (continued)

8.1.2 Monitoring V_{DD}

Many applications monitor the same rail that is powering V_{DD} . In these applications the resistor divider is simply connected to the V_{DD} rail.

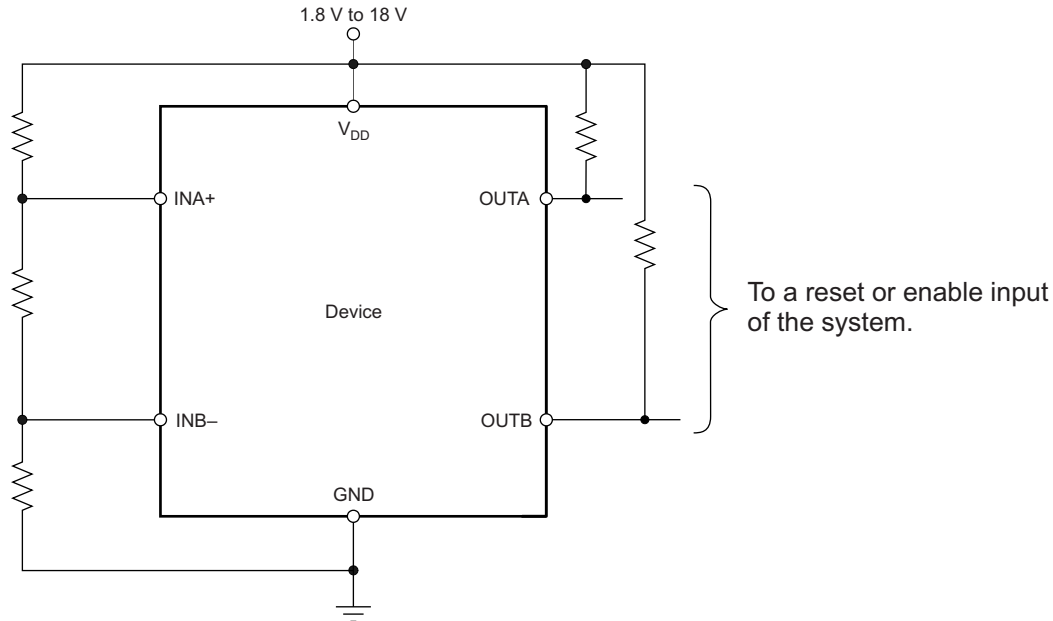
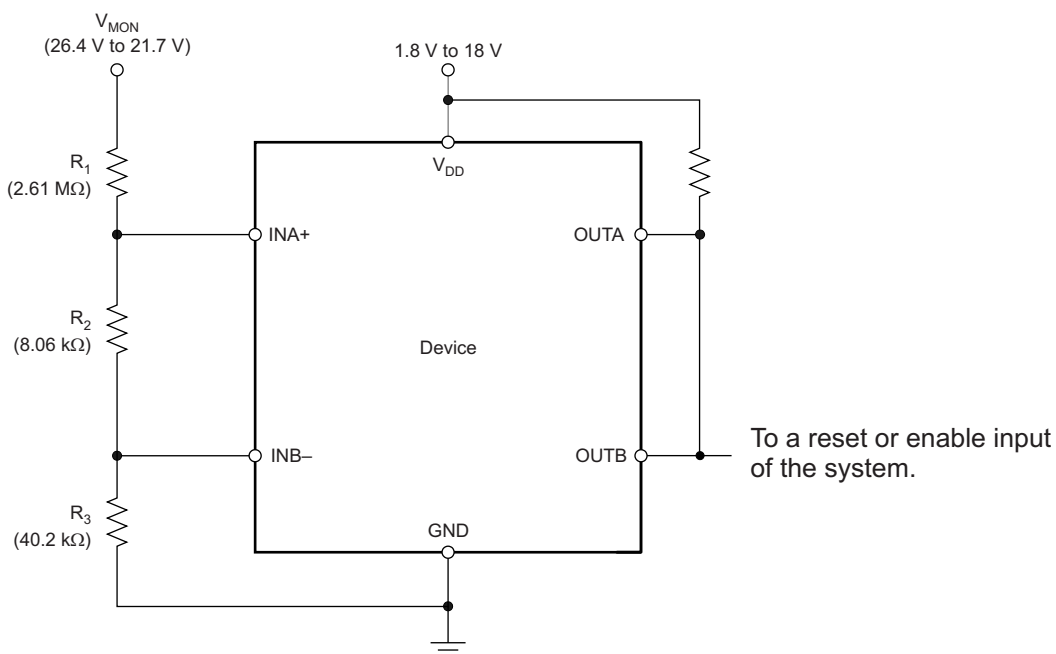

Figure 17. Monitoring the Same Voltage as V_{DD}

8.1.3 Monitoring a Voltage Other Than V_{DD}

Some applications monitor rails other than the one that is powering V_{DD} . In these types of applications the resistor divider used to set the desired thresholds is connected to the rail that is being monitored.



NOTE: The inputs can monitor a voltage higher than V_{DDmax} with the use of an external resistor divider network.

Figure 18. Monitoring a Voltage Other Than V_{DD}

Application Information (continued)

8.1.4 Monitoring Overvoltage and Undervoltage for Separate Rails

Some applications may want to monitor for overvoltage conditions on one rail while also monitoring for undervoltage conditions on a different rail. In these applications two independent resistor dividers must be used.

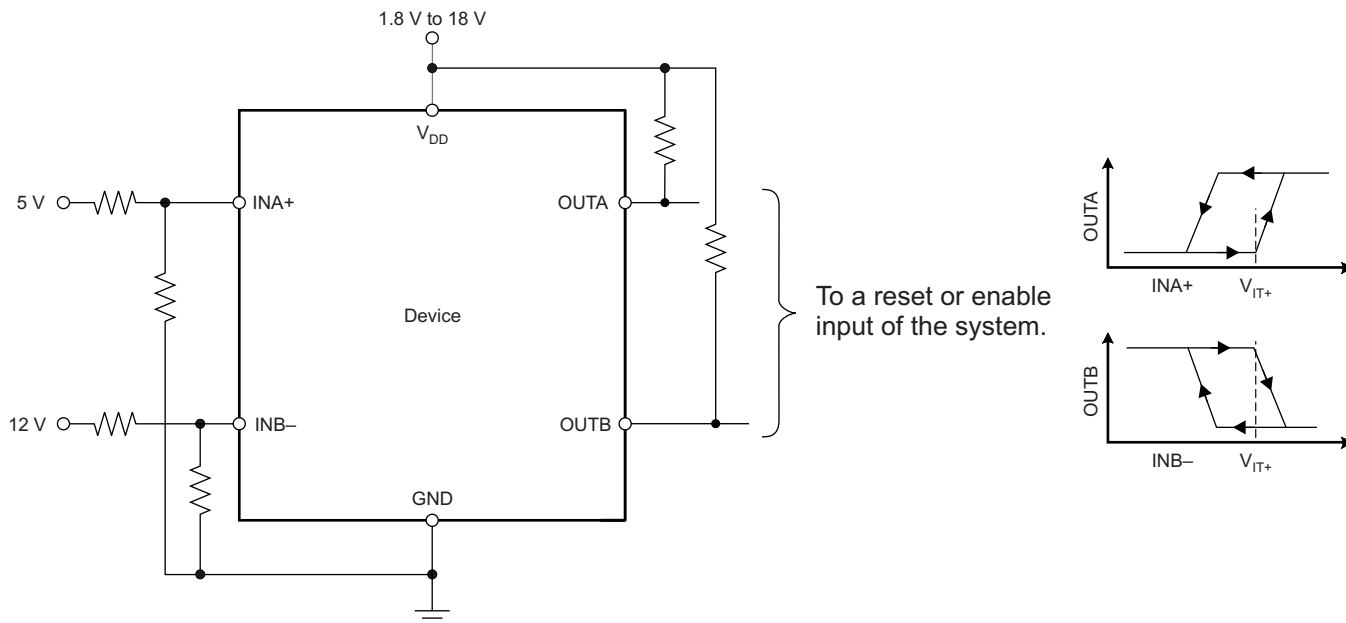

NOTE: In this case, OUTA is driven low when an undervoltage condition is detected at the 5-V rail and OUTB is driven low when an overvoltage condition is detected at the 12-V rail.

Figure 19. Monitoring Overvoltage for One Rail and Undervoltage for a Different Rail

8.2 Typical Application

The TPS3700 device is a wide-supply window voltage detector that operates over a V_{DD} range of 1.8 to 18 V. The monitored voltages are set with the use of external resistors, so the device can be used either as a window voltage detector or as two independent overvoltage and undervoltage monitors.

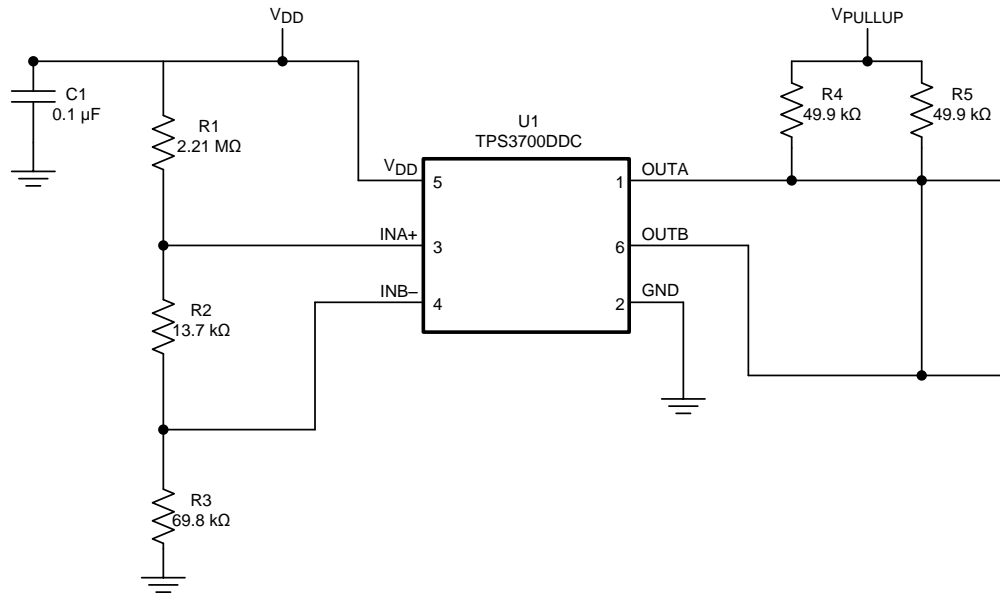

Figure 20. Typical Application Schematic

8.2.1 Design Requirements

For this design example, use the values summarized in [Table 2](#) as the input parameters.

Table 2. Design Parameters

PARAMETER	DESIGN REQUIREMENT	DESIGN RESULT
Monitored voltage	12-V nominal rail with maximum rising and falling thresholds of $\pm 10\%$	$V_{MON(UV)} = 10.99 \text{ V (8.33\%)} \pm 2.94\%$, $V_{MON(OV)} = 13.14 \text{ V (8.33\%)} \pm 2.94\%$

8.2.2 Detailed Design Procedure

8.2.2.1 Resistor Divider Selection

Use [Equation 1](#) through [Equation 4](#) to calculate the resistor divider values and target threshold voltages.

$$R_T = R_1 + R_2 + R_3 \tag{1}$$

Select a value for R_T such that the current through the divider is approximately 100 times higher than the input current at the INA+ and INB- terminals. The resistors can have high values to minimize current consumption as a result of low-input bias current without adding significant error to the resistive divider. See the application note [Optimizing Resistor Dividers at a Comparator Input \(SLVA450\)](#) for details on sizing input resistors.

Use [Equation 2](#) to calculate the value of R_3 .

$$R_3 = \frac{R_T}{V_{MON(OV)}} \times V_{IT+}$$

where:

$$V_{MON(OV)} \text{ is the target voltage at which an overvoltage condition is detected} \tag{2}$$

Use Equation 3 or Equation 4 to calculate the value of R_2 .

$$R_2 = \left[\frac{R_T}{V_{\text{MON(no UV)}}} \times V_{\text{IT+}} \right] - R_3$$

where:

$V_{\text{MON(no UV)}}$ is the target voltage at which an undervoltage condition is removed as V_{MON} rises (3)

$$R_2 = \left[\frac{R_T}{V_{\text{MON(UV)}}} \times (V_{\text{IT+}} - V_{\text{hys}}) \right] - R_3$$

where:

$V_{\text{MON(UV)}}$ is the target voltage at which an undervoltage condition is detected (4)

The worst-case tolerance can be calculated by referring to Equation 13 in application report [SLVA450, Optimizing Resistor Dividers at a Comparator Input](#) (available for download at www.ti.com). An example of the rising threshold error, $V_{\text{MON(OV)}}$, is given in Equation 5.

$$\% \text{ ACC} = \% \text{ TOL}(V_{\text{IT+(INB)}}) + 2 \times \left[1 - \frac{V_{\text{IT+(INB)}}}{V_{\text{MON(OV)}}} \right] \times \% \text{ TOL}_R = 1\% + 2 \times \left[1 - \frac{0.4}{13.2} \right] \times 1\% = 2.94\% \quad (5)$$

8.2.2.2 Pullup Resistor Selection

To ensure proper voltage levels, the pullup resistor value is selected by ensuring that the pullup voltage divided by the resistor does not exceed the sink-current capability of the device. This confirmation is calculated by verifying that the pullup voltage minus the output-leakage current ($I_{\text{kg(OD)}}$) multiplied by the resistor is greater than the desired logic-high voltage. These values are specified in the [Electrical Characteristics](#) table.

Use Equation 6 to calculate the value of the pullup resistor.

$$\frac{(V_{\text{HI}} - V_{\text{PU}})}{I_{\text{kg(OD)}}} \geq R_{\text{PU}} \geq \frac{V_{\text{PU}}}{I_{\text{O}}} \quad (6)$$

8.2.2.3 Input Supply Capacitor

Although an input capacitor is not required for stability, connecting a 0.1- μF low equivalent series resistance (ESR) capacitor across the V_{DD} terminal and GND terminal is good analog design practice. A higher-value capacitor may be necessary if large, fast rise-time load transients are anticipated, or if the device is not located close to the power source.

8.2.2.4 Input Capacitors

Although not required in most cases, for extremely noisy applications, placing a 1-nF to 10-nF bypass capacitor from the comparator inputs (INA+, INB-) to the GND terminal is good analog design practice. This capacitor placement reduces device sensitivity to transients.

8.2.3 Application Curves

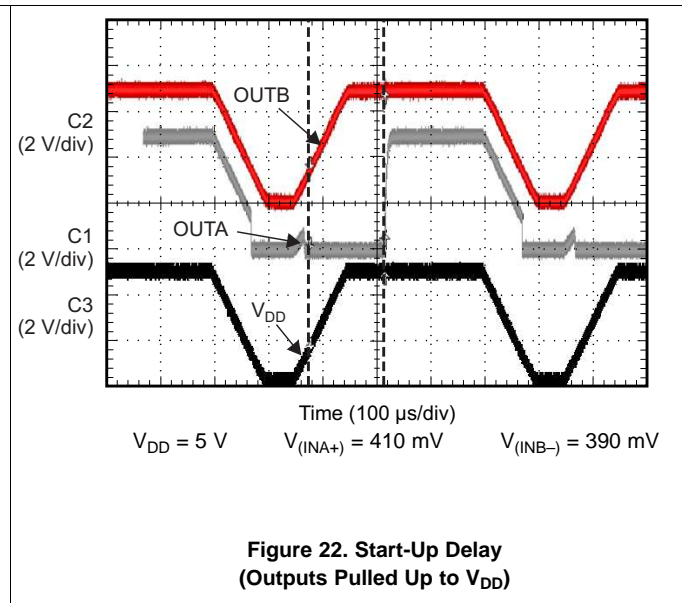
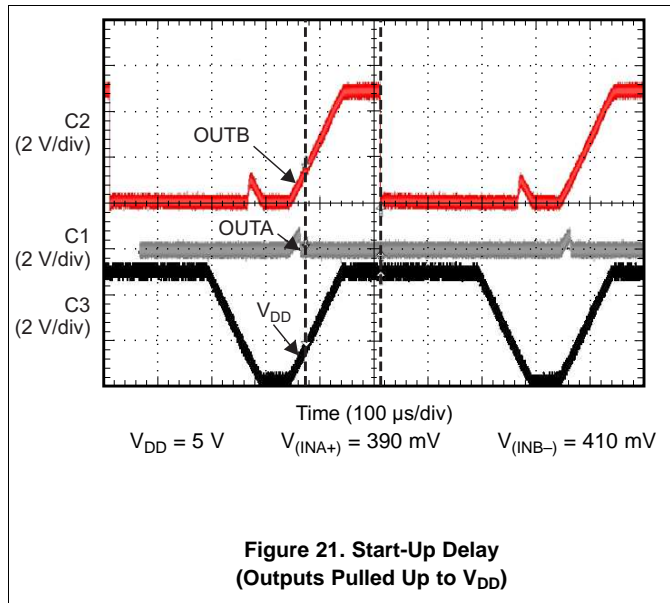
 At $T_J = 25^\circ\text{C}$

8.3 Do's and Don'ts

It is good analog design practice to have a 0.1- μF decoupling capacitor from V_{DD} to GND.

If the monitored rail is noisy, connect decoupling capacitors from the comparator inputs to GND.

Do not use resistors for the voltage divider that cause the current through them to be less than 100 times the input current of the comparators without also accounting for the effect to the accuracy.

Do not use pullup resistors that are too small, because the larger current sunk by the output then exceeds the desired low-level output voltage (V_{OL}).

9 Power-Supply Recommendations

These devices are designed to operate from an input voltage supply range between 1.8 V and 18 V.

10 Layout

10.1 Layout Guidelines

Placing a 0.1- μ F capacitor close to the V_{DD} terminal to reduce the input impedance to the device is good analog design practice. The pullup resistors can be separated if separate logic functions are needed (as shown in [Figure 23](#)) or both resistors can be tied to a single pullup resistor if a logical AND function is desired.

10.2 Layout Example

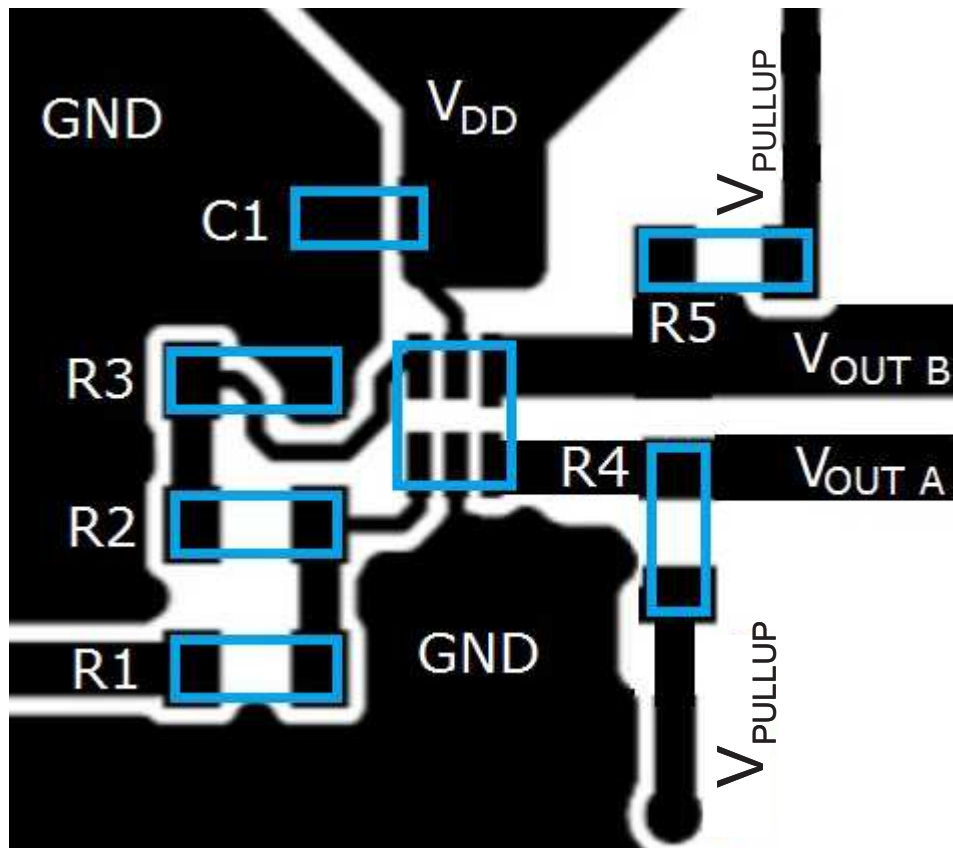

Figure 23. TPS3700 Layout Schematic

11 Device and Documentation Support

11.1 Device Support

11.1.1 Development Support

11.1.1.1 Evaluation Modules

Two evaluation modules (EVMs) are available to assist in the initial circuit performance evaluation using the TPS3700. The [TPS3700EVM-114 evaluation module](#) and the [TPS3700EVM-202 evaluation module](#) (and the related user's guides) can be requested at the Texas Instruments website through the [TPS3700 product folder](#) or purchased directly from [the TI eStore](#).

11.1.2 Device Nomenclature

Table 3. Device Nomenclature

PRODUCT	DESCRIPTION
TPS3700yyyz	yyy is package designator z is package quantity

11.2 Documentation Support

11.2.1 Related Documentation

For related documentation, see the following:

- [Using the TPS3700 as a negative rail over- and undervoltage detector](#)
- [Optimizing resistor dividers at a comparator input](#)
- [TPS3700EVM-114 Evaluation module user guide](#)
- [TPS3700EVM-202 Evaluation module user guide](#)

11.3 Receiving Notification of Documentation Updates

To receive notification of documentation updates, navigate to the device product folder on ti.com. In the upper right corner, click on *Alert me* to register and receive a weekly digest of any product information that has changed. For change details, review the revision history included in any revised document.

11.4 Community Resources

The following links connect to TI community resources. Linked contents are provided "AS IS" by the respective contributors. They do not constitute TI specifications and do not necessarily reflect TI's views; see TI's [Terms of Use](#).

TI E2E™ Online Community *TI's Engineer-to-Engineer (E2E) Community*. Created to foster collaboration among engineers. At e2e.ti.com, you can ask questions, share knowledge, explore ideas and help solve problems with fellow engineers.

Design Support *TI's Design Support* Quickly find helpful E2E forums along with design support tools and contact information for technical support.

11.5 Trademarks

E2E is a trademark of Texas Instruments.
All other trademarks are the property of their respective owners.

11.6 Electrostatic Discharge Caution



This integrated circuit can be damaged by ESD. Texas Instruments recommends that all integrated circuits be handled with appropriate precautions. Failure to observe proper handling and installation procedures can cause damage.

ESD damage can range from subtle performance degradation to complete device failure. Precision integrated circuits may be more susceptible to damage because very small parametric changes could cause the device not to meet its published specifications.

11.7 Glossary

SLYZ022 — *TI Glossary.*

This glossary lists and explains terms, acronyms, and definitions.

12 Mechanical, Packaging, and Orderable Information

The following pages include mechanical, packaging, and orderable information. This information is the most current data available for the designated devices. This data is subject to change without notice and revision of this document. For browser-based versions of this data sheet, refer to the left-hand navigation.

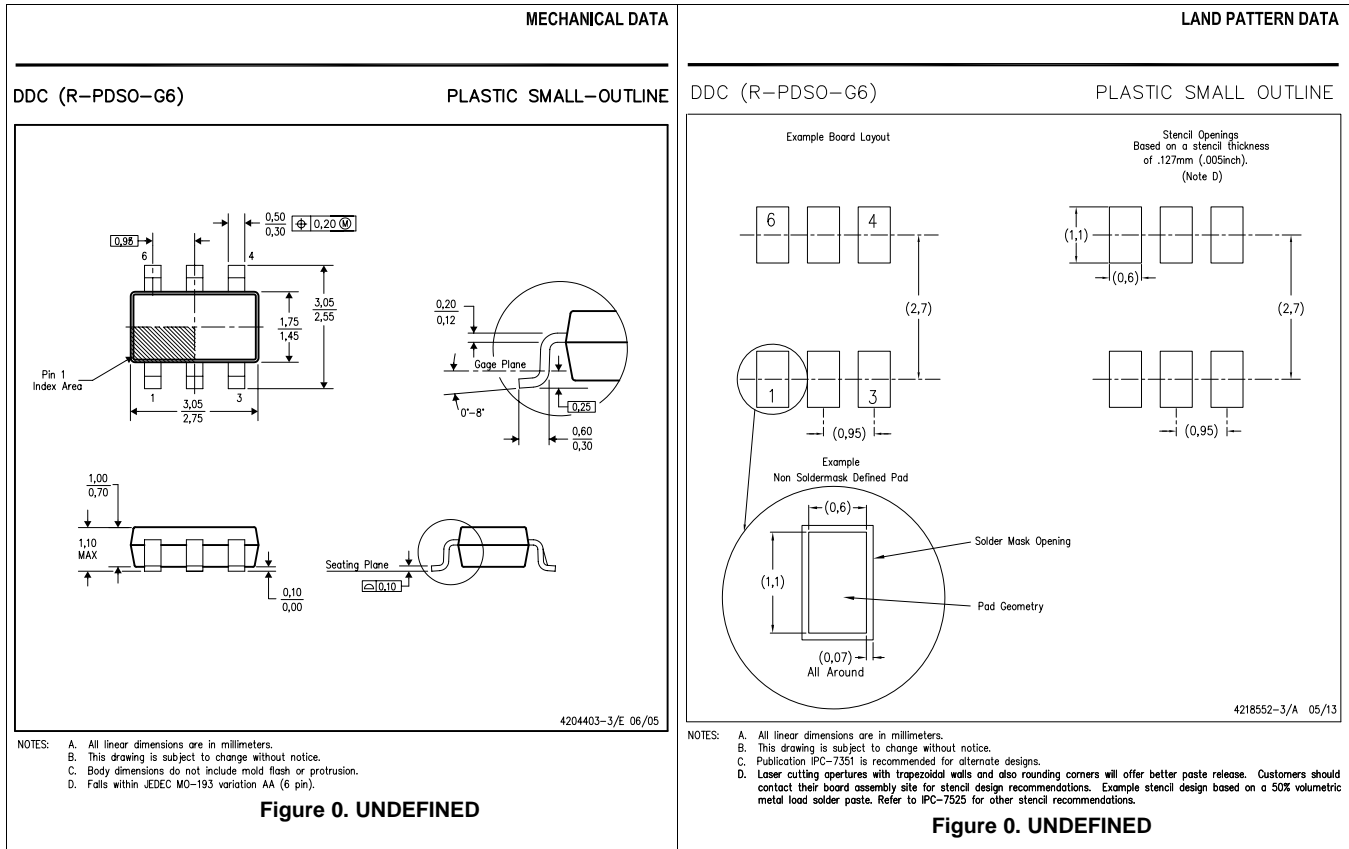

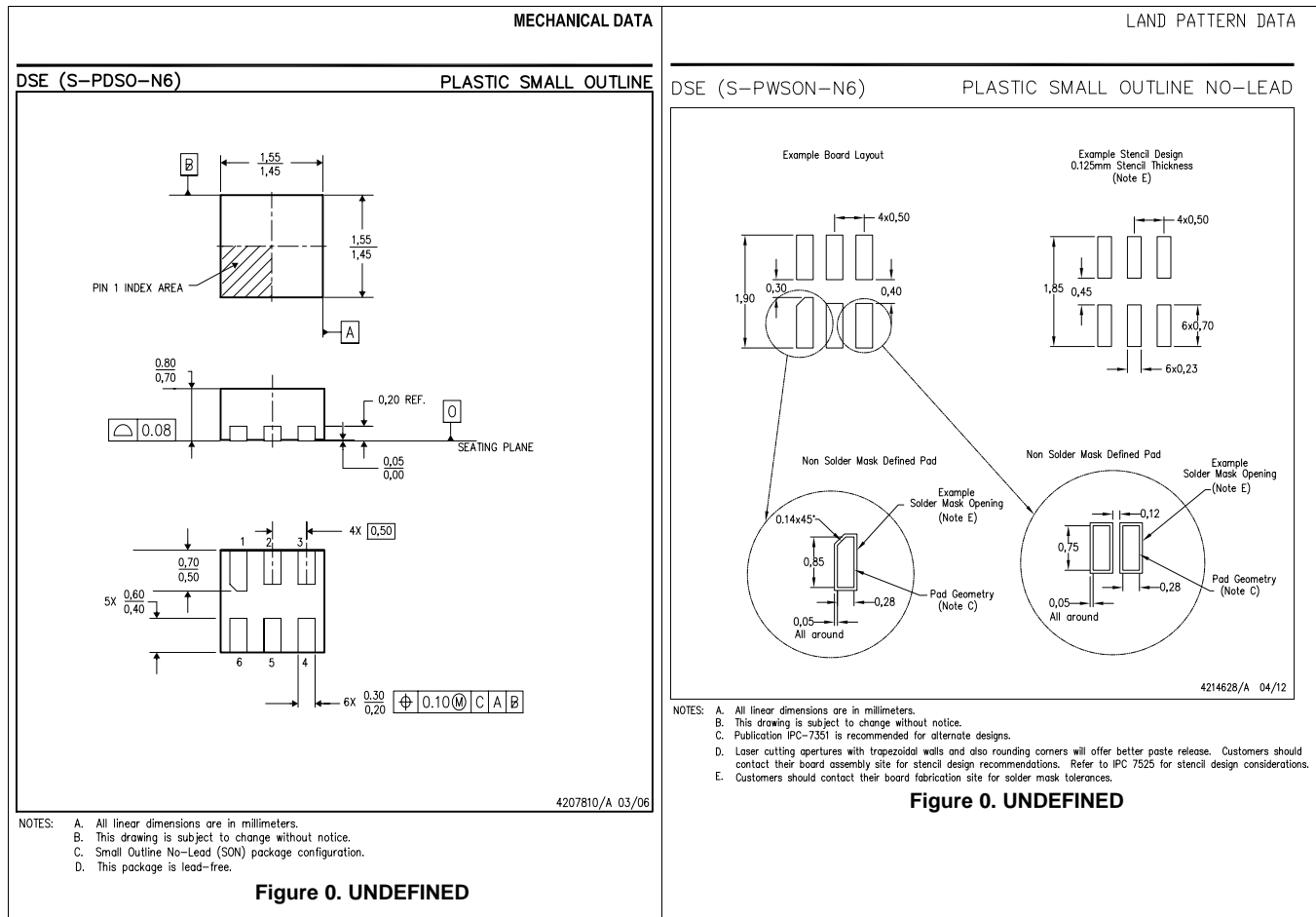

PACKAGING INFORMATION

Orderable part number	Status (1)	Material type (2)	Package Pins	Package qty Carrier	RoHS (3)	Lead finish/ Ball material (4)	MSL rating/ Peak reflow (5)	Op temp (°C)	Part marking (6)
TPS3700DDCR	Active	Production	SOT-23-THIN (DDC) 6	3000 LARGE T&R	Yes	NIPDAU SN	Level-2-260C-1 YEAR	-40 to 125	PXVQ
TPS3700DDCR.A	Active	Production	SOT-23-THIN (DDC) 6	3000 LARGE T&R	Yes	NIPDAU	Level-2-260C-1 YEAR	-40 to 125	PXVQ
TPS3700DDCR2	Active	Production	SOT-23-THIN (DDC) 6	3000 LARGE T&R	Yes	NIPDAU	Level-2-260C-1 YEAR	-40 to 125	PB4Q
TPS3700DDCR2.A	Active	Production	SOT-23-THIN (DDC) 6	3000 LARGE T&R	Yes	NIPDAU	Level-2-260C-1 YEAR	-40 to 125	PB4Q
TPS3700DDCR2G4	Active	Production	SOT-23-THIN (DDC) 6	3000 LARGE T&R	Yes	NIPDAU	Level-2-260C-1 YEAR	-40 to 125	PB4Q
TPS3700DDCR2G4.A	Active	Production	SOT-23-THIN (DDC) 6	3000 LARGE T&R	Yes	NIPDAU	Level-2-260C-1 YEAR	-40 to 125	PB4Q
TPS3700DDCRG4	Active	Production	SOT-23-THIN (DDC) 6	3000 LARGE T&R	Yes	NIPDAU	Level-2-260C-1 YEAR	-40 to 125	PXVQ
TPS3700DDCRG4.A	Active	Production	SOT-23-THIN (DDC) 6	3000 LARGE T&R	Yes	NIPDAU	Level-2-260C-1 YEAR	-40 to 125	PXVQ
TPS3700DDCT	Active	Production	SOT-23-THIN (DDC) 6	250 SMALL T&R	Yes	NIPDAU SN	Level-2-260C-1 YEAR	-40 to 125	PXVQ
TPS3700DDCT.A	Active	Production	SOT-23-THIN (DDC) 6	250 SMALL T&R	Yes	NIPDAU	Level-2-260C-1 YEAR	-40 to 125	PXVQ
TPS3700DSER	Active	Production	WSON (DSE) 6	3000 LARGE T&R	Yes	NIPDAU	Level-1-260C-UNLIM	-40 to 125	(7I, BE)
TPS3700DSER.A	Active	Production	WSON (DSE) 6	3000 LARGE T&R	Yes	NIPDAU	Level-1-260C-UNLIM	-40 to 125	(7I, BE)
TPS3700DSET	Active	Production	WSON (DSE) 6	250 SMALL T&R	Yes	NIPDAU	Level-1-260C-UNLIM	-40 to 125	(7I, BE)
TPS3700DSET.A	Active	Production	WSON (DSE) 6	250 SMALL T&R	Yes	NIPDAU	Level-1-260C-UNLIM	-40 to 125	(7I, BE)
TPS3700DSETG4	Active	Production	WSON (DSE) 6	250 SMALL T&R	Yes	NIPDAU	Level-1-260C-UNLIM	-40 to 125	7I
TPS3700DSETG4.A	Active	Production	WSON (DSE) 6	250 SMALL T&R	Yes	NIPDAU	Level-1-260C-UNLIM	-40 to 125	7I

(1) **Status:** For more details on status, see our [product life cycle](#).

(2) **Material type:** When designated, preproduction parts are prototypes/experimental devices, and are not yet approved or released for full production. Testing and final process, including without limitation quality assurance, reliability performance testing, and/or process qualification, may not yet be complete, and this item is subject to further changes or possible discontinuation. If available for ordering, purchases will be subject to an additional waiver at checkout, and are intended for early internal evaluation purposes only. These items are sold without warranties of any kind.

(3) **RoHS values:** Yes, No, RoHS Exempt. See the [TI RoHS Statement](#) for additional information and value definition.

(4) **Lead finish/Ball material:** Parts may have multiple material finish options. Finish options are separated by a vertical ruled line. Lead finish/Ball material values may wrap to two lines if the finish value exceeds the maximum column width.

(5) **MSL rating/Peak reflow:** The moisture sensitivity level ratings and peak solder (reflow) temperatures. In the event that a part has multiple moisture sensitivity ratings, only the lowest level per JEDEC standards is shown. Refer to the shipping label for the actual reflow temperature that will be used to mount the part to the printed circuit board.

(6) **Part marking:** There may be an additional marking, which relates to the logo, the lot trace code information, or the environmental category of the part.

Multiple part markings will be inside parentheses. Only one part marking contained in parentheses and separated by a "~" will appear on a part. If a line is indented then it is a continuation of the previous line and the two combined represent the entire part marking for that device.

Important Information and Disclaimer: The information provided on this page represents TI's knowledge and belief as of the date that it is provided. TI bases its knowledge and belief on information provided by third parties, and makes no representation or warranty as to the accuracy of such information. Efforts are underway to better integrate information from third parties. TI has taken and continues to take reasonable steps to provide representative and accurate information but may not have conducted destructive testing or chemical analysis on incoming materials and chemicals. TI and TI suppliers consider certain information to be proprietary, and thus CAS numbers and other limited information may not be available for release.

In no event shall TI's liability arising out of such information exceed the total purchase price of the TI part(s) at issue in this document sold by TI to Customer on an annual basis.

OTHER QUALIFIED VERSIONS OF TPS3700 :

- Automotive : [TPS3700-Q1](#)

NOTE: Qualified Version Definitions:

- Automotive - Q100 devices qualified for high-reliability automotive applications targeting zero defects

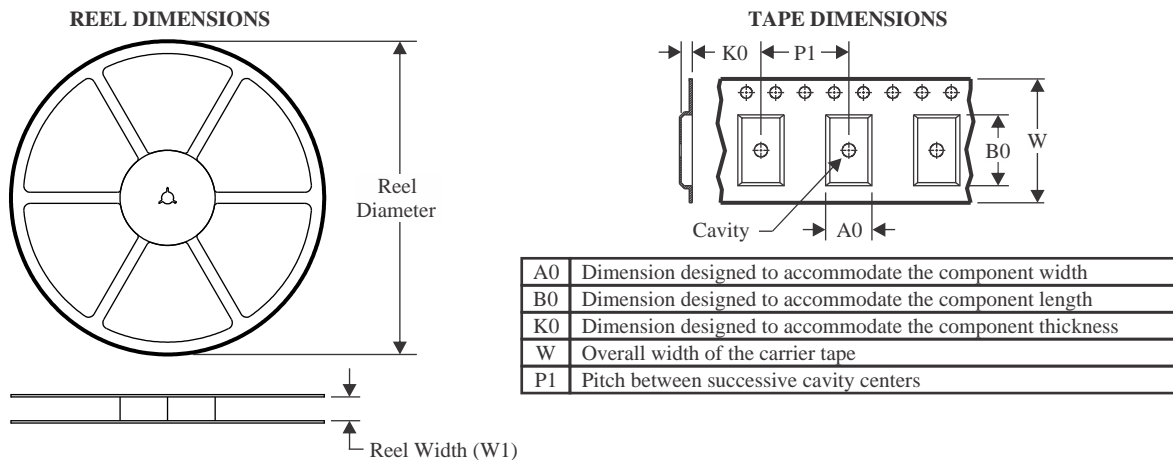
TAPE AND REEL INFORMATION

QUADRANT ASSIGNMENTS FOR PIN 1 ORIENTATION IN TAPE

*All dimensions are nominal

Device	Package Type	Package Drawing	Pins	SPQ	Reel Diameter (mm)	Reel Width W1 (mm)	A0 (mm)	B0 (mm)	K0 (mm)	P1 (mm)	W (mm)	Pin1 Quadrant
TPS3700DDCR	SOT-23-THIN	DDC	6	3000	180.0	8.4	3.2	3.2	1.4	4.0	8.0	Q3
TPS3700DDCR	SOT-23-THIN	DDC	6	3000	179.0	8.4	3.2	3.2	1.4	4.0	8.0	Q3
TPS3700DDCR2	SOT-23-THIN	DDC	6	3000	179.0	8.4	3.2	3.2	1.4	4.0	8.0	Q2
TPS3700DDCR2G4	SOT-23-THIN	DDC	6	3000	179.0	8.4	3.2	3.2	1.4	4.0	8.0	Q2
TPS3700DDCRG4	SOT-23-THIN	DDC	6	3000	179.0	8.4	3.2	3.2	1.4	4.0	8.0	Q3
TPS3700DDCT	SOT-23-THIN	DDC	6	250	180.0	8.4	3.2	3.2	1.4	4.0	8.0	Q3
TPS3700DDCT	SOT-23-THIN	DDC	6	250	179.0	8.4	3.2	3.2	1.4	4.0	8.0	Q3
TPS3700DSER	WSON	DSE	6	3000	178.0	8.4	1.7	1.7	0.95	4.0	8.0	Q2
TPS3700DSET	WSON	DSE	6	250	178.0	8.4	1.7	1.7	0.95	4.0	8.0	Q2
TPS3700DSETG4	WSON	DSE	6	250	178.0	8.4	1.7	1.7	0.95	4.0	8.0	Q2

TAPE AND REEL BOX DIMENSIONS

*All dimensions are nominal

Device	Package Type	Package Drawing	Pins	SPQ	Length (mm)	Width (mm)	Height (mm)
TPS3700DDCR	SOT-23-THIN	DDC	6	3000	210.0	185.0	35.0
TPS3700DDCR	SOT-23-THIN	DDC	6	3000	213.0	191.0	35.0
TPS3700DDCR2	SOT-23-THIN	DDC	6	3000	213.0	191.0	35.0
TPS3700DDCR2G4	SOT-23-THIN	DDC	6	3000	213.0	191.0	35.0
TPS3700DDCRG4	SOT-23-THIN	DDC	6	3000	213.0	191.0	35.0
TPS3700DDCT	SOT-23-THIN	DDC	6	250	210.0	185.0	35.0
TPS3700DDCT	SOT-23-THIN	DDC	6	250	213.0	191.0	35.0
TPS3700DSER	WSON	DSE	6	3000	205.0	200.0	33.0
TPS3700DSET	WSON	DSE	6	250	205.0	200.0	33.0
TPS3700DSETG4	WSON	DSE	6	250	205.0	200.0	33.0

IMPORTANT NOTICE AND DISCLAIMER

TI PROVIDES TECHNICAL AND RELIABILITY DATA (INCLUDING DATASHEETS), DESIGN RESOURCES (INCLUDING REFERENCE DESIGNS), APPLICATION OR OTHER DESIGN ADVICE, WEB TOOLS, SAFETY INFORMATION, AND OTHER RESOURCES "AS IS" AND WITH ALL FAULTS, AND DISCLAIMS ALL WARRANTIES, EXPRESS AND IMPLIED, INCLUDING WITHOUT LIMITATION ANY IMPLIED WARRANTIES OF MERCHANTABILITY, FITNESS FOR A PARTICULAR PURPOSE OR NON-INFRINGEMENT OF THIRD PARTY INTELLECTUAL PROPERTY RIGHTS.

These resources are intended for skilled developers designing with TI products. You are solely responsible for (1) selecting the appropriate TI products for your application, (2) designing, validating and testing your application, and (3) ensuring your application meets applicable standards, and any other safety, security, regulatory or other requirements.

These resources are subject to change without notice. TI grants you permission to use these resources only for development of an application that uses the TI products described in the resource. Other reproduction and display of these resources is prohibited. No license is granted to any other TI intellectual property right or to any third party intellectual property right. TI disclaims responsibility for, and you fully indemnify TI and its representatives against any claims, damages, costs, losses, and liabilities arising out of your use of these resources.

TI's products are provided subject to [TI's Terms of Sale](#), [TI's General Quality Guidelines](#), or other applicable terms available either on ti.com or provided in conjunction with such TI products. TI's provision of these resources does not expand or otherwise alter TI's applicable warranties or warranty disclaimers for TI products. Unless TI explicitly designates a product as custom or customer-specified, TI products are standard, catalog, general purpose devices.

TI objects to and rejects any additional or different terms you may propose.

Copyright © 2026, Texas Instruments Incorporated

Last updated 10/2025