

TPS92613-Q1 Automotive Single-Channel LED Driver

1 Features

- AEC-Q100-qualified for automotive applications:
 - Temperature grade 1: -40°C to $+125^{\circ}\text{C}$, T_A
- Functional safety capable
 - Documentation available to aid functional safety system design
- Wide input voltage range: 4.5 V to 40 V
- Low quiescent and low fault-mode current: typical 200 μA
- Single high-precision current regulation:
 - $\pm 4.6\%$ Accuracy over full junction temperature range
 - Constant current adjustable by external sense resistor
 - Up to 600 mA maximum current
 - Brightness control by input PWM duty cycle
- Heat sharing with external resistor
- Low dropout voltage (sense-resistor voltage drop included):
 - Maximum dropout: 150 mV at 10 mA
 - Maximum dropout: 400 mV at 70 mA
 - Maximum dropout: 700 mV at 150 mA
 - Maximum dropout: 1.3 V at 300 mA
- Diagnostics and protection:
 - LED open-circuit and short-circuit detection with auto-recovery
 - Diagnostic enable with adjustable threshold for low-dropout operation
 - Fault bus up to 15 devices, configurable as either one-fails-all-fail or only-failed-channel-off (N-1)
 - Thermal shutdown
- Operating junction temperature range: -40°C to $+150^{\circ}\text{C}$

2 Applications

- Interior lighting: dome light, reading lamp
- Exterior lighting - small light: door handle, blind-spot detection indicator, charging inlet
- Exterior lighting - rear light: rear lamp, center high-mounted stop lamp, side marker
- General-purpose LED driver applications

3 Description

With LEDs being widely used in automotive applications, simple LED drivers are more and more popular. Comparing to discrete solutions, a low-cost monolithic solution lowers system-level component count and significantly improves current accuracy and reliability.

The TPS92613-Q1 device is a single-channel, high-side LED driver operating from an automotive car battery. It is a simple, yet elegant, solution to deliver constant current for a single LED string with full LED diagnostics. The one-fails-all-fail feature is able to work together with other LED drivers, such as the TPS9261x-Q1, TPS9263x-Q1, and TPS92830-Q1 devices, to address different requirements.

Device Information⁽¹⁾

PART NUMBER	PACKAGE	BODY SIZE (NOM)
TPS92613-Q1	TO-263 (7)	10.16 mm x 9.85 mm

(1) For all available packages, see the orderable addendum at the end of the data sheet.

Typical Application Diagram

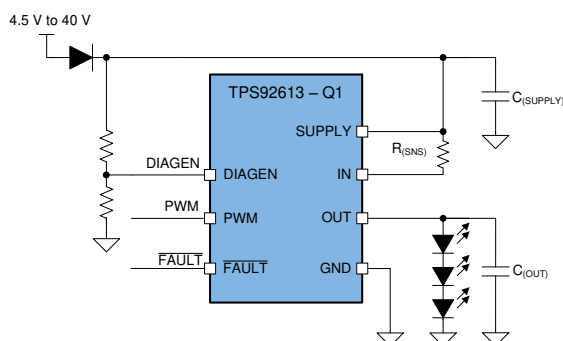

Table of Contents

1 Features	1	7.4 Device Functional Modes.....	15
2 Applications	1	8 Application and Implementation	16
3 Description	1	8.1 Application Information.....	16
4 Revision History	2	8.2 Typical Applications	16
5 Pin Configuration and Functions	3	9 Power Supply Recommendations	23
6 Specifications	4	10 Layout	23
6.1 Absolute Maximum Ratings	4	10.1 Layout Guidelines	23
6.2 ESD Ratings.....	4	10.2 Layout Example	23
6.3 Recommended Operating Conditions.....	4	11 Device and Documentation Support	24
6.4 Thermal Information	4	11.1 Documentation Support	24
6.5 Electrical Characteristics.....	4	11.2 Receiving Notification of Documentation Updates	24
6.6 Timing Requirements	5	11.3 Support Resources	24
6.7 Typical Characteristics	7	11.4 Trademarks	24
7 Detailed Description	10	11.5 Electrostatic Discharge Caution.....	24
7.1 Overview	10	11.6 Glossary	24
7.2 Functional Block Diagram	10	12 Mechanical, Packaging, and Orderable	24
7.3 Feature Description.....	10	Information	24

4 Revision History

Changes from Revision A (December 2019) to Revision B	Page
• Added the functional safety capable link to the Features section	1

Changes from Original (April 2019) to Revision A	Page
• Changed data sheet status from: Advanced Information to: Production Data	1

5 Pin Configuration and Functions

**NDR Package
7-Pin TO-263 With Exposed Thermal Pad
Top View**

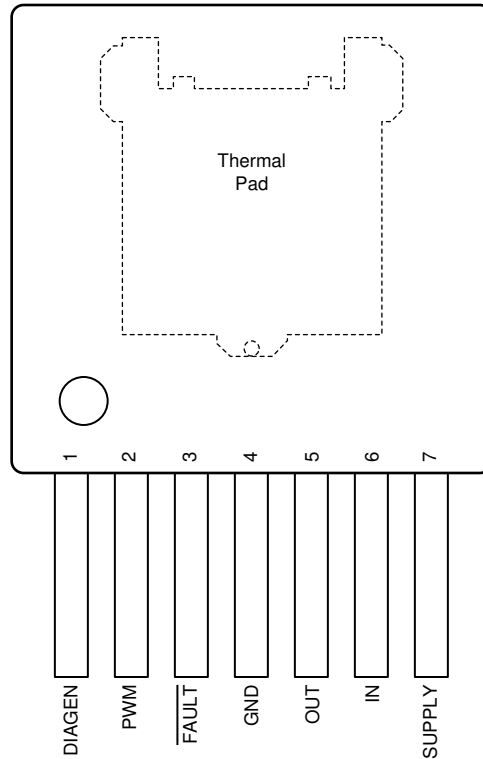

Pin Functions

PIN		I/O	DESCRIPTION
NO.	NAME		
1	DIAGEN	I	Enable pin for LED open-circuit detection to avoid false open diagnostics during low-dropout operation
2	PWM	I	PWM input for current output ON/OFF control
3	$\overline{\text{FAULT}}$	I/O	Fault output, support one-fails-all-fail fault bus
4	GND	—	Ground
5	OUT	O	Constant-current output, connect to anode of the top LED in LED-string
6	IN	I	Current input
7	SUPPLY	I	Device supply voltage
—	Thermal pad	—	Thermal pad, connect to ground

6 Specifications

6.1 Absolute Maximum Ratings

 over operating ambient temperature range (unless otherwise noted)⁽¹⁾

		MIN	MAX	UNIT
High-voltage input	DIAGEN, IN, PWM, SUPPLY	-0.3	45	V
High-voltage output	OUT	-0.3	45	V
Fault bus	FAULT	-0.3	22	V
IN to OUT	$V_{(IN)} - V_{(OUT)}$	-0.3	45	V
SUPPLY to IN	$V_{(SUPPLY)} - V_{(IN)}$	-0.3	1	V
Operating junction temperature, T_J		-40	150	°C
Storage temperature, T_{stg}		-40	150	°C

(1) Stresses beyond those listed under *Absolute Maximum Ratings* may cause permanent damage to the device. These are stress ratings only, which do not imply functional operation of the device at these or any other conditions beyond those indicated under *Recommended Operating Conditions*. Exposure to absolute-maximum-rated conditions for extended periods may affect device reliability.

6.2 ESD Ratings

			VALUE	UNIT
$V_{(ESD)}$	Electrostatic discharge	Human-body model (HBM), per AEC Q100-002 ⁽¹⁾ Device HBM ESD Classification Level H2	All pins	±2000
		Charged-device model (CDM), per AEC Q100-011 Device CDM ESD Classification Level C3B	All pins	±500
			Corner pins (1 and 7)	±750

(1) AEC Q100-002 indicates that HBM stressing shall be in accordance with the ANSI/ESDA/JEDEC JS-001 specification.

6.3 Recommended Operating Conditions

over operating ambient temperature range (unless otherwise noted)

		MIN	NOM	MAX	UNIT
SUPPLY	Device supply voltage	4.5		40	V
IN	Sense voltage	4.4		40	V
PWM	PWM inputs	0		40	V
DIAGEN	Diagnostics enable pin	0		40	V
OUT	Driver output	0		40	V
FAULT	Fault bus	0		7	V
Operating ambient temperature, T_A		-40		125	°C

6.4 Thermal Information

THERMAL METRIC ⁽¹⁾		TPS92613-Q1	UNIT
		NDR (TO-263)	
		7 PINS	
$R_{\theta JA}$	Junction-to-ambient thermal resistance	28.4	°C/W
$R_{\theta JC(top)}$	Junction-to-case (top) thermal resistance	23.1	°C/W
$R_{\theta JB}$	Junction-to-board thermal resistance	10.1	°C/W
Ψ_{JT}	Junction-to-top characterization parameter	4.2	°C/W
Ψ_{JB}	Junction-to-board characterization parameter	9.9	°C/W
$R_{\theta JC(bot)}$	Junction-to-case (bottom) thermal resistance	3.5	°C/W

(1) For more information about traditional and new thermal metrics, see the [Semiconductor and IC Package Thermal Metrics](#) application report.

6.5 Electrical Characteristics

 $V_{(SUPPLY)} = 5\text{ V to }40\text{ V}$, $T_J = -40^\circ\text{C to }+150^\circ\text{C}$ unless otherwise noted

PARAMETER		TEST CONDITIONS		MIN	TYP	MAX	UNIT
BIAS							
$V_{(POR_rising)}$	Supply voltage POR rising threshold			3.2	4		V

Electrical Characteristics (continued)

 $V_{(SUPPLY)} = 5\text{ V to }40\text{ V}$, $T_J = -40^\circ\text{C to }+150^\circ\text{C}$ unless otherwise noted

PARAMETER		TEST CONDITIONS	MIN	TYP	MAX	UNIT
$V_{(POR_falling)}$	Supply voltage POR falling threshold		2.2	3		V
$I_{(Quiescent)}$	Device standby current	PWM = HIGH	0.1	0.2	0.25	mA
$I_{(FAULT)}$	Device current in fault mode	PWM = HIGH, $\overline{\text{FAULT}}$ externally pulled LOW	0.1	0.2	0.25	mA
LOGIC INPUTS (DIAGEN, PWM)						
$V_{IL(DIAGEN)}$	Input logic-low voltage, DIAGEN		1.045	1.1	1.155	V
$V_{IH(DIAGEN)}$	Input logic-high voltage, DIAGEN		1.16	1.2	1.24	V
$V_{IL(PWM)}$	Input logic-low voltage, PWM		1.045	1.1	1.155	V
$V_{IH(PWM)}$	Input logic-high voltage, PWM		1.16	1.2	1.24	V
CONSTANT-CURRENT DRIVER						
$I_{(OUT)}$	Device output-current range	100% duty cycle	4		600	mA
$V_{(CS_REG)}$	Sense-resistor regulation voltage	$T_A = 25^\circ\text{C}$, $V_{(SUPPLY)} = 4.5\text{ V to }18\text{ V}$	94	98	102	mV
		$T_A = -40^\circ\text{C to }+125^\circ\text{C}$, $V_{(SUPPLY)} = 4.5\text{ V to }18\text{ V}$	93.5	98	102.5	
$R_{(CS_REG)}$	Sense-resistor range		0.16		50	Ω
$V_{(DROPOUT)}$	Voltage dropout from SUPPLY to OUT	$V_{(CS_REG)}$ voltage included, current setting of 10 mA		120	150	mV
		$V_{(CS_REG)}$ voltage included, current setting of 70 mA		250	400	
		$V_{(CS_REG)}$ voltage included, current setting of 150 mA		430	700	
		$V_{(CS_REG)}$ voltage included, current setting of 300 mA		800	1300	
DIAGNOSTICS						
$V_{(OPEN_th_rising)}$	LED open rising threshold, $V_{(IN)} - V_{(OUT)}$		235	290	335	mV
$V_{(OPEN_th_falling)}$	LED open falling threshold, $V_{(IN)} - V_{(OUT)}$		70	100	135	mV
$V_{(SG_th_rising)}$	Channel output $V_{(OUT)}$ short-to-ground rising threshold		1.14	1.2	1.26	V
$V_{(SG_th_falling)}$	Channel output $V_{(OUT)}$ short-to-ground falling threshold		0.82	0.865	0.91	V
$I_{(Retry)}$	Channel output $V_{(OUT)}$ short-to-ground retry current		0.64	1.08	1.528	mA
FAULT						
$V_{IL(FAULT)}$	Logic input low threshold				0.7	V
$V_{IH(FAULT)}$	Logic input high threshold		2			V
$V_{OL(FAULT)}$	Logic output low threshold	With 500- μA external pullup			0.4	V
$V_{OH(FAULT)}$	Logic output high threshold	With 1- μA external pulldown, $V_{(SUPPLY)} = 12\text{ V}$	5		7	V
$I_{(FAULT_pulldown)}$	$\overline{\text{FAULT}}$ internal pulldown current		500	750	1000	μA
$I_{(FAULT_pullup)}$	$\overline{\text{FAULT}}$ internal pullup current		5	8	12	μA
THERMAL PROTECTION						
$T_{(TSD)}$	Thermal shutdown junction temperature threshold		157	172	187	$^\circ\text{C}$
$T_{(TSD_HYS)}$	Thermal shutdown junction temperature hysteresis			15		$^\circ\text{C}$

6.6 Timing Requirements

		MIN	NOM	MAX	UNIT
$t_{(PWM_delay_rising)}$	PWM rising edge delay, 50% PWM voltage to 10% of output current closed loop, $t_2 - t_1$ as shown in Figure 1	10	17	25	μs
$t_{(PWM_delay_falling)}$	PWM falling edge delay, 50% PWM voltage to 90% of output current open loop, $t_5 - t_4$ as shown in Figure 1	15	21	30	μs
$t_{(DEVICE_STARTUP)}$	SUPPLY rising edge to 10% output current at 200-mA set current and 14 V, $t_8 - t_7$ as shown in Figure 1		100	150	μs
$t_{(OPEN_deg)}$	LED-open fault-deglitch time	80	125	175	μs
$t_{(SG_deg)}$	Output short-to-ground detection deglitch time	80	125	175	μs
$t_{(TSD_deg)}$	Thermal over temperature deglitch timer		50		μs
$t_{(Recover_deg)}$	Fault recovery deglitch timer	8.5	16	25	μs

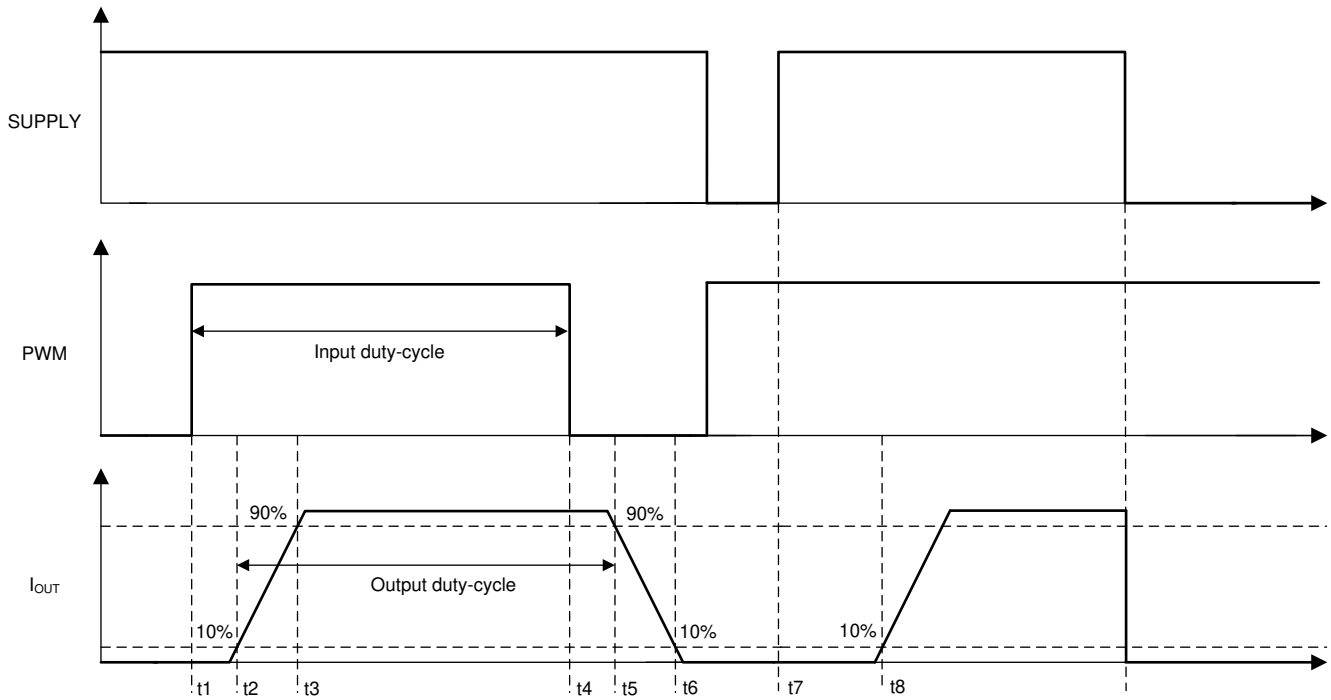
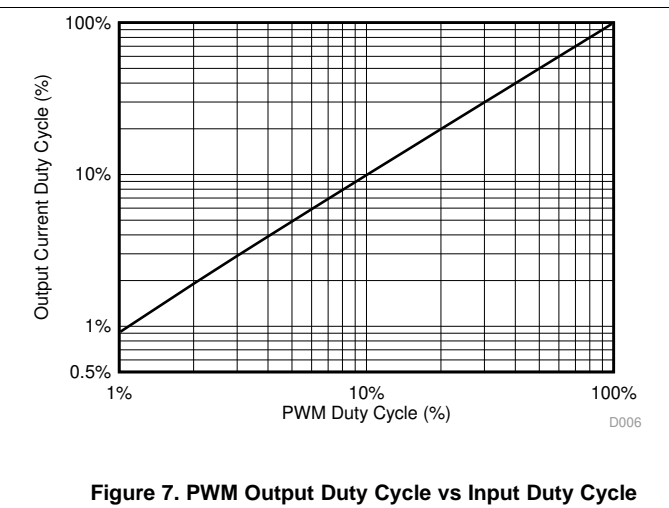
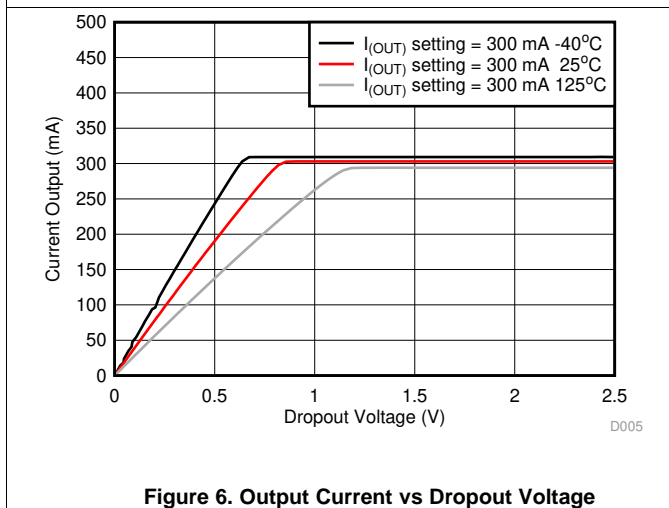
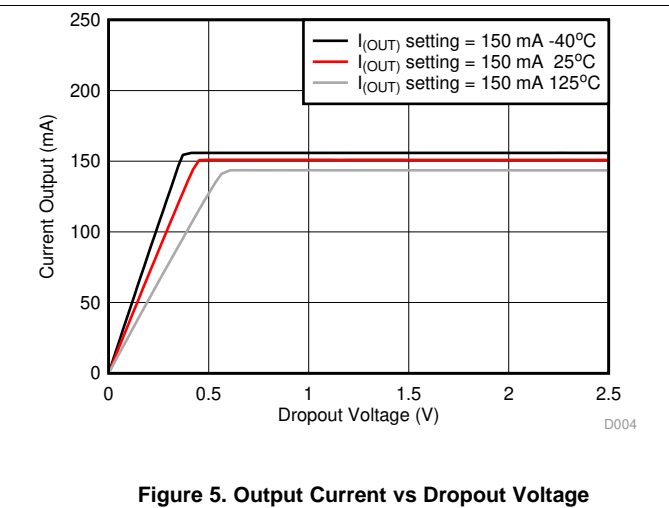
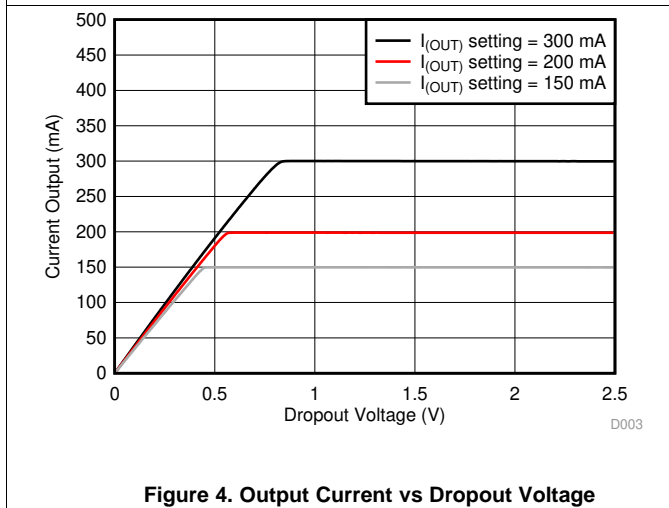
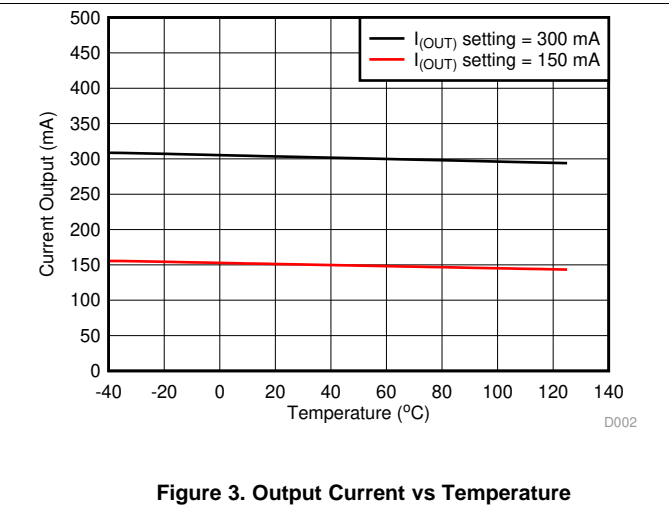
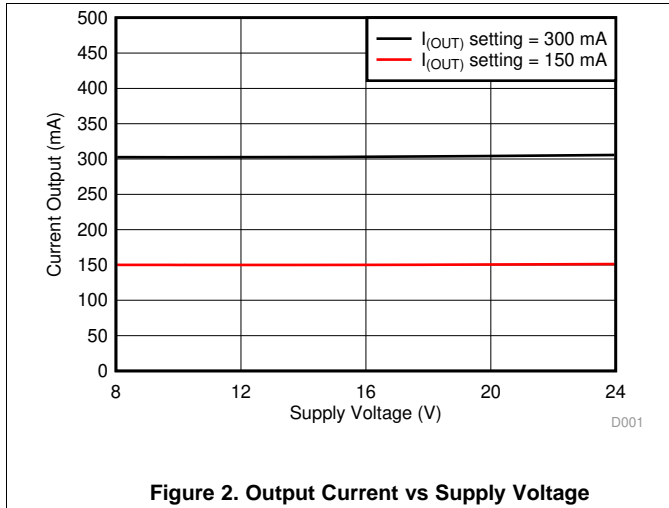
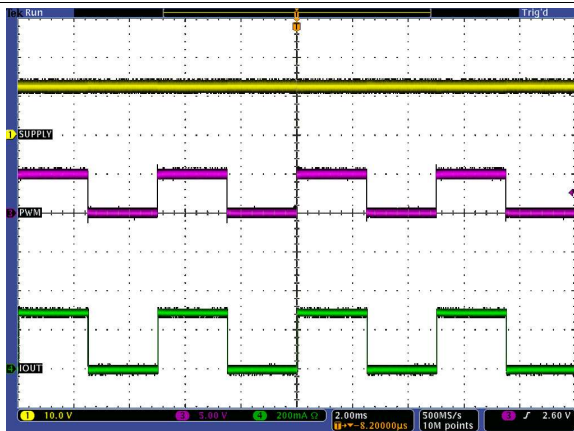

Figure 1. Output Timing Diagram

6.7 Typical Characteristics



Typical Characteristics (continued)



Ch. 1 = $V_{(SUPPLY)}$ Ch. 3 = $V_{(PWM)}$ Ch. 4 = $I_{(OUT)}$
 $f_{(PWM)} = 200 \text{ Hz}$ Duty cycle = 50%

Figure 8. PWM Dimming at 200 Hz

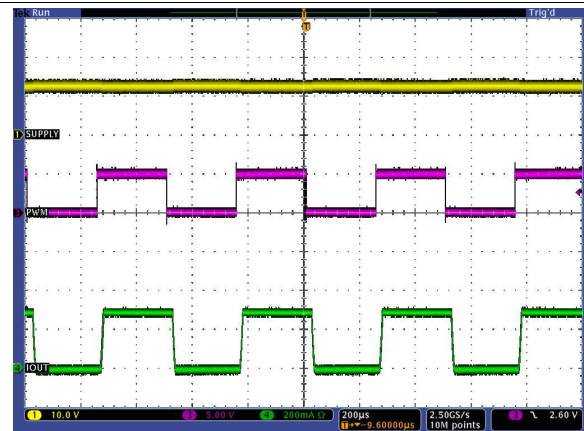

Ch. 1 = $V_{(SUPPLY)}$ Ch. 3 = $V_{(PWM)}$ Ch. 4 = $I_{(OUT)}$
 $f_{(PWM)} = 2 \text{ kHz}$ Duty cycle = 50%

Figure 9. PWM Dimming at 2 kHz

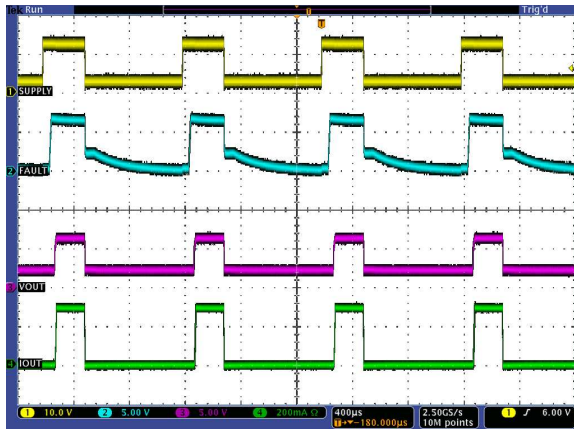

Ch. 1 = $V_{(SUPPLY)}$ Ch. 2 = $\overline{\text{FAULT}}$ Ch. 3 = $V_{(OUT)}$
 Ch. 4 = $I_{(OUT)}$ $f_{(PWM)} = 1000 \text{ Hz}$ Duty cycle = 30%
 SUPPLY dimming between 2.5 V and 12 V $\overline{\text{FAULT}}$ floating

Figure 10. Supply Dimming at 1 kHz

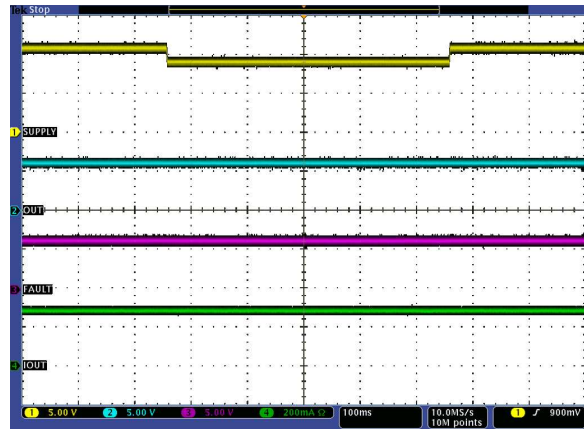

Ch. 1 = SUPPLY Ch. 2 = $V_{(OUT)}$ Ch. 3 = $\overline{\text{FAULT}}$
 Ch. 4 = $I_{(OUT)}$

Figure 11. Transient Undervoltage

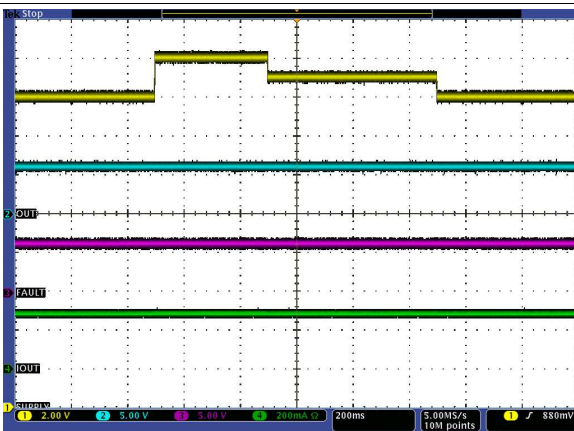

Ch. 1 = SUPPLY Ch. 2 = $V_{(OUT)}$ Ch. 3 = $\overline{\text{FAULT}}$
 Ch. 4 = $I_{(OUT)}$

Figure 12. Transient Overvoltage

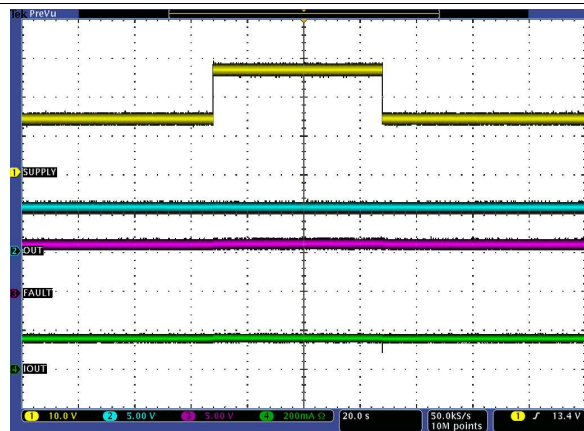

Ch. 1 = SUPPLY Ch. 2 = $V_{(OUT)}$ Ch. 3 = $\overline{\text{FAULT}}$
 Ch. 4 = $I_{(OUT)}$

Figure 13. Jump Start

Typical Characteristics (continued)

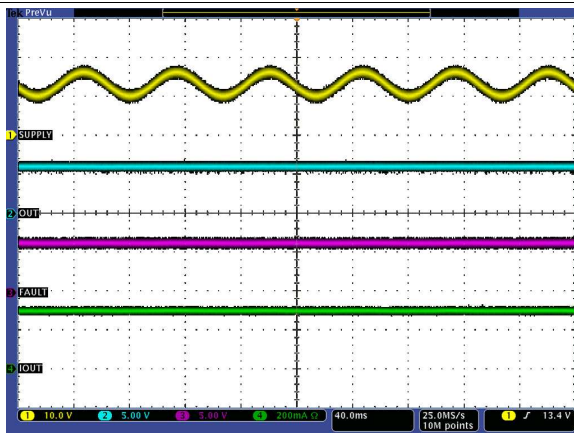

Ch. 1 = SUPPLY Ch. 2 = $V_{(OUT)}$ Ch. 3 = \overline{FAULT}
Ch. 4 = $I_{(OUT)}$

Figure 14. Superimposed Alternating Voltage, 15 Hz

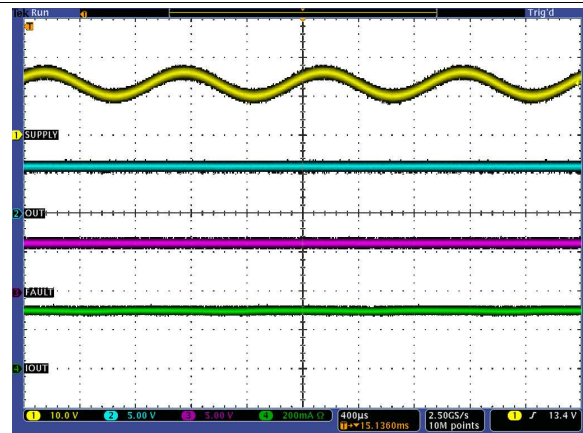

Ch. 1 = SUPPLY Ch. 2 = $V_{(OUT)}$ Ch. 3 = \overline{FAULT}
Ch. 4 = $I_{(OUT)}$

Figure 15. Superimposed Alternating Voltage, 1 kHz

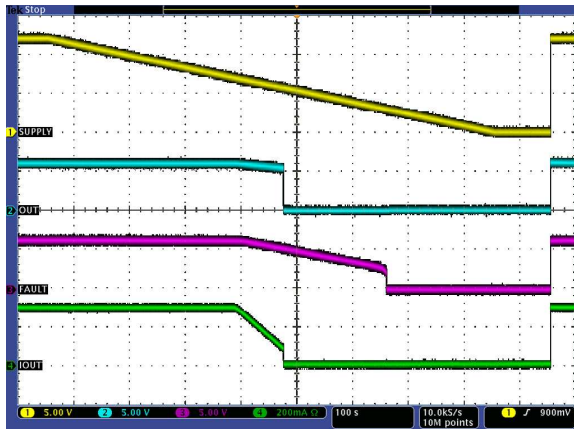

Ch. 1 = SUPPLY Ch. 2 = $V_{(OUT)}$ Ch. 3 = \overline{FAULT}
Ch. 4 = $I_{(OUT)}$

Figure 16. Slow Decrease and Quick Increase of Supply Voltage

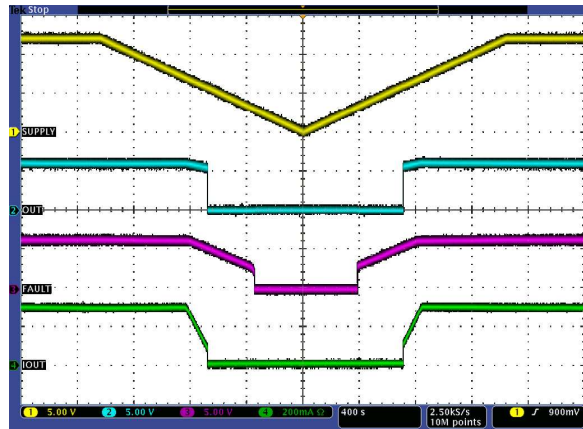

Ch. 1 = SUPPLY Ch. 2 = $V_{(OUT)}$ Ch. 3 = \overline{FAULT}
Ch. 4 = $I_{(OUT)}$

Figure 17. Slow Decrease and Slow Increase of Supply Voltage

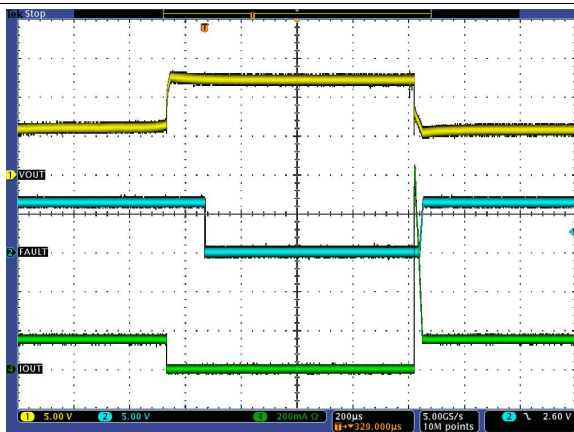

Ch. 1 = $V_{(OUT)}$ Ch. 2 = \overline{FAULT} Ch. 4 = $I_{(OUT)}$

Figure 18. LED Open-Circuit Protection and Recovery

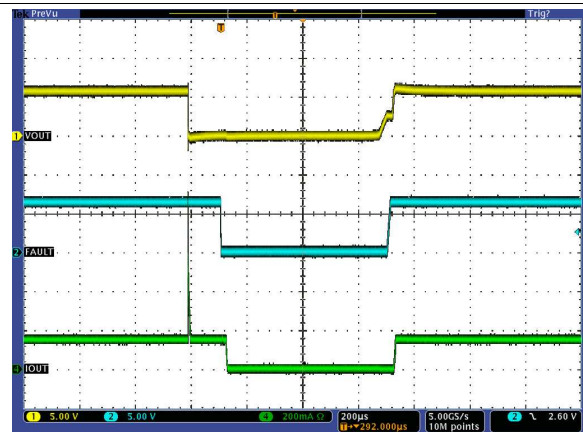

Ch. 1 = $V_{(OUT)}$ Ch. 2 = \overline{FAULT} Ch. 4 = $I_{(OUT)}$

Figure 19. LED Short-Circuit Protection and Recovery

7 Detailed Description

7.1 Overview

The TPS92613-Q1 is one device of single-channel linear LED driver family including TPS92610-Q1, TPS92611-Q1 and TPS92612-Q1. The family provides a simple solution for automotive LED applications. Different package options in the family provide variable current ranges and diagnostic options. The TPS92613-Q1 device in a TO-263 package supports both LED open-circuit detection and short-to-ground detection. The TPS92613-Q1 can be used with other TPS9261x-Q1, TPS9263x-Q1 and TPS92830-Q1 family devices together to realize one-fails-all-fail protection by tying all FAULT pins together as a fault bus.

The current output at OUT pin can be set by an external $R_{(SNS)}$ resistor. Current flows from the supply through the $R_{(SNS)}$ resistor into the integrated current regulation circuit and to the LEDs through OUT pin.

7.2 Functional Block Diagram

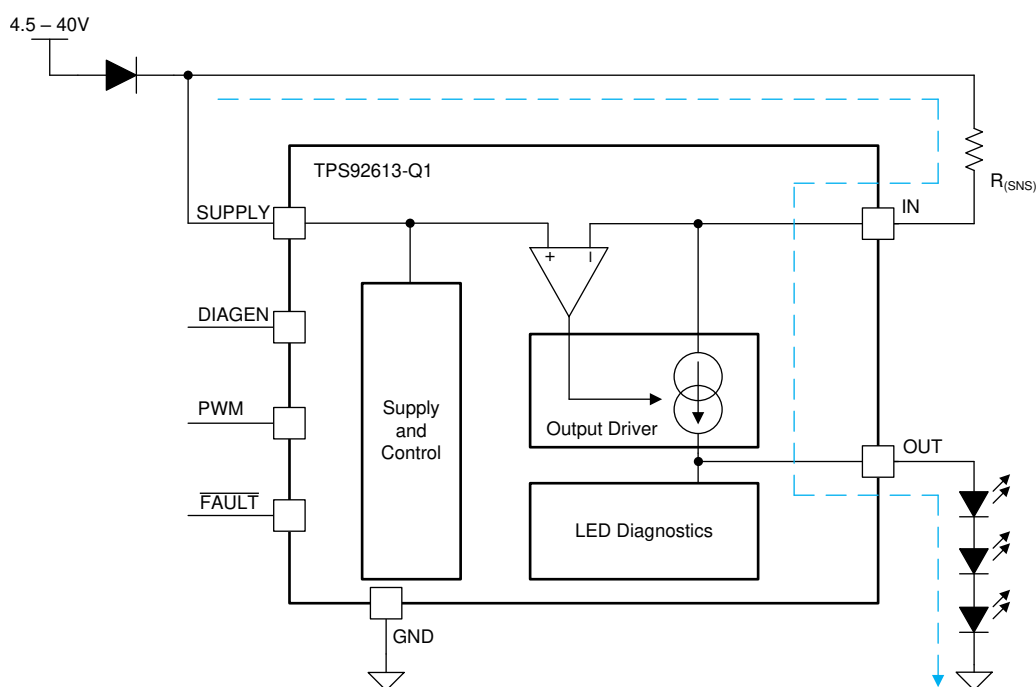

7.3 Feature Description

7.3.1 Power Supply

7.3.1.1 Power-On Reset (POR)

The TPS92613-Q1 device has an internal power-on-reset (POR) function. When power is applied to the SUPPLY pin, the internal POR circuit holds the device in reset state until $V_{(SUPPLY)}$ is above $V_{(POR_rising)}$.

7.3.1.2 Low-Quiescent-Current

The TPS92613-Q1 device consumes minimal quiescent current, less than 250 μ A into SUPPLY when the \overline{FAULT} pin is externally pulled LOW. At the same time, the device shuts down the output driver.

If device detects an internal fault, it pulls down the \overline{FAULT} pin by an internal typical 750- μ A constant current as a fault indication to the fault bus.

Feature Description (continued)

7.3.2 Constant-Current Driver

The TPS92613-Q1 device is a high-side current driver for driving LEDs. The device controls the output current through regulating the voltage drop on an external high-side current-sense resistor, $R_{(SNS)}$. An integrated error amplifier drives an internal power transistor to maintain the voltage drop on the current-sense resistor $R_{(SNS)}$ to $V_{(CS_REG)}$ and therefore regulates the current output to target value. When the output current is in regulation, the current value can be calculated by using Equation 1.

$$I_{(OUT)} = \frac{V_{(CS_REG)}}{R_{(SNS)}}$$

where

- $V_{(CS_REG)} = 98 \text{ mV}$ (typical) (1)

When the supply voltage drops below total LED string forward voltage plus required dropout voltage, $V_{(DROPOUT)}$, the TPS92613-Q1 is not able to deliver enough current output as set by the value of $R_{(SNS)}$, and the voltage across the current-sense resistor $R_{(SNS)}$ is less than $V_{(CS_REG)}$.

7.3.3 PWM Control

The pulse width modulation (PWM) input of the TPS92613-Q1 functions as enable for the output current. When the voltage applied on the PWM pin is higher than $V_{IH(PWM)}$, the output current is enabled. When the voltage applied on PWM pin is lower than $V_{IL(PWM)}$, the output current is disabled as well as the diagnostic features. Besides output current enable and disable function, the PWM input of TPS92613-Q1 also supports adjustment of the average current output for brightness control if the frequency of applied PWM signal is higher than 100 Hz, which is out of visible frequency range of human eyes. TI recommends a 200-Hz PWM signal with 1% to 100% duty cycle input for brightness control. See to Figure 20 for typical PWM dimming application.

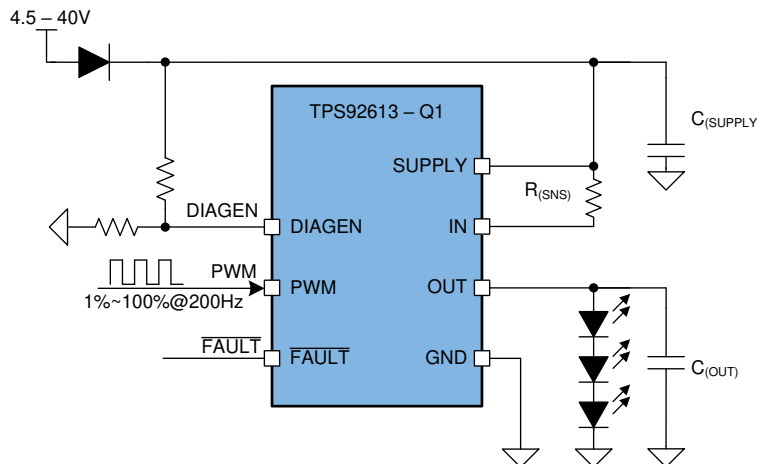

Figure 20. Typical Application Schematic for PWM Dimming

7.3.4 Supply Control

The TPS92613-Q1 supports supply control to turn ON and OFF output current. When the voltage applied on the SUPPLY pin is higher than the LED string forward voltage plus needed $V_{(DROPOUT)}$ at required current, and the PWM pin voltage is high, the output current is turned ON and well regulated. However, if the voltage applied on the SUPPLY pin is lower than $V_{(POR_falling)}$, the output current is turned OFF. With this feature, the power-supply voltage in the designed pattern controls the output current ON/OFF. The brightness can be adjustable if the ON/OFF frequency is fast enough. Because of the high accuracy design of PWM threshold in TPS92613-Q1, TI recommends a resistor divider on the PWM pin to set the SUPPLY threshold higher than LED forward voltage plus $V_{(DROPOUT)}$ as shown in Figure 21. When the voltage on the PWM pin is higher than $V_{IH(PWM)}$, the output current is turned ON. However, when the voltage on the PWM is lower than $V_{IL(PWM)}$, the output current is turned OFF.

Feature Description (continued)

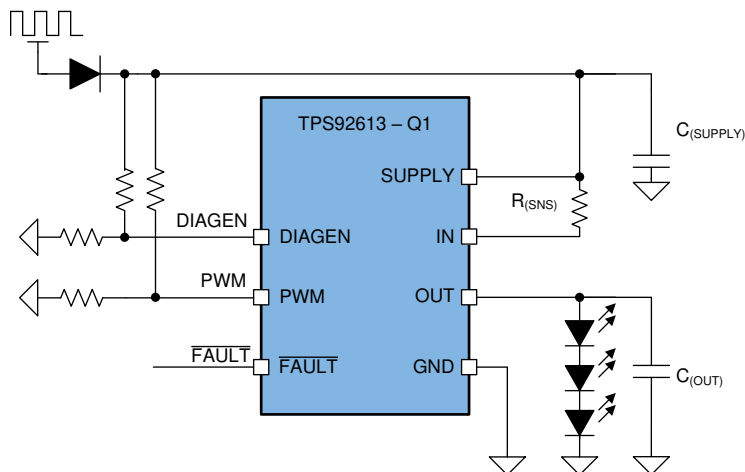

Figure 21. Typical Application Schematic for SUPPLY Control

7.3.5 Diagnostics and Protection

The TPS92613-Q1 device provides advanced diagnostics and fault-protection features for automotive exterior lighting systems. The device is able to detect and protect fault from LED-string short-to-GND, LED-string open-circuit and junction overtemperature scenarios. It also supports a one-fails-all-fail fault bus design that can flexibly fit different regulatory requirements.

7.3.5.1 Open-Circuit Detection

The TPS92613-Q1 device has LED open-circuit detection. The LED open-circuit detection monitors the output voltage when the current output is enabled. The LED open-circuit detection is only enabled when DIAGEN is HIGH. A short-to-battery fault is also detected and recognized as an LED open-circuit fault.

The TPS92613-Q1 monitors dropout-voltage differences between the IN and OUT pins when PWM is HIGH. The voltage difference $V_{(IN)} - V_{(OUT)}$ is compared with the internal reference voltage $V_{(OPEN_th_falling)}$ to detect an LED open-circuit incident. If $V_{(IN)} - V_{(OUT)}$ falls below the $V_{(OPEN_th_falling)}$ voltage longer than the deglitch time of $t_{(OPEN_deg)}$, the device asserts an open-circuit fault. Once an LED open-circuit failure is detected, the internal constant-current sink pulls down the \overline{FAULT} pin voltage. During the deglitch time period, if $V_{(IN)} - V_{(OUT)}$ rises above $V_{(OPEN_th_rising)}$, the deglitch timer is reset.

The TPS92613-Q1 keeps the current output enabled to retry after LED open-circuit fault is detected if the PWM input is HIGH; the device sources a small current $I_{(retry)}$ from IN to OUT when PWM input is LOW. In either scenario, once the fault condition is removed, the device resumes normal operation and releases the \overline{FAULT} pin.

7.3.5.2 Short-to-GND Detection

The TPS92613-Q1 device has LED short-to-GND detection. The LED short-to-GND detection monitors the output voltage when the output current is enabled. Once a short-to-GND LED failure is detected, the device turns off the output channel and retries automatically, regardless of the state of the PWM input. If the retry mechanism detects the removal of the LED short-to-GND fault, the device resumes to normal operation.

The TPS92613-Q1 monitors the $V_{(OUT)}$ voltage and compares it with the internal reference voltage to detect a short-to-GND failure. If $V_{(OUT)}$ falls below $V_{(SG_th_falling)}$ longer than the deglitch time of $t_{(SG_deg)}$, the device asserts the short-to-GND fault and pulls low the \overline{FAULT} pin. During the deglitching time period, if $V_{(OUT)}$ rises above $V_{(SG_th_rising)}$, the timer is reset.

Once the TPS92613-Q1 has asserted a short-to-GND fault, the device turns off the output channel and retries automatically with a small current. During retrying the device sources a small current $I_{(retry)}$ from IN to OUT to pull up the LED loads continuously. Once auto-retry detects output voltage rising above $V_{(SG_th_falling)}$, it clears the short-to-GND fault and resumes to normal operation.

Feature Description (continued)

7.3.5.3 Overtemperature Protection

The TPS92613-Q1 device monitors device junction temperature. When the junction temperature reaches thermal shutdown threshold $T_{(TSD)}$, the output shuts down. Once the junction temperature falls below $T_{(TSD)} - T_{(TSD_HYS)}$, the device recovers to normal operation. During overtemperature protection, the FAULT pin is pulled low.

7.3.5.4 DIAGEN

The TPS92613-Q1 device supports the DIAGEN pin with an accurate threshold to disable the LED open-circuit diagnostic functions. The DIAGEN pin can be used to enable or disable LED open-circuit protection based on SUPPLY pin voltage sensed by an external resistor divider. When the voltage applied on DIAGEN pin is higher than the threshold $V_{IH(DIAGEN)}$, the device enables LED open-circuit diagnosis. When $V_{(DIAGEN)}$ is lower than the threshold $V_{IL(DIAGEN)}$, the device disables LED-open-circuit detection.

Only LED open-circuit detection can be disabled by pulling down the DIAGEN pin. The LED short-to-GND detection and overtemperature protection cannot be turned off by pulling down the DIAGEN pin.

7.3.5.5 Low-Dropout Operation

When the supply voltage drops below LED string total forward voltage plus $V_{(DROPOUT)}$ at required current, the TPS92613-Q1 device operates in low-dropout conditions to deliver current output as close as possible to target value. The actual current output is less than preset value due to insufficient headroom voltage for power transistor. As a result, the voltage across the sense resistor fails to reach the regulation target.

If the TPS92613-Q1 is designed to operate in low-dropout condition, and the open-circuit diagnostics must be disabled by pulling the DIAGEN pin voltage lower than $V_{IL(DIAGEN)}$. Otherwise, the TPS92613-Q1 detects an open-circuit fault and reports a fault indication on the FAULT pin. The DIAGEN pin is used to avoid false diagnostics due to low supply voltage.

In low-dropout operation, a diode in parallel with the sense resistor is recommended to clamp the voltage between SUPPLY and IN (across the sense resistor) in case of a large current pulse during recovery.

7.3.6 FAULT Bus Output With One-Fails-All-Fail

During normal operation, The $\overline{\text{FAULT}}$ pin of TPS92613-Q1 is weakly pulled up by an internal pullup current source, $I_{(\text{FAULT_pullup})}$ higher than $V_{OH(\text{FAULT})}$. If any fault scenario occurs, the $\overline{\text{FAULT}}$ pin is strongly pulled low by the internal pulldown current sink, $I_{(\text{FAULT_pulldown})}$ to report out the fault alarm.

Meanwhile, the TPS92613-Q1 also monitors the $\overline{\text{FAULT}}$ pin voltage internally. If the $\overline{\text{FAULT}}$ pin of the TPS92613-Q1 is pulled low by external current sink below $V_{IL(\text{FAULT})}$, the current output is turned off even though there is no fault detected on owned output. The device does not resume to normal operation until the FAULT pin voltage rises above $V_{IH(\text{FAULT})}$.

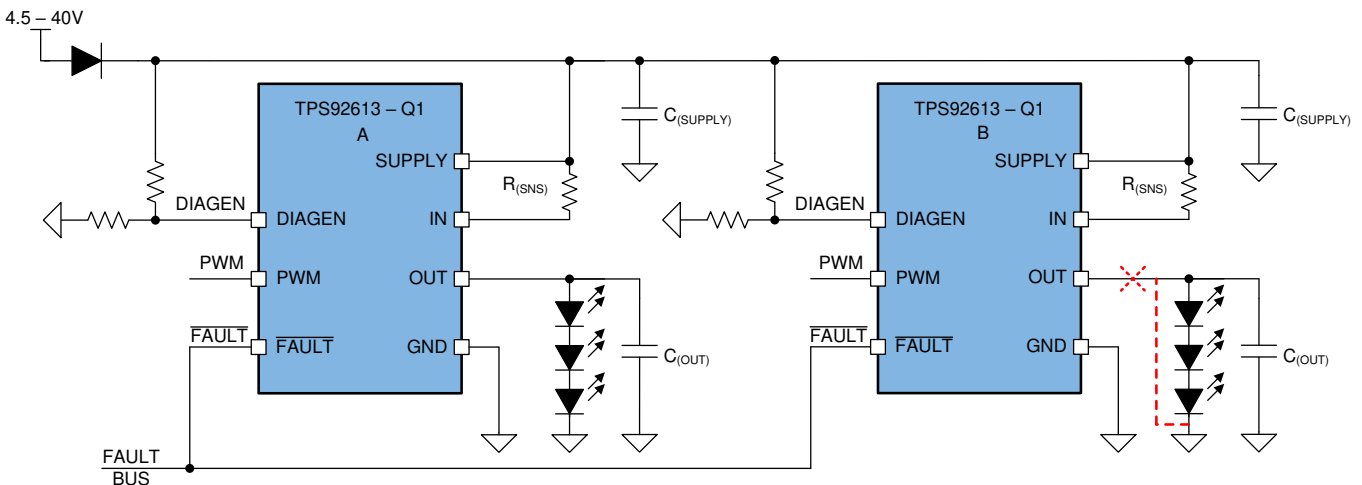

Figure 22. Typical Application Schematic for One-Fails-All-Fail

Feature Description (continued)

Based on this feature, the TPS92613-Q1 device is able to construct a FAULT bus by tying $\overline{\text{FAULT}}$ pins from multiple TPS9261x-Q1, TPS9263x-Q1 or TPS92830-Q1 devices to realize one-fails-all-fail function as [Figure 22](#) showing. The right side TPS92613-Q1 (B) detects either LED open-circuit fault or LED short-to-GND fault and pulls low the FAULT pin. The low voltage on FAULT pin is detected by left side TPS92613-Q1 (A) because the FAULT pins are connected of two devices. The left TPS92613-Q1 (A) turns off the output current as a result.

If the $\overline{\text{FAULT}}$ pin is externally pulled up with a current larger than $I_{(\text{FAULT_pulldown})}$, the one-fails-all-fail function is disabled and only the faulty channel is turned off.

The FAULT bus is able to support up to 15 pieces of TPS9261x-Q1, TPS9263x-Q1, or TPS92830-Q1 devices.

7.3.7 Fault Table

Table 1. Fault Table With DIAGEN = HIGH

FAULT BUS STATUS	FAULT TYPE	DETECTION MECHANISM	CURRENT OUTPUT	DEGLITCH TIME	FAULT BUS	FAULT HANDLING ROUTINE	FAULT RECOVERY
$\overline{\text{FAULT}}$ floating or externally pulled up	Open-circuit or short-to-supply	$V_{(\text{IN})} - V_{(\text{OUT})} < V_{(\text{OPEN_th_falling})}$	On	$t_{(\text{OPEN_deg})}$	Constant-current pulldown	Device works normally with FAULT pin pulled low. Device sources $I_{(\text{retry})}$ current when PWM is LOW. Device keeps output normal when PWM is HIGH.	Auto recovery
	Short-to-ground	$V_{(\text{OUT})} < V_{(\text{SG_th_falling})}$	On	$t_{(\text{SG_deg})}$	Constant-current pulldown	Device turns output off and retries with constant current $I_{(\text{retry})}$, ignoring the PWM input.	Auto recovery
	Overtemperature	$T_J > T_{(\text{TSD})}$	On or off	$t_{(\text{TSD_deg})}$	Constant-current pulldown	Device turns output off.	Auto recovery
Externally pulled low	Device turns output off						

Table 2. Fault Table With DIAGEN = LOW

FAULT BUS STATUS	FAULT TYPE	DETECTION MECHANISM	CURRENT OUTPUT	DEGLITCH TIME	FAULT BUS	FAULT HANDLING ROUTINE	FAULT RECOVERY
$\overline{\text{FAULT}}$ floating or externally pulled up	Open-circuit or short-to-supply	Ignored					
	Short-to-ground	$V_{\text{OUT}} < V_{(\text{SG_th_falling})}$	On	$t_{(\text{SG_deg})}$	Constant-current pulldown	Device turns output off and retries with constant current $I_{(\text{retry})}$, ignoring the PWM input.	Auto recovery
	Overtemperature	$T_J > T_{(\text{TSD})}$	On or off	$t_{(\text{TSD_deg})}$	Constant-current pulldown	Device turns output off.	Auto recovery
Externally pulled low	Device turns output off						

7.4 Device Functional Modes

7.4.1 Undervoltage Lockout, $V_{(\text{SUPPLY})} < V_{(\text{POR_rising})}$

When the device is in undervoltage lockout status, the TPS92613-Q1 device disables all functions until the supply rises above the $V_{(\text{POR_rising})}$ threshold.

7.4.2 Normal Operation $V_{(\text{SUPPLY})} \geq 4.5 \text{ V}$

The device drives an LED string in normal operation. With enough voltage drop across SUPPLY and OUT, the device is able to drive the output in constant-current mode.

7.4.3 Low-Voltage Dropout Operation

When the device drives an LED string in low-dropout operation, if the voltage drop is less than the open-circuit detection threshold, the device may report a false open-circuit fault. TI recommends only enabling the open-circuit detection when SUPPLY voltage is enough higher than LED string voltage to avoid a false open-circuit detection.

7.4.4 Fault Mode

When the device detects an open circuit or a shorted LED, the device tries to pull down the $\overline{\text{FAULT}}$ pin with a constant current. If the FAULT bus is pulled down, the device switches to fault mode and consumes a fault current of $I_{(\text{FAULT})}$.

8 Application and Implementation

NOTE

Information in the following applications sections is not part of the TI component specification, and TI does not warrant its accuracy or completeness. TI's customers are responsible for determining suitability of components for their purposes. Customers should validate and test their design implementation to confirm system functionality.

8.1 Application Information

In automotive lighting applications, thermal performance and LED diagnostics are always design challenges for linear LED drivers.

The TPS92613-Q1 device is capable of detecting LED open-circuit and LED short-circuits. To increase current-driving capability, the TPS92613-Q1 device supports using an external parallel resistor to help dissipate heat as following section [Single-Channel LED Driver With Heat Sharing](#) describes. This method provides a low-cost solution of using external resistors to minimize thermal accumulation on the device itself due to large voltage difference between input voltage and LED string forward voltage, while still keeping high accuracy of the total current output. Note that the one-fails-all-fail feature is not supported by this topology.

8.2 Typical Applications

8.2.1 Single-Channel LED Driver With Diagnostics

The TPS92613-Q1 is an easy-to-use solution for LED driver applications with diagnostics requirements.

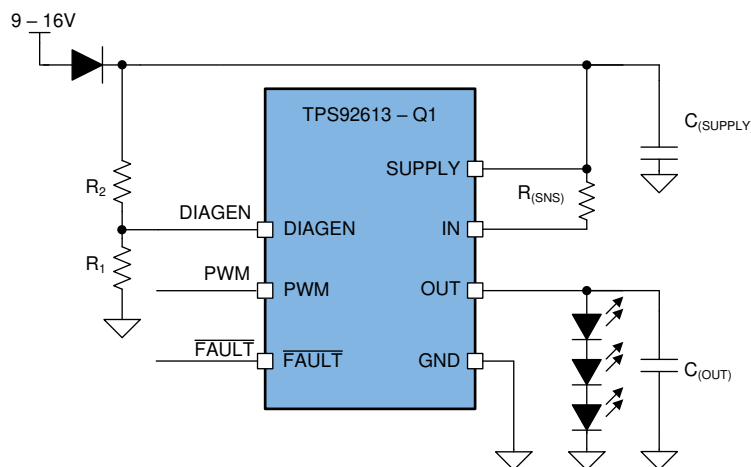

Figure 23. Typical Application Diagram

8.2.1.1 Design Requirements

Input voltage range is from 9 V to 16 V, LED maximum forward voltage $V_{F_MAX} = 2.5$ V, minimum forward voltage $V_{F_MIN} = 1.9$ V, current $I_{(LED)} = 250$ mA. PWM input is adopted for LED brightness adjust and LED ON/OFF control.

8.2.1.2 Detailed Design Procedure

STEP 1: Determine the current setting resistor, $R_{(SNS)}$ value by using [Equation 2](#).

$$R_{(SNS)} = \frac{V_{(CS_REG)}}{I_{(LED)}} = 0.392\Omega$$

where

- $V_{(CS_REG)} = 98$ mV (typical.)
- $I_{(LED)} = 250$ mA

(2)

Typical Applications (continued)

STEP 2: Design the threshold voltage for SUPPLY to enable the LED open-circuit diagnostics and calculate the resistor divider value.

LED-string maximum forward voltage = $3 \times 2.5 \text{ V} = 7.5 \text{ V}$. To avoid the open-circuit fault reported in low-dropout operation conditions, additional headroom between SUPPLY and OUT needs to be considered. The TPS92613-Q1 device must disable open-circuit detection when the supply voltage is below LED-string maximum forward voltage plus maximum $V_{(\text{OPEN_th_rising})}$ and maximum $V_{(\text{CS_REG})}$. The voltage divider resistor, R_1 and R_2 value can be calculated by [Equation 3](#).

$$V_{\text{IL(DIAGEN)}} = \frac{\left(V_{(\text{OPEN_th_rising})} + V_{(\text{CS_REG})} + V_{(\text{OUT})} \right) \times R_1}{R_1 + R_2}$$

where

- $V_{\text{IL(DIAGEN)}} = 1.045 \text{ V}$ (minimum)
 - $V_{(\text{OPEN_th_rising})} = 335 \text{ mV}$ (maximum)
 - $V_{(\text{CS_REG})} = 102.5 \text{ mV}$ (maximum)
 - $R_1 = 10 \text{ k}\Omega$ recommended
- (3)

The calculated result for R_2 is $65.7 \text{ k}\Omega$ when $V_{(\text{OUT})}$ maximum voltage is 7.5 V .

STEP 3: Thermal analysis for the worst application conditions.

Normally the thermal analysis is necessary for linear LED-driver applications to ensure that the operation junction temperature of TPS92613-Q1 is well managed. The total power consumption on the TPS92613-Q1 itself is one important factor determining operation junction temperature, and it can be calculated by using [Equation 4](#). Based on the worst-case analysis for maximum power consumption on device, consider either optimizing PCB layout for better power dissipation as [Layout](#) describes or adding an extra heat-sharing resistor as described in [Single-Channel LED Driver With Heat Sharing](#).

$$P_{(\text{DEV})} = \left(V_{(\text{SUPPLY})} - V_{(\text{CS_REG})} - V_{(\text{OUT})} \right) \times I_{(\text{LED})} + V_{(\text{SUPPLY})} \times I_{(\text{Quiescent})}$$

$$P_{(\text{DEV_MAX})} = (16 - 3 \times 1.9 - 0.098) \times 0.25 + 16 \times 0.00025 = 2.55 \text{ W}$$

where

- $V_{(\text{CS_REG})} = 98 \text{ mV}$ (typical)
 - $I_{(\text{Quiescent})} = 250 \text{ }\mu\text{A}$ (maximum)
- (4)

In this application, the calculated result for maximum power consumption on the TPS92613-Q1 is 2.55 W at $V_{(\text{SUPPLY})} = 16 \text{ V}$ and $I_{(\text{LED})} = 250 \text{ mA}$ conditions.

TI recommends to add capacitors $C_{(\text{SUPPLY})}$ at SUPPLY and $C_{(\text{OUT})}$ at OUT. TI recommends one $1\text{-}\mu\text{F}$ capacitor plus one 100-nF decoupling ceramic capacitor close to the SUPPLY pin for $C_{(\text{SUPPLY})}$ and a 10-nF ceramic capacitor close to the OUT pin for $C_{(\text{OUT})}$. The larger capacitor for $C_{(\text{SUPPLY})}$ or $C_{(\text{OUT})}$ is helpful for EMI and ESD immunity; however, large $C_{(\text{OUT})}$ takes a longer time to charge up the capacitor and may affect PWM dimming performance.

Typical Applications (continued)

8.2.1.3 Application Curves

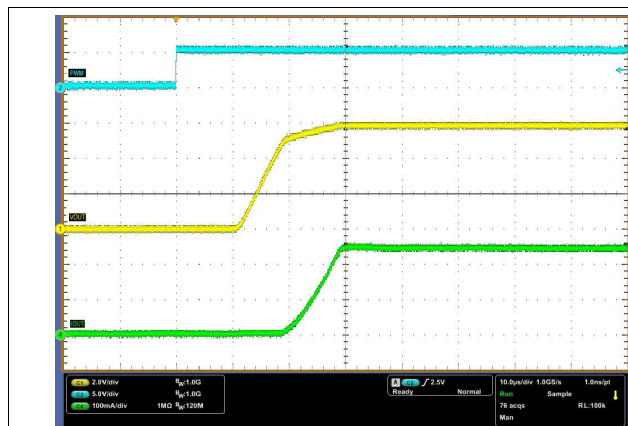

Ch. 1 = $V_{(OUT)}$ Ch. 2 = $V_{(PWM)}$ Ch. 4 = $I_{(OUT)}$

Figure 24. Output Current With PWM Input

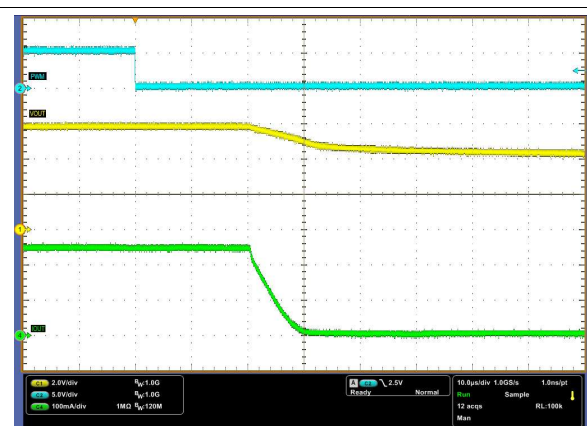

Ch. 1 = $V_{(OUT)}$ Ch. 2 = $V_{(PWM)}$ Ch. 4 = $I_{(OUT)}$

Figure 25. Output Current With PWM Input

8.2.2 Single-Channel LED Driver With Heat Sharing

Using parallel resistors, thermal performance can be improved by balancing current between the TPS92613-Q1 device and the external resistors as follows. As the current-sense resistor controls the total LED string current, the LED string current $I_{(LED)}$ is set by $V_{(CS_REG)} / R_{(SNS)}$, while the TPS92613-Q1 current $I_{(DRIVE)}$ and parallel resistor current $I_{(P)}$ combine to the total current.

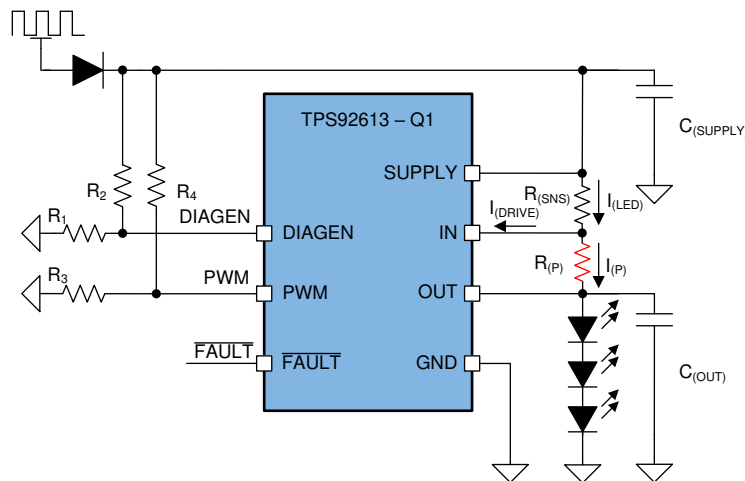

Figure 26. Supply Control With Heat Sharing Resistor

8.2.2.1 Design Requirements

Input voltage range is 9 V to 16 V, LED maximum forward voltage $V_{F_MAX} = 2.5$ V, minimum forward voltage $V_{F_MIN} = 1.9$ V, current $I_{(LED)} = 500$ mA. And supply control is adopted for LED brightness adjust and LED ON/OFF control. The high level of $V_{(SUPPLY)}$ is 9 V to 16 V, and the low level of $V_{(SUPPLY)}$ is between 0 V to 3 V.

Typical Applications (continued)

8.2.2.2 Detailed Design Procedure

Note that the parallel resistor path cannot be shut down by PWM or fault protection. If PWM control is required, TI recommends an application circuit as described in [Figure 27](#).

In linear LED driver applications, the large input voltage variation generates the most of the thermal concerns. The resistor current, as indicated by Ohm's law, depends on the voltage across the external resistors. The TPS92613-Q1 controls the driver current $I_{(DRIVE)}$ to attain the desired total current. If $I_{(P)}$ increases, the TPS92613-Q1 device decreases $I_{(DRIVE)}$ to compensate, and vice versa.

While in low-dropout operation, the voltage across the $R_{(P)}$ resistor may be close to zero, so that almost no current can flow through the external resistor $R_{(P)}$.

When the input voltage is high, the parallel-resistor current $I_{(P)}$ is proportional to the voltage across the parallel resistor $R_{(P)}$. The parallel resistor $R_{(P)}$ takes the majority of the total string current, generating maximum heat.

In this case, the parallel resistor value must be carefully calculated to ensure that 1) enough output current is achieved in low-dropout operation, 2) thermal dissipation for both the TPS92613-Q1 device and the resistor is within their thermal dissipation limits, and 3) device current in the high-voltage mode is above the minimal output-current requirement.

STEP 1: Determine the current setting resistor, $R_{(SNS)}$ value by using [Equation 5](#).

$$R_{(SNS)} = \frac{V_{(CS_REG)}}{I_{(LED)}} = 0.196\Omega$$

where

- $V_{(CS_REG)} = 98 \text{ mV}$ (typical)
 - $I_{(LED)} = 500 \text{ mA}$
- (5)

The calculated result for $R_{(SNS)}$ is 0.196Ω .

STEP 2: Calculate the parallel resistor, $R_{(P)}$ value by using [Equation 6](#).

The parallel resistor $R_{(P)}$ is recommended to consume 50% of the total current at maximum supply voltage.

$$R_{(P)} = \frac{V_{(SUPPLY)} - V_{(CS_REG)} - V_{(OUT)}}{0.5 \times I_{(LED)}} = \frac{16 - 0.098 - 3 \times 1.9}{0.5 \times 0.5} \approx 40\Omega$$

where

- $V_{(CS_REG)} = 98 \text{ mV}$ (typical)
 - $I_{(LED)} = 500 \text{ mA}$
- (6)

The calculated result for $R_{(P)}$ is about 40Ω at $V_{(SUPPLY)} = 16 \text{ V}$.

STEP 3: Design the threshold voltage for SUPPLY to enable the LED open-circuit diagnostics and calculate voltage divider resistor value for R_1 and R_2 .

LED-string maximum forward voltage = $3 \times 2.5 \text{ V} = 7.5 \text{ V}$. To avoid the open-circuit fault reported in low-dropout operation conditions, additional headroom between SUPPLY and OUT needs to be considered. The TPS92613-Q1 device must disable open-circuit detection when the supply voltage is below LED-string maximum forward voltage plus maximum $V_{(OPEN_th_rising)}$ and maximum $V_{(CS_REG)}$. The voltage divider resistor, R_1 and R_2 value can be calculated by [Equation 7](#).

$$V_{IL(DIAGEN)} = \frac{(V_{(OPEN_th_rising)} + V_{(CS_REG)} + V_{(OUT)}) \times R_1}{R_1 + R_2}$$

where

- $V_{IL(DIAGEN)} = 1.045 \text{ V}$ (minimum)
 - $V_{(OPEN_th_rising)} = 335 \text{ mV}$ (maximum)
 - $V_{(CS_REG)} = 102.5 \text{ mV}$ (maximum)
 - $R_1 = 10 \text{ k}\Omega$ recommended
- (7)

Typical Applications (continued)

The calculated result for R_2 is 65.7 k Ω when $V_{(OUT)}$ maximum voltage is 7.5 V.

STEP 4: Design the threshold voltage for PWM to enable current output and calculate voltage divider resistor value for R_3 and R_4 .

Because the supply control is adopted for the LED ON/OFF and brightness control, a pulse square voltage with power capability is applied on the SUPPLY pin to enable and disable current output to OUT. In order to ensure the current output of TPS92613-Q1 is fully enabled when applied voltage on SUPPLY pin is high enough and the current output is truly shutdown when the applied voltage goes low. A voltage divider from supply to control PWM needs to be designed to setup a threshold of supply voltage. The resistor R_3 and R_4 of voltage divider can be calculated by [Equation 8](#).

$$V_{IL(PWM)} = \frac{V_{(SUPPLY)} \times R_3}{R_3 + R_4}$$

where

- $V_{IL(PWM)} = 1.24$ V (maximum)
 - $R_3 = 10$ k Ω recommended
- (8)

The calculated result for R_4 is 30.5 k Ω if LED must be turned on when $V_{(SUPPLY)}$ voltage is higher than 5 V.

STEP 5: Thermal analysis for the worst application conditions.

The total device power consumption can be calculated by [Equation 9](#).

$$P_{(DEV)} = \left(V_{(SUPPLY)} - V_{(CS_REG)} - V_{(OUT)} \right) \times \left(I_{(LED)} - \frac{V_{(SUPPLY)} - V_{(CS_REG)} - V_{(OUT)}}{R_{(P)}} \right) + V_{(SUPPLY)} \times I_{(Quiescent)}$$

$$P_{(DEV_MAX)} = (16 - 0.098 - 3 \times 1.9) \times \left(0.5 - \frac{16 - 0.098 - 3 \times 1.9}{40} \right) + 16 \times 0.00025 = 2.50W$$

where

- $V_{(CS_REG)} = 98$ mV (typical)
 - $I_{(Quiescent)} = 250$ μ A (maximum)
- (9)

The calculated maximum power consumption on the TPS61193-Q1 is 2.5 W at $V_{(SUPPLY)} = 16$ V, $V_{(OUT)} = 3 \times 1.9$ V = 5.7 V and $I_{(LED)} = 500$ mA.

The power consumption on resistor $R_{(P)}$ can be calculated through [Equation 10](#).

$$P_{(RP)} = \frac{\left(V_{(SUPPLY)} - V_{(CS_REG)} - V_{(OUT)} \right)^2}{R_{(P)}}$$

$$P_{(RP_MAX)} = \frac{(16 - 3 \times 1.9 - 0.098)^2}{40} = 2.6W$$

where

- $V_{(CS_REG)} = 98$ mV (Typ.)
- (10)

The calculated maximum power consumption on the 40 Ω , $R_{(P)}$ parallel resistor is 2.6 W at $V_{(SUPPLY)} = 16$ V and $V_{(OUT)} = 3 \times 1.9$ V = 5.7 V.

TI recommends adding capacitors $C_{(SUPPLY)}$ at SUPPLY and $C_{(OUT)}$ at OUT. One 1- μ F capacitor plus one 100-nF decoupling ceramic capacitor close to the SUPPLY pin is recommended for $C_{(SUPPLY)}$, and a 10-nF ceramic capacitor close to the OUT pin is recommended for $C_{(OUT)}$. The larger capacitor for $C_{(SUPPLY)}$ or $C_{(OUT)}$ is helpful for EMI and ESD immunity, however large $C_{(OUT)}$ takes a longer time to charge up the capacitor and could affect PWM dimming performance.

Typical Applications (continued)

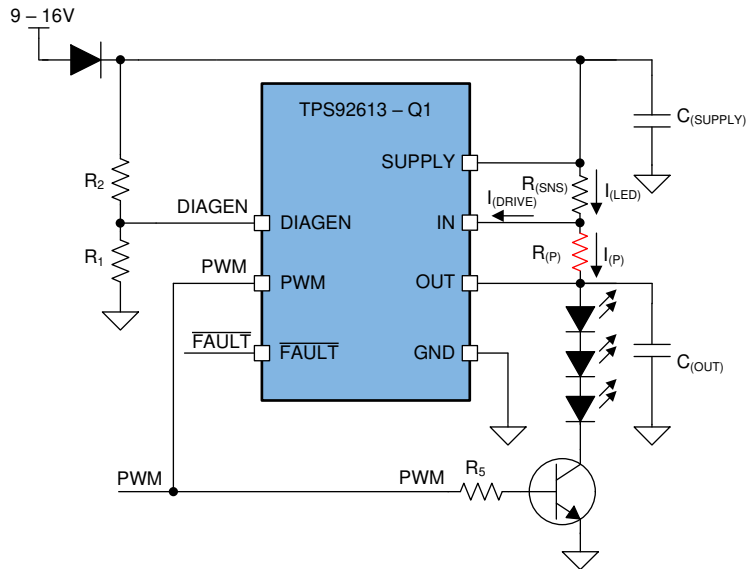
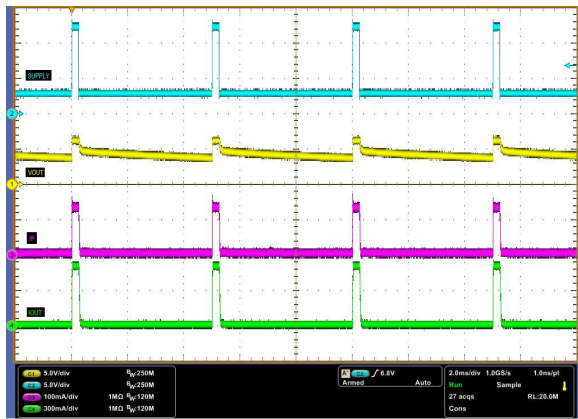

Figure 27. PWM Control With Heat Sharing Resistor

For PWM control scenarios, a NPN bipolar transistor with a base current-limiting resistor, R_5 can modulate the output current together with the device PWM function as Figure 27. The resistor value of R_5 needs to be calculated based on the applied PWM voltage and β value of selected NPN transistor.

Typical Applications (continued)

8.2.2.3 Application Curves



Ch. 1 = $V_{(SUPPLY)}$ Ch. 2 = $V_{(OUT)}$ Ch. 3 = $I_{(P)}$
 Ch. 4 = $I_{(LED)}$ $F_{(SUPPLY)} = 200 \text{ Hz}$ Duty Cycle = 5%
 $V_{(SUPPLYHI)} = 12 \text{ V}$ $V_{(SUPPLYLO)} = 2.5 \text{ V}$

Figure 28. Pulse Supply Control Output Current (D = 5%)

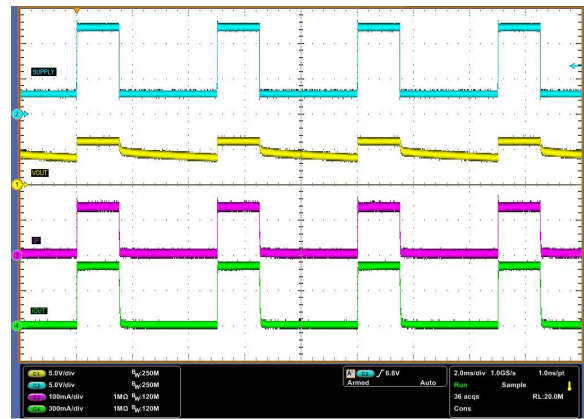

Ch. 1 = $V_{(SUPPLY)}$ Ch. 2 = $V_{(OUT)}$ Ch. 3 = $I_{(P)}$
 Ch. 4 = $I_{(LED)}$ $F_{(SUPPLY)} = 200 \text{ Hz}$ Duty Cycle = 30%
 $V_{(SUPPLYHI)} = 12 \text{ V}$ $V_{(SUPPLYLO)} = 2.5 \text{ V}$

Figure 29. Pulse Supply Control Output Current (D = 30%)

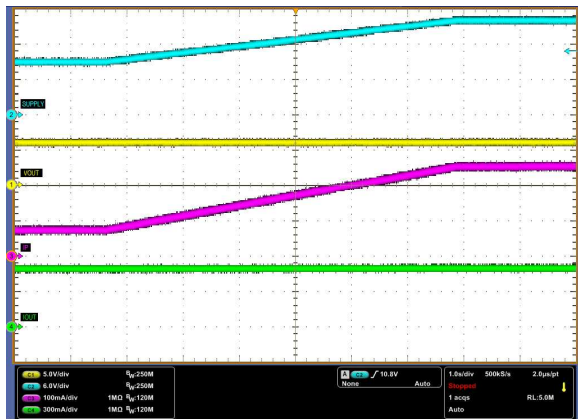

Ch. 1 = $V_{(SUPPLY)}$ Ch. 2 = $V_{(OUT)}$ Ch. 3 = $I_{(P)}$
 Ch. 4 = $I_{(LED)}$ $V_{(SUPPLY)}$ increases from 9 V to 16 V

Figure 30. Constant Output Current With Supply Voltage Increasing

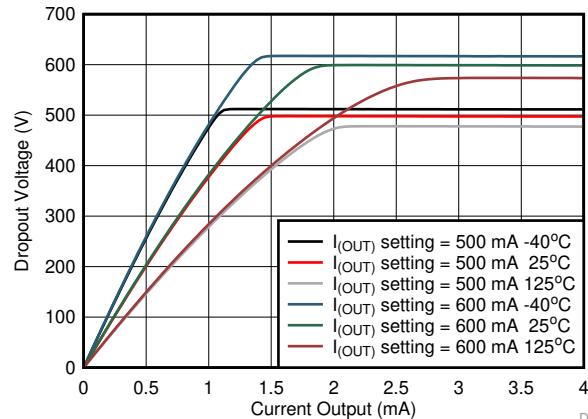

Figure 31. Output Current vs Dropout Voltage

D007

9 Power Supply Recommendations

The TPS92613-Q1 is designed to operate from an automobile electrical power system within the range specified in the *Recommended Operating Conditions*. The $V_{(SUPPLY)}$ input must be protected from reverse voltage and voltage dump condition over 40 V. The impedance of the input supply rail must be low enough that the input current transient does not cause drop below LED string required forward voltage. If the input supply is connected with long wires, additional bulk capacitance may be required in addition to normal input capacitor.

10 Layout

10.1 Layout Guidelines

Thermal dissipation is the primary consideration for TPS92613-Q1 layout. TI recommends large thermal dissipation area connected to thermal pads with multiple thermal vias.

10.2 Layout Example

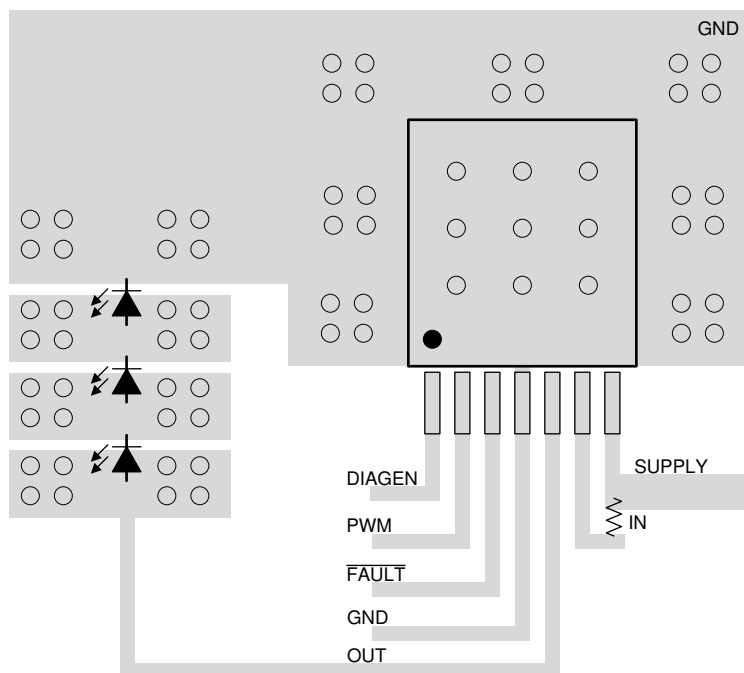

Figure 32. TPS92613-Q1 Example Layout Diagram

11 Device and Documentation Support

11.1 Documentation Support

11.1.1 Related Documentation

For related documentation see the following:

- [TPS92610-Q1 Automotive Single-Channel Linear LED Driver](#)
- [TPS92611-Q1 Automotive Single-Channel Linear LED Driver](#)
- [TPS92612-Q1 Automotive Single-Channel Linear LED Driver](#)
- [TPS92610-Q1 EVM User's Guide](#)
- [How to Calculate TPS92630-Q1 Maximum Output Current for Automotive Exterior Lighting Applications](#)
- [Automotive Linear LED Driver Reference Design for Center High-mounted Stop Lamp \(CHMSL\) product folder](#)
- [Automotive Linear LED Driver Reference Design for Center High-mounted Stop Lamp \(CHMSL\) reference design guide](#)

11.2 Receiving Notification of Documentation Updates

To receive notification of documentation updates, navigate to the device product folder on ti.com. In the upper right corner, click on *Alert me* to register and receive a weekly digest of any product information that has changed. For change details, review the revision history included in any revised document.

11.3 Support Resources

[TI E2E™ support forums](#) are an engineer's go-to source for fast, verified answers and design help — straight from the experts. Search existing answers or ask your own question to get the quick design help you need.

Linked content is provided "AS IS" by the respective contributors. They do not constitute TI specifications and do not necessarily reflect TI's views; see TI's [Terms of Use](#).

11.4 Trademarks

E2E is a trademark of Texas Instruments.

All other trademarks are the property of their respective owners.

11.5 Electrostatic Discharge Caution



This integrated circuit can be damaged by ESD. Texas Instruments recommends that all integrated circuits be handled with appropriate precautions. Failure to observe proper handling and installation procedures can cause damage.

ESD damage can range from subtle performance degradation to complete device failure. Precision integrated circuits may be more susceptible to damage because very small parametric changes could cause the device not to meet its published specifications.

11.6 Glossary

[SLYZ022](#) — *TI Glossary*.

This glossary lists and explains terms, acronyms, and definitions.

12 Mechanical, Packaging, and Orderable Information

The following pages include mechanical, packaging, and orderable information. This information is the most-current data available for the designated device. This data is subject to change without notice and without revision of this document. For browser-based versions of this data sheet, see the left-hand navigation pane.

PACKAGING INFORMATION

Orderable part number	Status (1)	Material type (2)	Package Pins	Package qty Carrier	RoHS (3)	Lead finish/ Ball material (4)	MSL rating/ Peak reflow (5)	Op temp (°C)	Part marking (6)
TPS92613QNDRRQ1	Active	Production	TO-263 (NDR) 7	1000 LARGE T&R	Yes	SN	Level-3-260C-168 HR	-40 to 125	TPS92613Q
TPS92613QNDRRQ1.A	Active	Production	TO-263 (NDR) 7	1000 LARGE T&R	Yes	SN	Level-3-260C-168 HR	-40 to 125	TPS92613Q

(1) **Status:** For more details on status, see our [product life cycle](#).

(2) **Material type:** When designated, preproduction parts are prototypes/experimental devices, and are not yet approved or released for full production. Testing and final process, including without limitation quality assurance, reliability performance testing, and/or process qualification, may not yet be complete, and this item is subject to further changes or possible discontinuation. If available for ordering, purchases will be subject to an additional waiver at checkout, and are intended for early internal evaluation purposes only. These items are sold without warranties of any kind.

(3) **RoHS values:** Yes, No, RoHS Exempt. See the [TI RoHS Statement](#) for additional information and value definition.

(4) **Lead finish/Ball material:** Parts may have multiple material finish options. Finish options are separated by a vertical ruled line. Lead finish/Ball material values may wrap to two lines if the finish value exceeds the maximum column width.

(5) **MSL rating/Peak reflow:** The moisture sensitivity level ratings and peak solder (reflow) temperatures. In the event that a part has multiple moisture sensitivity ratings, only the lowest level per JEDEC standards is shown. Refer to the shipping label for the actual reflow temperature that will be used to mount the part to the printed circuit board.

(6) **Part marking:** There may be an additional marking, which relates to the logo, the lot trace code information, or the environmental category of the part.

Multiple part markings will be inside parentheses. Only one part marking contained in parentheses and separated by a "~" will appear on a part. If a line is indented then it is a continuation of the previous line and the two combined represent the entire part marking for that device.

Important Information and Disclaimer: The information provided on this page represents TI's knowledge and belief as of the date that it is provided. TI bases its knowledge and belief on information provided by third parties, and makes no representation or warranty as to the accuracy of such information. Efforts are underway to better integrate information from third parties. TI has taken and continues to take reasonable steps to provide representative and accurate information but may not have conducted destructive testing or chemical analysis on incoming materials and chemicals. TI and TI suppliers consider certain information to be proprietary, and thus CAS numbers and other limited information may not be available for release.

In no event shall TI's liability arising out of such information exceed the total purchase price of the TI part(s) at issue in this document sold by TI to Customer on an annual basis.

TAPE AND REEL INFORMATION

QUADRANT ASSIGNMENTS FOR PIN 1 ORIENTATION IN TAPE



*All dimensions are nominal

Device	Package Type	Package Drawing	Pins	SPQ	Reel Diameter (mm)	Reel Width W1 (mm)	A0 (mm)	B0 (mm)	K0 (mm)	P1 (mm)	W (mm)	Pin1 Quadrant
TPS92613QNDRRQ1	TO-263	NDR	7	1000	330.0	24.4	10.6	15.4	2.45	12.0	24.0	Q2

TAPE AND REEL BOX DIMENSIONS

*All dimensions are nominal

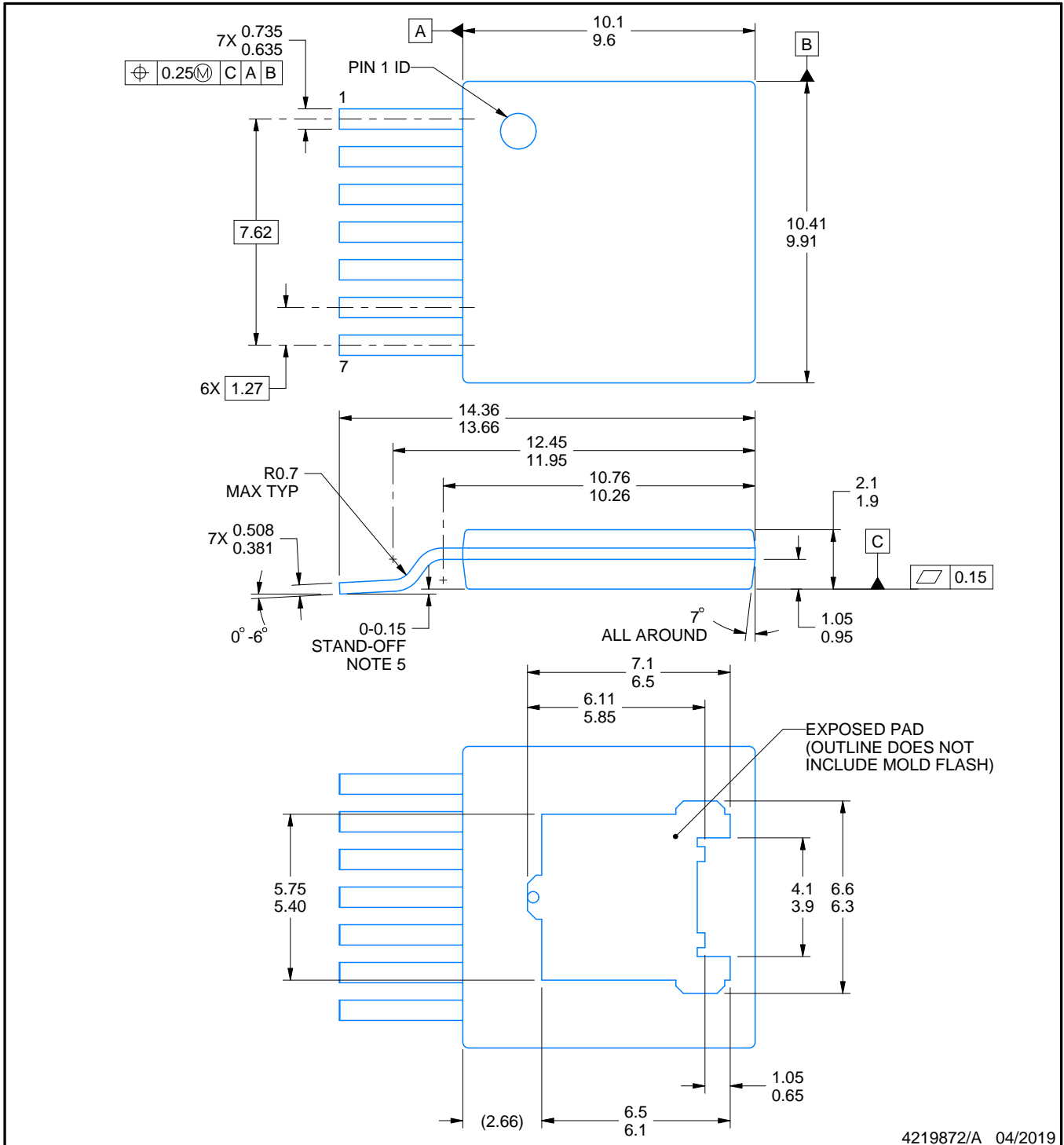
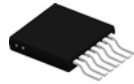
Device	Package Type	Package Drawing	Pins	SPQ	Length (mm)	Width (mm)	Height (mm)
TPS92613QNDRRQ1	TO-263	NDR	7	1000	356.0	356.0	45.0



4219872/A 04/2019

NOTES:

1. All linear dimensions are in millimeters. Any dimensions in parenthesis are for reference only. Dimensioning and tolerancing per ASME Y14.5M.
2. This drawing is subject to change without notice.
3. Features may not exist and shape may vary per different assembly sites.
4. Reference JEDEC registration TO-279B.
5. Under all conditions, leads must not be above Datum C

EXAMPLE BOARD LAYOUT

NDR0007A

TO-263 - 2.25 mm max height

TO-263

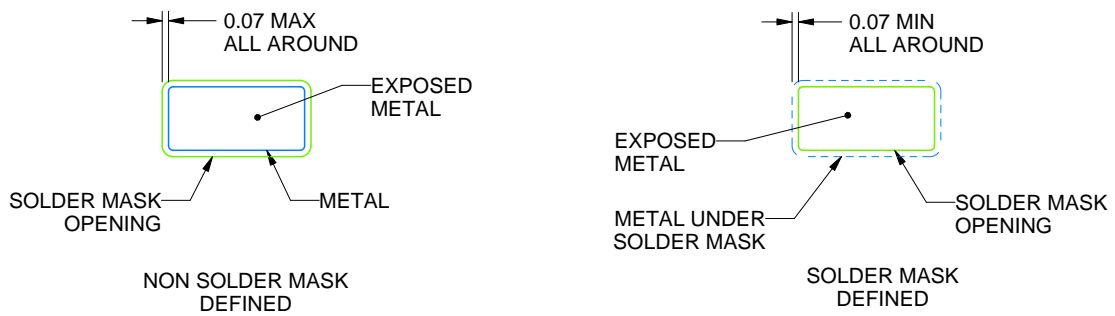
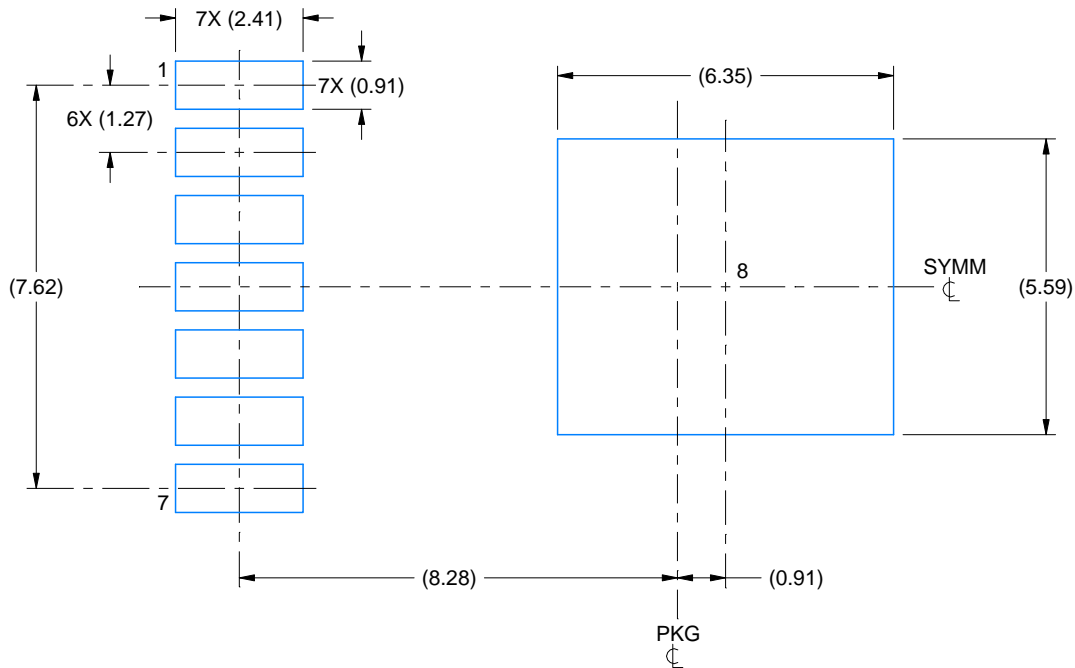

SOLDER MASK DETAILS

4219872/A 04/2019

NOTES: (continued)

6. This package is designed to be soldered to a thermal pad on the board. For more information, see Texas Instruments literature numbers SLMA002 (www.ti.com/lit/slm002) and SLMA004 (www.ti.com/lit/slma004).
7. Vias are optional depending on application, refer to device data sheet. It is recommended that vias under paste be filled, plugged or tented.

EXAMPLE STENCIL DESIGN

NDR0007A

TO-263 - 2.25 mm max height

TO-263

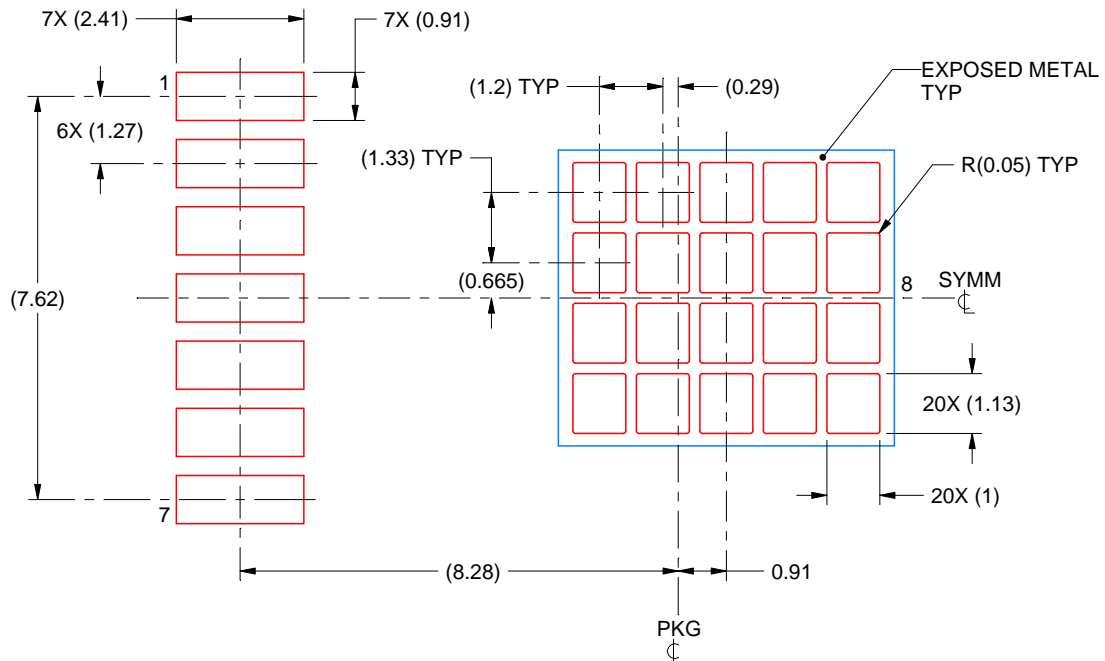

SOLDER PASTE EXAMPLE
BASED ON 0.125 mm THICK STENCIL

EXPOSED PAD
64% PRINTED SOLDER COVERAGE BY AREA
SCALE:7X

4219872/A 04/2019

NOTES: (continued)

8. Laser cutting apertures with trapezoidal walls and rounded corners may offer better paste release. IPC-7525 may have alternate design recommendations.
9. Board assembly site may have different recommendations for stencil design.

IMPORTANT NOTICE AND DISCLAIMER

TI PROVIDES TECHNICAL AND RELIABILITY DATA (INCLUDING DATASHEETS), DESIGN RESOURCES (INCLUDING REFERENCE DESIGNS), APPLICATION OR OTHER DESIGN ADVICE, WEB TOOLS, SAFETY INFORMATION, AND OTHER RESOURCES "AS IS" AND WITH ALL FAULTS, AND DISCLAIMS ALL WARRANTIES, EXPRESS AND IMPLIED, INCLUDING WITHOUT LIMITATION ANY IMPLIED WARRANTIES OF MERCHANTABILITY, FITNESS FOR A PARTICULAR PURPOSE OR NON-INFRINGEMENT OF THIRD PARTY INTELLECTUAL PROPERTY RIGHTS.

These resources are intended for skilled developers designing with TI products. You are solely responsible for (1) selecting the appropriate TI products for your application, (2) designing, validating and testing your application, and (3) ensuring your application meets applicable standards, and any other safety, security, regulatory or other requirements.

These resources are subject to change without notice. TI grants you permission to use these resources only for development of an application that uses the TI products described in the resource. Other reproduction and display of these resources is prohibited. No license is granted to any other TI intellectual property right or to any third party intellectual property right. TI disclaims responsibility for, and you fully indemnify TI and its representatives against any claims, damages, costs, losses, and liabilities arising out of your use of these resources.

TI's products are provided subject to [TI's Terms of Sale](#), [TI's General Quality Guidelines](#), or other applicable terms available either on [ti.com](#) or provided in conjunction with such TI products. TI's provision of these resources does not expand or otherwise alter TI's applicable warranties or warranty disclaimers for TI products. Unless TI explicitly designates a product as custom or customer-specified, TI products are standard, catalog, general purpose devices.

TI objects to and rejects any additional or different terms you may propose.

Copyright © 2026, Texas Instruments Incorporated

Last updated 10/2025