

PRODUCT GUIDE

General-Purpose Small-Signal Surface-Mount Devices

Transistors, MOSFETs, ESD-Protection Diodes, Schottky Barrier Diodes,
L-MOS (1- to 3-Gate Logic ICs), LDOs, Operational Amplifiers, Digital-Output Magnetic Sensors



• SEMICONDUCTOR •

<http://www.semicon.toshiba.co.jp/eng>

C O N T E N T S

1	New Products	3
	Semi-power P-channel MOSFETs for quick-charger applications for cell phones, digital still cameras and game consoles	3
	LVP & SHS 1- to 3-Gate Logic (L-MOS) Series	3
	200-mA CMOS LDO Regulators in a Ultra-Small Package (Single-Output)	4
	Digital-Output Magnetic Sensors	4
	520 and 521 Small-Signal Schottky Barrier Diode (SBD) Series	5
	Low-Noise CMOS Op Amp: TC75S63TU	5
2	MOSFETs in Ultra-Small Packages	6
2.1	New Products: MOSFETs in a 2 x 2 mm LGA UDFN6 Package	6
2.2	Roadmap for Toshiba MOSFET Development	7
2.3	Application Examples and Block Diagrams	8
2.4	Semi-Power MOSFET Lineup	9
2.5	Standard MOSFET Series (I _b < 500 mA)	13
3	L-MOS(1- to 3-Gate Logic ICs)	14
3.1	Outlines of L-MOS	14
3.2	New Product Information	15
3.3	L-MOS Performance Comparisons	20
3.4	Typical Characteristics for Low-Voltage Logic Series	23
3.5	Product Lineup by Series and Package	24
3.6	Pin Assignments	26
4	LDO(Low-Dropout Regulators)	28
4.1	CMOS LDO Regulators	28
4.2	Bipolar LDO Regulators	32
5	Digital-Output Magnetic Sensors	34
6	Analog Switch	37
7	Op Amp and Comparator ICs	38
7.1	Low-Noise CMOS Op Amp	38
7.2	New Small Package, CST	38
7.3	Open-Drain Comparators	39
7.4	Full-Range Input/Output Op Amps	39
7.5	Product Lineup (CMOS Type)	40
7.6	Product Lineup (Bipolar Type)	41
8	Small-Signal Diodes	42
8.1	Switching Diodes	42
8.2	Schottky Barrier Diodes (SBDs)	43
8.3	New Product Information	46
8.4	ESD-Protection Diodes	48
9	Small-Signal Transistors	52
9.1	General-purpose Transistors	52
9.2	Bias Resistor Built-in Transistors (BRTs)	54
9.3	Multi-Chip Discrete Devices	58
10	List of Devices Fabricated Outside Japan	59
11	List of the Recommended New Devices	68
12	Packaging Information	70
13	Board Assembly	77
14	Part Naming Conventions	78

Semi-power P-channel MOSFETs for quick-charger applications for cell phones, digital still cameras and game consoles

Cell phones, digital still cameras and game consoles have become more and more sophisticated; they now come equipped with a battery pack that has an increasingly higher energy capacity. To meet the requirements for shorter battery charge cycles, the charge control MOSFET must have higher current and lower on-resistance ratings. To address these needs, Toshiba has developed, using a new process, many P-channel MOSFETs. Our products offers a wide range of voltage, current, on-resistance and packaging options.

Applications

Power supply switches in portable equipment, cell phones, digital still cameras, digital video cameras, game consoles and Portable audio player

Product Lineup

New Product

Package	Part Number	V _{bss} (V)	V _{gss} (V)	I _b (A)	R _{DS(ON)} Max (mΩ)					C _{iss} (pF)
					V _{GS} = 1.2 V	V _{GS} = 1.5 V	V _{GS} = 1.8 V	V _{GS} = 2.5 V	V _{GS} = 4.5 V	
SOT-23F	SSM3J328R	-20	±8	-6.0	—	88.4	56.0	39.7	29.8	840
	SSM3J332R	-30	±12	-6.0	—	—	144	72	50	560
UDFN6B	SSM6J501NU	-20	±8	-10	—	43	26.5	19	15.3	2600
	SSM6J502NU	-20	±8	-6.0	—	60.5	38.4	28.3	23.1	1800
	SSM6J503NU	-20	±8	-6.0	—	89.6	57.9	41.7	32.4	840
UF6	SSM6J409TU	-20	±8	-9.5	—	72.3	46.2	30.2	22.1	1100
	SSM6J412TU	-20	±8	-4.0	—	99.6	67.8	51.4	42.7	840
UFM	SSM3J132TU	-12	±6	-5.4	94	39	29	21	17	2700
	SSM3J130TU	-20	±8	-4.4	—	63.2	41.1	31	25.8	1800
	SSM3J133TU	-20	±8	-5.5	—	88.4	56	39.7	29.8	840
ES6	SSM6J212FE	-20	±8	-4.0	—	94.0	65.4	49.0	40.7	970
	SSM6J214FE	-30	±12	-3.6	—	—	149.6	77.6	57	560

MOSFETs in Ultra-Small Packages: Page 6-

New Lineup for 1- to 3-Gate Logic (L-MOS) in MP8 (SOT-902) 8-pin small package. TC7WGxxL8X (LVP Series), TC7WZxxL8X (SHS Series)

MP8 (SOT-902) 8-pin small package with 0.5-mm lead pitch

Toshiba has developed the MP8 (SOT-902) package ideal for high-density board assembly. The LVP and SHS Series will be available in this new package. The LVP Series is popular for battery-powered (low-voltage) applications, while the SHS Series is suitable for a broad range of applications due to its wide operating range.

Applications

Cell phones, portable audio players, PCs, audiovisual equipment, digital still cameras, digital video cameras, etc.

Under development

Functions		TC7WG (LVP) series V _{cc} (opr.) = 0.9 to 3.6 V I _{out} = 8 mA (min) at V _{cc} = 3 V	TC7WZ (SHS) series V _{cc} (opr.) = 1.65 to 5.5 V I _{out} = 24 mA (min) at V _{cc} = 3 V
NAND	00	TC7WG00L8X	TC7WZ00L8X
NOR	02	TC7WG02L8X	TC7WZ02L8X
Inverter	04	TC7WG04L8X	TC7WZ04L8X
Inverter (Unbuffered)	U04	TC7WGU04L8X	TC7WZU04L8X
Inverter (Open-drain)	05	TC7WG05L8X	TC7WZ05L8X
Non-Inverter (Open-drain)	07	TC7WG07L8X	TC7WZ07L8X
AND	08	TC7WG08L8X	TC7WZ08L8X
Schmitt Inverter	14	TC7WG14L8X	TC7WZ14L8X
Schmitt Buffer	17	TC7WG17L8X	TC7WZ17L8X
OR	32	TC7WG32L8X	TC7WZ32L8X
Non-Inverter	34	TC7WG34L8X	TC7WZ34L8X
D-type Flip-Flop	74	TC7WG74L8X	TC7WZ74L8X
Exclusive-OR	86	TC7WG86L8X	TC7WZ86L8X
3-State Buffer	125	TC7WG125L8X	TC7WZ125L8X
3-State Buffer	126	TC7WG126L8X	TC7WZ126L8X

Package Dimensions

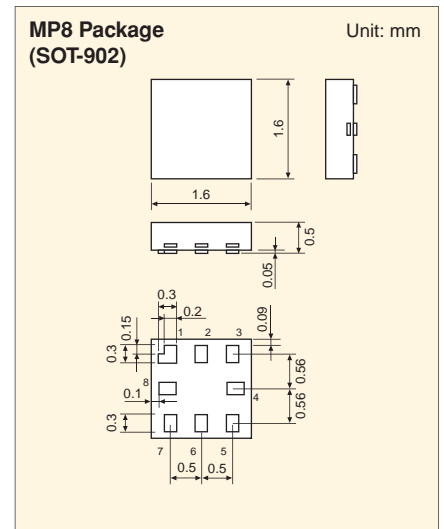

L-MOS: Page 14-

200-mA CMOS LDO Regulators in a Ultra-Small Package (Single-Output) TCR4SxxWBG and TCR4SxxDWBG Series

New Product

CMOS LDO regulators are now available in the WCSP4 ultra-small package

The WCSP4 package occupies only 0.63 mm² of board area and is thus ideal for applications that require high-density board assembly. The CMOS LDO regulators in the WCSP4 package are available with a fixed output voltage between 1.2 V and 3.6 V. The output voltage is able to fix in steps of 50 mV.

The TCR4SxxDWBG Series provides an auto-discharge function, which makes it ideal for applications with complex timing control.

Applications

Cell phones, digital still cameras, portable audio players and other compact portable equipment

Features

- High ripple rejection: R.R = 80 dB (typ.) at I_{OUT} = 10 mA, f = 1 kHz
- Low noise voltage: V_{NO} = 30 μVrms (typ.) at 2.5-V output, I_{OUT} = 10 mA, 10 Hz ≤ f ≤ 100 kHz
- Allows the use of ceramic capacitors (C_{IN} = 0.1 μF, C_{OUT} = 1.0 μF)
- Ultra-small package: WCSP4 (0.79 x 0.79 x 0.50 mm)

Part Number	V _{OUT} (V)	Control pin Connection	Auto Discharge
TCR4S15WBG	1.5	Open	No
TCR4S18WBG	1.8		
TCR4S28WBG	2.8		
TCR4S30WBG	3.0		
TCR4S12DWBG	1.2	Pull-down	Yes
TCR4S15DWBG	1.5		
TCR4S18DWBG	1.8		
TCR4S20DWBG	2.0		
TCR4S21DWBG	2.1		
TCR4S25DWBG	2.5		
TCR4S26DWBG	2.6		
TCR4S27DWBG	2.7		
TCR4S28DWBG	2.8		
TCR4S285DWBG	2.85		
TCR4S29DWBG	2.9		
TCR4S295DWBG	2.95		
TCR4S30DWBG	3.0		
TCR4S33DWBG	3.3		

Package Dimensions

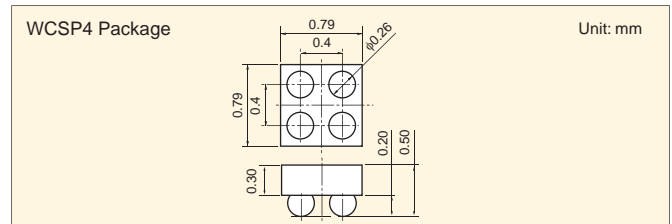

Auto-Discharge Function (Example shown for a 1.5-V LDO regulator)

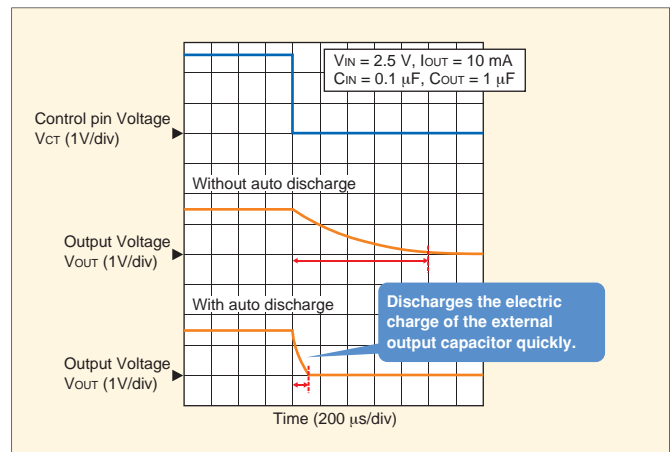

LDOs: Page 28-

Digital-Output Magnetic Sensors TCS20DPC, TCS20DLC

Available in the 0.38-mm ultra-thin, small CST6C package

The TCS20DPC and TCS20DLC are digital-output magnetic sensors. These digital-output magnetic sensors are ideal for applications with open/close or sliding mechanisms, such as cell phones, notebook PCs and digital still cameras. The new digital-output magnetic sensors are much thinner and smaller than their predecessors and thus save board space.

Applications

Cell phones, notebook PCs, digital still cameras, etc.

Features

- Ultra-thin, small package with a thickness of 0.38 mm (CST6C: 1.5 mm x 1.15 mm x 0.38 mm)
- South-Pole and North-Pole detections (Double detections)
- Magnetic flux density (I_{BON1} = 3.8 mT (max), I_{BOFF1} = 0.3 mT (min))
- Push-pull output (TCS20DPC) and open-drain output (TCS20DLC)
- Low quiescent-bias current (Average current I_{CC} = 12.8 μA at V_{CC} = 3.3 V)
- Extended operating voltage range (V_{CC} = 2.3 to 3.6 V)

Part Number	Output Configuration
TCS20DPC	Push-Pull
TCS20DLC	Open-Drain

Package Dimensions

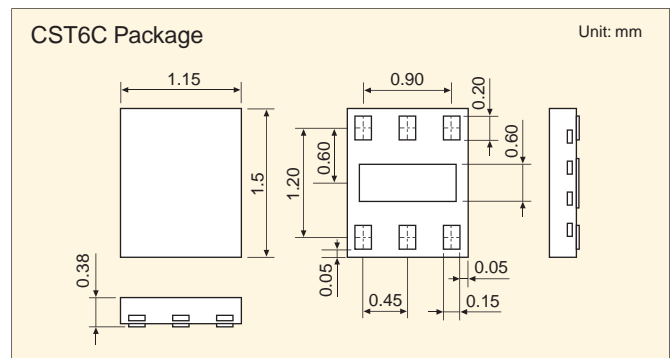

Digital-Output Magnetic Sensors: Page 34-

520 and 521 Small-Signal Schottky Barrier Diode (SBD) Series (CES520/521, CTS520/521, CUS520/521)

Low- V_F and low- I_R SBDs fabricated with a new process

Toshiba has developed, using a new process, small-signal Schottky barrier diodes (SBDs). Included among our latest products are low- V_F and low- I_R SBDs. These SBDs are available in three new packages: ESC, USC and CST2. They are ideally suited for battery-powered applications that require reduced power consumption. They can also be used as replacements for competitors' devices.

■ Applications

Current reversal prevention, low-voltage rectification, high-efficiency DC-DC converters, IC protection
 • Cell phones • Digital still cameras • Game consoles • PC peripherals

■ Electrical Characteristics

	Characteristic	Symbol	Test Conditions	Min	Typ.	Max	Unit
520 Series	Forward Voltage	V_F	$I_F = 200 \text{ mA}$	–	0.52	0.6	V
	Reverse Current	I_R	$V_R = 30 \text{ V}$	–	–	5	μA
	Total Capacitance	C_T	$V_R = 0, f = 1 \text{ MHz}$	–	17	–	pF
521 Series	Forward Voltage	V_F	$I_F = 200 \text{ mA}$	–	0.45	0.5	V
	Reverse Current	I_R	$V_R = 30 \text{ V}$	–	–	30	μA
	Total Capacitance	C_T	$V_R = 0, f = 1 \text{ MHz}$	–	26	–	pF

Small-Signal Diodes: Page 42-

Low-Noise CMOS Operational Amplifier TC75S63TU

Toshiba has added the TC75S63TU featuring low equivalent input noise voltage to its CMOS op amp portfolio. Housed in a tiny package, it is ideal for applications that amplify a weak signal from a vibration sensor, etc.

■ Features

- Low equivalent input noise voltage:
7.8 $\text{nV}/\sqrt{\text{Hz}}$ typ. at $V_{DD} = 3.3 \text{ V}$, $f = 1 \text{ kHz}$
- Small phase delay: -2.5 degree typ. at $V_{DD} = 3.3 \text{ V}$, $f = 2 \text{ kHz}$
- Small input bias current: 1 pA typ. at $V_{DD} = 3.3 \text{ V}$
- Small package: UFV ($2.0 \times 2.1 \times 0.7 \text{ mm}$)
- Suitable for the applications such as shocksensors, etc.

■ Equivalent Input Noise Voltage vs. Frequency (at $V_{DD} = 3.3 \text{ V}$, $T_a = 25^\circ\text{C}$)

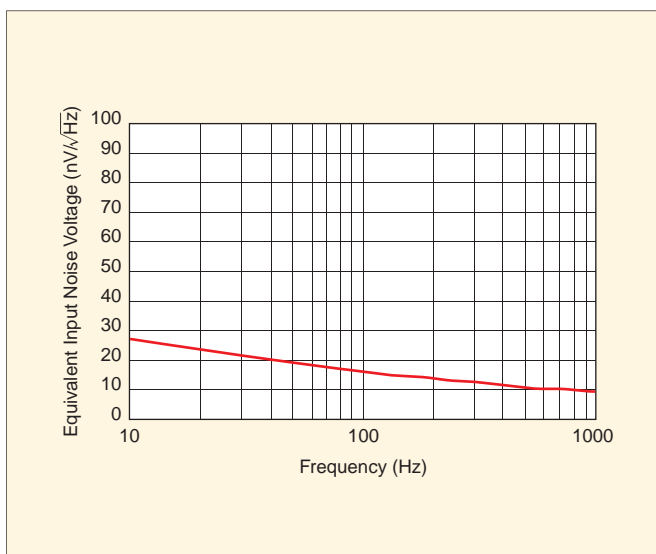

■ Package Dimensions

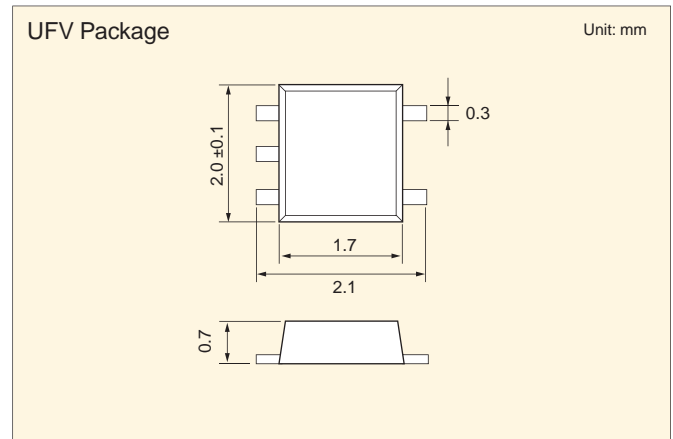

■ Pin Assignments

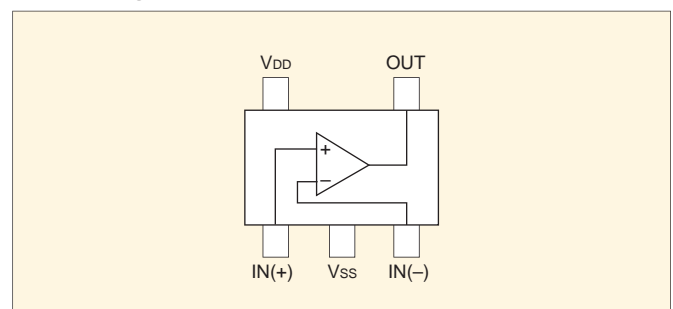

Op Amps & Comparators: Page 38-

2

MOSFETs in Ultra-Small Packages

2.1 New Products: MOSFETs in UDFN6 (2 x 2 mm LGA type) Package

Mobile devices such as cell phones, smartphones and mobile audio players are becoming increasingly sophisticated, resulting in more densely packed boards. This is driving the need for tiny and low-Ron MOSFETs. To address this need, Toshiba has developed MOSFETs housed in an LGA-like UDFN6 package measuring 2 x 2 mm, which provides an excellent die-attach capability.

Applications

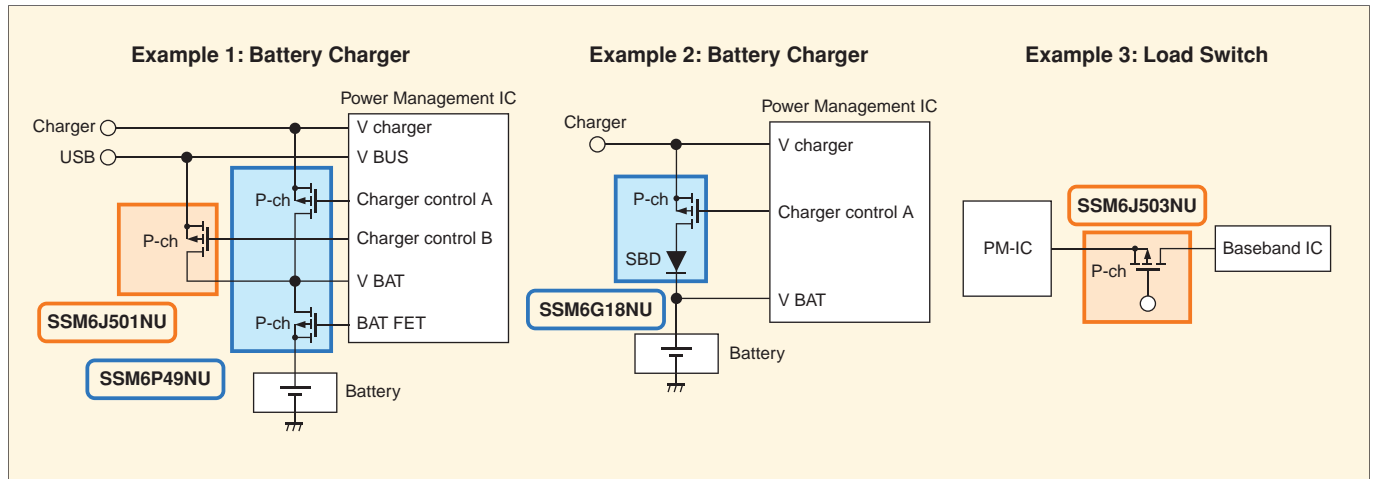

Product Lineup

New Product

Part Number	Polarity	V _{DSS} (V)	V _{GSS} (V)	I _D (A)	R _{ON(max)} (mΩ)				C _{iss} (pF)
					V _{GS} = 1.5 V	V _{GS} = 1.8 V	V _{GS} = 2.5 V	V _{GS} = 4.5 V	
SSM6J501NU	P-ch	-20	±8	-10.0	43	26.5	19	15.3	2600
SSM6J502NU	P-ch	-20	±8	-6.0	60.5	38.4	28.3	23.1	1800
SSM6J503NU	P-ch	-20	±8	-6.0	89.6	57.9	41.7	32.4	840
SSM6P47NU	P-ch + P-ch	-20	±8	-4.0	242	170	125	95	290
SSM6P49NU	P-ch + P-ch	-20	±12	-4.0	-	157	76	56	480

Part Number	Polarity	MOSFET								SBD			
		V _{DSS} (V)	V _{GSS} (V)	I _D (A)	R _{ON(max)} (mΩ)				C _{iss} (pF)	V _R (V)	I _O (A)	V _F (max)	
					V _{GS} = 1.5 V	V _{GS} = 1.8 V	V _{GS} = 2.5 V	V _{GS} = 4.5 V				V _F (V)	I _F (A)
SSM6G18NU	P-ch + SBD	-20	±8	-2	261	185	143	112	270	30	1.0	0.45	0.5

Package Dimensions (Top View)

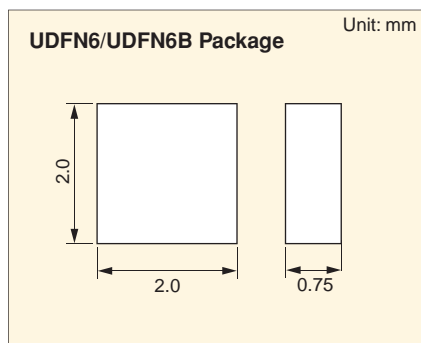

Pin Assignments (Top View)

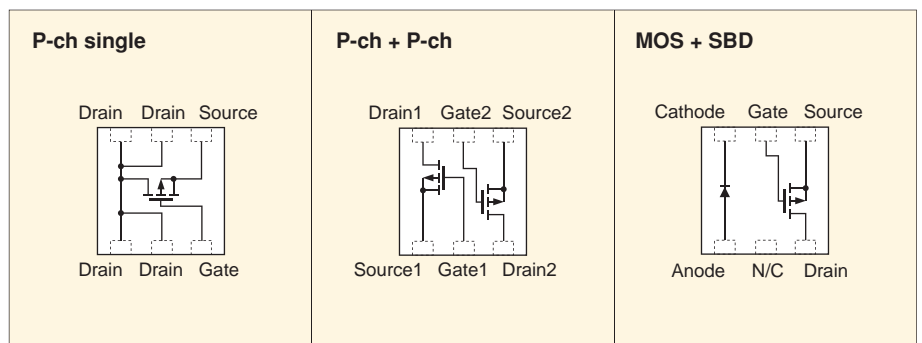

2.2 Roadmap for Toshiba MOSFET Development

Trench Process Roadmap

TOSHIBA original Trench process is W.W top level performance which contribute to ultra low $R_{DS(ON)}$ and voltage performance.

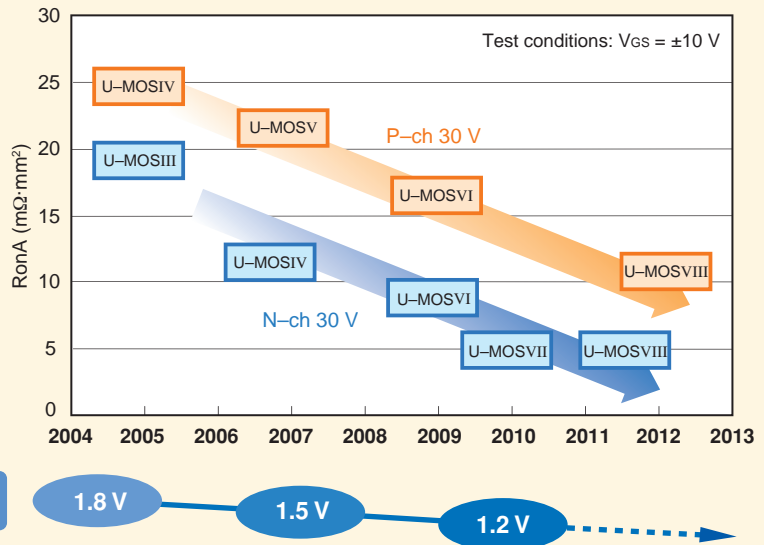

Packaging Lineup

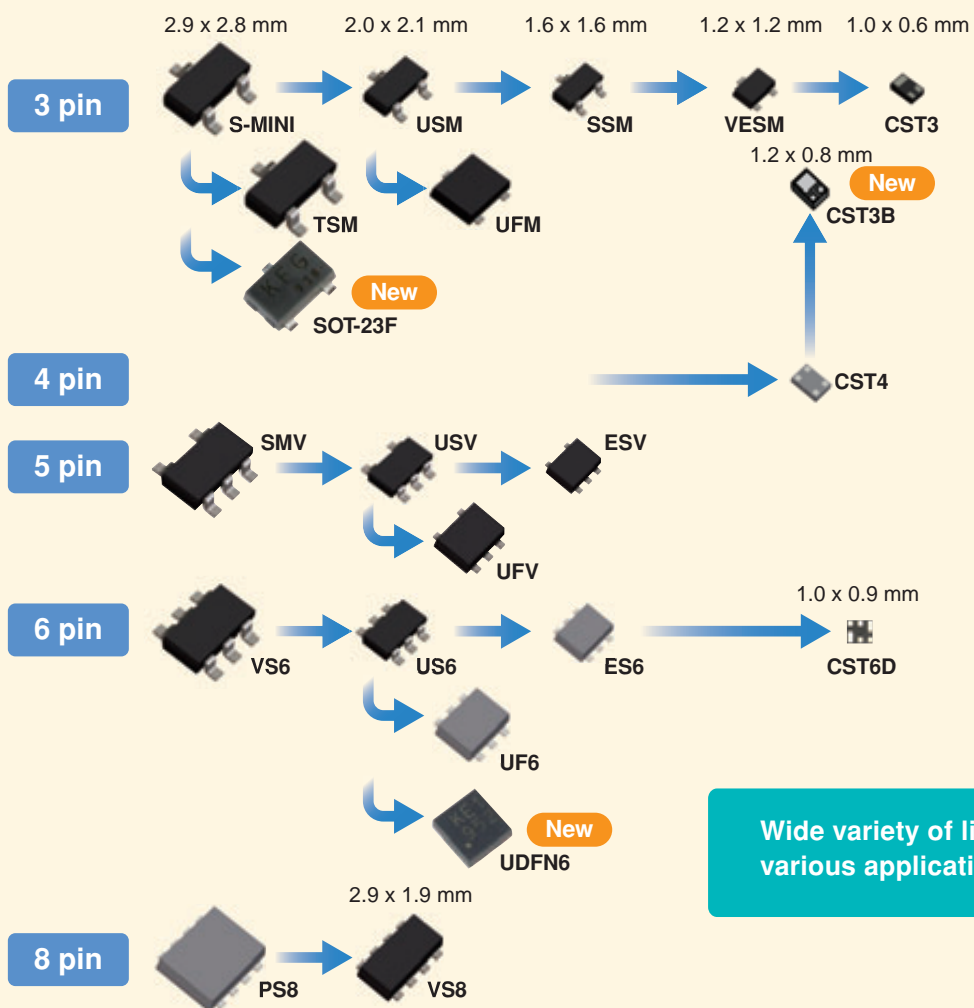

Wide variety of lineup for various applications.

2-3 Application Examples and Block Diagrams

Cell Phone (Power Supply Circuit)

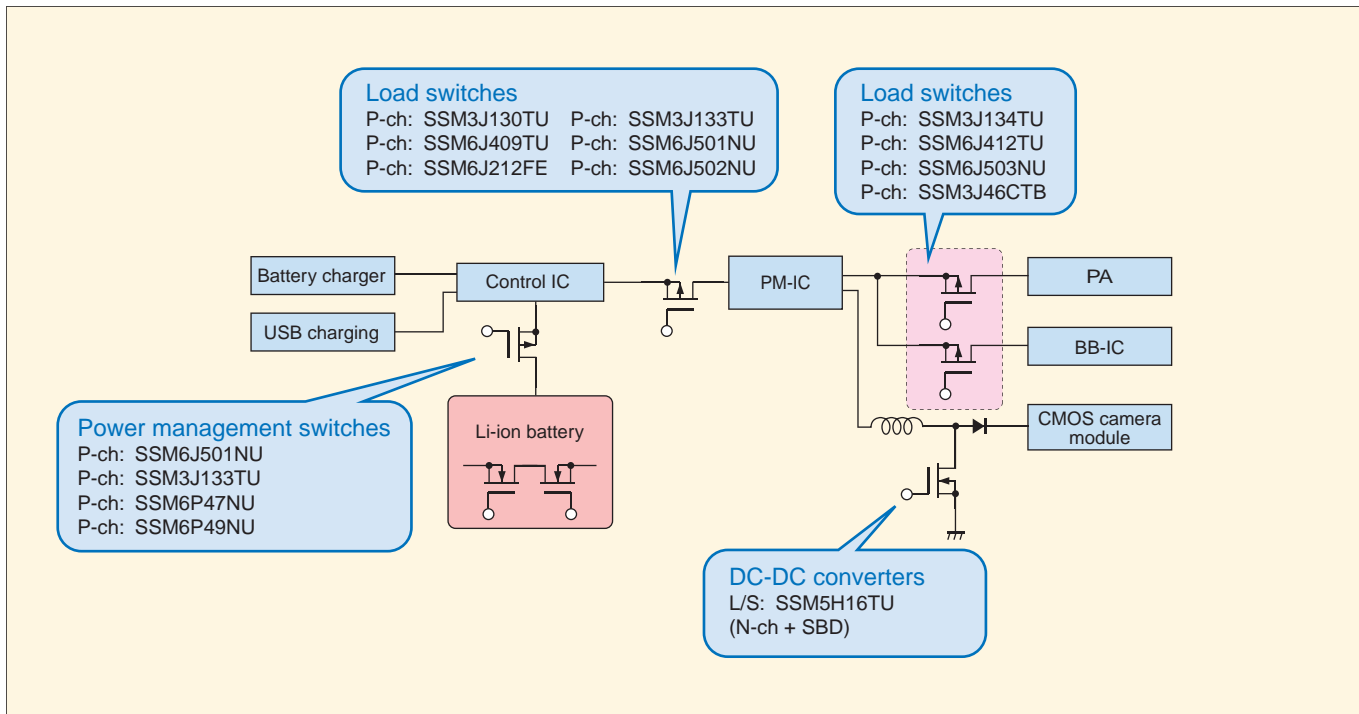



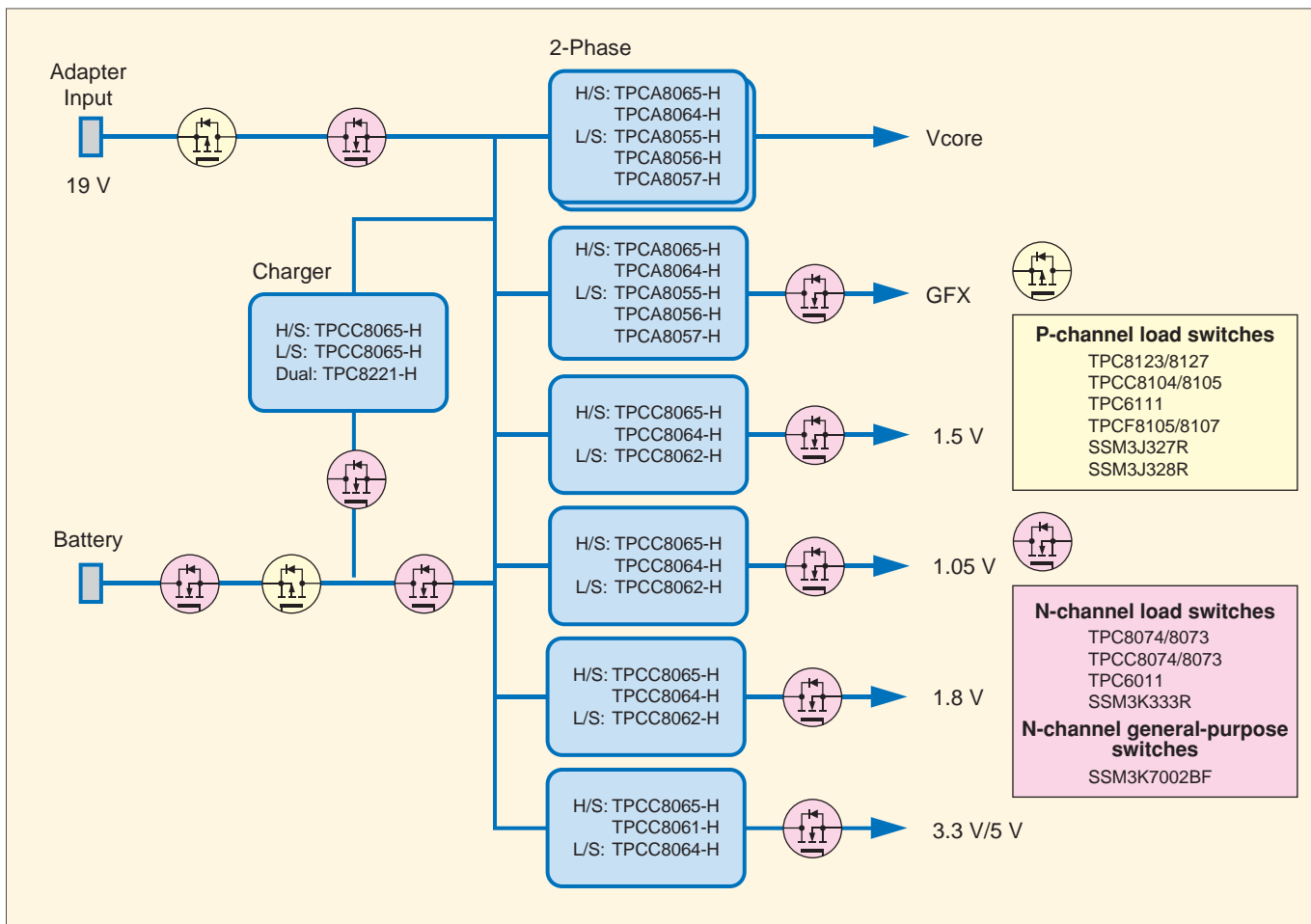







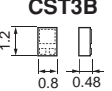
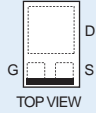
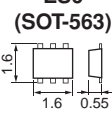
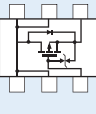
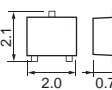

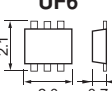
Notebook PC (Power Supply Circuit)

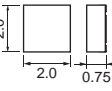

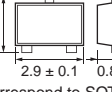
2.4 Over 500 mA Series MOSFET (Semi-Power type)

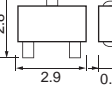
P-Channel Single MOSFET

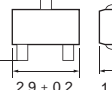
Unit: mm

Package	Part Number	V _{bss} (V)	V _{gss} (V)	I _d (A)	R _{ds(on)} Max (mΩ)					C _{iss} (pF)	Series	*Internal Connections
					I _{Vgs} = 1.2 V	I _{Vgs} = 1.5 V	I _{Vgs} = 1.8 V	I _{Vgs} = 2.5 V	I _{Vgs} = 4.5 V			
CST3B 	SSM3J46CTB	-20	±8	-2.0	—	250	178	133	103	290	U-MOSVI	
ES6 (SOT-563) 	SSM6J212FE	-20	±8	-4.0	—	94.0	65.4	49.0	40.7	970	U-MOSVI	
	SSM6J214FE	-30	±12	-3.6	—	—	149.6	77.6	57	560	U-MOSVI	
	SSM6J213FE	-20	±8	-2.6	—	250	178	133	103	290	U-MOSVI	
	SSM6J207FE	-30	±20	-1.4	—	—	—	—	491(@4V)	137	U-MOSII	
UFM  (Correspond to SOT-323)	SSM3J132TU	-12	±6	-5.4	94	39	29	21	17	2700	U-MOSVI	
	SSM3J130TU	-20	±8	-4.4	—	63.2	41.1	31	25.8	1800	U-MOSVI	
	SSM3J133TU	-20	±8	-5.5	—	88.4	56	39.7	29.8	840	U-MOSVI	
	SSM3J134TU	-20	±8	-3.2	—	240	168	123	93	290	U-MOSVI	
	SSM3J135TU	-20	±8	-3.0	—	260	180	132	103	270	U-MOSVI	
	SSM3J113TU	-20	±12	-1.7	—	—	—	249	169(@4V)	370	U-MOSIII	
	SSM3J111TU	-20	±12	-1.0	—	—	—	680	480(@4V)	160	U-MOSIII	
	SSM3J117TU	-30	±20	-2.0	—	—	—	—	225(@4V)	280	U-MOSII	
	SSM3J118TU	-30	±20	-1.4	—	—	—	—	480(@4V)	137	U-MOSII	
UF6  (Correspond to SOT-363)	SSM6J409TU	-20	±8	-9.5	—	72.3	46.2	30.2	22.1	1100	U-MOSV	
	SSM6J412TU	-20	±8	-4.0	—	99.6	67.8	51.4	42.7	840	U-MOSVI	
	SSM6J50TU	-20	±10	-2.5	—	—	205(@2.0V)	100	64	800	U-MOSIV	
	SSM6J410TU	-30	±20	-2.1	—	—	—	—	393(@4V)	120	U-MOSIII	
	SSM6J401TU	-30	±20	-2.5	—	—	—	—	145(@4V)	730	U-MOSIII	
UDFN6B 	SSM6J501NU	-20	±8	-10	—	43	26.5	19	15.3	2600	U-MOSVI	
	SSM6J502NU	-20	±8	-6.0	—	60.5	38.4	28.3	23.1	1800	U-MOSVI	
	SSM6J503NU	-20	±8	-6.0	—	89.6	57.9	41.7	32.4	840	U-MOSVI	
SOT-23F  (Correspond to SOT-23)	SSM3J328R	-20	±8	-6.0	—	88.4	56.0	39.7	29.8	840	U-MOSVI	
	SSM3J327R	-20	±8	-3.9	—	240	168	123	93	290	U-MOSVI	
	SSM3J332R	-30	±12	-6.0	—	—	144	72	50	560	U-MOSVI	
	SSM3J334R	-30	±20	-4.0	—	—	—	—	105	280	U-MOSVI	
TSM  (Correspond to SOT-23)	SSM3J326T	-30	±12	-5.6	—	—	115	62.5	45.7	650	U-MOSVI	
	SSM3J306T	-30	±20	-2.4	—	—	—	—	225(@4V)	280	U-MOSII	
	SSM3J305T	-30	±20	-1.7	—	—	—	—	477(@4V)	137	U-MOSII	
S-Mini 	SSM3J325F	-20	±8	-2.0	—	311	231	179	150	270	U-MOSVI	

*: The internal connection diagrams only show the general configurations of the circuits.



 New product

2

MOSFETs in Ultra-Small Packages

N-Channel Single MOSFETs

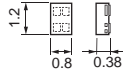
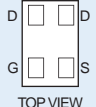
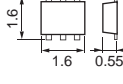
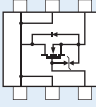
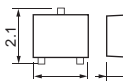
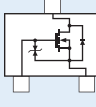
Unit: mm

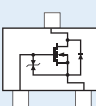
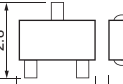
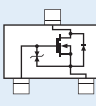
Package	Part Number	V _{DSS} (V)	V _{GSS} (V)	I _D (A)	R _{DS(ON)} Max (mΩ)				C _{iss} (pF)	Series	*Internal Connections		
					I _{VGS} = 1.5 V	I _{VGS} = 1.8 V	I _{VGS} = 2.5 V	I _{VGS} = 4.0 V					
CST4 	SSM4K27CT	20	±12	0.5	—	390	260	205	174	U-MOSIII	 TOP VIEW		
	ES6 (SOT-563) 	SSM6K211FE SSM6K203FE SSM6K202FE SSM6K204FE SSM6K208FE SSM6K210FE SSM6K30FE SSM6K31FE	20	±10	3.2	118	82	59	47(@4.5 V)	510	U-MOSIII		
UFM  (Correspond to SOT-323)	SSM3K123TU SSM3K121TU SSM3K119TU SSM3K122TU SSM3K127TU SSM3K116TU SSM3K131TU * SSM3K124TU SSM3K105TU SSM3K128TU SSM3K107TU SSM3K106TU	20	±10	4.2	66	43	32	28	1010	U-MOSIII			
	SSM6K403TU SSM6K404TU SSM6K405TU SSM6K411TU * SSM6K18TU SSM6K406TU SSM6K34TU SSM6K407TU	20	±10	4.2	66	43	32	28	1050	U-MOSIII			
	SSM6K404TU SSM6K405TU SSM6K411TU * SSM6K18TU SSM6K406TU SSM6K34TU SSM6K407TU	20	±10	3.0	147	100	70	55	400	U-MOSIII			
	SSM6K411TU * SSM6K18TU SSM6K406TU SSM6K34TU SSM6K407TU	20	±12	10	—	—	23.8	12(@4.5 V)	710	U-MOSIV			
	SSM6K18TU SSM6K406TU SSM6K34TU SSM6K407TU	20	±12	4.0	—	—	54	40	1100	U-MOSIII			
	SSM6K406TU SSM6K34TU SSM6K407TU	30	±20	4.4	—	—	—	38.5(@4.5 V)	490	U-MOSIV			
	SSM6K34TU SSM6K407TU	30	±20	3.0	—	—	—	77(@4.5 V)	470	U-MOSIII			
	SSM6K407TU	60	±20	2.0	—	—	—	440	150	π-MOSV			
	SOT-23F  (Correspond to SOT-23)	SSM3K329R	30	±12	3.5	—	289	170	126	123		U-MOSIII	
		SSM3K333R *	30	±20	6.0	—	—	—	42 (@4.5 V)	436		U-MOSVII-H	
	TSM  (Correspond to SOT-23)	SSM3K310T	20	±10	5.0	66	43	32	28	1120		U-MOSIII	
		SSM3K309T	20	±12	4.7	—	47	35	31	1020		U-MOSIII	
		SSM3K301T	20	±12	3.5	—	110	74	56	320		U-MOSIII	
		SSM3K316T	30	±12	4.0	—	131	87	65(@4.5 V)	270		U-MOSIII	
SSM3K320T *		30	±20	4.2	—	—	—	77(@4.5 V)	190	U-MOSIV			
SSM3K318T	60	±20	2.5	—	—	—	145(@4.5 V)	235	U-MOSIV				

*: Without protection Zener diode between gate and source *: The internal connection diagrams only show the general configurations of the circuits.

 New product

Dual MOSFETs

Unit: mm

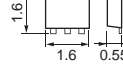
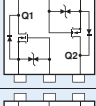
Package	Polarity	Part Number	V _{DSS} (V)	V _{GSS} (V)	I _D (A)	R _{DS(ON)} Max (mΩ)				C _{iss} (pF)	Series	*Internal Connections
						I _{VGS} = 1.5 V	I _{VGS} = 1.8 V	I _{VGS} = 2.5 V	I _{VGS} = 4.5 V			
ES6 (SOT-563) 	N-ch x 2	SSM6N42FE	20	±10	0.8	600	450	330	240	90	U-MOSIII	
	P-ch x 2	SSM6P41FE	-20	±8	-0.72	1040	670	440	300	110	U-MOSV	
	N-ch + P-ch	SSM6L14FE	20	±10	0.8	600	450	330	240	90	U-MOSIII	
			-20	±8	-0.72	1040	670	440	300	110	U-MOSV	

*: The internal connection diagrams only show the general configurations of the circuits.



 New product

Dual MOSFETs (Continued)

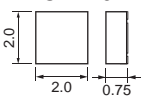
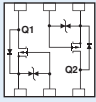
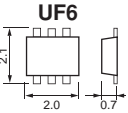
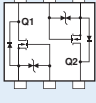
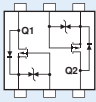
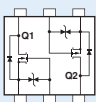
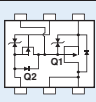
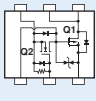
Unit: mm

Package	Polarity	Part Number	V _{DSS} (V)	V _{CESS} (V)	I _D (A)	R _{DS(ON)} Max (mΩ)				C _{iss} (pF)	Series	*Internal Connections
						I _{VGS1} = 1.5V	I _{VGS1} = 1.8V	I _{VGS1} = 2.5V	I _{VGS1} = 4.0V			
 UDFN6	P-ch x 2	SSM6P47NU	-20	±8	-4	242	170	125	95 (@4.5V)	290	U-MOSVI	
		SSM6P49NU	-20	±12	-4	—	157	76	56 (@4.5V)	480	U-MOSVI	
	N-ch x 2	SSM6N55NU	30	±20	4	—	—	—	64 (@4.5V)	570	U-MOSVII-H	
 UF6	N-ch x 2	SSM6N39TU	20	±10	1.6	247	190	139	119	260	U-MOSIII	
		SSM6N24TU	30	±12	0.5	—	—	180	145 (@4.5V)	245	U-MOSIII	
		SSM6N40TU	30	±20	1.6	—	—	—	182	180	U-MOSIII	
	P-ch x 2	SSM6P54TU	-20	±8	-1.2	555	350	228	—	331	U-MOSIV	
		SSM6P39TU	-20	±8	-1.5	—	430	294	213	250	U-MOSIII	
		SSM6P25TU	-20	±12	-0.5	—	—	430	260	218	U-MOSIII	
	N-ch + P-ch	SSM6L39TU	20	±10	1.6	247	190	139	119	260	U-MOSIII	
			-20	±8	-1.5	—	430	294	213	250	U-MOSIII	
		30	±12	0.5	—	—	180	145(@4.5V)	245	U-MOSIII		
		-20	±12	-0.5	—	—	430	260	218	U-MOSIII		
	P-ch + N-ch (Load Switch)	SSM6L40TU	30	±20	1.6	—	—	—	182	180	U-MOSIII	
			-30	±20	-1.4	—	—	—	403	120	U-MOSIII	
		SSM6E01TU	-12	±12	-1.0	—	—	240	160	310	U-MOSIII	
		20	10	0.05	—	—	10 Ω	—	11	π-MOSVI		
SSM6E02TU	-20	±8	-1.8	364	204	136	—	568	U-MOSIV			
	20	±10	0.1	15 Ω	—	4 Ω	3 Ω	9.3	π-MOSVI			
	-20	±8	-1.8	—	335	180	144	335	U-MOSIII			
SSM6E03TU	20	±10	0.1	15 Ω	—	4 Ω	3 Ω	9.3	π-MOSVI			

*: The internal connection diagrams only show the general configurations of the circuits.

 New product  Under development

MOSFET with a Schottky Barrier Diode

Unit: mm

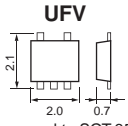
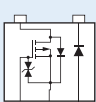
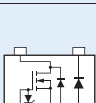
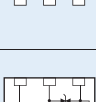
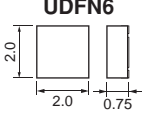
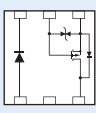
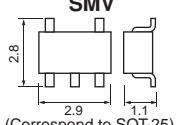
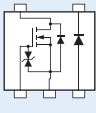
Package	Polarity	Part Number	V _{DSS} (V)	V _{CESS} (V)	I _D (A)	MOSFET				C _{iss} (pF)	Series	SBD			*Internal Connections	
						I _{VGS1} = 1.5V	I _{VGS1} = 1.8V	I _{VGS1} = 2.5V	I _{VGS1} = 4.0V			V _R (V)	I _O (A)	V _F Max (V) @I _F (A)		
 UFV (Correspond to SOT-353)	P-ch+ SBD	SSM5G09TU	-12	±8	-1.5	—	—	200	130	550	U-MOSII	12	0.5	0.43	0.5	
		SSM5G02TU	-12	±12	-1.0	—	—	240	160	310	U-MOSII	12	0.5	0.43	0.5	
		SSM5G10TU	-20	±8	-1.5	—	430	294	213	250	U-MOSIII	20	0.7	0.39	0.5	
		SSM5G04TU	-12	±12	-1.0	—	—	420	240	170	U-MOSII	12	0.5	0.43	0.5	
	N-ch+ SBD	SSM5G11TU	-30	±20	-1.4	—	—	—	403	120	U-MOSIII-H	30	0.7	0.41	0.5	
		SSM5H10TU	20	±10	1.6	247	190	139	119	260	U-MOSIII	20	0.7	0.39	0.5	
		SSM5H16TU	30	±12	1.9	—	296	177	133	123	U-MOSIII	30	0.8	0.45	0.5	
		SSM5H08TU	20	±12	1.5	—	—	220	160	125	U-MOSIII	20	0.5	0.45	0.3	
SSM5H11TU	30	±20	1.6	—	—	—	182	180	U-MOSIII	30	0.7	0.41	0.5			
	SSM5H01TU	30	±20	1.4	—	—	—	450	106	U-MOSII	20	0.5	0.45		0.3	
	SSM5H07TU	20	±20	1.2	—	—	—	540	36	π-MOSVII	12	0.5	0.43		0.5	
 UDFN6	P-ch+ SBD	SSM6G18NU	-20	±8	-2.0	261	185	143	112 (@4.5V)	270	U-MOSVI	30	1.0	0.45	0.5	
 SMV (Correspond to SOT-25)	N-ch+ SBD	SSM5H14F	30	±12	3.0	—	138	94	78	270	U-MOSIII	45	0.1	0.6	0.1	

*: The internal connection diagrams only show the general configurations of the circuits.

 New product

■ VS-8 Series ... [Part Number: TPCF8xxx]

■ Features

- Ultra-low ON-resistance achieved by employing the U-MOS process
- Thin package, with a board mounting height as low as 0.85 mm (max)
- 32% reduction in mounting area compared with the VS-6 (TSOP-6) Series, due to the use of a high-density flat package
- $P_D = 2.5$ W at $t = 5$ s when the device is mounted on a glass epoxy board

■ Product Lineup

Circuit Configuration	Part Number	Absolute Maximum Ratings			$R_{DS(ON)}$ Max (m Ω)						Q_g Typ. (nC)	C_{iss} Typ. (pF)	Marking	Series	
		V_{DS} (V)	V_{GS} (V)	I_D (A)	$I_{VGS1} = 10$ V	$I_{VGS1} = 4.5$ V	$I_{VGS1} = 4$ V	$I_{VGS1} = 2.5$ V	$I_{VGS1} = 2.0$ V	$I_{VGS1} = 1.8$ V					
N-ch	Single	TPCF8003	20	± 12	7	—	18	—	34	—	—	9.5	500	F2C	U-MOSIV
		TPCF8004	30	± 20	7	24	30	—	—	—	—	9	610	F2D	U-MOSVII
N-ch	Dual	TPCF8002	30	± 20	7	21	32	—	—	—	—	11.5	500	F2B	U-MOSIV
		TPCF8201 #	20	± 12	3	—	49	—	66	100	—	7.5	590	F4A	U-MOSIII
P-ch	Single	TPCF8101 #	-12	± 8	-6	—	28	—	40	—	85	18	1600	F3A	U-MOSIII
		TPCF8103 #	-20	± 8	-2.7	—	110	—	160	—	300	6	470	F3C	U-MOSIII
		TPCF8105	-20	± 12	-6	—	30	—	41	—	100	17	1100	F3E	U-MOSVI
	Dual	TPCF8108	-20	± 12	-7	—	26	—	37	—	95	19	1320	F3H	U-MOSVI
		TPCF8107	-30	-25/+20	-6	28	38	—	—	—	—	22	970	F3G	U-MOSVI
		TPCF8301 #	-20	± 8	-2.7	—	110	—	160	—	300	6	470	F5A	U-MOSIII
Dual	TPCF8305	-20	± 12	-4	—	58	—	83	—	265	9.2	680	F5E	U-MOSVI	
	TPCF8304 #	-30	± 20	-3.2	72	105	—	—	—	—	14	600	F5D	U-MOSIV	
	N-ch + P-ch Complementary	TPCF8402 #	30	± 20	4	50	77	—	—	—	—	10	470	F6B	U-MOSIII
-30			± 20	-3.2	72	105	—	—	—	—	14	600	F6B	U-MOSIV	
P-ch + SBD	TPCF8B01 #	-20	± 8	-2.7	—	110	—	160	—	300	6	470	F8A	U-MOSIII	

#: With protection Zener diode between gate and source



■ PS-8 Series ... [Part Number: TPCP8xxx]

■ Features

- Same mounting area as for the VS-6 (TSOP-6) Series
- Flat-leaded package and state-of-the-art process

■ Product Lineup

Circuit Configuration	Part Number	Absolute Maximum Ratings			$R_{DS(ON)}$ Max (m Ω)						Q_g Typ. (nC)	C_{iss} Typ. (pF)	Series	
		V_{DS} (V)	V_{GS} (V)	I_D (A)	$I_{VGS1} = 10$ V	$I_{VGS1} = 4.5$ V	$I_{VGS1} = 4$ V	$I_{VGS1} = 2.5$ V	$I_{VGS1} = 2.0$ V	$I_{VGS1} = 1.8$ V				
N-ch	Single	TPCP8006	20	± 12	9.1	—	10	—	13.7	—	—	22	1480	U-MOSIV
		TPCP8008-H	30	± 20	8	20	23	—	—	—	—	8	900	U-MOSVI-H
		TPCP8004	30	± 20	8.3	8.5	14	—	—	—	—	26	1270	U-MOSIV
		TPCP8005-H	30	± 20	11	12.9	15.7	—	—	—	—	11	1433	U-MOSV-H
		TPCP8007-H	60	± 20	5	57	64	—	—	—	—	5.8	640	U-MOSVI-H
		TPCP8003-H #	100	± 20	2.2	180	190	—	—	—	—	4.5	360	U-MOSIII-H
N-ch	Dual	TPCP8204	30	± 20	4.2	50	77	—	—	—	—	4.6	190	U-MOSIV
		TPCP8205-H	30	± 20	6.5	26	29	—	—	—	—	14	830	U-MOSVI
		TPCP8203 #	40	± 20	4.7	40	60	—	—	—	—	16	770	U-MOSIII
P-ch	Single	TPCP8105	-20	± 12	-5.2	—	17	—	23	45	—	28	2280	U-MOSVI
		TPCP8102 #	-20	± 12	-7.3	—	18	—	30	—	—	33	2560	U-MOSIV
		TPCP8106	-30	-25/+20	-7.2	33	44	—	—	—	—	11.3	870	U-MOSVI
	Dual	TPCP8103-H #	-40	± 20	-4.8	40	54	—	—	—	—	19	800	U-MOSIII-H
		TPCP8303 #	-20	± 8	-3.8	—	46	—	60	—	90	10	640	U-MOSV
		TPCP8305	-20	± 12	-6	—	30	—	42	—	—	21.5	1500	U-MOSVI
N-ch + P-ch Complementary	TPCP8404	30	± 20	4	50	100	—	—	—	—	4.6	190	U-MOSIV	
		-30	± 20	-4	50	100	—	—	—	—	13	510	U-MOSV	
	TPCP8405	30	± 20	6.5	26	29	—	—	—	—	13.8	830	U-MOSVI-H	
		-30	± 20	-6	31.3	42	—	—	—	—	24.1	1075	U-MOSVI	
TPCP8406	40	± 20	6	32	36	—	—	—	—	13.7	850	U-MOSVI-H		
	-40	± 20	-5	43.2	53.4	—	—	—	—	24.2	1105	U-MOSVI		

#: With protection Zener diode between gate and source



2.5

Under 500 mA Series MOSFET (Standard type)

Single MOSFETs

Polarity	Absolute Maximum Ratings				R _{DS(ON)} Typ. (Max) (Ω)	V _{GS} (V)	Package					
	V _{DSS} (V)	V _{GSS} (V)	I _D (mA)	S-Mini (SOT-346) 2925 size, 3-pin			USM (SOT-323) 2021 size, 3-pin	UFM 2021 size, 3-pin	SSM (SOT-416) 1616 size, 3-pin	VESM (SOT-723) 1212 size, 3-pin	CST3 1006 size, 3-pin	
N-ch	20	±10	180	5 (20)	1.2	—	—	—	SSM3K35FS	SSM3K35MFV	SSM3K35CT	
	20	±10	200	3.07(5.6)	1.5	—	—	—	SSM3K37FS	—	SSM3K37CT	
	20	±10	250	3.07(5.6)	1.5	—	—	—	SSM3K37MFV	—	—	
	20	±10	500	0.95 (1.52)	1.5	—	—	SSM3K36TU	SSM3K36FS	SSM3K36MFV	—	
	20	±10	500	0.95 (1.52)	1.5	—	—	—	SSM3K43FS	—	—	
	30	±20	100	4.0 (7.0)	2.5	SSM3K15F	—	—	—	—	—	
	30	±20	100	3.5 (6.0)	2.5	—	SSM3K15AFU	—	SSM3K15AFS	SSM3K15AMFV	SSM3K15ACT	
	30	±20	100	4.0 (7.0)	2.5	—	—	—	SSM3K44FS	SSM3K44MFV	—	
	30	±20	400	0.8 (1.2)	4.0	—	SSM3K09FU	—	—	—	—	
	50	±7	100	22 (40)	2.5	—	SSM3K17FU	—	—	—	—	
P-ch	60	±20	200	1.8 (3.3)	4.5	SSM3K7002AF	SSM3K7002AFU	—	—	—	—	
	60	±20	200	2.1 (3.3)	4.5	SSM3K7002BF	SSM3K7002BFU	—	SSM3K7002BFS	—	—	
	-20	±10	-100	11 (44)	-1.2	—	—	—	SSM3J35FS	SSM3J35MFV	SSM3J35CT	
	-20	±8	-330	2.23 (3.6)	-1.5	—	—	SSM3J36TU	SSM3J36FS	SSM3J36MFV	—	
	-30	±20	-100	14 (32)	-2.5	SSM3J15F	SSM3J15FU	—	SSM3J15FS	SSM3J15FV	—	
	-30	±20	-200	3.3 (4.2)	-4.0	—	SSM3J09FU	—	—	—	—	
	-60	±20	-200	1.3 (2.0)	-10	2SJ168	—	—	—	—	—	

 New product

Dual MOSFETs

Polarity	Absolute Maximum Ratings				R _{DS(ON)} Typ. (Max) (Ω)	V _{GS} (V)	Package						Constituent Devices
	V _{DSS} (V)	V _{GSS} (V)	I _D (mA)	US6 (SOT-363) 2021 size, 6-pin			UF6 2021 size, 6-pin	USV (SOT-353) 2021 size, 5-pin	ES6 (SOT-563) 1616 size, 6-pin	ESV (SOT-553) 1616 size, 5-pin	CST6D 1009 size, 6-pin		
N-chx2	20	±10	180	5 (20)	1.2	SSM6N35FU	—	—	SSM6N35FE	—	—	SSM3K35FSx2	
	20	±10	100	5.2 (15)	1.5	—	—	SSM5N16FU	—	SSM5N16FE	—	SSM3K16FUx2	
	20	±10	250	3.07 (5.6)	1.5	—	SSM6N37FU	—	SSM6N37FE	—	SSM6N37CTD	SSM3K37MFVx2	
	20	±10	500	0.95 (1.52)	1.5	—	SSM6N36TU	—	SSM6N36FE	—	—	SSM3K36FSx2	
	20	±10	500	0.95 (1.52)	1.5	SSM6N43FU	—	—	—	—	—	SSM3K43FSx2	
	30	±20	100	3.5 (6.0)	2.5	SSM6N15AFU	—	—	SSM6N15AFE	—	—	SSM3K15AFUx2	
	30	±20	100	4.0 (7.0)	2.5	SSM6N44FU	—	—	SSM6N44FE	—	—	SSM3K44FSx2	
	30	±20	100	4.0 (7.0)	2.5	—	—	SSM5N15FU	—	SSM5N15FE	—	SSM3K15FUx2	
	30	±20	400	0.8 (1.2)	4.0	SSM6N09FU	—	—	—	—	—	SSM3K09FUx2	
	50	±7	100	22 (40)	2.5	SSM6N17FU	—	—	—	—	—	SSM3K17FUx2	
P-chx2	60	±20	200	1.8 (3.3)	4.5	SSM6N7002AFU	—	—	—	—	—	SSM3K7002AFUx2	
	60	±20	200	2.1 (3.3)	4.5	SSM6N7002BFU	—	—	SSM6N7002BFE	—	—	SSM3K7002BFUx2	
	-20	±10	-100	11 (44)	-1.2	SSM6P35FU	—	—	SSM6P35FE	—	—	SSM3J35FSx2	
	-20	±10	-100	18 (45)	-1.5	SSM6P16FU	—	SSM5P16FU	SSM6P16FE	SSM5P16FE	—	SSM3J16FUx2	
	-20	±8	-330	2.23 (3.6)	-1.5	—	SSM6P36TU	—	SSM6P36FE	—	—	SSM3J36FSx2	
N-ch+ P-ch	-30	±20	-100	14 (32)	-2.5	SSM6P15FU	—	SSM5P15FU	SSM6P15FE	SSM5P15FE	—	SSM3J15FUx2	
	-30	±20	-200	3.3 (4.2)	-4.0	SSM6P09FU	—	—	—	—	—	SSM3J09FUx2	
	20	±10	180	5 (20)	1.2	SSM6L35FU	—	—	SSM6L35FE	—	—	SSM3K35FS +SSM3J35FS	
	20	±10	500	0.95 (1.52)	1.5	—	SSM6L36TU	—	SSM6L36FE	—	—	SSM3K36FS +SSM3J36FS	
	30	±20	400	0.8 (1.2)	4.0	SSM6L09FU	—	—	—	—	—	SSM3K09FU +SSM3J09FU	

 New product

3

L-MOS (1- to 3-Gate Logic ICs)

3.1

Outlines of L-MOS

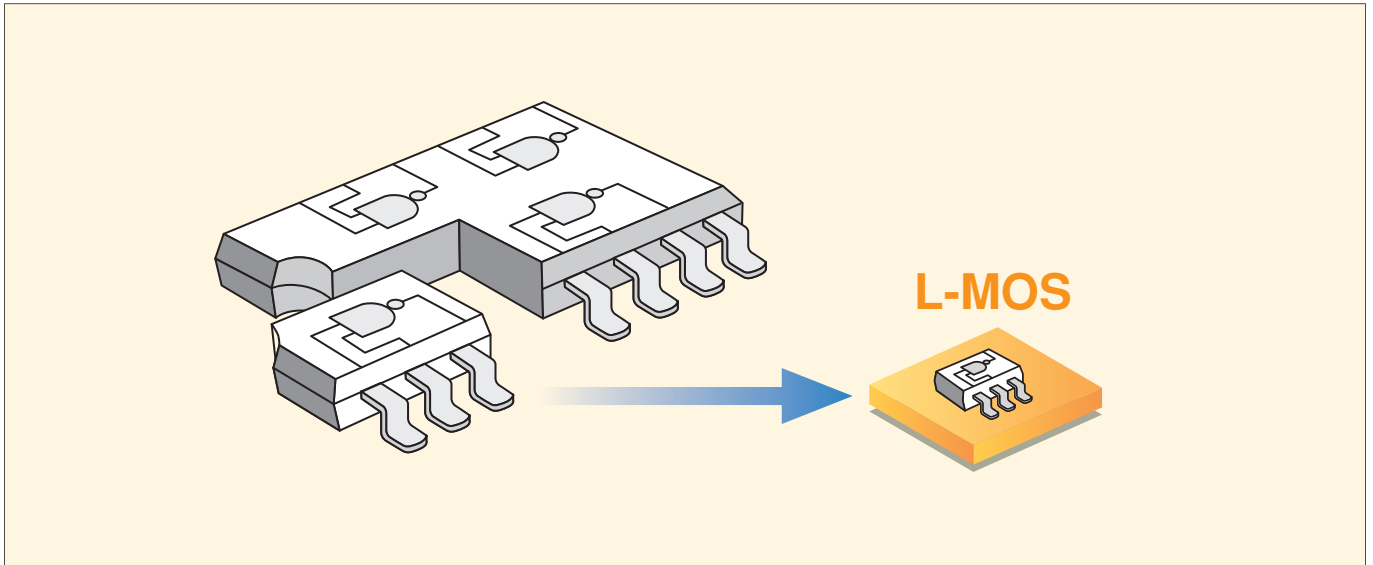

Packaging Features

1. Ultra-small, thin packages

Many L-MOS ICs are available in ultra-small, thin packages such as 5-pin fSV (SOT-953) (measuring 1.0 mm × 1.0 mm × 0.48 mm) and CST8 (measuring 1.45 mm × 1.35 mm × 0.38 mm).

2. General packages

L-MOS ICs are also available in various industry-standard packages for ease of use:

ESV (SOT-553), USV (SOT-353), SMV (SOT-25), ES6 (SOT-563), US6 (SOT-363), MP8 (SOT-902), US8 (SOT-765), SM8 (SOT-505)

3. Product series and function lineups

Toshiba offers a wide range of functions as well as product series that meet various supply voltage requirements.

Product Lineup

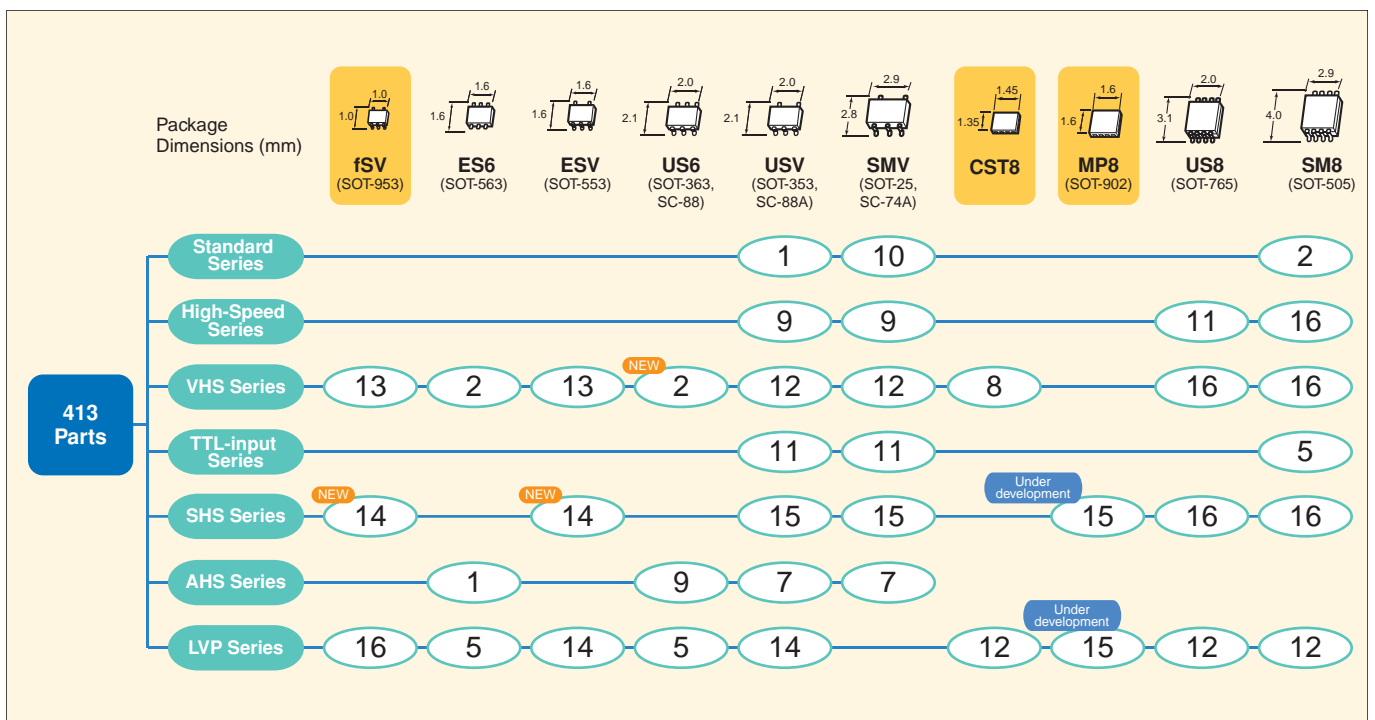

3.2 New Product Information

LVP Series

Low-Voltage, Low-Power-Consumption LVP Series:

**TC7SGxxAFS/TC7SGxxFE/TC7SGxxFU/TC7PGxxAFE/TC7PGxxFU/TC7WGxxFC/
TC7WGxxFK/TC7WGxxFU/TC7WGxxL8X**

■ Features

- Low operating voltage range: 0.9 V to 3.6 V
- 5.5-V tolerant inputs and 3.6-V* power down protection outputs.
- Ultra-small, thin packages: fSV (SOT-953), CST8, MP8 (SOT-902) (The LVP devices are also available in USV (SOT-353), ESV (SOT-553), US8 (SOT-765) and SM8 (SOT-505))
- Low power consumption (low power dissipation capacitance):
Cpd = 6 pF at Vcc = 3.6 V
- Propagation delay time: 2.5 ns (typ.) at Vcc = 3.3 V, CL = 15 pF
- High output current: ±8 mA (min) at Vcc = 3.0 V
- Wide range of packages and low switching noise

*The output protection circuit of the TC7SGxxAFS and TC7PGxxAFE Series is different from that of the TC7SGxxFU/FE and TC7WGxxFU/FK/FC/L8X Series; a voltage greater than or equal to Vcc should not be applied to the TC7SGxxAFS and TC7PGxxAFE Series.

■ Operating Voltage and Tolerance Voltage

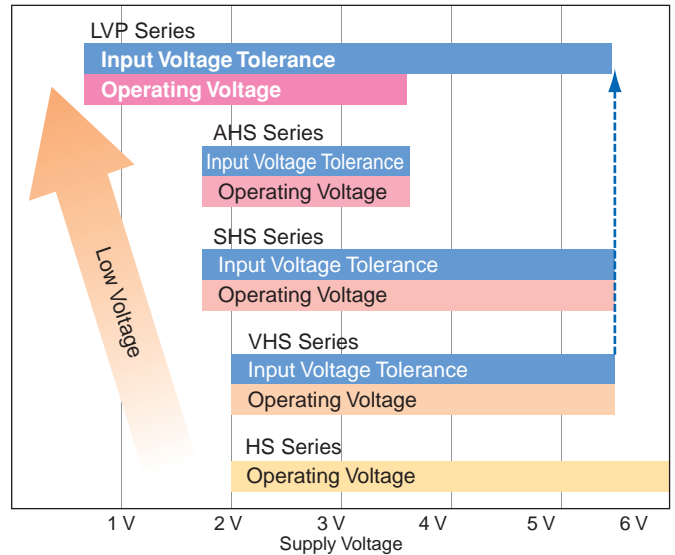

Ultra-Small, Thin fSV, CST8 and MP8 Packages

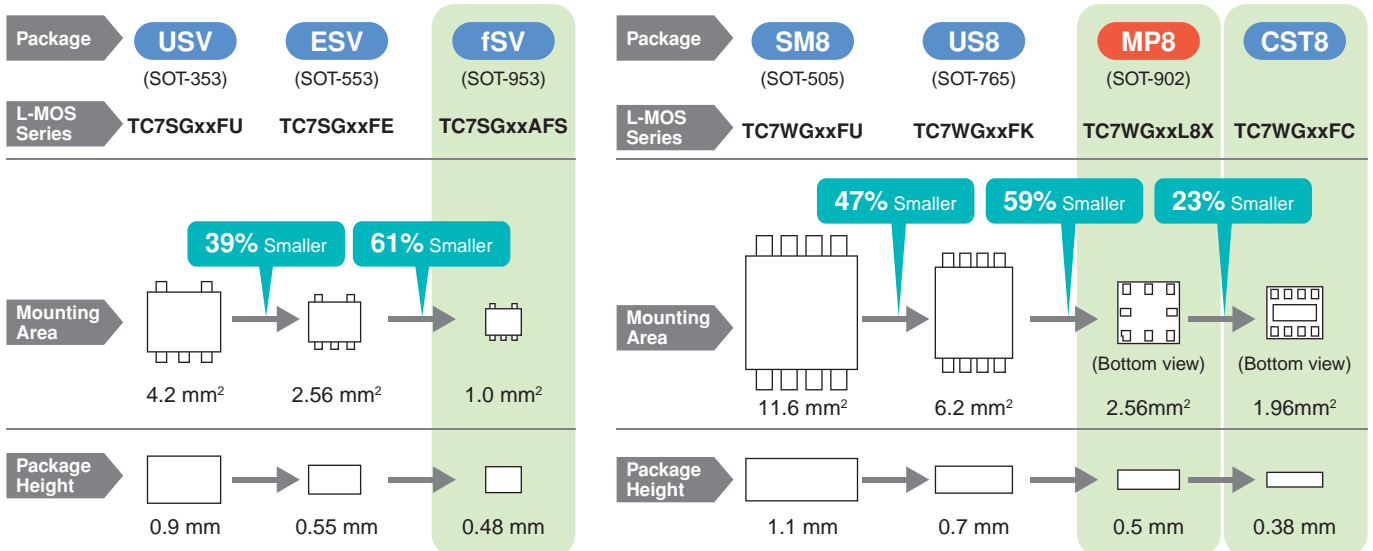

■ fSV (SOT-953)

- Package Dimensions: 1.0 mm x 1.0 mm x 0.48 mm (typ.)
- Lead pitch: 0.35 mm

■ CST8

- Package Dimensions: 1.45 mm x 1.35 mm x 0.38 mm (typ.)
- Lead pitch: 0.40 mm

■ MP8 (SOT-902)

- Package Dimensions: 1.6 mm x 1.6 mm x 0.5 mm (typ.)
- Lead pitch: 0.50 mm

3

L-MOS (1- to 3-Gate Logic ICs)

■ fSV (SOT-953) Package

The LVP (TC7SGxxAFS), VHS (TC7SHxxFS) and SHS (TC7SZxxAFS) Series are available in fSV (SOT-953) package.

■ Package Dimensions

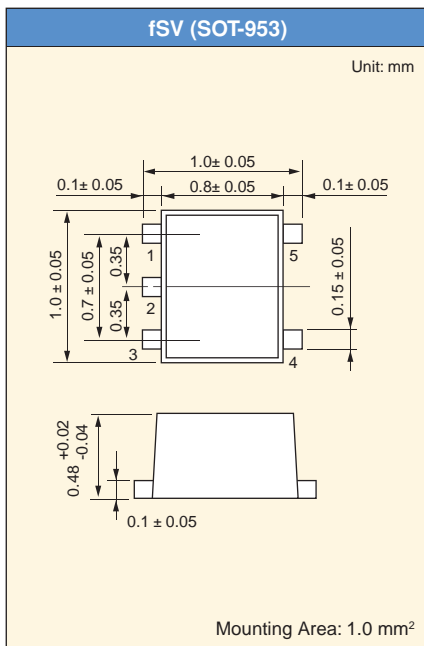

■ Land Pattern Example

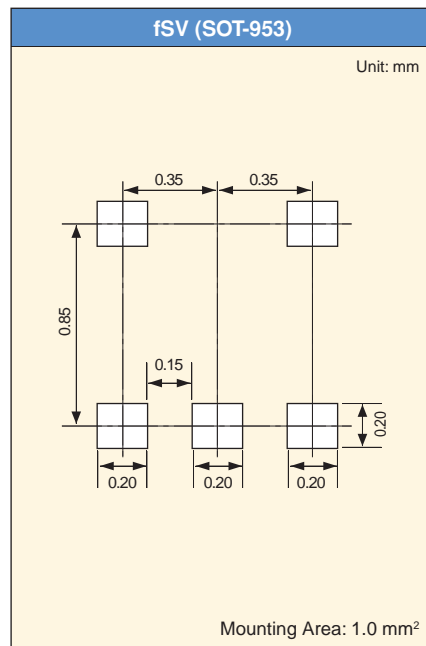

■ MP8 (SOT-902) Package

The LVP (TC7WGxxL8X) and SHS (TC7WZxxL8X) Series are available in MP8 (SOT-902) package.

■ Package Dimensions

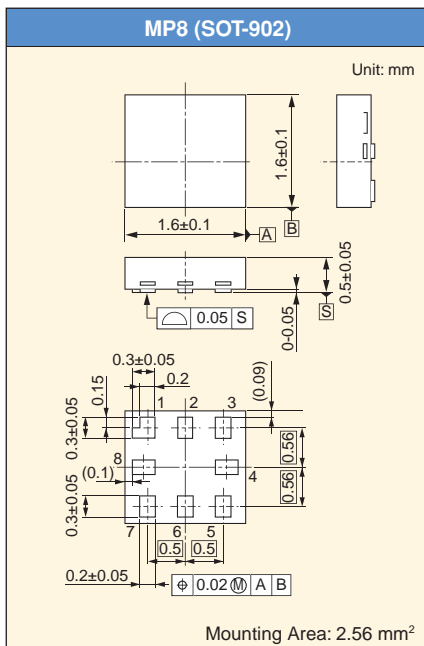

■ Land Pattern Example

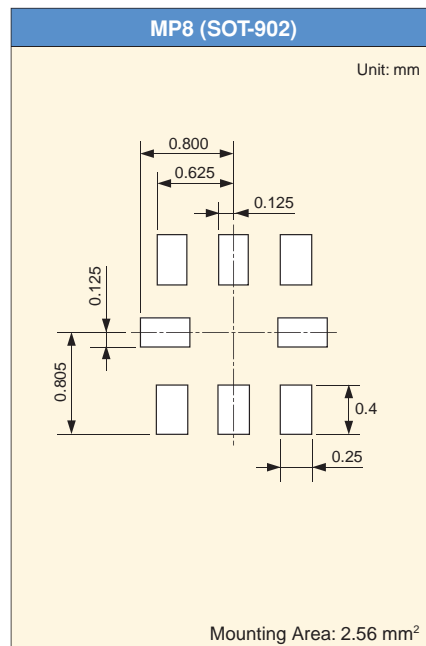

For reference only.
Be sure to verify device mountability.

Key Electrical Characteristics of the Low-Voltage, Low-Power LVP Series (Typ.)

High-level output current

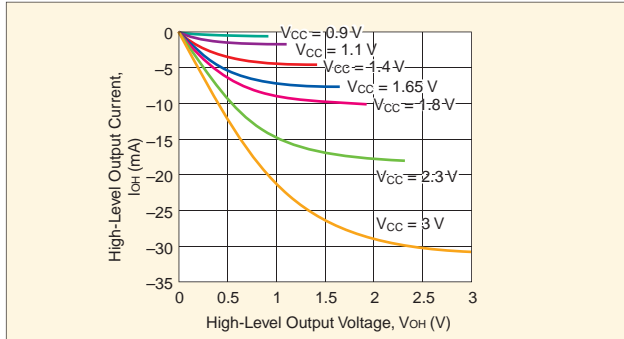

Low-level output current

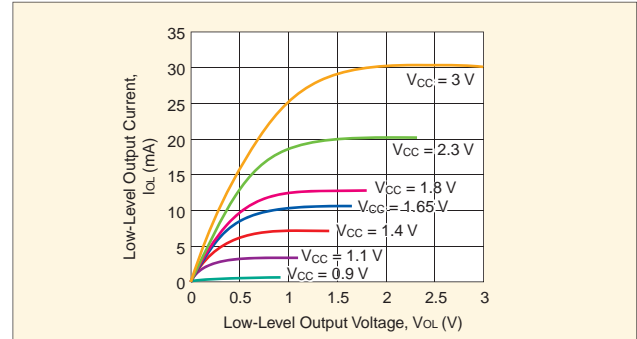

Maximum clock frequency (f_{MAX})

at $C_L = 15, 30$ pF ($f_{MAX} = 1/(t_{pd} \times 2)$)

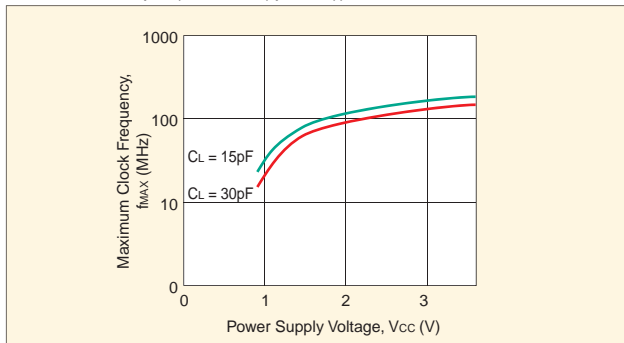

Propagation delay time as a function of load capacitance $t_{pd} - C_L$

at $V_{CC} = 1.8$ V

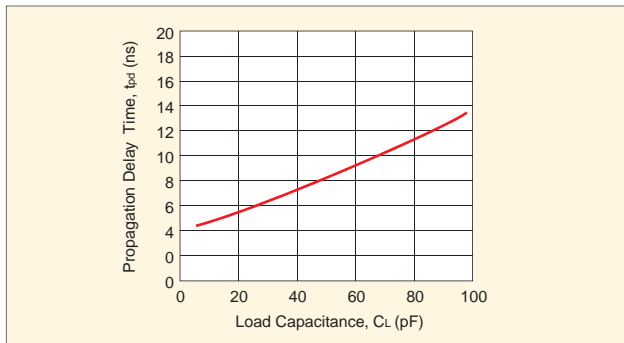

at $V_{CC} = 2.5$ V

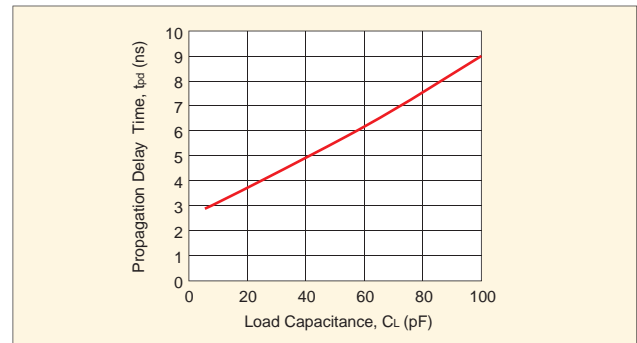

at $V_{CC} = 3.3$ V

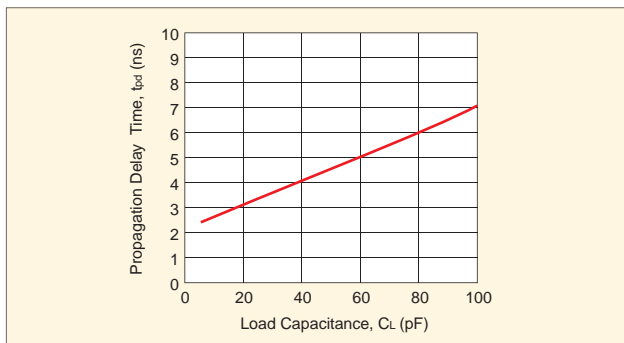

*These waveforms only represent typical device characteristics and are not necessarily guaranteed.

3

L-MOS (1- to 3-Gate Logic ICs)

Key Electrical Characteristics of the Low-Voltage, Low-Power LVP Series (Examples of NAND Function Switching Waveforms)

■ $V_{CC} = 1.5\text{ V}$, $C_L = 15\text{ pF}$, $R_L = 1\text{ M}\Omega$

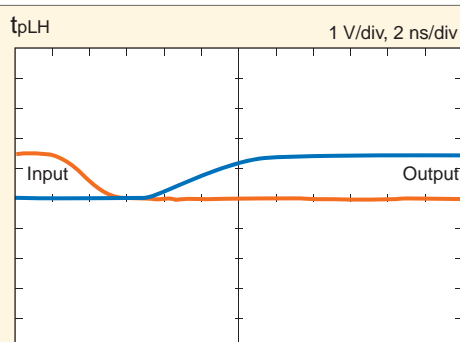
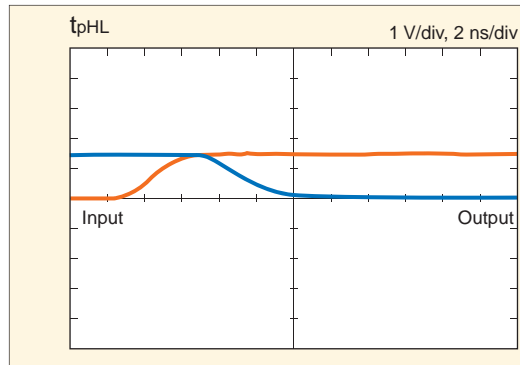

■ $V_{CC} = 1.8\text{ V}$, $C_L = 15\text{ pF}$, $R_L = 1\text{ M}\Omega$

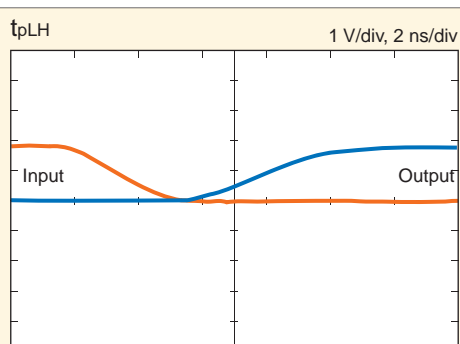
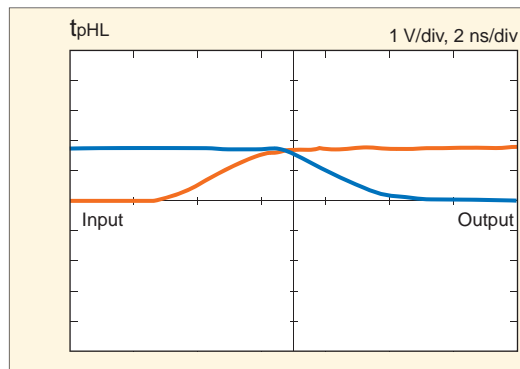

■ $V_{CC} = 2.5\text{ V}$, $C_L = 15\text{ pF}$, $R_L = 1\text{ M}\Omega$

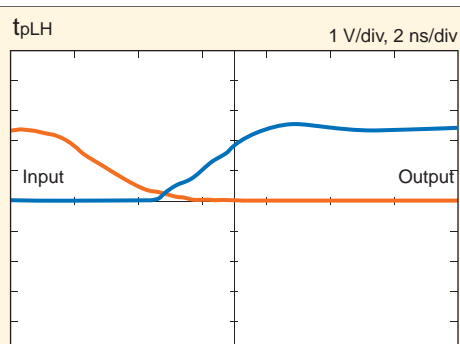
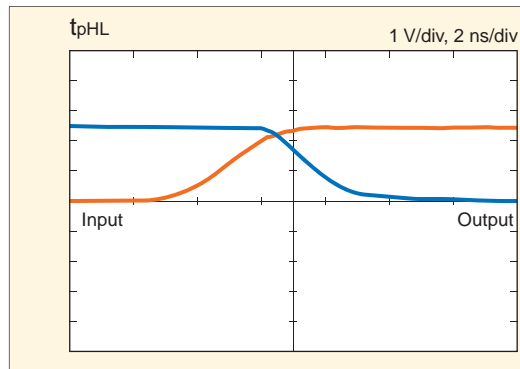

■ $V_{CC} = 3.3\text{ V}$, $C_L = 15\text{ pF}$, $R_L = 1\text{ M}\Omega$

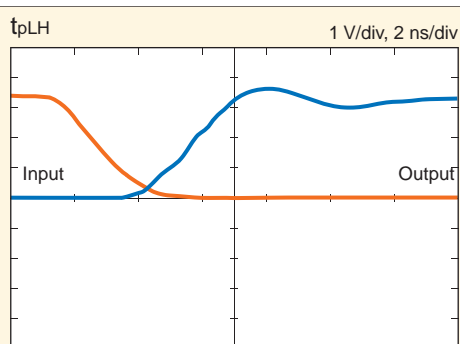
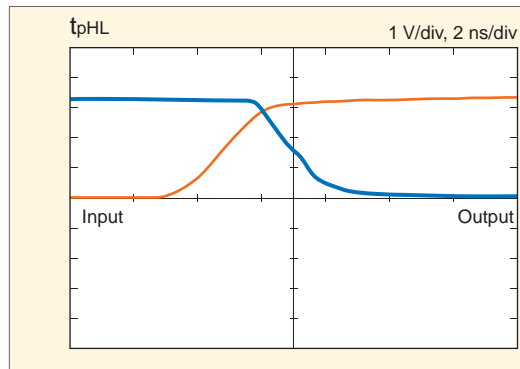

*These waveforms only represent typical device characteristics and are not necessarily guaranteed.

Key Electrical Characteristics of the Low-Voltage, Low-Power LVP Series (Examples of NAND Function Switching Waveforms)

■ $V_{CC} = 1.8\text{ V}$, $C_L = 30\text{ pF}$, $R_L = 1\text{ M}\Omega$

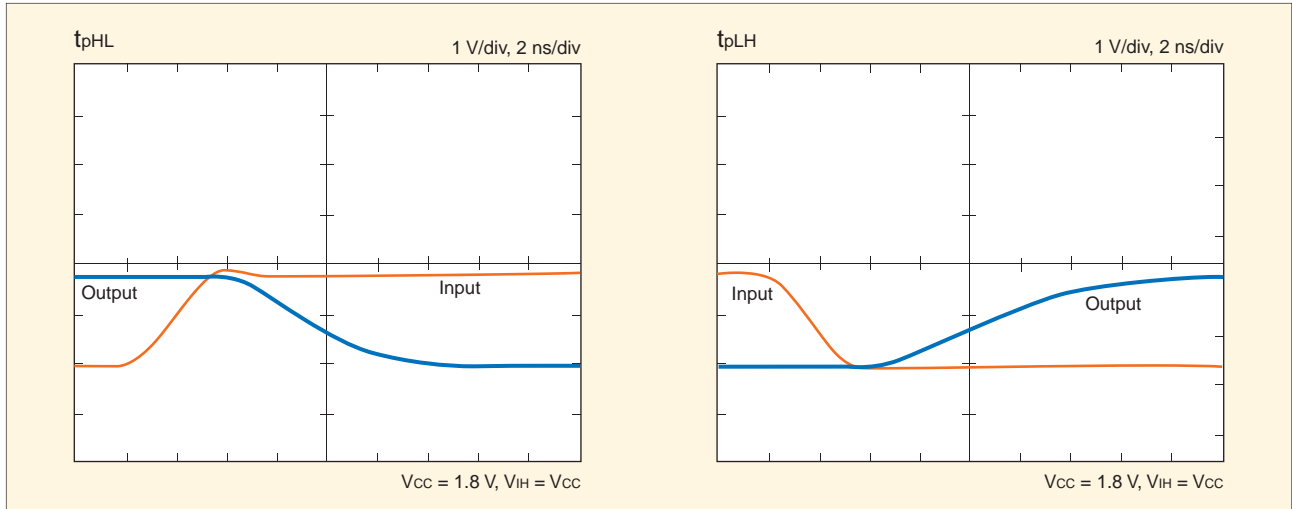

■ $V_{CC} = 2.5\text{ V}$, $C_L = 30\text{ pF}$, $R_L = 1\text{ M}\Omega$

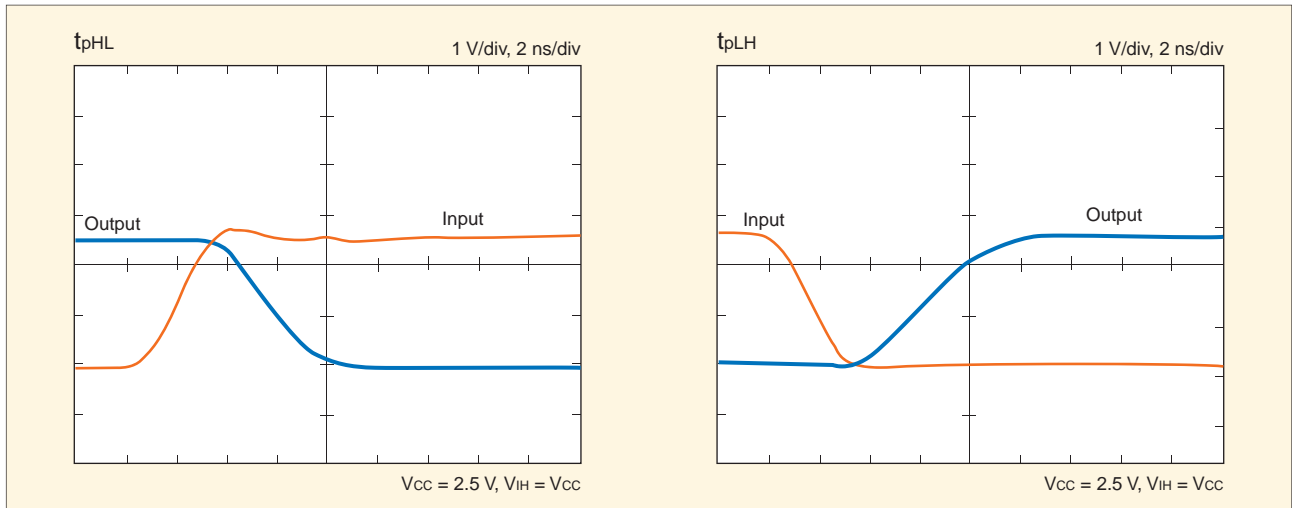

■ $V_{CC} = 3.3\text{ V}$, $C_L = 30\text{ pF}$, $R_L = 1\text{ M}\Omega$

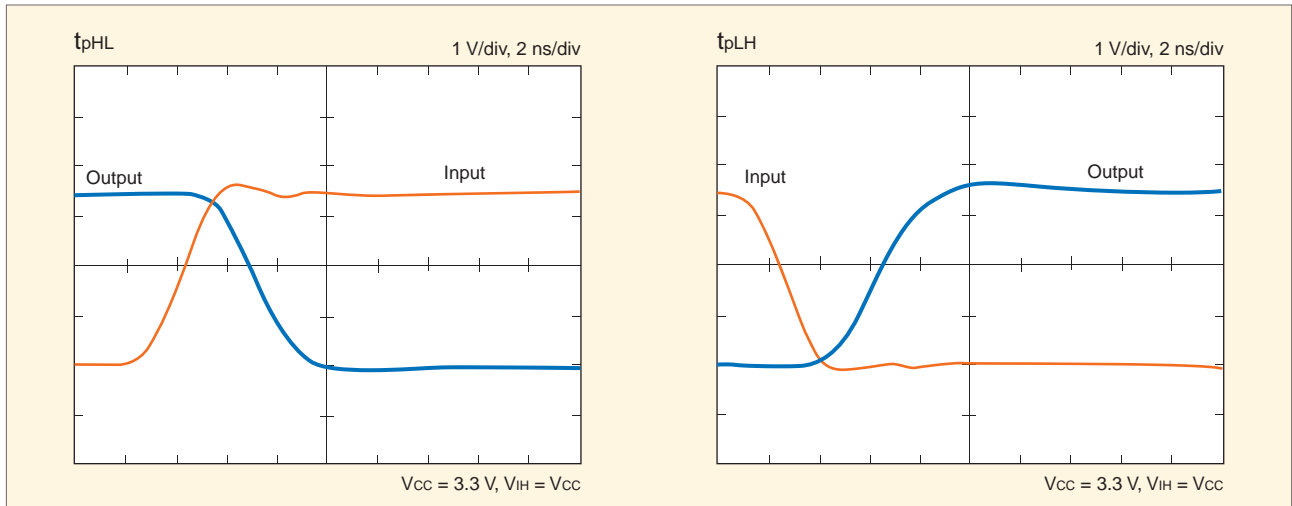

*These waveforms only represent typical device characteristics and are not necessarily guaranteed.

3

L-MOS (1- to 3-Gate Logic ICs)

3.3 L-MOS Performance Comparisons

The SHS Series is now available in the fSV package.

Parameter	LVP Series*2	AHS Series	SHS Series*1	VHS Series	High-Speed Series		TTL-Level Input Series	
	TC7SGxxFU/FE TC7SGxxAFS TC7PGxxAFE TC7WGxxFU/ FK/FC TC7WGxxL8X	TC7SAxxF/FU TC7PAxxFU/FE	TC7SZxxF/FU/FE TC7SZxxAFS TC7PZxxFU TC7WZxxFU/FK TC7WZxxL8X	TC7SHxxF/ FU/FE/FS TC7PHxxFE TC7WHxxFU/ FK/FC	TC7SxxF/FU	TC7WxxF/FU/FK	TC7SETxxF/FU	TC7WTxxFU
Propagation delay time (NAND GATE)	2.5 ns (typ.) at $V_{CC} = 3.3$ V $C_L = 15$ pF $T_a = 25^\circ\text{C}$	2.8 ns (max) at $V_{CC} = 3.3$ V $C_L = 30$ pF $R_L = 500 \Omega$ $T_a = -40$ to 85°C	2.4 ns (typ.) at $V_{CC} = 3.3$ V $C_L = 15$ pF $R_L = 1$ M Ω $T_a = 25^\circ\text{C}$	3.7 ns (typ.) at $V_{CC} = 5$ V $C_L = 15$ pF $T_a = 25^\circ\text{C}$	7 ns (typ.) at $V_{CC} = 5$ V $C_L = 15$ pF $T_a = 25^\circ\text{C}$	6 ns (typ.) at $V_{CC} = 5$ V $C_L = 15$ pF $T_a = 25^\circ\text{C}$	4.2 ns (typ.) at $V_{CC} = 5$ V $C_L = 15$ pF $T_a = 25^\circ\text{C}$	10 ns (typ.) (3-State Buffer) at $V_{CC} = 5.5$ V $C_L = 15$ pF $T_a = 25^\circ\text{C}$
Operating voltage	0.9 to 3.6 V	1.8 to 3.6 V	1.8 to 5.5 V 1.65 to 5.5 V*3	2 to 5.5 V	2 to 6 V	2 to 6 V	4.5 to 5.5 V	4.5 to 5.5 V
Input voltage tolerance	5.5 V	3.6 V	5.5 V	5.5 V	–	–	–	–
Output power-down protection	3.6 V*2 –*2	3.6 V	5.5 V*1 –*1	–	–	–	–	–
Output current	I_{OH} , I_{OL} 8 mA (min) at $V_{CC} = 3$ V	24 mA (min) at $V_{CC} = 3$ V	24 mA (min) at $V_{CC} = 3$ V	8 mA (min) at $V_{CC} = 4.5$ V	2 mA (min) at $V_{CC} = 4.5$ V	4 mA (min) at $V_{CC} = 4.5$ V	8 mA (min) at $V_{CC} = 4.5$ V	4 mA (min) at $V_{CC} = 4.5$ V
Electrical characteristics (except for permissible power dissipation rating)	–	Same as TC74VCxx series	Same as TC74LCxx series when $V_{CC} = 3.3$ V	Same as TC74VHCxxx series	Output current is 1/2 that of the TC74HCxxA series	Same as TC74HCxxA series	Accepts TTL-level inputs: $V_{IL} = 0.8$ V (max) $V_{IH} = 2.0$ V (min) Delivers full-swing outputs.	

*1: The TC7SZxxF/FU/FE, TC7PZxxFU and TC7WZxxFU/FK/L8X Series have input voltage tolerance and output power-down protection features. The TC7SZxxAFS Series has only input voltage tolerance feature.

*2: The TC7SGxxFU/FE, TC7PGxxFU and TC7WGxxFU/FK/FC/L8X Series have input voltage tolerance and output power-down protection features. TC7SGxxAFS and TC7PGxxAFE have only the input voltage tolerance feature.

*3: TC7WZxxFU/FK/L8X Series and TC7SZxxAFS/FE Series

■ Comparisons of Propagation Delay Times Among L-MOS Series

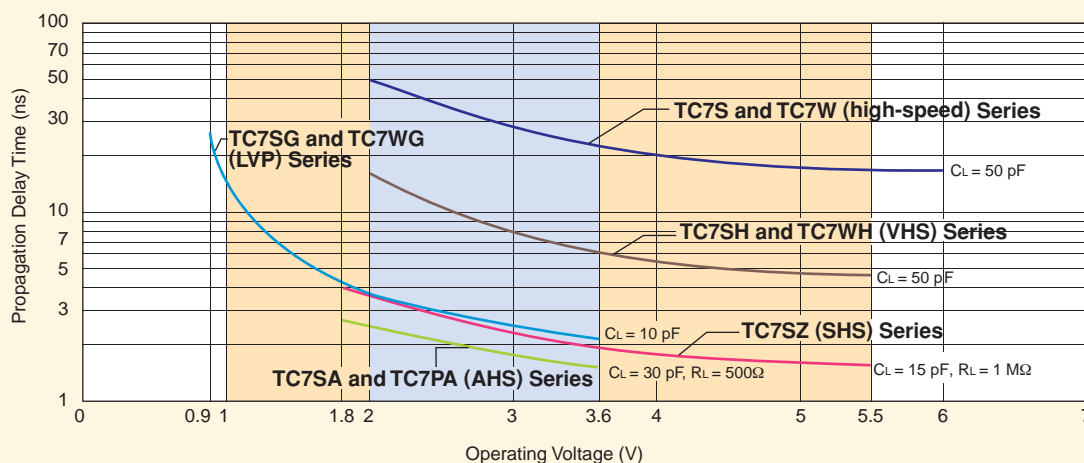

*These waveforms only represent typical device characteristics and are not necessarily guaranteed.

Low-Power-Consumption

The lowered power consumption helps to extend battery life for portable electronic devices.

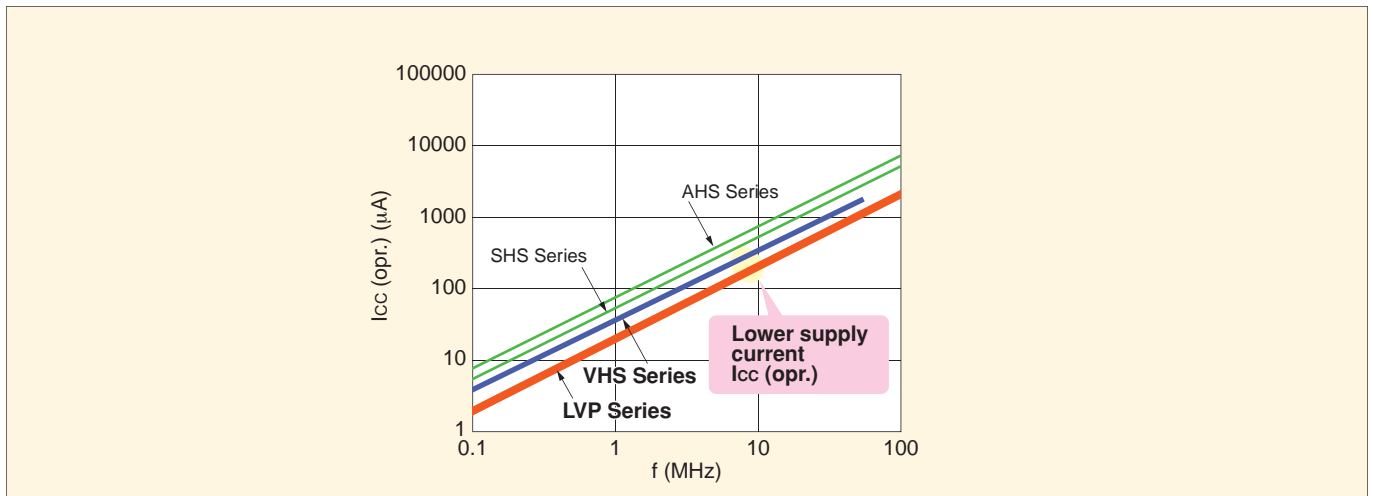

*These waveforms only represent typical device characteristics and are not necessarily guaranteed.

Optimal Switching Characteristics

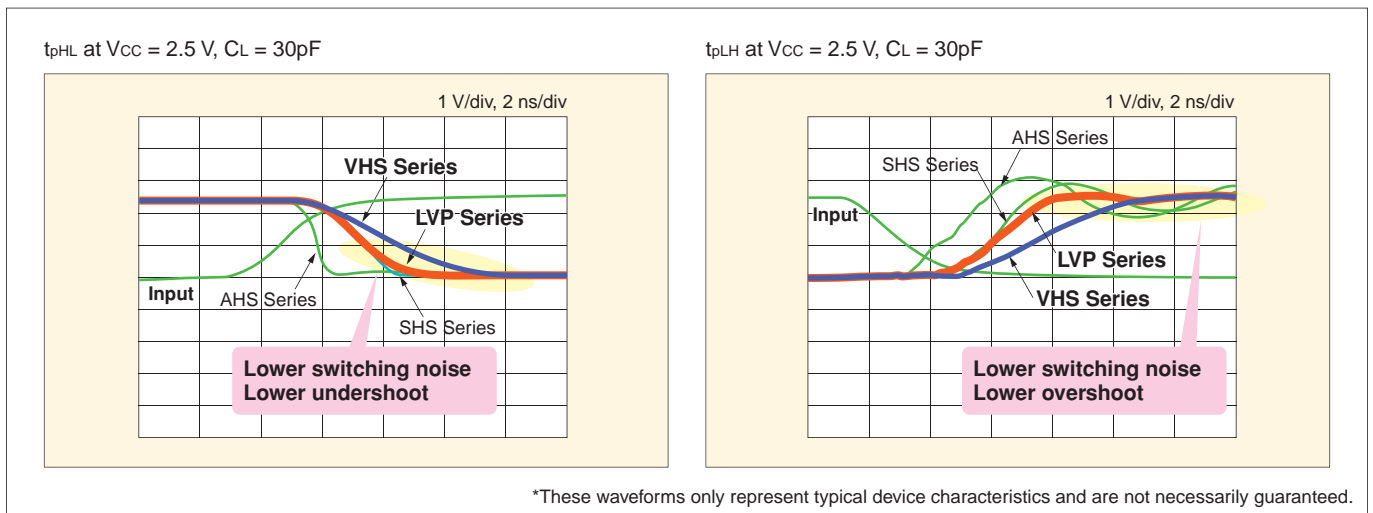

*These waveforms only represent typical device characteristics and are not necessarily guaranteed.

The optimized output circuits help to reduce switching noise.

Interface Characteristics

Interface Performance

The AHS, SHS, VHS and LVP Series incorporate tolerant input and power down protection output features.

- Tolerant inputs: Allows interfacing between components using different supply voltages (e.g., backup circuit)
- Power down protection outputs: Allows a voltage to be applied to an output when power is removed (for IC protection)

Input and Output Voltage Ranges

Series		LVP	SHS	AHS	VHS
Input voltage range	Active	0 to 5.5 V	0 to 5.5 V	0 to 3.6 V	0 to 5.5 V
	Power-down	0 to 5.5 V	0 to 5.5 V	0 to 3.6 V	0 to 5.5 V
Output voltage range	Output enabled	0 to Vcc	0 to Vcc	0 to Vcc	0 to Vcc
	Output disabled	0 to 3.6 V☆	0 to 5.5 V☆	0 to 3.6 V	0 to Vcc
	Power-down	0 to 3.6 V☆	0 to 5.5 V☆	0 to 3.6 V	0 to Vcc

☆: The permissible output voltage range of the TC7SGxxAFS, TC7PGxxAFE and TC7SZxxAFS Series is 0 to Vcc when outputs are disabled.

I/O Equivalent Circuit Diagrams

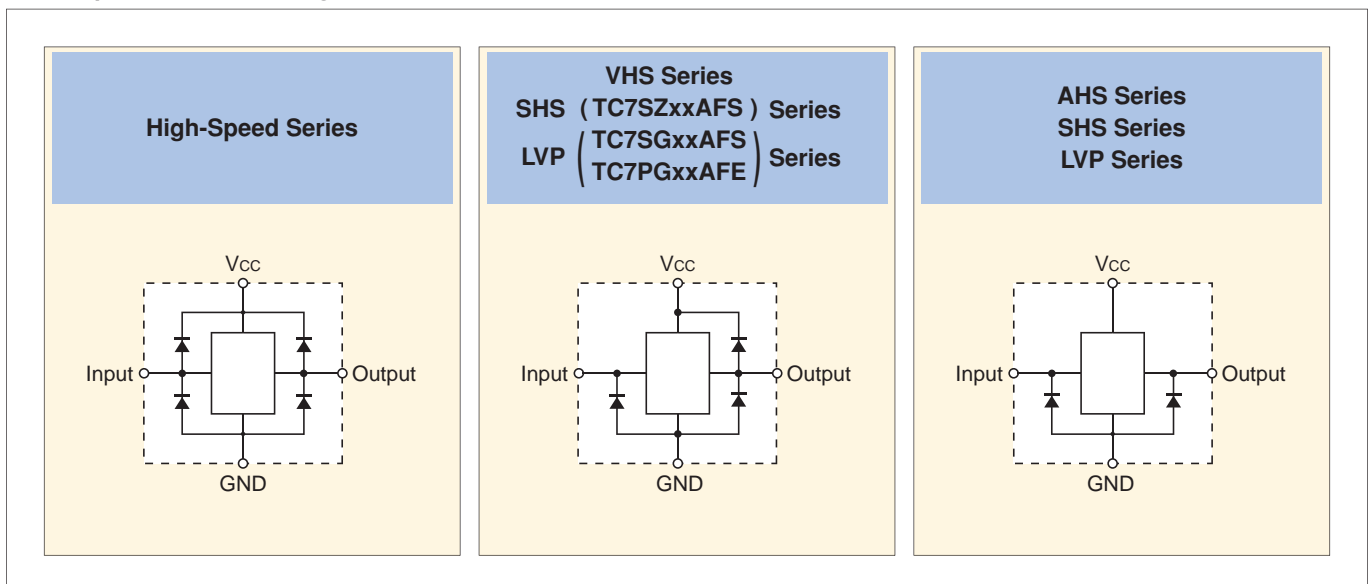

Direct Interfacing Between 3-V and 5-V Systems

As many CPUs and memories are now available in 3-V versions, many applications are being designed to operate in a mixed 3-V/5-V supply environment. Toshiba's L-MOS ICs act as an interface between 3-V and 5-V domains.

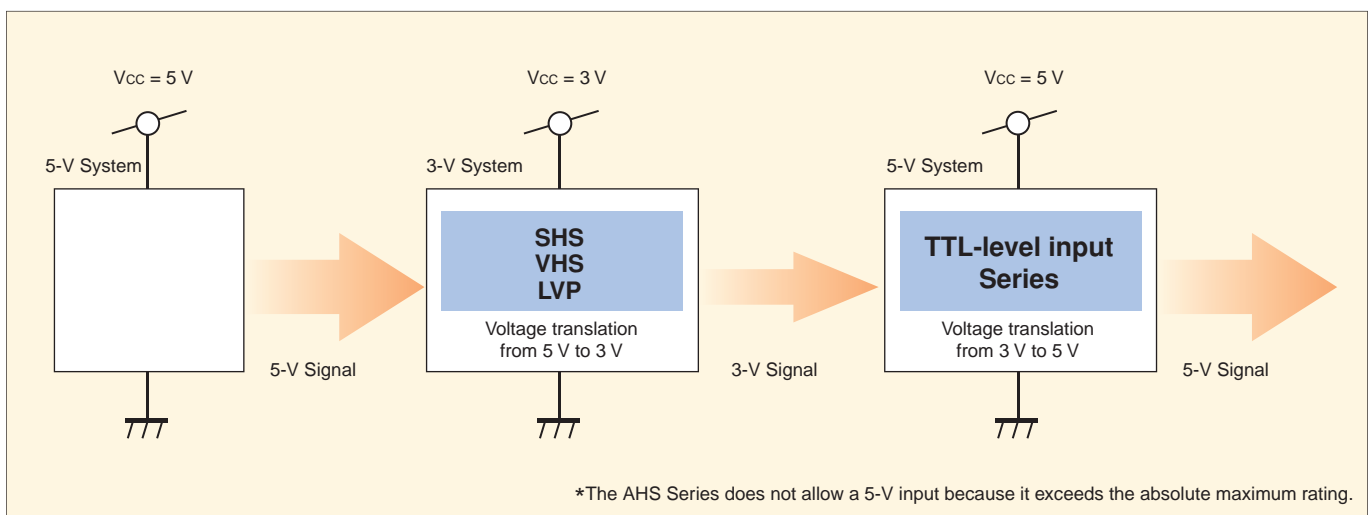

3.4 Typical Characteristics for Low-Voltage Logic Series

Drive Current (Typ.)

High-level output current

V_{CC} = 1.8 V, Ta = 25°C

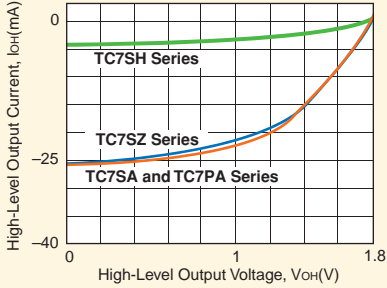

V_{CC} = 2.3 V, Ta = 25°C

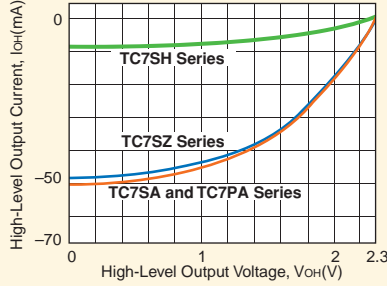

V_{CC} = 3.0 V, Ta = 25°C

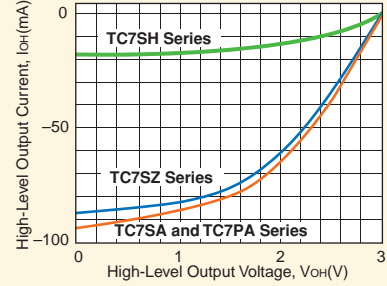

Low-level output current

V_{CC} = 1.8 V, Ta = 25°C

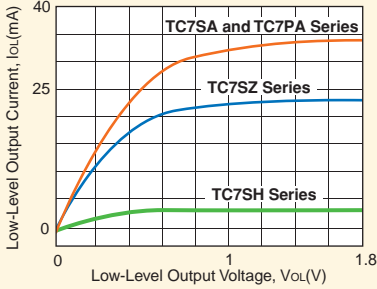

V_{CC} = 2.3 V, Ta = 25°C

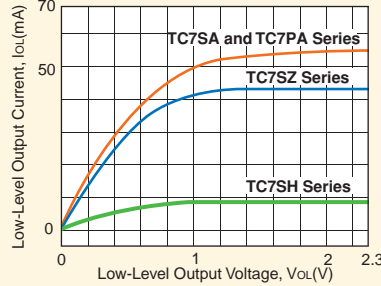

V_{CC} = 3.0 V, Ta = 25°C

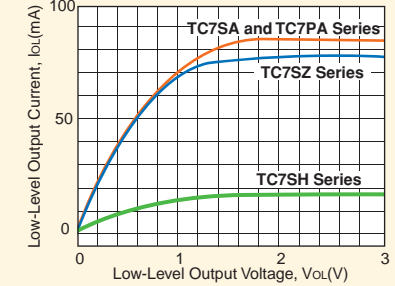

Typical Switching Waveforms of NAND Functions

t_{pHL}

V_{CC} = 1.8 V, C_L = 30 pF, R_L = 500 Ω, Ta = 25°C

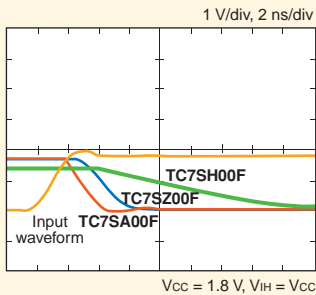

V_{CC} = 2.5 V, C_L = 30 pF, R_L = 500 Ω, Ta = 25°C

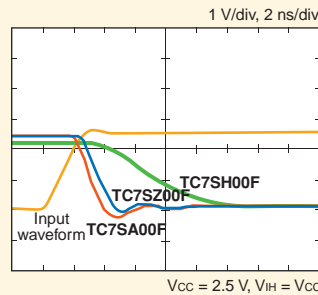

V_{CC} = 3.3 V, C_L = 30 pF, R_L = 500 Ω, Ta = 25°C

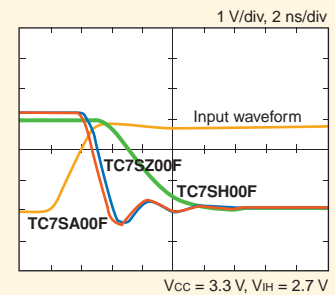

t_{pLH}

V_{CC} = 1.8 V, C_L = 30 pF, R_L = 500 Ω, Ta = 25°C

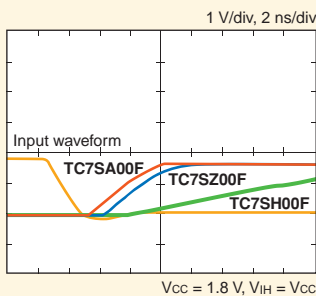

V_{CC} = 2.5 V, C_L = 30 pF, R_L = 500 Ω, Ta = 25°C

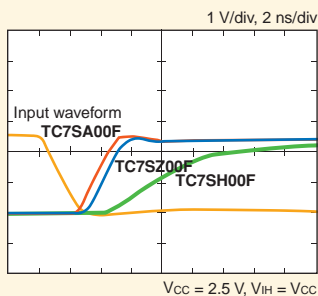

V_{CC} = 3.3 V, C_L = 30 pF, R_L = 500 Ω, Ta = 25°C

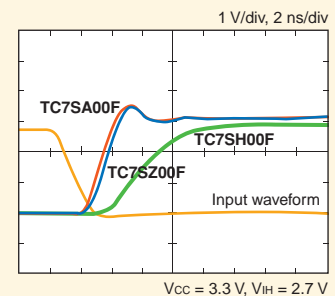

*These waveforms only represent typical device characteristics and are not necessarily guaranteed.

3 L-MOS (1- to 3-Gate Logic ICs)

3.5 Product Lineup by Series and Package

Function	LVP Series								AHS Series			SHS Series						VHS Series						VHS TTL-Level Input Series		High-Speed Series				TTL-Level Input Series		Standard Series									
	fSV (SOT-953)	ESV (SOT-553)	USV (SOT-353) (SC-88A)	ES6 (SOT-563)	US6 (SOT-363) (SC-88)	CST8	MP8 (SOT-902)	US8 (SOT-765)	SM8 (SOT-505)	USV (SOT-353) (SC-88A)	SMV (SOT-25) (SC-74A)	ES6 (SOT-563)	US6 (SOT-363) (SC-88)	fSV (SOT-953)	ESV (SOT-553)	USV (SOT-353) (SC-88A)	SMV (SOT-25) (SC-74A)	US6 (SOT-363) (SC-88)	MP8 (SOT-902)	US8 (SOT-765)	SM8 (SOT-505)	fSV (SOT-953)	ESV (SOT-553)	USV (SOT-353) (SC-88A)	SMV (SOT-25) (SC-74A)	ES6 (SOT-563)	CST8	US8 (SOT-765)	SM8 (SOT-505)	USV (SOT-353) (SC-88A)	SMV (SOT-25) (SC-74A)	USV (SOT-353) (SC-88A)	SMV (SOT-25) (SC-74A)	US8 (SOT-765)	SM8 (SOT-505)	SM8 (SOT-505)	SMV (SOT-25) (SC-74A)	SM8 (SOT-505)			
Operating Supply Voltage	0.9 to 3.6 V								1.8 to 3.6 V			1.65 to 5.5 V		1.8 to 5.5 V		1.65 to 5.5 V		2 to 5.5 V						4.5 to 5.5 V		2 to 6 V				4.5 to 5.5 V		3 to 18 V									
I _{OH} /I _{OL}	8 mA min at V _{CC} = 3 V								24 mA min at V _{CC} = 3 V			24 mA min at V _{CC} = 3 V						8 mA min at V _{CC} = 4.5 V						2 mA min (TC7S series), 4 mA min (TC7W series), 4 mA min (TTL-level input series) at V _{CC} = 4.5 V				0.42 mA min at V _{CC} = 5 V													
t _{PLH} /t _{PHL} (NAND gate)	2.5 ns typ. at V _{CC} = 3.3 V C _L = 15 pF, T _a = 25°C								2.8 ns max at V _{CC} = 3.3 V C _L = 15 pF, T _a = 25°C			2.4 ns typ. at V _{CC} = 3.3 V C _L = 15 pF, T _a = 25°C						3.7 ns typ. at V _{CC} = 5 V, C _L = 15 pF, T _a = 25°C						4.2 ns typ. at V _{CC} = 5 V, C _L = 15 pF, T _a = 25°C		7 ns typ. (TC7S series), 6 ns typ. (TC7W series), 10 ns typ. (TTL-level input series) at V _{CC} = 5 V, C _L = 15 pF, T _a = 25°C				65 ns typ. at V _{CC} = 5 V, C _L = 15 pF, T _a = 25°C											
Tolerant input	Yes								Yes			Yes						Yes						No		No				No											
Power down protection output	No	Yes			No	Yes			Yes	No	Yes	No	Yes						No						No				No												
NAND	TC7SG00AFS	TC7SG00FE	TC7SG00FU			TC7WG00FC	TC7WG00L8X	TC7WG00FK	TC7WG00FU	TC7SA00FU	TC7SA00F		TC7SZ00AFS	TC7SZ00FE	TC7SZ00FU	TC7SZ00F		TC7WZ00L8X	TC7WZ00FK	TC7WZ00FU	TC7SH00FS	TC7SH00FE	TC7SH00FU	TC7SH00F		TC7WH00FC	TC7WH00FK	TC7WH00FU	TC7SET00FU	TC7SET00F	TC7S00FU	TC7S00F	TC7W00FK	TC7W00FU				TC4S11F			
NAND (Unbuffered)																																						TC4SU11F			
NAND (Open-Drain)																																									
AND	TC7SG08AFS	TC7SG08FE	TC7SG08FU			TC7WG08FC	TC7WG08L8X	TC7WG08FK	TC7WG08FU	TC7SA08FU	TC7SA08F		TC7SZ08AFS	TC7SZ08FE	TC7SZ08FU	TC7SZ08F		TC7WZ08L8X	TC7WZ08FK	TC7WZ08FU	TC7SH08FS	TC7SH08FE	TC7SH08FU	TC7SH08F		TC7WH08FC	TC7WH08FK	TC7WH08FU	TC7SET08FU	TC7SET08F	TC7S08FU	TC7S08F	TC7W08FK	TC7W08FU						TC4S81F	
NOR	TC7SG02AFS	TC7SG02FE	TC7SG02FU			TC7WG02FC	TC7WG02L8X	TC7WG02FK	TC7WG02FU				TC7SZ02AFS	TC7SZ02FE	TC7SZ02FU	TC7SZ02F		TC7WZ02L8X	TC7WZ02FK	TC7WZ02FU	TC7SH02FS	TC7SH02FE	TC7SH02FU	TC7SH02F		TC7WH02FC	TC7WH02FK	TC7WH02FU	TC7SET02FU	TC7SET02F	TC7S02FU	TC7S02F	TC7W02FK	TC7W02FU						TC4S01F	
OR	TC7SG32AFS	TC7SG32FE	TC7SG32FU			TC7WG32FC	TC7WG32L8X	TC7WG32FK	TC7WG32FU	TC7SA32FU	TC7SA32F		TC7SZ32AFS	TC7SZ32FE	TC7SZ32FU	TC7SZ32F		TC7WZ32L8X	TC7WZ32FK	TC7WZ32FU	TC7SH32FS	TC7SH32FE	TC7SH32FU	TC7SH32F		TC7WH32FC	TC7WH32FK	TC7WH32FU	TC7SET32FU	TC7SET32F	TC7S32FU	TC7S32F	TC7W32FK	TC7W32FU						TC4S71F	
Exclusive-OR	TC7SG86AFS	TC7SG86FE	TC7SG86FU			TC7WG86FC	TC7WG86L8X						TC7SZ86AFS	TC7SZ86FE	TC7SZ86FU	TC7SZ86F		TC7WZ86L8X			TC7SH86FS	TC7SH86FE	TC7SH86FU	TC7SH86F		TC7WH86FC	TC7WH86FK	TC7WH86FU	TC7SET86FU	TC7SET86F	TC7S86FU	TC7S86F						TC4S30F			
Inverter	TC7SG04AFS	TC7SG04FE	TC7SG04FU	TC7PG04AFE	TC7PG04FU	TC7WG04FC	TC7WG04L8X	TC7WG04FK	TC7WG04FU	TC7SA04FU	TC7SA04F		TC7PA04FU	TC7S204AFS	TC7S204FE	TC7S204FU	TC7S204F		TC7WZ04L8X	TC7WZ04FK	TC7WZ04FU	TC7SH04FS	TC7SH04FE	TC7SH04FU	TC7SH04F	TC7PH04FE	TC7WH04FC	TC7WH04FK	TC7WH04FU	TC7SET04FU	TC7SET04F	TC7S04FU	TC7S04F	TC7W04FK	TC7W04FU				TC4S69F		
Inverter ¹ (Unbuffered)	TC7SGU04AFS	TC7SGU04FE	TC7SGU04FU	TC7PGU04AFE	TC7PGU04FU	TC7WGU04FC	TC7WGU04L8X	TC7WGU04FK	TC7WGU04FU	TC7SAU04FU	TC7SAU04F		TC7PAU04FU	TC7S204AFS	TC7S204FE	TC7S204FU	TC7S204F		TC7WZU04L8X	TC7WZU04FK	TC7WZU04FU	TC7SHU04FS	TC7SHU04FE	TC7SHU04FU	TC7SHU04F		TC7WHU04FC	TC7WHU04FK	TC7WHU04FU			TC7SU04FU	TC7SU04F	TC7WU04FK	TC7WU04FU				TC4S69F		
Inverter ² (Open-Drain)	TC7SG05AFS	TC7SG05FE					TC7WG05L8X			TC7SA05FU	TC7SA05F		TC7PA05FU	TC7S205AFS	TC7S205FE	TC7S205FU	TC7S205F		TC7WZ05L8X	TC7WZ05FK	TC7WZ05FU	TC7SH05FS	TC7SH05FE																		
Non-Inverter ² (Open-Drain)	TC7SG07AFS	TC7SG07FE					TC7WG07L8X						TC7PA07FU	TC7S207AFS	TC7S207FE	TC7S207FU	TC7S207F		TC7WZ07L8X	TC7WZ07FK	TC7WZ07FU	TC7SH07FS	TC7SH07FE																		
Schmitt Inverter	TC7SG14AFS	TC7SG14FE	TC7SG14FU	TC7PG14AFE	TC7PG14FU	TC7WG14FC	TC7WG14L8X	TC7WG14FK	TC7WG14FU			TC7PA14FU	TC7S214AFS	TC7S214FE	TC7S214FU	TC7S214F	TC7PZ14FU	TC7WZ14L8X	TC7WZ14FK	TC7WZ14FU	TC7SH14FS	TC7SH14FE	TC7SH14FU	TC7SH14F		TC7WH14FC	TC7WH14FK	TC7WH14FU	TC7SET14FU	TC7SET14F	TC7S14FU	TC7S14F	TC7W14FK	TC7W14FU					TC4S584F		
Schmitt Buffer	TC7SG17AFS	TC7SG17FE	TC7SG17FU	TC7PG17AFE	TC7PG17FU	TC7WG17FC	TC7WG17L8X	TC7WG17FK	TC7WG17FU			TC7PA17FU	TC7S217AFS	TC7S217FE	TC7S217FU	TC7S217F	TC7PZ17FU	TC7WZ17L8X									TC7WH17FC	TC7WH17FK	TC7WH17FU	TC7SET17FU	TC7SET17F										
Non-Inverter	TC7SG34AFS	TC7SG34FE	TC7SG34FU	TC7PG34AFE	TC7PG34FU	TC7WG34FC	TC7WG34L8X	TC7WG34FK	TC7WG34FU	TC7SA34FU	TC7SA34F		TC7PA34FU	TC7S234AFS	TC7S234FE	TC7S234FU	TC7S234F		TC7WZ34L8X	TC7WZ34FK	TC7WZ34FU	TC7SH34FS	TC7SH34FE	TC7SH34FU	TC7SH34F	TC7PH34FE	TC7WH34FC	TC7WH34FK	TC7WH34FU	TC7SET34FU	TC7SET34F										
Analog Switch																																						TC4S66F	TC4S66FU (USV)	TC4W66FU	
Analog Multiplexer													TC7PA53FU																										TC4W53FU		
D-Type Flip-Flop with Preset and Clear						TC7WG74FC	TC7WG74L8X	TC7WG74FK	TC7WG74FU										TC7WZ74L8X	TC7WZ74FK	TC7WZ74FU						TC7WH74FC	TC7WH74FK	TC7WH74FU												
D-Type Flip-Flop	TC7SG79AFS		TC7SG79FU																																						
D-Type Flip-Flop with Clear	TC7SG80AFS		TC7SG80FU																																						
3-State Buffer	TC7SG125AFS	TC7SG125FE	TC7SG125FU			TC7WG125FC	TC7WG125L8X	TC7WG125FK	TC7WG125FU				TC7SZ125AFS	TC7SZ125FE	TC7SZ125FU	TC7SZ125F		TC7WZ125L8X	TC7WZ125FK	TC7WZ125FU	TC7SH125FS	TC7SH125FE	TC7SH125FU	TC7SH125F		TC7WH125FC	TC7WH125FK	TC7WH125FU	TC7SET125FU	TC7SET125F										TC7W125FU	TC7W125FU
3-State Buffer	TC7SG126AFS	TC7SG126FE	TC7SG126FU			TC7WG126FC	TC7WG126L8X	TC7WG126FK	TC7WG126FU				TC7SZ126AFS	TC7SZ126FE	TC7SZ126FU	TC7SZ126F		TC7WZ126L8X	TC7WZ126FK	TC7WZ126FU	TC7SH126FS	TC7SH126FE	TC7SH126FU	TC7SH126F		TC7WH126FC	TC7WH126FK	TC7WH126FU	TC7SET126FU	TC7SET126F										TC7W126FU	TC7W126FU
3-State Inverting Buffer																											TC7WH240FK	TC7WH240FU											TC7W240FU	TC7W240FU	
3-State Buffer																											TC7WH241FK	TC7WH241FU											TC7W241FU	TC7W241FU	
Bus Transceiver																											TC7WZ245FK	TC7WZ245FU													
Bus Transceiver (Open-Drain)																											TC7WZ246FK	TC7WZ246FU													
Monostable Multivibrator																											TC7WH123FK	TC7WH123FU													
Digital Multiplexer																											TC7WH157FC	TC7WH157FK	TC7WH157FU												
1-to-2 Decoder													TC7PA19AFE	TC7PA19FU																											
2-to-4 Decoder																																								TC7W138FU	

*1: The U04 function in all product series has no power down protection output feature.
 *2: The 05 and 07 functions in all product series has power down protection output feature.

■ New product ■ Under development

Part Naming Conventions TC 7 S H U 04 FU

- ①..... Toshiba CMOS device
- ②-④..... Product series
 - 4..... Standard Series
 - 7..... High-Speed Series
 - 7_H..... VHS Series
 - 7_E..... VHS TTL-Level Input Series
 - 7_Z..... SHS Series
 - 7_A..... AHS Series
 - 7_G..... LVP Series
- ⑤..... Number of Pins
 - S : 5 pins
 - P : 6 pins
 - W : 8 pins
- ⑥..... U : Unbuffered
 - T : TTL-level inputs
 - Blank : Buffered
- ⑦..... Letter beginning with A for upgraded versions
- ⑧..... Package type
 - F : SMV
 - FU : SM8, USV or US6
 - FK : US8
 - FE : ESV or ES6
 - FC : CST8
 - FS : fSV
 - L8X : MP8

Package Lineup

Toshiba Package Name	fSV (SOT-953)	ESV (SOT-553)	USV (SOT-353, SC-88A)	SMV (SOT-25, SC-74A)	ES6 (SOT-563)	US6 (SOT-363, SC-88)	CST8	MP8 (SOT-902)	US8 (SOT-765)	SM8 (SOT-505)
Package Dimensions										

3

L-MOS (1- to 3-Gate Logic ICs)

3.6 Pin Assignments (Top View)

5-Pin Single-Gate Logic Packages: SMV (SOT-25)(SC-74A), USV (SOT-353)(SC-88A), ESV (SOT-553)

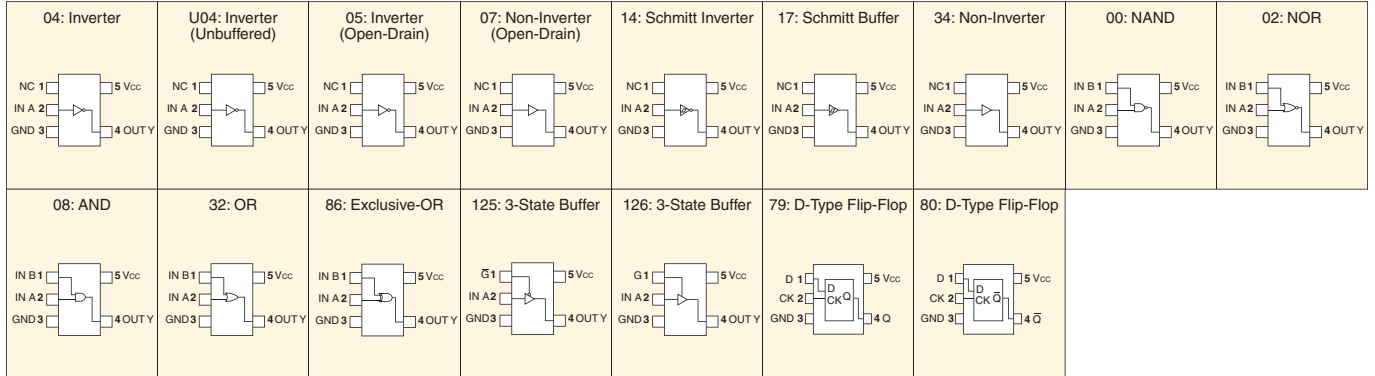

5-Pin Single-Gate Logic Package: fSV (SOT-953)

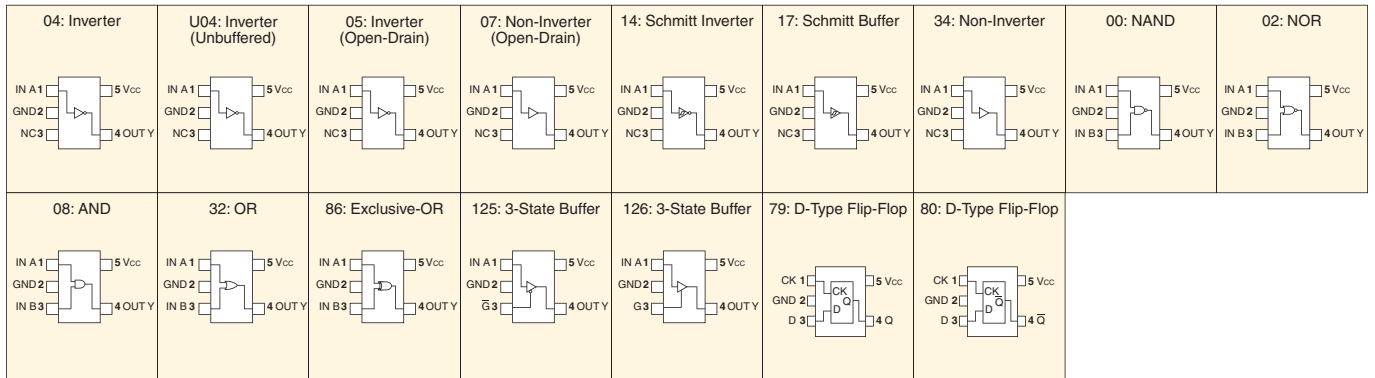

6-Pin Dual-Gate Logic Packages: US6 (SOT-363)(SC-88), ES6 (SOT-563)

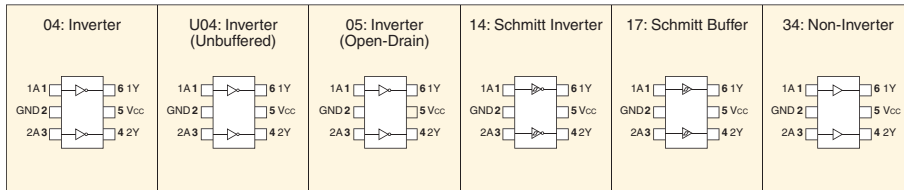

6-Pin Single-Gate Logic Packages: US6 (SOT-363)(SC-88), ES6 (SOT-563)

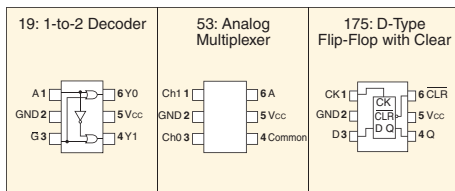

8-Pin Triple-Gate Logic Packages: SM8 (SOT-505), US8 (SOT-765)

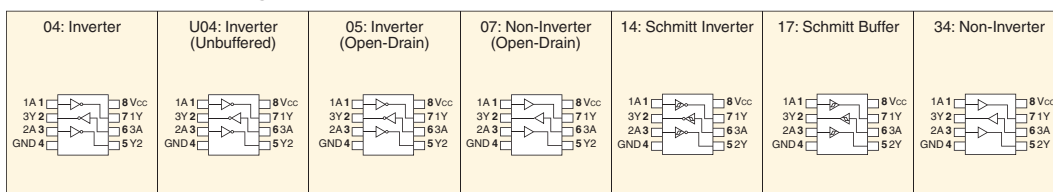

8-Pin Triple-Gate Logic Package: CST8

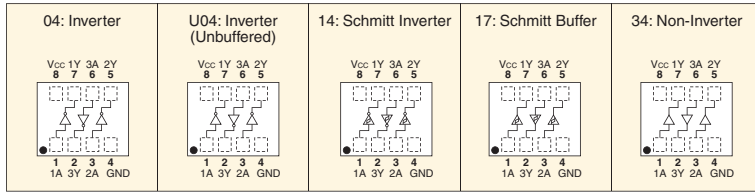

8-Pin Triple-Gate Logic Package: MP8 (SOT-902)

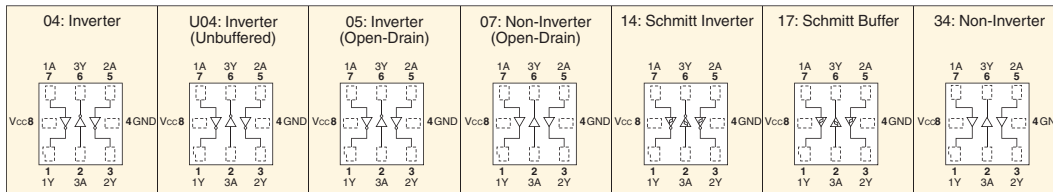

8-Pin Dual-Gate Logic Packages: SM8 (SOT-505), US8 (SOT-765)

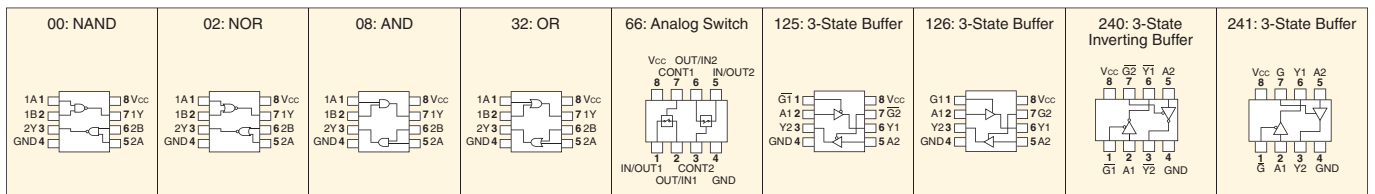

8-Pin Dual-Gate Logic Package: CST8

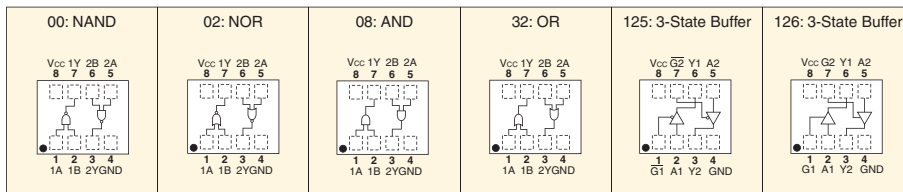

8-Pin Dual-Gate Logic Package: MP8 (SOT-902)

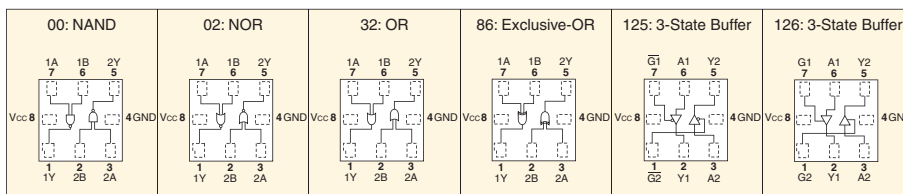

8-Pin Single-Gate Logic Packages: SM8 (SOT-505), US8 (SOT-765)

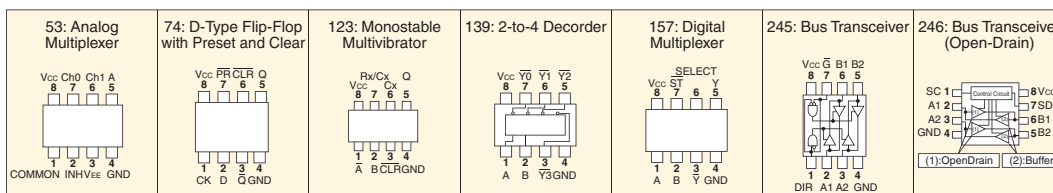

8-Pin Single-Gate Logic Package: CST8

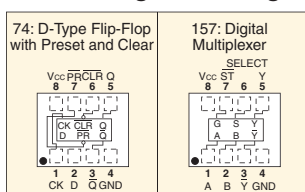

8-Pin Single-Gate Logic Package: MP8 (SOT-902)

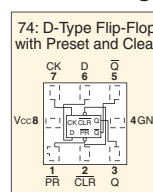

4

LDO (Low-Dropout Regulators)

4.1 CMOS LDO Regulators

200-mA CMOS LDO Regulators in a Ultra-Small Package (Single-Output) TCR4SxxWBG and TCR4SxxDWBG Series

CMOS LDO regulators are now available in the WCSP4 ultra-small package

New Product

The WCSP4 package occupies only 0.63 mm² of board area and is thus ideal for applications that require high-density board assembly. The CMOS LDO regulators in the WCSP4 package are available with a fixed output voltage between 1.2 V and 3.6 V. The output voltage is able to fix in steps of 50 mV.

The TCR4SxxDWBG Series provides an auto-discharge function, which makes it ideal for applications with complex timing control.

Applications

Cell phones, digital still cameras, portable audio players and other compact portable equipment

Features

- High ripple rejection: R.R = 80 dB (typ.) at $I_{OUT} = 10$ mA, $f = 1$ kHz
- Low noise voltage: $V_{NO} = 30$ μ Vrms (typ.) at 2.5-V output, $I_{OUT} = 10$ mA, 10 Hz $\leq f \leq 100$ kHz
- Over current protection
- Auto-Discharge Function (TCR4SxxDWBG)
- Pull-down connection internally at the CONTROL pin (TCR4SxxDWBG)
- Allows the use of ceramic capacitors ($C_{IN} = 0.1$ μ F, $C_{OUT} = 1.0$ μ F)
- Ultra-small package: WCSP4 (0.79 x 0.79 x 0.50 mm)

Package Dimensions

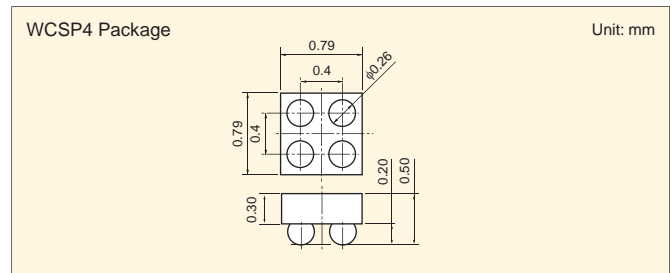

Auto-Discharge Function

(Example shown for a 1.5-V LDO regulator)

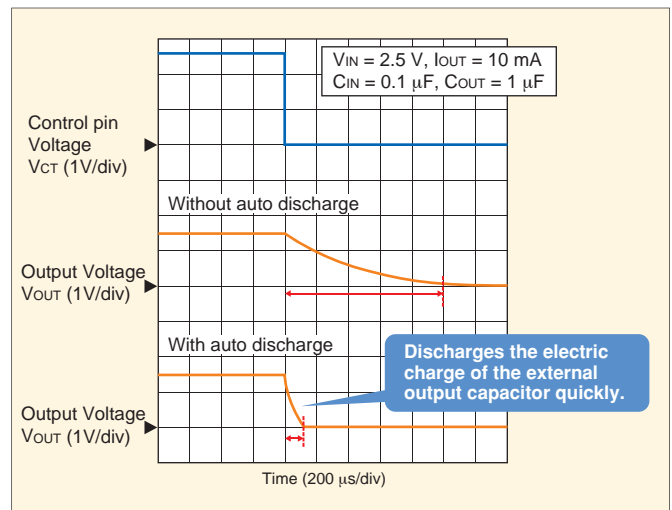

Part Number	V _{OUT} (V)	Control Pin Connection	Auto Discharge
TCR4S15WBG	1.5	Open	No
TCR4S18WBG	1.8		
TCR4S28WBG	2.8		
TCR4S30WBG	3.0		
TCR4S12DWBG	1.2	Pull-down	Yes
TCR4S15DWBG	1.5		
TCR4S18DWBG	1.8		
TCR4S20DWBG	2.0		
TCR4S21DWBG	2.1		
TCR4S25DWBG	2.5		
TCR4S26DWBG	2.6		
TCR4S27DWBG	2.7		
TCR4S28DWBG	2.8		
TCR4S285DWBG	2.85		
TCR4S29DWBG	2.9		
TCR4S295DWBG	2.95		
TCR4S30DWBG	3.0		
TCR4S33DWBG	3.3		

New product

Single-Output CMOS Low-Dropout Regulators

CMOS low-dropout (LDO) regulators are available in four package styles: ultra-small WCSP4 (0.79 x 0.79 x 0.5 mm), SMV (SOT-25, SC-74A), UFV and ESV (SOT-553). These LDO regulators allow the use of small ceramic capacitors as the input and output capacitors, making them ideal for applications that require high-density board assembly.

Application Examples Mobile handsets

Package Dimensions

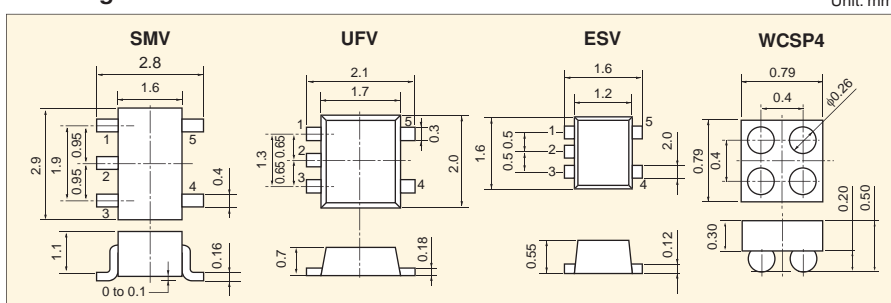

Application Circuit Example (SMV/UFV)

Ceramic capacitors can be used as input and output capacitors.

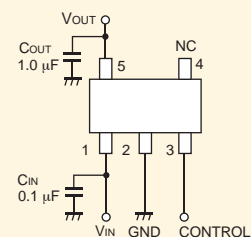

CONTROL	V _{OUT}
High	ON
Low	OFF

Standard Series

Features

- Low bias current
- Low-output voltage devices are available.
- Overcurrent protection
- Auto-Discharge Function (TCR4SxxDWBG)
- Internal pull-down resistor at the CONTROL pin (TCR4SxxDWBG)
- Allows use of ceramic capacitors on the input and output lines.
- Small packages: Available in SMV, ESV and WCSP4 packages.

Application Circuit Example (WCSP4)

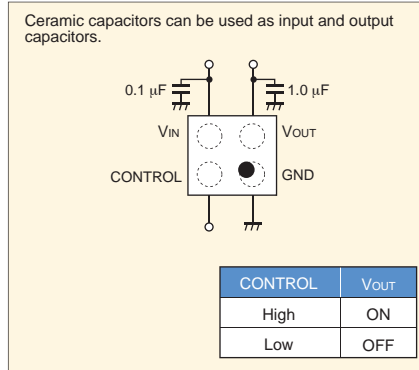

Application Circuit Example (ESV)

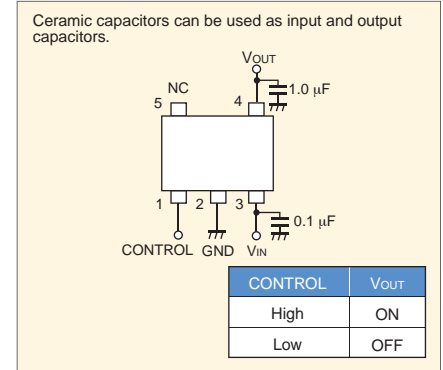

CMOS LDO Regulator Series in the WCSP4 Package

Part Number		Output Current (mA)	Output Voltage (V)	Maximum Input Voltage (V)	Dropout Voltage (mV)	Bias Current (μA)	Ripple Rejection Ratio (dB)	Output Noise Voltage (μVrms)	
Without Auto-Discharge	With Auto-Discharge								
TCR4S12WBG	TCR4S12DWBG	200	1.2	5.5	400 (Typ.)@I _{OUT} = 50 mA	75 (Max)	80 (Typ.) @1 kHz	25 (Typ.)	
	TCR4S13DWBG		1.3		350 (Typ.)@I _{OUT} = 50 mA				
	TCR4S14DWBG		1.4		300 (Typ.)@I _{OUT} = 50 mA				
TCR4S15WBG	TCR4S15DWBG		1.5		6.0				200 (Typ.)@I _{OUT} = 50 mA
TCR4S16WBG	TCR4S16DWBG		1.6						
TCR4S17WBG	TCR4S17DWBG		1.7						
TCR4S18WBG	TCR4S18DWBG		1.8						
TCR4S19WBG	TCR4S19DWBG		1.9						
TCR4S20WBG	TCR4S20DWBG		2.0						
TCR4S21WBG	TCR4S21DWBG		2.1						
TCR4S22WBG	TCR4S22DWBG		2.2						
TCR4S23WBG	TCR4S23DWBG		2.3						
TCR4S24WBG	TCR4S24DWBG		2.4						
TCR4S25WBG	TCR4S25DWBG		2.5	90 (Typ.)@I _{OUT} = 50 mA	150 (Typ.)@I _{OUT} = 50 mA			30 (Typ.)	
TCR4S26WBG	TCR4S26DWBG		2.6						
TCR4S27WBG	TCR4S27DWBG		2.7						
TCR4S28WBG	TCR4S28DWBG		2.8						
	TCR4S285DWBG		2.85						
TCR4S29WBG	TCR4S29DWBG		2.9						
	TCR4S295DWBG		2.95						
TCR4S30WBG	TCR4S30DWBG	3.0							
TCR4S31WBG	TCR4S31DWBG	3.1							
TCR4S32WBG	TCR4S32DWBG	3.2							
TCR4S33WBG	TCR4S33DWBG	3.3	35 (Typ.)						
TCR4S34WBG	TCR4S34DWBG	3.4							
TCR4S35WBG	TCR4S35DWBG	3.5							
TCR4S36WBG	TCR4S36DWBG	3.6							

■ New product ■ Under development

Typical Performance Characteristics (TCR4S)

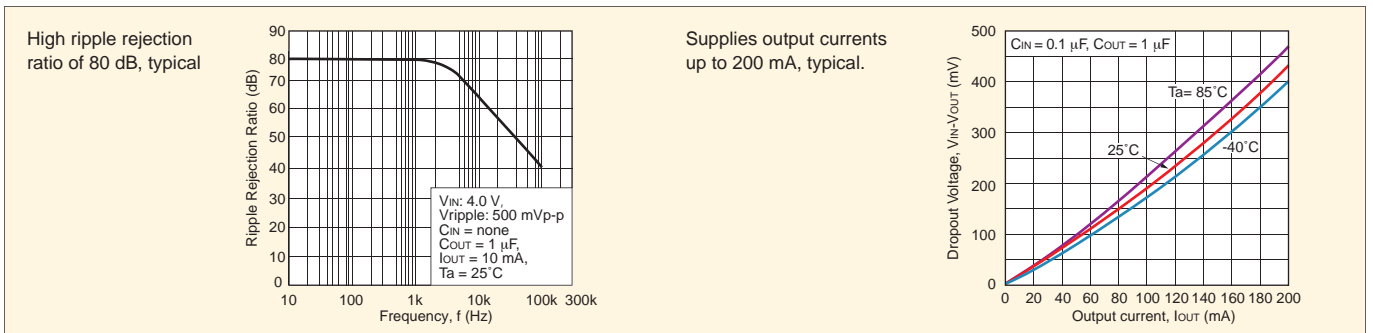

CMOS LDO Regulator Series in the SMV Package

Part Number	Output Current (mA)	Output Voltage (V)	Maximum Input Voltage (V)	Dropout Voltage (mV)	Bias Current (μA)	Ripple Rejection Ratio (dB)	Output Noise Voltage (μVrms)
TCR5SB10A	200	1.0	6.0	350 (Typ.)@I _{OUT} = 50 mA	35 (Typ.)	70 (Typ.) @1 kHz	50 (Typ.)
TCR5SB105A		1.05		310 (Typ.)@I _{OUT} = 50 mA			
TCR5SB11A		1.1		270 (Typ.)@I _{OUT} = 50 mA			
TCR5SB115A		1.15		260 (Typ.)@I _{OUT} = 50 mA			
TCR5SB12A		1.2		230 (Typ.)@I _{OUT} = 50 mA			
TCR5SB125A		1.25		190 (Typ.)@I _{OUT} = 50 mA			
TCR5SB13A		1.3					
TCR5SB14A		1.4					

■ New product

■ CMOS LDO Regulator Series in the SMV and ESV Packages

Part Number		Output Current (mA)	Output Voltage (V)	Maximum Input Voltage (V)	Dropout Voltage (mV)	Bias Current (μA)	Ripple Rejection Ratio (dB)
SMV (SOT-25)(SC-74A)	ESV (SOT-553)						
TCR5SB18A	TCR5SC18FE	150	1.8	6.0	200 (Typ.)@I _{OUT} = 50 mA	32 (Typ.)	70 (Typ.) @1 kHz
TCR5SB19A	TCR5SC19FE		1.9		150 (Typ.)@I _{OUT} = 50 mA		
TCR5SB20A	TCR5SC20FE		2.0		130 (Typ.)@I _{OUT} = 50 mA		
TCR5SB21A	TCR5SC21FE		2.1				
TCR5SB22A	TCR5SC22FE		2.2				
TCR5SB23A	TCR5SC23FE		2.3				
TCR5SB24A	TCR5SC24FE		2.4				
TCR5SB25A	TCR5SC25FE		2.5				
TCR5SB26A	TCR5SC26FE		2.6				
TCR5SB27A	TCR5SC27FE		2.7				
TCR5SB28A	TCR5SC28FE		2.8				
TCR5SB29A	TCR5SC29FE		2.9				
TCR5SB30A	TCR5SC30FE		3.0				
TCR5SB31A	TCR5SC31FE		3.1				
TCR5SB32A	TCR5SC32FE		3.2				
TCR5SB33A	TCR5SC33FE		3.3				
TCR5SB34A	TCR5SC34FE		3.4				
TCR5SB35A	TCR5SC35FE		3.5				
TCR5SB36A	TCR5SC36FE		3.6				
TCR5SB37A			3.7		90 (Typ.)@I _{OUT} = 50 mA		
TCR5SB38A			3.8				
TCR5SB39A			3.9				
TCR5SB40A			4.0				
TCR5SB41A			4.1				
TCR5SB42A			4.2				
TCR5SB43A			4.3				
TCR5SB44A			4.4				
TCR5SB45A			4.5				
TCR5SB46A			4.6				
TCR5SB47A			4.7				
TCR5SB48A			4.8				
TCR5SB49A			4.9				
TCR5SB50A		5.0					

■ High-Ripple-Rejection ratio, Low-Noise, 200-mA Series

■ Features

- High maximum output current: I_{OUT} = 200 mA (max)
- High ripple rejection ratio: R.R = 80 dB (typ.) at f = 1 kHz
- Low output noise voltage: V_{NO} = 30 μVrms (typ.) for 3.0-V-output devices
- Overcurrent protection
- Allows use of ceramic capacitors as the input and output capacitors: C_{IN} = 0.1 μF, C_{OUT} = 1.0 μF
- Small packages:
Available in SMV (SOT-25, SC74A) and UFV packages.

■ Product Lineup

Part Number		Output Current (mA)	Output Voltage (V)	Maximum Input Voltage (V)	Dropout Voltage (mV)	Bias Current (μA)	Ripple Rejection Ratio (dB)	Output Noise Voltage (μVrms)
SMV(SOT-25)(SC-74A)	UFV							
TCR5SB12		200	1.2	6.0	500 (Typ.) @I _{OUT} = 50 mA	40 (Typ.)	80 (Typ.) @1 kHz	25 (Typ.)
TCR5SB15	TCR5SB15U		1.5		150 (Typ.)@I _{OUT} = 50 mA			
TCR5SB16	TCR5SB16U		1.6		130 (Typ.)@I _{OUT} = 50 mA			
TCR5SB17	TCR5SB17U		1.7					
TCR5SB18	TCR5SB18U		1.8					
TCR5SB19	TCR5SB19U		1.9					
TCR5SB20	TCR5SB20U		2.0					
TCR5SB21	TCR5SB21U		2.1					
TCR5SB22	TCR5SB22U		2.2					
TCR5SB23	TCR5SB23U		2.3					
TCR5SB24	TCR5SB24U		2.4					
TCR5SB25	TCR5SB25U		2.5					
TCR5SB26	TCR5SB26U		2.6		90 (Typ.)@I _{OUT} = 50 mA			30 (Typ.)
TCR5SB27	TCR5SB27U		2.7					
TCR5SB28	TCR5SB28U		2.8					
TCR5SB29	TCR5SB29U		2.9					
TCR5SB30	TCR5SB30U		3.0					
TCR5SB31	TCR5SB31U		3.1					
TCR5SB32	TCR5SB32U		3.2					
TCR5SB33	TCR5SB33U		3.3					
TCR5SB34	TCR5SB34U		3.4					
TCR5SB35	TCR5SB35U		3.5					
TCR5SB36	TCR5SB36U		3.6					
TCR5SB37	TCR5SB37U		3.7		85 (Typ.)@I _{OUT} = 50 mA			40 (Typ.)
TCR5SB38	TCR5SB38U		3.8					
TCR5SB39	TCR5SB39U		3.9					
TCR5SB40	TCR5SB40U		4.0					
TCR5SB41	TCR5SB41U		4.1					
TCR5SB42	TCR5SB42U		4.2					
TCR5SB43	TCR5SB43U		4.3					
TCR5SB44	TCR5SB44U		4.4					
TCR5SB45	TCR5SB45U		4.5					
TCR5SB46	TCR5SB46U	4.6						
TCR5SB47	TCR5SB47U	4.7						
TCR5SB48	TCR5SB48U	4.8						
TCR5SB49	TCR5SB49U	4.9						
TCR5SB50	TCR5SB50U	5.0						

Dual-Outputs CMOS Low-Dropout Regulators

Fabricated using the CMOS process, these low-dropout regulators provide dual outputs. The maximum output current is 200 mA and over-current protection circuitry is built-in. Each output voltage can be independently turned on/off via the control pins. They are available in SM6 (SOT-26, SC-74) and UF6 packages. Small ceramic capacitors can be used as input and output capacitors.

Features

- High maximum output current: $I_{OUT} = 200 \text{ mA}$ (max)
- Low dropout voltage: $V_{IN} - V_{OUT} = 200 \text{ mV}$ (max) at $I_{OUT} = 50 \text{ mA}$, 3.3-V output
- Low bias current: $I_b = 60 \mu\text{A}$ (typ.) at $I_{OUT(A)} = 0 \text{ mA}$, $I_{OUT(B)} = 0 \text{ mA}$
- High ripple rejection ratio: R.R = 75 dB(typ.) at $f = 1 \text{ kHz}$
- Overcurrent protection

Application Circuit Example (SM6/UF6)

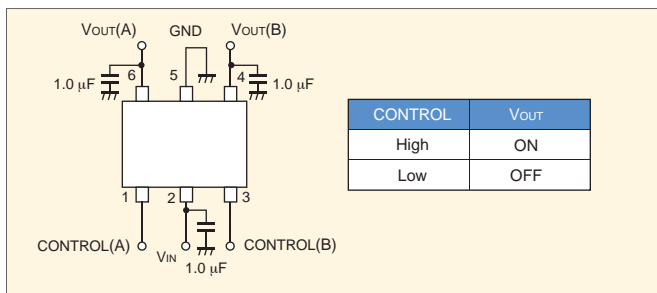

Ripple Rejection Ratio

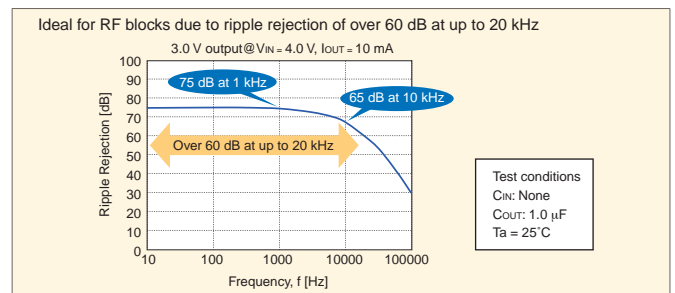

Package Dimensions

Unit: mm

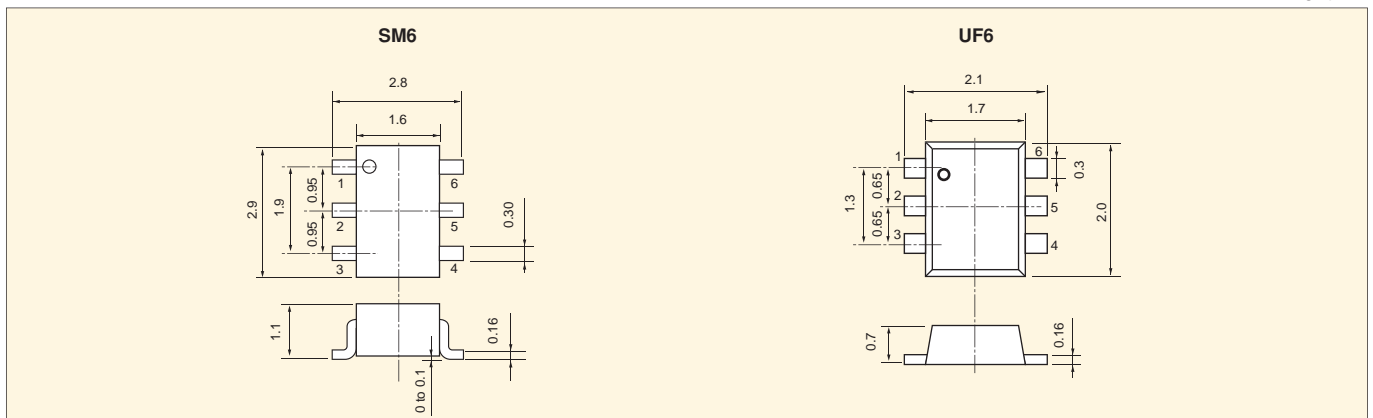

Product Lineup

Part Number	Output Current (mA)	Output Voltage (V) *		Maximum Input Voltage (V)	Dropout Voltage (mV)		Bias Current (μA)	Ripple Rejection Ratio (dB)		
		V _{OUT(A)}	V _{OUT(B)}		V _{OUT(A)}	V _{OUT(B)}				
TCR6DA1525	200	1.5 V	2.5 V	6.0	300 (Typ.)	90 (Typ.)	60 (Typ.)	75 (Typ.)		
TCR6DA1528		1.5 V	2.8 V							
TCR6DA1529		1.5 V	2.9 V							
TCR6DA1530		1.5 V	3.0 V							
TCR6DA1531		1.5 V	3.1 V							
TCR6DA1533		1.5 V	3.3 V							
TCR6DA1825		1.8 V	2.5 V		200 (Typ.)	90 (Typ.)	60 (Typ.)			
TCR6DA1828		1.8 V	2.8 V							
TCR6DA1829		1.8 V	2.9 V							
TCR6DA1830		1.8 V	3.0 V							
TCR6DA1831		1.8 V	3.1 V							
TCR6DA1833		1.8 V	3.3 V							
TCR6DA2530U			2.5 V		3.0 V		90 (Typ.)			

* The V_{OUT(A)} and V_{OUT(B)} voltages of the TCR6DAxxU are the opposite of those shown in the above table.

New Product

4 LDO (Low-Dropout Regulators)

4.2 Bipolar LDO Regulators

These LDO regulator ICs consist of one or two regulators and a control switch in small package. They are suitable for battery-powered applications such as cell phones, portable audio players and personal digital assistants (PDAs).

Single-Output Bipolar Low-Dropout Regulators

Features

- Dropout voltage 130 mV (typ.), 200 mV (max) at 50 mA
- Low noise: 30 μ Vrms (typ.), with a noise bypass capacitor
- High ripple rejection: R.R. = 70 dB (typ. at $f = 1$ kHz)
- On/off control (On at 1.5 V or higher; off at 0.4 V or lower)
- Standby current of 0.1 μ A or less (when off)
- Thermal shutdown and overcurrent protection
- Ceramic capacitors can be used

Application Circuit Example

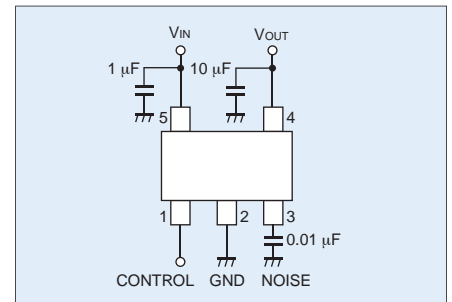

Product Lineup

TAR5SxxU, TAR5SBxx and TAR5Sxx Series

TAR5Sxx TAR5SBxx TAR5SxxU	Output Current (mA)	Output Voltage (V)	Maximum Input Voltage (V)	Ripple Rejection (dB)
15	200	1.5	15	70 (Typ.) @1 kHz
16		1.6		
17		1.7		
18		1.8		
19		1.9		
20		2.0		
21		2.1		
22		2.2		
23		2.3		
24		2.4		
25		2.5		
26		2.6		
27		2.7		
28		2.8		
29		2.9		
30		3.0		
31		3.1		
32		3.2		
33		3.3		
34		3.4		
35		3.5		
36		3.6		
37		3.7		
38		3.8		
39		3.9		
40		4.0		
41		4.1		
42		4.2		
43		4.3		
44		4.4		
45	4.5			
46	4.6			
47	4.7			
48	4.8			
49	4.9			
50	5.0			

TAR5Sxx Series, TAR5SBxx Series

Packaging	Absolute Maximum Ratings	
	Output Current (mA)	Power Dissipation (mW)*
SMV (SC-74A) (SOT-25) Unit: mm	200	380

*: When mounted on a glass epoxy circuit board of 30 mm x 30 mm.
Pad dimension of 50 mm²

TAR5SxxU Series

Packaging	Absolute Maximum Ratings	
	Output Current (mA)	Power Dissipation (mW)*
UFV Unit: mm	200	450

*: When mounted on a glass epoxy circuit board of 30 mm x 30 mm.
Pad dimension of 35 mm²

Dual-Output Bipolar Low-Dropout Regulators

TAR8DxxK Series (Dual-Outputs Regulators with Independent On/Off Control)

■ Features

- Dual-outputs regulator in a small 8-pin package (US8)
- Output voltage can be set in 0.1-V steps, between 1.5 V and 5.0 V. (Semi-custom products)
- Stable operation even with a ceramic output capacitor

■ Typical Characteristics

- Dropout voltage: 120 mV (typ.), 180 mV (max) at 30 mA
- Low noise: 30 μ Vrms (typ.), with a noise bypass capacitor
- High ripple rejection: 70 dB (typ. at $f = 1$ kHz)
- Each channel can be controlled individually.
- Standby current of 1 μ A or less (when off)
- Thermal shutdown and overcurrent protection

■ Application Circuit Example

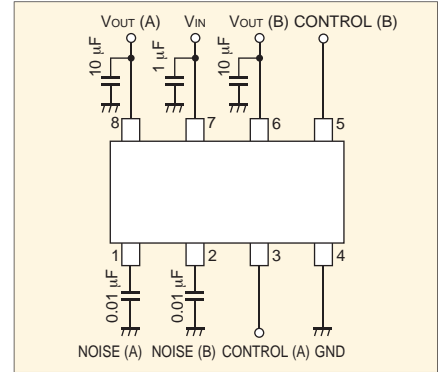

TAR8HxxK Series (Dual-Outputs Regulators)

■ Features

- Dual-outputs regulator in a small 8-pin package (US8)
- Output voltage can be set in 0.1-V steps, between 1.5 V and 5.0 V. (Semi-custom products)
- Stable operation even with a ceramic output capacitor

■ Typical Characteristics

- Dropout voltages
Channel A: 130 mV (typ.), 200 mV (max) at 30 mA
Channel B: 150 mV (typ.), 300 mV (max) at 60 mA
- Low noise: 30 μ Vrms (typ.), with a noise bypass capacitor
- High ripple rejection: 65 dB (typ. at $f = 200$ Hz)
- On/off control (On at 2.2 V or higher, off at 0.4 V or lower)
- Standby current of 10 μ A or less (when off)
- Thermal shutdown and overcurrent protection

■ Application Circuit Example

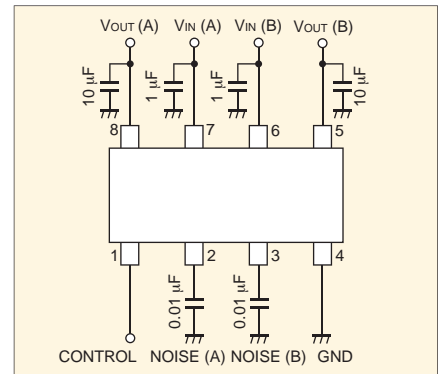

TAR8Dxx Series (Dual-Output Regulators with Independent On/Off Control)

Output voltage can be set in 0.1-V steps between 1.5 V and 5.0 V. (Semi-custom products)

■ Product Lineup

Part Number	Ch	Output Voltage (V)		Maximum Input Voltage (V)	Ripple Rejection (dB)	Absolute Maximum Ratings		Packaging
		Measurement Current (mA)				Output Current (mA)	Power Dissipation (mW)	
TAR8D01K	A	2.5	30	15	70 (Typ.) @1 kHz	100	400	US8
	B	2.8						
TAR8D02K	A	2.0						
	B	2.8						
TAR8D03K	A	2.8						
	B	3.0						
TAR8D04K	A	1.5						
	B	1.5						
TAR8D05K	A	2.8						
	B	2.8						
TAR8D06K	A	2.9						
	B	2.9						
TAR8D07K	A	3.0						
	B	3.0						
TAR8D08K	A	2.8						
	B	2.85						

Usage Precautions

A bypass capacitor should be connected to the NOISE pin for stable operation; the recommended value is 0.0047 μ F or higher.

All devices in this catalog built in over-current protection and only bipolar LDO regulators built in thermal shutdown. These features are not intended to keep the devices within their absolute maximum ratings.

Toshiba recommends that the specific datasheets be checked and that devices always be used within their absolute maximum ratings.

Dual-Output Regulators: TAR8Hxx Series (Dual Outputs)

Output voltage can be set in 0.1-V steps between 1.5 V and 5.0 V. (Semi-custom products)

■ Product Lineup

Part Number	Ch	Output Voltage (V)		Maximum Input Voltage (V)	Ripple Rejection (dB)	Absolute Maximum Ratings		Packaging
		Measurement Current (mA)				Output Current (mA)	Power Dissipation (mW)	
TAR8H01K	A	2.8	12	65 (Typ.) @200 Hz	400	US8		
	B	3.0						
TAR8H02K	A	2.8						
	B	2.8						
TAR8H03K	A	2.5						
	B	2.8						
TAR8H04K	A	2.5						
	B	3.0						
TAR8H05K	A	1.8						
	B	2.8						
TAR8H06K	A	1.5						
	B	2.5						

Digital-Output Magnetic Sensors: TCS10/11 and TCS20 Series

The TCS10SPU/NPU/DPU, TCS10SLU/NLU/DLU, TCS11DLU and TCS20DPR/DLR/DPC/DLC are digital-output magnetic sensors that are switched on and off by the magnetic field of a permanent magnet. The TCS10x and TCS20x magnetic sensors are available with push-pull or open-drain output. These devices are ideal for non-contact open/close sensing for a variety of applications such as cell phones, notebook PCs and electric home appliances.

Features

- Detects the South-Pole, North-Pole or both polarities.
- Push-pull or open-drain output
- Low power consumption
- Package CST6C (ultra-thin)
 - UFV (physically similar to SC-88A)
 - SOT-23F (physically similar to SOT-23)

Typical Characteristics (TCS10/11 Series)

- Supply voltage: 2.3 to 3.6 V
- Average current consumption
 - 5.5 μ A typ. (single detection)
 - 8.5 μ A typ. (double detection)
- Magnetic flux density
 - (Operating point) B_{ON} : 2.5 mT (max)
 - (Releasing point) B_{OFF} : 0.3 mT (min)

Typical Characteristics (TCS20 Series)

- Supply voltage: 2.3 to 3.6 V
- Average current consumption: 7.3 μ A (typ.) at $V_{CC} = 2.3$ V
- Magnetic flux sensitivity:
 - TCS20DPR / DLR
 - (Operating point) B_{ON} : 4.4 mT (max)
 - (Releasing point) B_{OFF} : 0.9 mT (min)
 - TCS20DPC / DLC
 - (Operating point) B_{ON} : 3.8 mT (max)
 - (Releasing point) B_{OFF} : 0.3 mT (max)

Product Lineup

Part Number	Detected Polarity	Output	Magnetic Flux Density	Package
TCS10SPU	S	Push-pull	B_{ON} : 1.8 mT (Typ.) B_{OFF} : 0.8 mT (Typ.)	UFV
TCS10SLU		Open-drain		
TCS11SLU		Inverting output, Open-drain		
TCS10NPU	N	Push-pull		
TCS10NLU		Open-drain		
TCS11NLU		Inverting output, Open-drain		
TCS10DPU	S/N	Push-pull	B_{ON} : 3.4 mT (Typ.) B_{OFF} : 2.0 mT (Typ.)	SOT-23F
TCS10DLU		Open-drain		
TCS11DLU		Inverting output, Open-drain		
TCS20DPR	S/N	Push-pull		
TCS20DLR		Open-drain		
TCS20DPC		Push-pull		
TCS20DLC		Open-drain		

Switching Configuration

Example of South-Pole Detection

Magnetic Flux Density	Output
B_{ON}	V_{OL}
B_{OFF}	$V_{OH}^{(Note)}$

Note: High-impedance state for magnetic sensors with an open-drain output

When the flux density exceeds B_{ON} as the S pole of a magnet moves toward a sensor, its output voltage changes from High to Low.

When the flux density drops below B_{OFF} as the S pole of a magnet moves away from a sensor, its output changes from Low to High.

Application Example

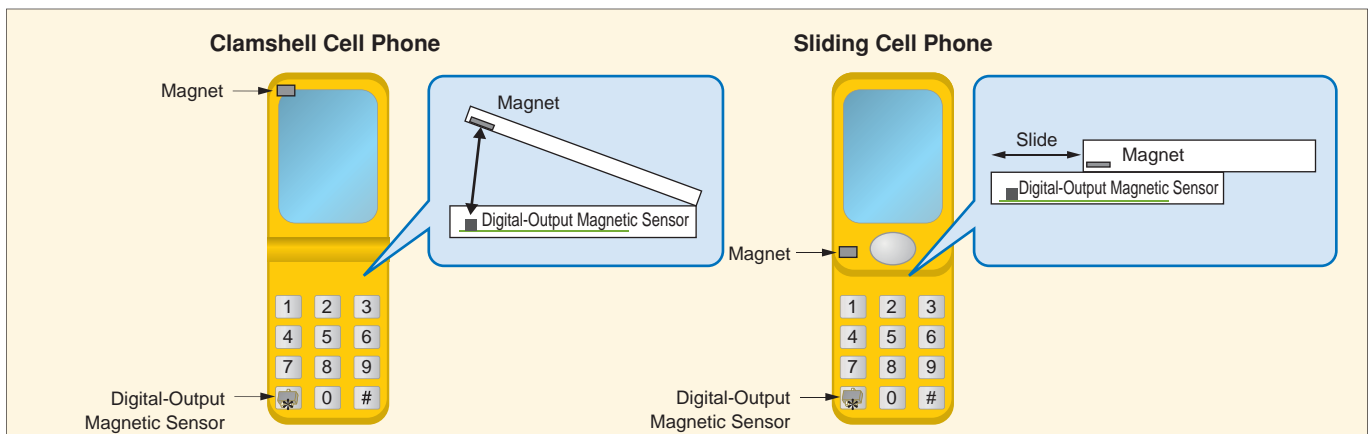

■ Representative Characteristics Curves

<TCS10 Series>

Operating Characteristics (South-Pole Detection)

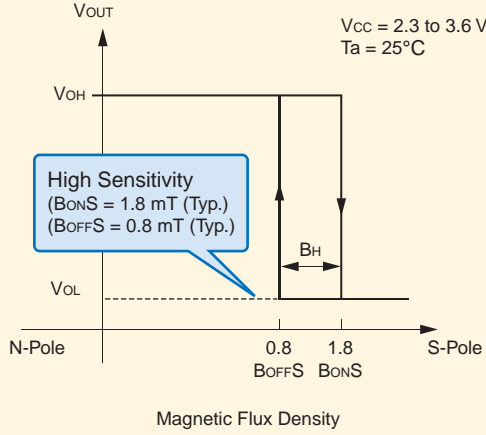

Pulse Current Consumption (South-Pole Detection)

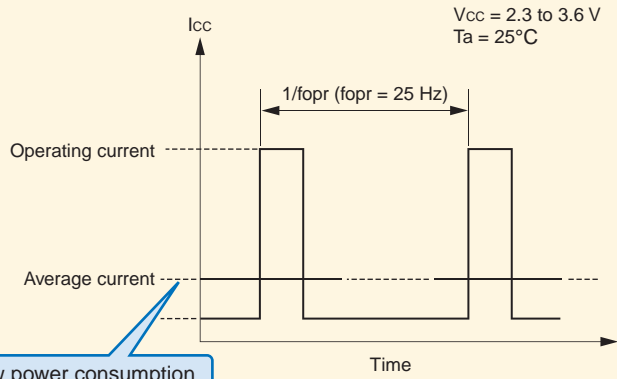

<TCS20 Series>

Operating Characteristics (Double Detection)

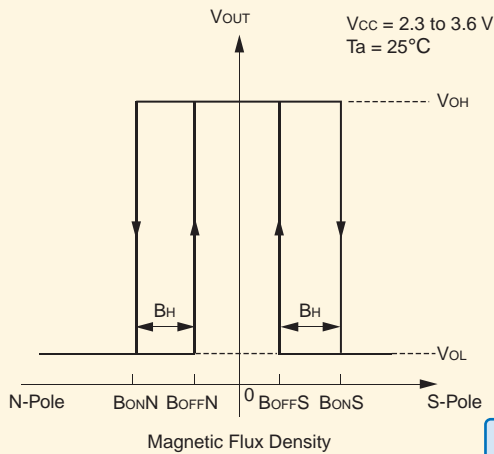

Pulse Current Consumption (Double Detection)

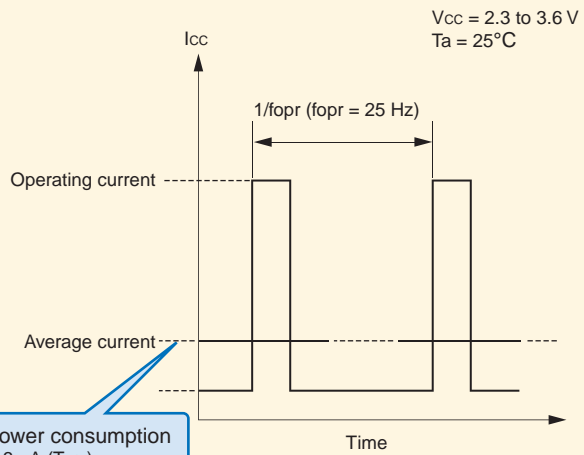

■ Package Dimensions

<UFV>

Unit: mm

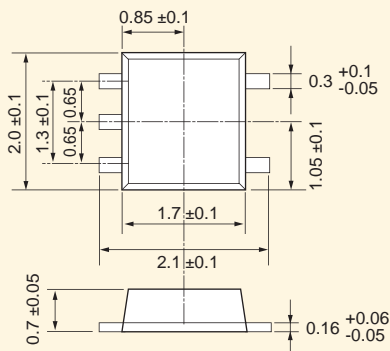

<SOT-23F>

Unit: mm

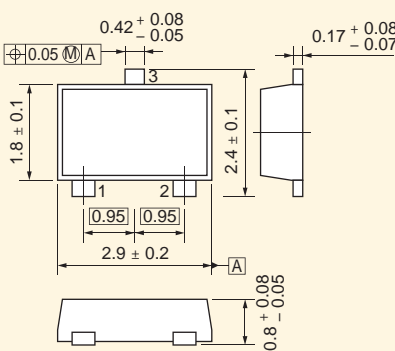

<CST6C>

Unit: mm

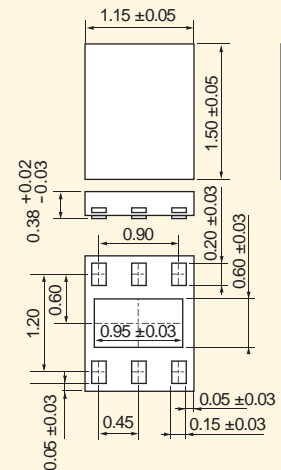

5 Magnetic Sensors

■ Magnetic Sensor Locations (For Reference Only)

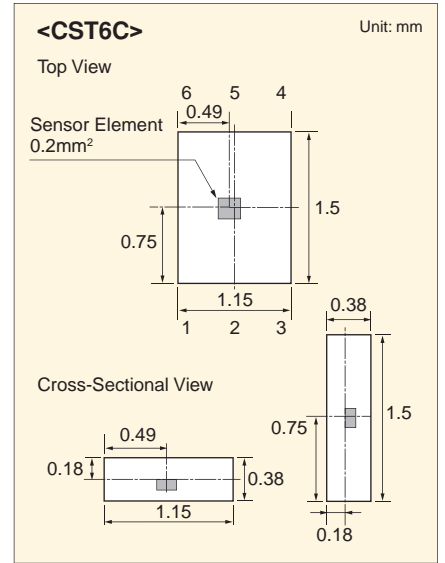
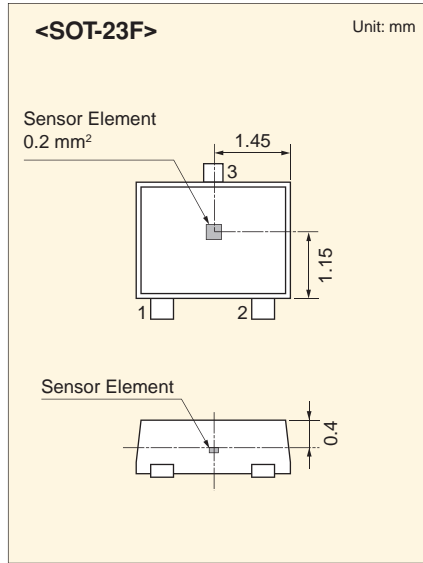
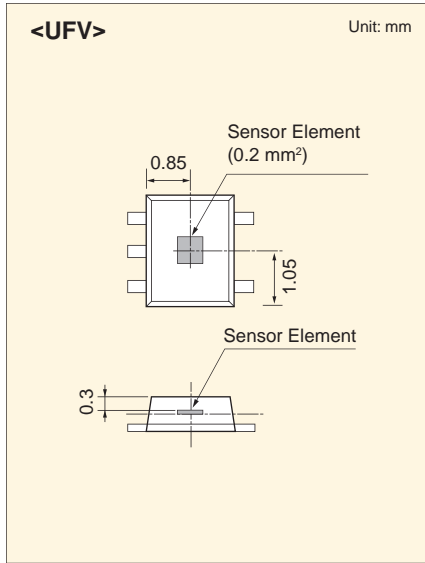

■ Application Circuit Example

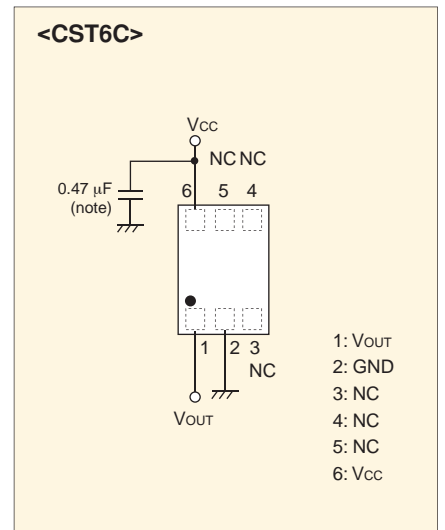
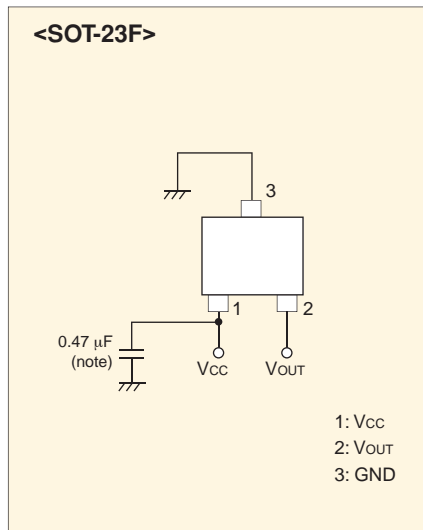
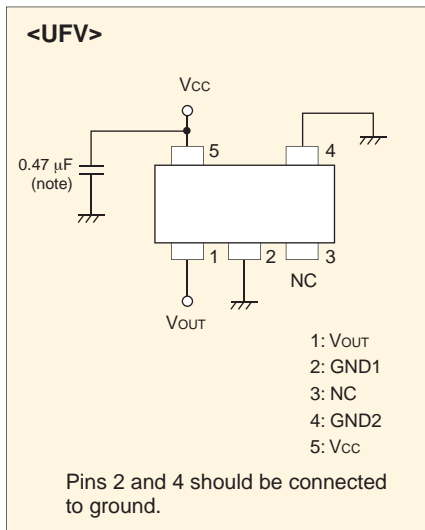

Note: A 0.47 µF capacitor should be connected near the device.
This condition will not guarantee successful operation.
Check the performance through evaluation using the actual application to set the condition.

Low-Ron Analog Switches in a Tiny Package (CST6C): TCFS101FC, TCFS201FC

Key Characteristics (at $V_{CC} = 3.6\text{ V}$, $T_a = 25^\circ\text{C}$)

Characteristic	TCFS101FC (SPST)	TCFS201FC (SPDT)
RON Flatness	0.3 Ω (Typ.)	0.5 Ω (Typ.)
On-Resistance (R_{ON})	1.0 Ω (Typ.)	1.9 Ω (Typ.)
Total Harmonic Distortion (THD)	0.003% (Typ.)	0.005% (Typ.)
Operating Voltage Range (V_{CC})	1.65 to 3.6 V	1.65 to 3.6 V
Maximum Output Current	120 mA	120 mA
Package	CST6C (1.15 x 1.50 x 0.38 mm)	CST6C (1.15 x 1.50 x 0.38 mm)
Pin Assignments (top view)		

Note: SPST = Single Pole, Single Throw, SPDT = Single Pole, Double Throw

Application Example: TCFS201FC (SPDT)

The low on-resistance of the TCFS201FC makes it suitable for audio selector applications.

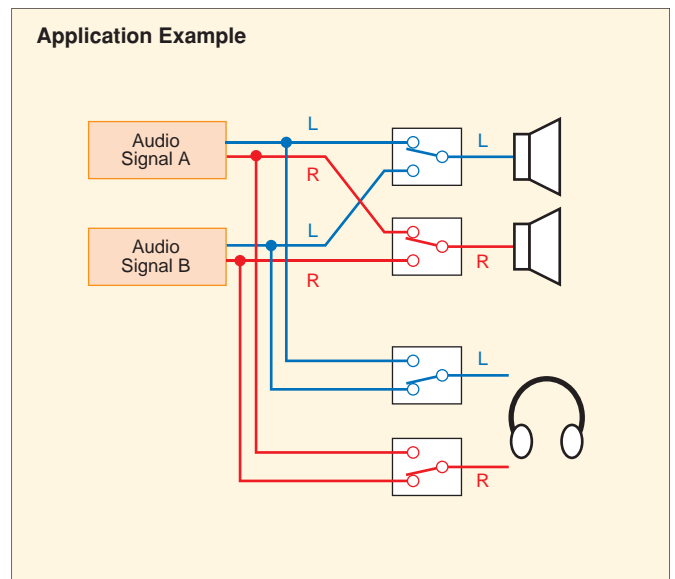
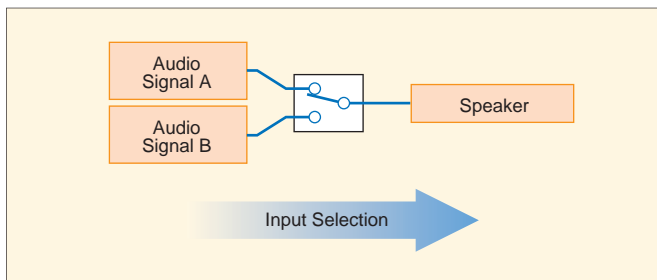
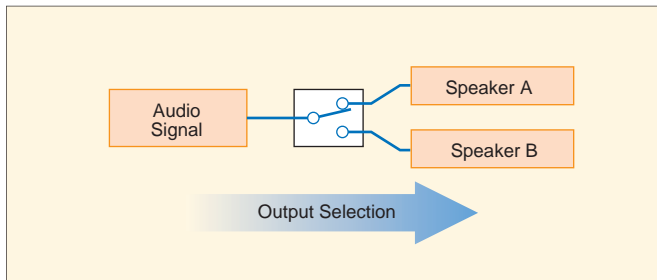

Outline Dimensions of the Ultra-Small CST6C Package with Metal Contacts on the Bottom (1.15 mm x 1.50 mm x 0.38 mm)

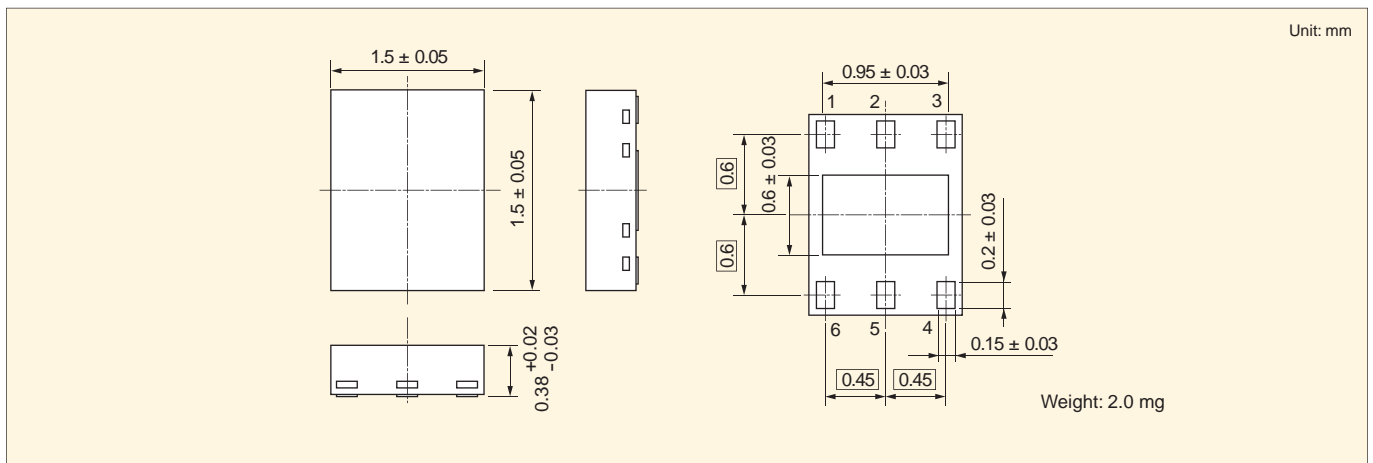

7.1 Low-Noise CMOS Op Amp TC75S63TU New Product

Toshiba has added the TC75S63TU featuring low equivalent input noise voltage to its CMOS op amp portfolio. Housed in a tiny package, it is ideal for applications that amplify a weak signal from a vibration sensor, etc.

■ Features

- Low equivalent input noise voltage: 7.8 nV/ $\sqrt{\text{Hz}}$ typ. at $V_{DD} = 3.3 \text{ V}$, $f = 1 \text{ kHz}$
- Small phase delay: -2.5 degree typ. at $V_{DD} = 3.3 \text{ V}$, $f = 2 \text{ kHz}$
- Small package: UFV (2.0 x 2.1 x 0.7 mm)
- Suited to amplify a weak signal from a vibration sensor, etc.
- Operating voltage range: 2.2 to 5.5 V

■ Electrical Characteristics (at $V_{DD} = 3.3 \text{ V}$, $V_{SS} = \text{GND}$, $T_a = 25^\circ\text{C}$)

Characteristics	Symbol	Test Condition	Min	Typ.	Max	Unit
Common mode input voltage	CMVIN	$R_s = 1 \text{ k}\Omega$, $R_F = 100 \text{ k}\Omega$	0	–	2.4	V
Common mode input signal rejection ratio	CMRR	$V_{IN} = 0 \text{ to } 2.4 \text{ V}$	60	80	–	dB
Supply voltage rejection ratio	SVRR	$V_{DD} = 2.2 \text{ to } 5.5 \text{ V}$	60	80	–	dB
Supply current	I_{DD}	–	–	500	650	μA
Equivalent input noise voltage	V_{NI}	$f = 1 \text{ kHz}$, $AV = 40\text{dB}$, $R_s = 100 \Omega$, $R_F = 10 \text{ k}\Omega$	–	7.8	–	nV/ $\sqrt{\text{Hz}}$
Phase delay	ϕ_D	$f = 2 \text{ kHz}$	–	-2.5	–	degree

■ Equivalent input Noise Voltage (at $V_{DD} = 3.3 \text{ V}$, $V_{SS} = \text{GND}$, $T_a = 25^\circ\text{C}$)

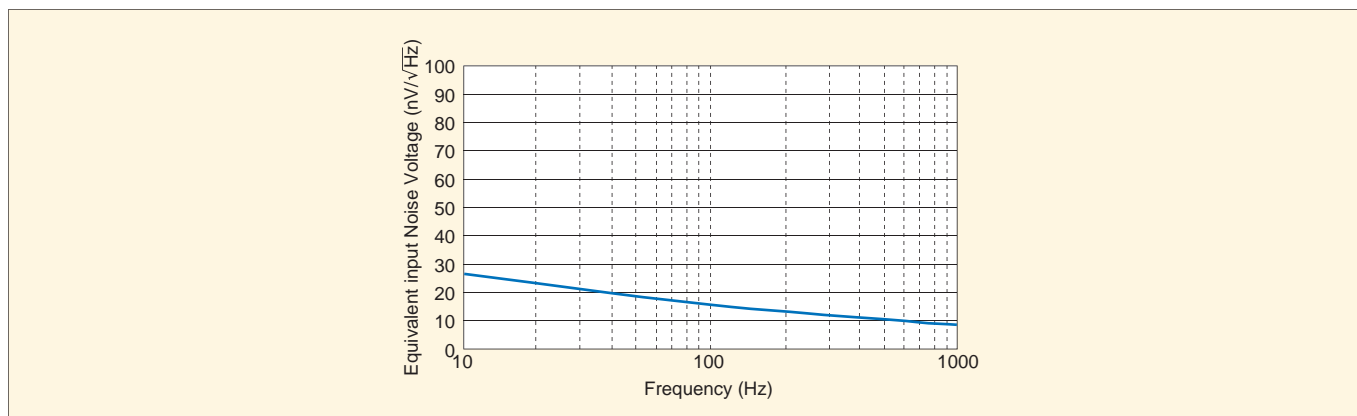

7.2 New Small Package CMOS Op Amp TC75S56FC, TC75S58AFC, TC75S59AFC

CST6C: Ultra-Small Package with Electrodes on the Bottom

Size: 1.15 mm (H) x 1.50 mm (W) x 0.38 mm. Reduction of 67% mounting area of the ESV package.

■ CST6C Package Dimensions

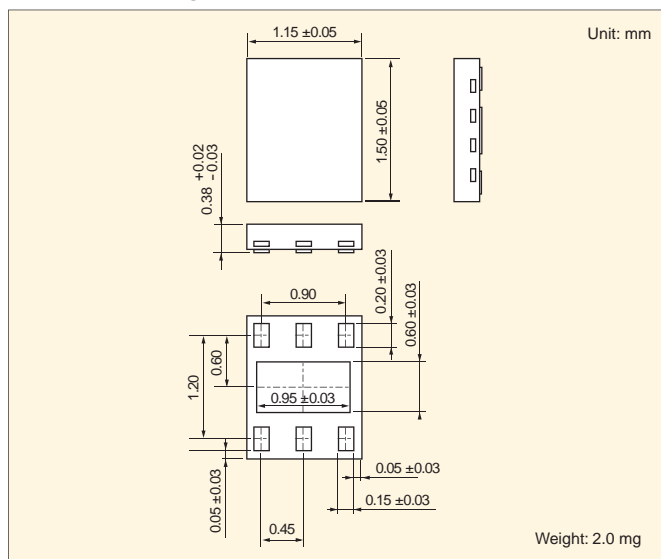

■ Comparators in the CST6C Package

Part Number	Function
TC75S56FC	Ultra-low- I_{DD} comparator ($I_{DD} = 10 \mu\text{A}$)
TC75S58AFC	Open-drain comparator ($I_{DD} = 10 \mu\text{A}$)
TC75S59AFC	Open-drain comparator ($I_{DD} = 100 \mu\text{A}$)

7.3 Open-Drain Comparators TC75S58AFE, TC75S59AFE

Output Power-Down Protection

TC75S58AFE($I_{DD} = 10 \mu\text{A}$)/TC75S59AFE($I_{DD} = 100 \mu\text{A}$)

The TC75S58AFE and TC75S59AFE are new versions of the TC75S58 and TC75S59 respective with output power-down protection.

Features

- Translation to a voltage higher than V_{DD} (see Figure 1)
- Voltage application to the OUT pin allowed even when $V_{DD} = 0\text{ V}$ (see Figure 2)
(Note: The output can tolerate a voltage up to the rated absolute maximum voltage.)

Key Characteristics (at $V_{DD} = 3.0\text{ V}$, $V_{SS} = 0\text{ V}$, $T_a = 25^\circ\text{C}$)

- Operating current: $I_{DD} = 10 \mu\text{A}$ (TC75S58AFE)/ $I_{DD} = 100 \mu\text{A}$ (TC75S59AFE)
- Open-drain output
- Small package: ESV (1.6 mm x 1.6 mm)

Figure 1: Level-Shifting from 1.8 V to 3.6 V

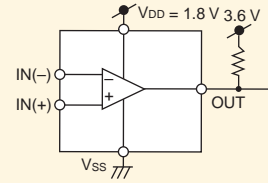
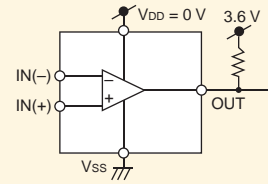

Figure 2: Voltage Application Allowed When $V_{DD} = 0\text{ V}$



7.4 Input and Output Full Range Op Amps TC75S101F/TC75S101FU/TC75S101FE Series

Full-Range Input/Output and Low Input Offset Voltage Version of the Existing TC75S51F/FU TC75S101FU (USV package), TC75S101F (SMV package) and TC75S101FE (ESV package)

Key Characteristics (at $V_{DD} = 3.0\text{ V}$, $V_{SS} = 0\text{ V}$, $T_a = 25^\circ\text{C}$)

- Supply voltage range: 1.5 V to 5.5 V
- Common-mode input voltage range: V_{SS} to V_{DD} (Full-range input)
- Output voltage: $V_{OH} = V_{DD}$ / $V_{OL} = V_{SS}$ (Full-range output)
- Input offset voltage $V_{IO} = 3\text{ mV}$ (max)
- Input bias current $I_I = 0.1\text{ pA}$ (typ.)
- Current consumption: $I_{DD} = 63 \mu\text{A}$ (typ.)
- Push-output

Product Lineup

	Part Number	Package	Marking	Pin Configuration
Single	TC75S101F	SMV (SC-74A, SOT-25)	SJ	
	TC75S101FU	USV (SC-88A, SOT-353)		
	TC75S101FE	ESV		

TC75S101: Common-Mode Input Voltage vs. Input Offset Voltage

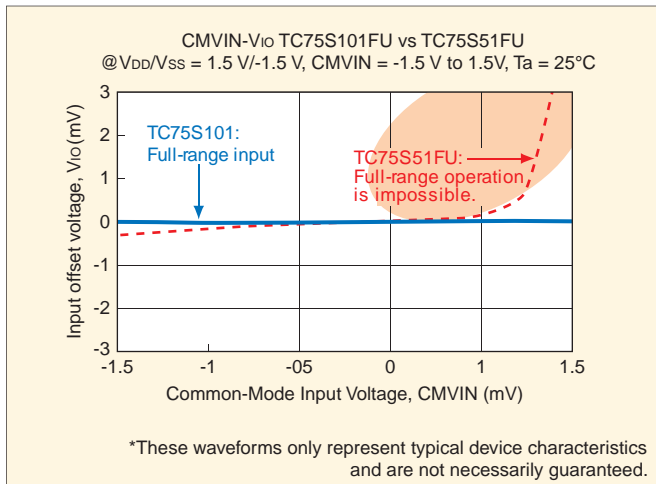

Characteristics Comparisons with Existing Devices

Absolute Maximum Ratings

Characteristic	Symbol	TC75S101FU	TC75S51FU
Power supply voltage	V_{DD}, V_{SS}	$\pm 3.0\text{ V}, 6.0\text{ V}$	$\pm 3.5\text{ V}, 7.0\text{ V}$
Differential input voltage	DVIN	$\pm 6.0\text{ V}$	$\pm 7.0\text{ V}$
Operating supply voltage range	-	$\pm 0.75\text{ V}$ to $\pm 2.75\text{ V}$ or 1.5 V to 5.5 V	-

Electrical Characteristics (at $V_{DD} = 3\text{ V}$, $V_{SS} = \text{GND}$, $T_a = 25^\circ\text{C}$)

Characteristic	Symbol	TC75S101FU	TC75S51FU
Input offset voltage	V_{IO}	$\pm 3\text{ mV}$ (Max)	$\pm 10\text{ mV}$ (Max)
Common-mode input voltage	CMVIN	Full range (V_{SS} to V_{DD})	0 to 2.5 V
Power consumption	I_{DD}	$63 \mu\text{A}$ (Typ.)	$60 \mu\text{A}$ (Typ.)
Input offset voltage	I_{IO}	0.1 pA (Typ.)	1 pA (Typ.)
Input bias current	I_I	0.1 pA (Typ.)	1 pA (Typ.)
Voltage gain (open loop)	G_v	110 dB (Typ.)	70 dB (Typ.)
Common-mode input voltage rejection ratio	CMRR	66 dB (Typ.)	65 dB (Typ.)
Supply voltage rejection ratio	SVRR	90 dB (Typ.)	70 dB (Typ.)

7.5 Product Lineup (CMOS Type)

- The TC75S63TU low-noise op amp is a new addition to our portfolio of op amps.
- The TC75S101F/FU/FE op amp operates over the full input and output ranges.
- The TC75S58AFE/59AFE and TC75S58AFC/59AFC comparators feature output power-down protection.

■ Single Circuit SMV: (F type: SOT-25, SC-74A), USV (FU type: SOT-353, SC-88A), ESV (FE type: SOT-553), CST6C (FC type)

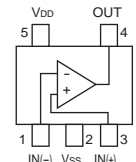
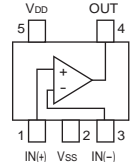
Function	Comparators						Op Amps				
Part Number	TC75S56F TC75S56FU TC75S56FE TC75S56FC	TC75S57F TC75S57FU TC75S57FE	TC75S58F TC75S58FU	TC75S58AFE TC75S58AFC	TC75S59F TC75S59FU	TC75S59AFE TC75S59AFC	TC75S51F TC75S51FU TC75S51FE	TC75S54F TC75S54FU TC75S54FE	TC75S55F TC75S55FU TC75S55FE	TC75S60F TC75S60FU	TC75S101F TC75S101FU TC75S101FE
Marking	TC	TD	TE	TG	TF	TH	SC	SE	SF	SH	SJ
Features	Single/dual power supply; push-pull output; ultra-low current consumption	Single/dual power supply; push-pull output; low current consumption	Single/dual power supply; open-drain output; ultra-low current consumption	Output power-down protection; Single/dual power supply; open-drain output; ultra-low current consumption	Single/dual power supply; open-drain output; low current consumption	Output power-down protection; Single/dual power supply; open-drain output; low current consumption	Single/dual power supply; low-voltage operation; wide dynamic range	Single/dual power supply; low-voltage operation; ultra-low current consumption; wide dynamic range	Single/dual power supply; low-voltage operation; ultra-low current consumption; wide dynamic range	Single/dual power supply; high slew rate; high fT; low-voltage operation; low current consumption	Full-range input/output; low offset voltage; low bias current; single/dual power supply; low-voltage operation
Operating Voltage	1.8 to 7 V / ±0.9 to ±3.5 V						1.5 to 7 V / ±0.75 to ±3.5 V	1.8 to 7 V / ±0.9 to ±3.5 V			1.5 to 5.5 V / ±0.75 to ±2.75 V
Current Dissipation	10 μA	100 μA	10 μA	10 μA	100 μA	100 μA	60 μA	100 μA	10 μA	330 μA	63 μA
*Internal Connections											

■ New product

*The internal connection diagrams only show the general configurations of the circuits

Note: The input pin assignments of the single op amps and comparators differ. The pin assignments of the dual op amps and comparators are identical.

■ Single Circuit: UFV (TU type)

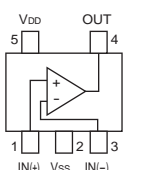
Function	Low-Noise Op Amps	
Part Number	TC75S61TU	TC75S63TU
Marking	SN	SP
Features	Low equivalent input noise voltage Low I _{DD}	Low equivalent input noise voltage Low I _{DD}
Equivalent Input Noise Voltage (Typ. @f=1kHz)	15 nV/√Hz	7.8 nV/√Hz
Operating Voltage	2.2 to 5.5 V	2.2 to 5.5 V
Current Dissipation	230 μA	500 μA
*Internal Connections		



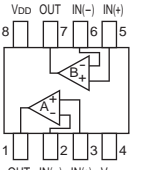
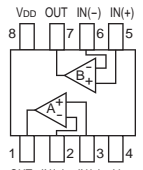



■ Dual Circuit: SM8 (FU type), US8 (FK type)

Function	Comparators				Op Amps			
Part Number	TC75W56FU TC75W56FK	TC75W57FU TC75W57FK	TC75W58FU TC75W58FK	TC75W59FU TC75W59FK	TC75W51FU TC75W51FK	TC75W54FU TC75W54FK	TC75W55FU TC75W55FK	TC75W60FU TC75W60FK
Marking	5W56	5W57	5W58	5W59	5W51	5W54	5W55	5W60
Features	Single/dual power supply; push-pull output; ultra-low current consumption	Single/dual power supply; push-pull output; low current consumption	Single/dual power supply; open-drain output; ultra-low current consumption	Single/dual power supply; open-drain output; low current consumption	Single/dual power supply; low-voltage operation; wide dynamic range	Single/dual power supply; low-voltage operation; ultra-low current consumption; wide dynamic range	Single/dual power supply; low-voltage operation; ultra-low current consumption; wide dynamic range	Single/dual power supply; high slew rate; high fT; low-voltage operation; low current consumption
Operating Voltage	1.8 to 7 V / ±0.9 to ±3.5 V				1.5 to 7 V / ±0.75 to ±3.5 V	1.8 to 7 V / ±0.9 to ±3.5 V		
Current Dissipation	20 μA	200 μA	20 μA	200 μA	120 μA	200 μA	20 μA	660 μA
*Internal Connections								

*The internal connection diagrams only show the general configurations of the circuits

Unit: mm

■ Packaging

Toshiba Package Name	ESV (SOT-553)	USV (SOT-353, SC-88A)	UFV	SMV (SOT-25, SC-74A)	CST6C	US8 (SOT-765)	SM8 (SOT-505)
Package Dimensions							

Photos are real size.

7.6 Product Lineup (Bipolar Type)

Single Circuit: SMV (F type SOT-25, SC-74A)

Function	Comparators	Op Amps	
Part Number	TA75S393F	TA75S01F	TA75S558F
Marking	TA	SA	SB
Features	Single/dual power supply; open-collector output	Single/dual power supply; unity gain capability	Dual power supply
Operating Voltage	2 to 36 V/ ±1 to ±18 V	3 to 12 V/ ±1.5 to ±6 V	±4 to ±18 V
Power Dissipation	0.4 mA	0.4 mA	2.5 mA
Equivalent Products	TA75393 (LM393) (LM2903)	TA75358 (LM358) (LM2804)	TA75558 (4558)
*Internal Connections			

Dual Circuit: SM8 (FU type)

Function	Comparators	Op Amps	
Part Number	TA75W393FU	TA75W01FU	TA75W558FU
Marking	5W393	5W01	5W558
Features	Single/dual power supply; open-collector output	Single/dual power supply; unity gain capability	Dual power supply
Operating Voltage	2 to 36 V/ ±1 to ±18 V	3 to 12 V/ ±1.5 to ±6 V	±4 to ±18 V
Power Dissipation	0.8 mA	0.7 mA	4 mA
Equivalent Products	TA75393 (LM393) (LM2903)	TA75358 (LM358) (LM2804)	TA75558 (4558)
*Internal Connections			

*The internal connection diagrams only show the general configurations of the circuits.

Note: The input pin assignments of the single op amps and comparators differ. The pin assignments of the dual op amps and comparators are identical.

Comparisons of CMOS and Bipolar Op Amp Characteristics

Toshiba offers ultra-small op amps in CMOS and bipolar technology, each of which offers particular characteristics.

The CMOS op amp series was specifically designed for low-voltage operation and low power supply current.

Therefore, compared to the bipolar op amps, the CMOS op amps can substantially reduce power dissipation.

The following table compares the principal characteristics of Toshiba's representative bipolar and CMOS op amps.

Characteristic	CMOS Op Amps		Bipolar Op Amps
	TC75S54F	TC75S55F	TA75S01F
Operating supply voltage	1.8 to 7.0 V	1.8 to 7.0 V	3.0 to 12.0 V
Power supply current (Typ.)	100 μ A ($V_{DD} = 3$ V) 80 μ A ($V_{DD} = 1.8$ V)	10 μ A ($V_{DD} = 3$ V) 8 μ A ($V_{DD} = 1.8$ V)	400 μ A ($V_{CC} = 5$ V)
Input bias current (Typ.)	1 pA ($V_{DD} = 3$ V)	1 pA ($V_{DD} = 3$ V)	45 nA ($V_{CC} = 5$ V)
Maximum output voltage	$V_{DD} - 0.1$ V ($V_{DD} = 3$ V, $R_L = 100$ k Ω)	$V_{DD} - 0.1$ V ($V_{DD} = 3$ V, $R_L = 1$ M Ω)	3.4 V ($V_{CC} = 5$ V, $R_L = 2$ k Ω)
Source current (Typ.)	200 μ A ($V_{DD} = 3$ V) 160 μ A ($V_{DD} = 1.8$ V)	20 μ A ($V_{DD} = 3$ V) 16 μ A ($V_{DD} = 1.8$ V)	40 mA ($V_{CC} = 5$ V)
Sink current (Typ.)	700 μ A ($V_{DD} = 3$ V) 600 μ A ($V_{DD} = 1.8$ V)	450 μ A ($V_{DD} = 3$ V) 400 μ A ($V_{DD} = 1.8$ V)	20 mA ($V_{CC} = 5$ V)

8

Small-Signal Diodes

8.1 Switching Diodes

The internal connection diagrams only show the general configurations of the circuits.

Electrical Characteristics (Ta = 25°C)																						
V _R (V)	I _o (mA)	t _{rr} (ns)	CST2	fSC	ESC (SOD-523)	USC (SOD-323)	CST3	VESM (SOT-723)	SSM (SOT-416, SC-75)	USM (SOT-323, SC-70)	S-Mini (SOT-346, SC-59)	USQ (SOT-343)	SMQ (SOT-24, SC-61)	ESV (SOT-553)	USV (SOT-353)	SMV (SOT-25, SC-74A)	ES6 (SOT-563)	US6 (SOT-363, SC-88)	SM6 (SOT-26, SC-74)			
30	100	—										1SS307										
80	100	—								1SS412	1SS379											
80	100	1.6 Typ.							1SS360	1SS300	1SS181				HN4D01JU	1SS308	HN1D01FE	HN1D01FU	HN1D01F			
80	100	1.6 Typ.					1SS361CT	1SS361FV	1SS361	1SS301	1SS184				HN4D02JU	1SS309	HN1D02FE	HN1D02FU	HN1D02F			
80	100 (80)	1.6 Typ.						1SS362FV	(1SS362)	1SS302	1SS226								HN1D04FU			
80	100 (80)	1.6 Typ.	1SS387CT		1SS387	1SS352						1SS193			HN2D01JE				(HN2D01FU)	(HN2D01F)		
				1SS427								1SS196	1SS382	1SS272							(HN2D02FU)	
												1SS187										
												1SS190										
80	100	1.6 Typ.																	HN1D03FU	HN1D03F		
80	200	7.0 Typ.									1SS336											
80	200	6.0 Typ.									1SS337											
200	100	30 Typ.				1SS403				1SS370	1SS250		1SS306									
400	100	500 Typ.								1SS397	1SS311		1SS399							HN2D03F		
400	100	500 Typ.								1SS398												

8.2

Schottky Barrier Diodes (SBDs) in a 2-pin Package

The internal connection diagrams only show the general configurations of the circuits.

























Features	Absolute Maximum Ratings		Electrical Characteristics (Ta = 25°C)					SC2	CST2	CST2B	fSC	ESC (SOD-523)	USC (SOD-323)
	VR (V)	Io (mA)	VF (V)			IR (μA)							
			Typ.	Max.	@If (mA)	Max.	@VR (V)						
Low-VF	10	100	0.23	0.3	5	20	10					1SS389	1SS367
			100	0.23	—	5	20	10		1SS416CT		1SS416	
	0.38	0.5		100	50	30		DSF01S30SC					
	—	0.3		10	7	10			CTS521 DSF521CT		CES521	CUS521	
	30	200	0.45	0.5	200	30	30			CBS05F30			CUS05F30
								500	0.38	0.45	500	50	30
		700	0.39	0.45	700	50	30					CUS08F30	
		800	0.4	0.45	800	50	30					CUS10F30	
		1000	0.43	0.5	1000	50	30						
		20	50	0.33	—	1	0.5	20			1SS413	1SS405	1SS406
Low-IR	30	100	0.37	0.5	10	0.35	10	DSR01S30SC					
			30	200	0.52	0.6	200	5	30	CTS520 DSR520CT		CES520	CUS520
Standard	40	100	0.54	0.6	100	5	40					1SS388	1SS357
			40	100	0.36	—	10	5	40	1SS417CT		1SS417	
High-Io, Low-VF	20	200	0.23	—	5	50	20					1SS424	
			0.42	0.5	200	20	10					1SS421	
	30	200	0.22	—	5	20	10						
			0.44	0.5	200	30	30						
	30	200	0.36	—	5	5	30		1SS420CT			1SS420	
			0.52	0.6	200								
20	300	0.16	—	1	50	20						1SS404	
			0.22	—	10								
			0.38	0.45	300								

 New product







8.2

Schottky Barrier Diodes (SBDs) in a Package with 3 to 6 Pins

The internal connection diagrams only show the general configurations of the circuits.

Features	Absolute Maximum Ratings		Electrical Characteristics (Ta = 25°C)											
	VR (V)	Io (mA)	VF (V)			IR (µA)			VESM (SOT-723)	SSM (SOT-416, SC-75)	USM (SOT-323, SC-70)	S-Mini (SOT-346, SC-59)	TESQ	USQ (SOT-343)
			Typ.	Max	@If (mA)	Max	@VR (V)							
Low-VF	10	100	0.23	0.3	5	20	10							
			0.35	0.5	100									
	30	100	0.23	—	5	20	10							
			0.38	0.5	100	50	30							
		200	—	0.3	10	7	10							
			500	0.45	0.5	200	30	30						
Low-Ir, High-speed	20	50	0.33	—	1	0.5	20							
			0.38	—	5									
Low-Ir	10	50	0.63	1	100	0.5	10							
			30	100	0.37	0.5	10	0.35	10					
			30	200	0.52	0.6	200	5	30					
			30	500	0.5	0.55	500	5	30					
Improved VF-Ir tradeoff	30	700	0.39	0.45	700	50	30							
	30	700	0.5	0.55	700	5	30							
Standard	40	100	0.54	0.6	100	5	40							
														
	40	100	0.36	—	10	5	40							
High-Io, Low-VF	20	200	0.23	—	5	50	20							
			0.42	0.5	200									
	30	200	0.22	—	5	20	10							
			0.44	0.5	200	30	30							
	30	200	0.36	—	5	5	30							
			0.52	0.6	200									
20	300	0.16	—	1	50	20								
		0.22	—	10										
		0.38	0.45	300										

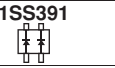
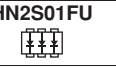
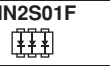
The internal connection diagrams only show the general configurations of the circuits.

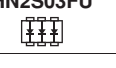
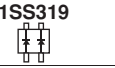
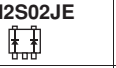
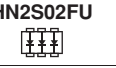
Features	Absolute Maximum Ratings		Electrical Characteristics (Ta = 25°C)									
	VR (V)	Io (mA)	VF (V)			IR (µA)		SMQ (SOT-24, SC-61)	ESV (SOT-553)	ES6 (SOT-563)	US6 (SOT-363, SC-88)	SM6 (SOT-26, SC-74)
			Typ.	Max	@If (mA)	Max	@VR (V)					
Low-VF	10	100	0.23	0.3	5	20	10					
			0.35	0.5	100							
	30	100	0.23	-	5	20	10					
			0.38	0.5	100	50	30					
			-	0.3	10	7	10					
			200	0.45	0.5	200	30					
500	0.4	0.45	500	50	30							
Low-Ir, High-speed	20	50	0.33	-	1	0.5	20					
			0.38	-	5							
			0.50	0.55	50							
Low-Ir	10	50	0.63	1	100	0.5	10					
	30	100	0.37	0.5	10	0.35	10					
	30	200	0.52	0.6	200	5	30					
	30	500	0.5	0.55	500	5	30					
Improved VF-Ir tradeoff	30	700	0.39	0.45	700	50	30					
	30	700	0.5	0.55	700	5	30					
Standard	40	100	0.54	0.6	100	5	40					
			0.36	-	10	5	40					
	0.56	0.62	100									
High-Io, Low-VF	20	200	0.23	-	5	50	20					
			0.42	0.5	200							
	30	200	0.22	-	5	20	10					
			0.44	0.5	200	30	30					
	30	200	0.36	-	5	5	30					
			0.52	0.6	200							
	20	300	0.16	-	1	50	20					
0.22			-	10								
			0.38	0.45	300							

8.3 New Product Information

Schottky Barrier Diodes with an Improved V_F - I_R Tradeoff

■ Features

- Low leakage current and low forward voltage due to the use of a new circuit configuration
- High withstand voltage and large current

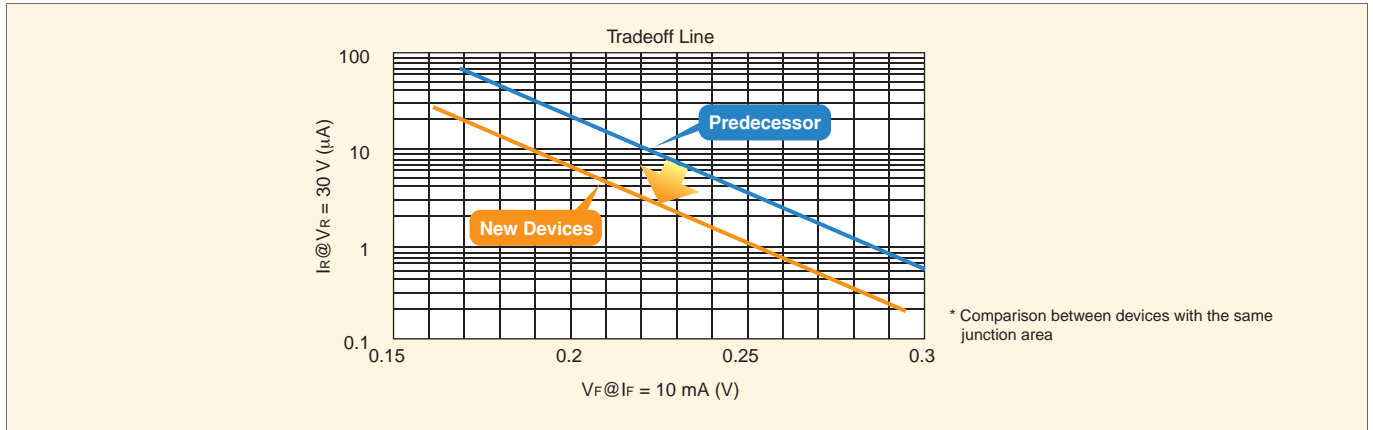

■ Product Lineup

Part number	Absolute Maximum Ratings		Electrical characteristics					Package
	V_R (V)	I_o (mA)	V_F (V)			I_R (μ A)		
			Typ.	Max	@ I_F (mA)	Max	@ V_R (V)	
CUS05F30	30	500	0.38	0.45	500	50	30	USC (SOD-323)
CBS05F30	30	500	0.38	0.45	500	50	30	CST2B
CUS08F30	30	800	0.4	0.45	800	50	30	USC (SOD-323)
CUS10F30	30	1000	0.43	0.5	1000	50	30	USC (SOD-323)

■ New product

■ Package Dimensions

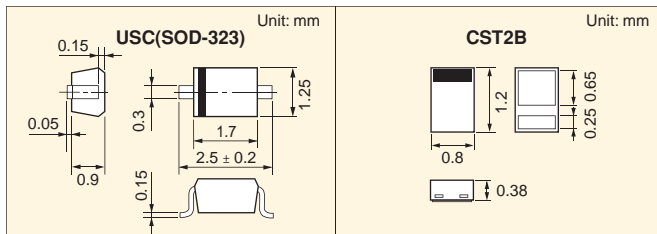

■ Land Pattern Example

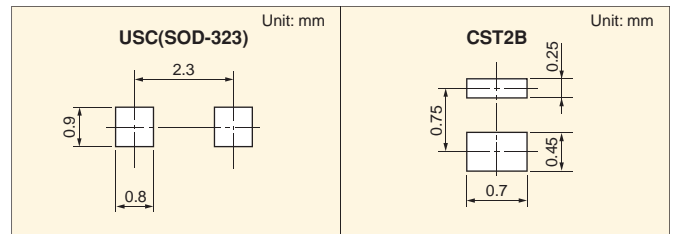

For reference only. Be sure to verify device mountability.

■ Typical Characteristics (CUS10F30)

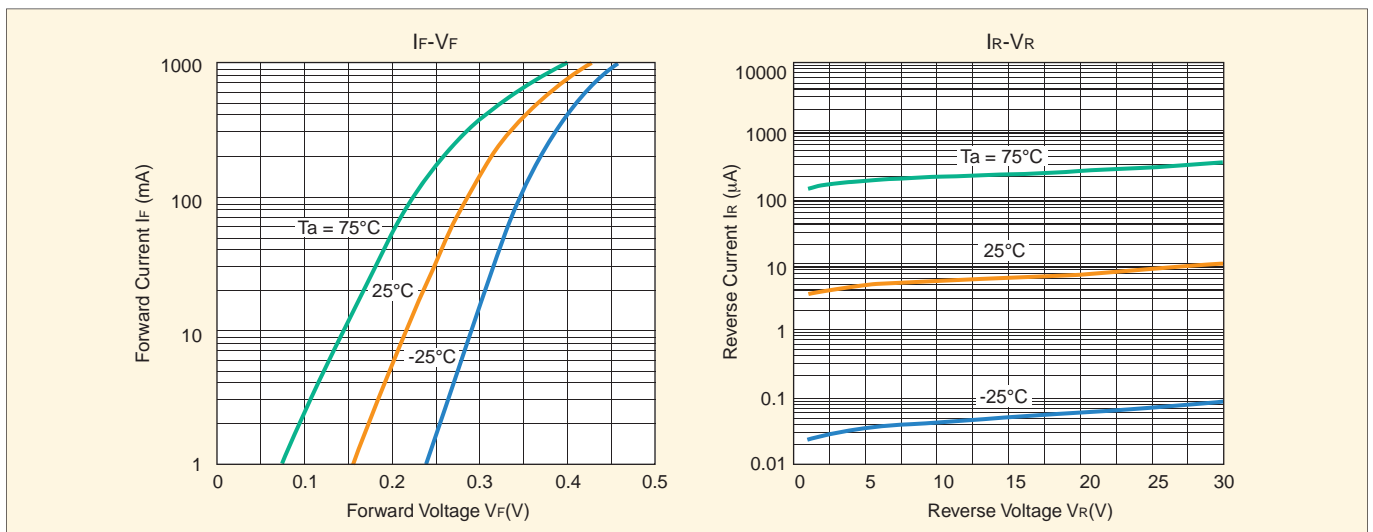

*These waveforms only represent typical device characteristics and are not necessarily guaranteed.

8.4 ESD-Protection Diodes

ESD-protection diodes are designed to absorb electrostatic discharge (ESD) energy that is introduced from I/O ports and travels through the connector onto the system board. The ESD-protection diodes thus provide protection against ESD-induced system malfunction and/or damage to ICs.

System Interface Protection

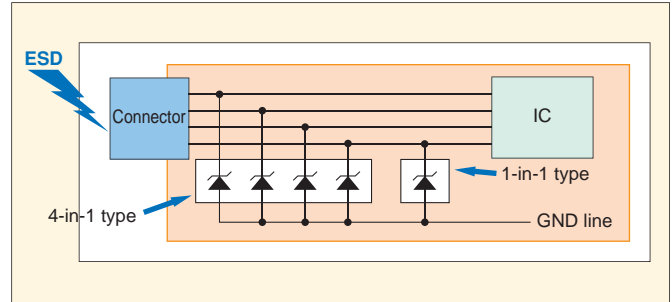

ESD Clamping Performance

Toshiba's ESD-protection diodes are specifically designed for suppression of ESD-induced transients to protect against system malfunction and/or damage to ESD-sensitive ICs

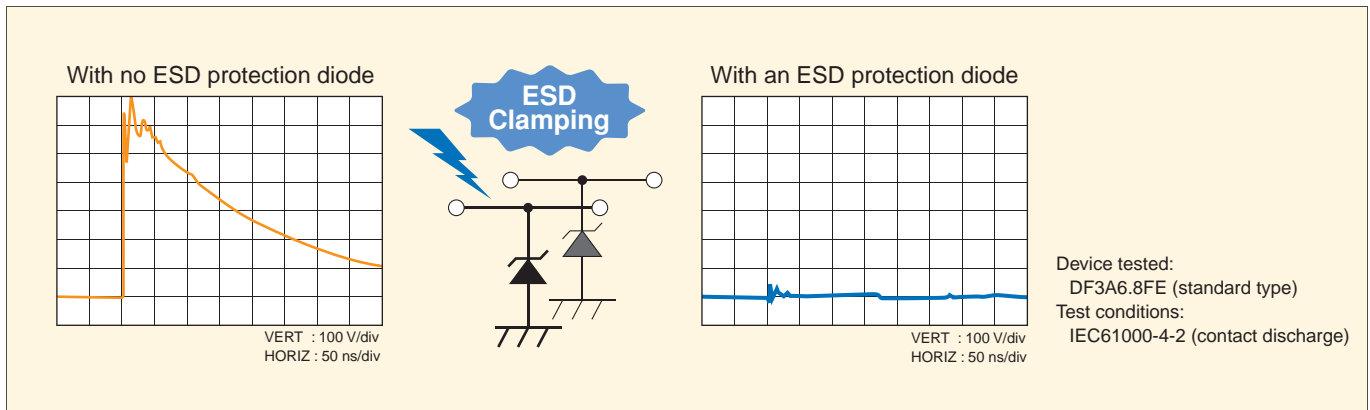

The above graphs are provided for reference only and show the typical ESD-limiting performance of 6.8-V diodes.

ESD Protection Diode Selection Guide

Toshiba offers a wide range of ESD protection diodes suitable for various applications.

Signal Speed	Signal Frequency		ESD Protection Level (kV) (IEC 61000-4-2, Contact Discharge)	
	Frequency Range	Diode Type	ESD Protection Level	ESD Protection Level
HDMI RF antennas	500 MHz – 10 GHz	Extreme High Speed Type	±8 kV	±8 kV
USB 2.0 High-speed memory	10 MHz – 500 MHz	Ultra High Speed Type	±8 kV	±8 kV
USB 1.1 SIM cards	500 KHz – 10 MHz	Super High Speed Type	±8 kV	±8 kV
Interfaces	100 KHz – 500 KHz	High Speed Type	±25 kV	±25 kV
Audio lines General-purpose power supplies	1 KHz – 100 KHz	Standard Type	±30 kV	±30 kV

Standard Type

Single			V _Z (V)	I _R (μA)		C _T (pF)		ESD Immunity (IEC 61000-4-2, Contact Discharge) Min	
CST2	fSC	USC		Typ.	@I _Z (mA)	Max	@V _R (V)		Typ.
-	DF2S4.7FS	-	4.7	5	5	1	51	0	±30 kV
-	DF2S5.1FS	-	5.1		-	-	-	-	
DF2S5.6CT	DF2S5.6FS	-	5.6		1	3.5	40	0	
DF2S6.2CT	DF2S6.2FS	-	6.2		2.5	5	32	0	
DF2S6.8CT	DF2S6.8FS	-	6.8		0.5	5	25	0	
DF2S8.2CT	DF2S8.2FS	-	8.2		0.5	6.5	20	0	
-	DF2S10FS	-	10		0.5	8	16	0	
-	DF2S12FS	DF2S12FU	12		0.05	9	15	0	±20 kV
DF2S16CT	DF2S16FS	-	16		0.5	12	10	0	±12 kV
DF2S18CT	-	-	18		0.5	14	10	0	
DF2S20CT	DF2S20FS	-	20		0.5	15	9.0	0	
DF2S24CT	DF2S24FS	-	24		0.5	19	8.5	0	±10 kV
DF2S30CT	DF2S30FS	-	30		2	0.5	23	7.0	0

Single SC2	V _Z (V)		I _R Max (μA)		C _T (pF)		ESD Immunity (IEC 61000-4-2, Contact Discharge) Min
	Typ.	@I _Z (mA)	Max	@V _R (V)	Typ.	@V _R (V)	
DF2S3.6SC	3.6	5	10	1	-	0	±8 kV
DF2S5.1SC	5.1		1	3.5	25	0	
DF2S5.6SC	5.6		1	3.5	-	0	
DF2S6.2SC	6.2		1	5	16	0	
DF2S6.8SC	6.8		0.5	5	15	0	
DF2S8.2SC	8.2		0.5	6.5	10	0	

New product Under development

2-in-1				4-in-1					V _Z (V)	I _R * (μA)		C _T (pF)		ESD Immunity (IEC 61000-4-2, Contact Discharge) Min	
CST3	VESM (SOT-723)	USM (SOT-323)	S-Mini (SOT-346)	ESV (SOT-553)	USV (SOT-353)	SMV (SOT-25)	US6 (SOT-363)	US8		Typ.	@I _Z (mA)	Max	@V _R (V)		Typ.
DF3A3.3CT	DF3A3.3FV	DF3A3.3FU	-	DF5A3.3JE	DF5A3.3FU	DF5A3.3F			3.3	5	20	1.0	115	0	±30 kV
DF3A3.6CT	DF3A3.6FV	DF3A3.6FU	-	DF5A3.6JE	DF5A3.6FU	DF5A3.6F			3.6	5	10	1.0	110	0	
-	-	DF3A4.3FU	-	-	-	-			4.3	5	10	1.8	100	0	
DF3A5.6CT	DF3A5.6FV	DF3A5.6FU	DF3A5.6F	DF5A5.6JE	DF5A5.6FU	DF5A5.6F		DF8A5.6FK	5.6	5	1	2.5	65	0	
DF3A6.2CT	DF3A6.2FV	DF3A6.2FU	DF3A6.2F	DF5A6.2JE	DF5A6.2FU	DF5A6.2F		DF8A6.2FK	6.2	5	1	3.0	55	0	
DF3A6.8CT	DF3A6.8FV	DF3A6.8FU	DF3A6.8F	DF5A6.8JE	DF5A6.8FU	DF5A6.8F	DF6A6.8FU	DF8A6.8FK	6.8	5	0.5	5.0	45	0	±20 kV
-	-	-	-	-	DF5A12FU	-			12	5	0.05	9	26	0	

*: DF3A 3.3V 100 μA at 1.5 V, DF3A 3.6V 100 μA at 1.8 V

The internal connection diagrams only show the general configurations of the circuits

High-Speed Type

4-in-1		V _Z (V)	I _R (μ A)		C _T (pF)		ESD Immunity (IEC 61000-4-2, Contact Discharge) Min	
ESV (SOT-553)	USV (SOT-353)		@I _Z (mA)	Max	@V _R (V)	@V _R (V)		
								Typ.
DF5A3.6CJE	DF5A3.6CFU	3.6	5	100	1.8	52	0	±30 kV
DF5A5.6CJE	DF5A5.6CFU	5.6	5	1	3.5	29	0	
DF5A6.2CJE	DF5A6.2CFU	6.2	5	1	3	25	0	
DF5A6.8CJE	DF5A6.8CFU	6.8	5	0.5	5	23	0	±25 kV

The internal connection diagrams only show the general configurations of the circuits

5-in-1		V _Z (V)	I _R (μ A)		C _T (pF)		ESD Immunity (IEC 61000-4-2, Contact Discharge) Min	
US6 (SOT-363)	CST6F		@I _Z (mA)	Max	@V _R (V)	@V _R (V)		
								Typ.
DF7A5.6CFU	—	5.6	5	1	2.5	34	0	±30 kV
DF7A6.2CFU	DF7A6.2CTF	6.2	5	1	3	28	0	
DF7A6.8CFU	—	6.8	5	0.5	5	26	0	±25 kV

The internal connection diagrams only show the general configurations of the circuits

Super-High-Speed Type

2-in-1		4-in-1				V _Z (V)	I _R (μ A)		C _T (pF)		ESD Immunity (IEC 61000-4-2, Contact Discharge) Min	
CST3	VESM (SOT-723)	USM (SOT-323)	ESV (SOT-553)	USV (SOT-353)	SMV (SOT-25)		@I _Z (mA)	Max	@V _R (V)	@V _R (V)		
												Typ.
—	DF3A5.6LFV	DF3A5.6LFU	DF5A5.6LJE	DF5A5.6LFU	—	5.6	5	1.0	3.5	8	0	±8 kV
—	DF3A6.2LFV	DF3A6.2LFU	DF5A6.2LJE	DF5A6.2LFU	—	6.2	5	2.5	5.0	6.5	0	
DF3A6.8LCT	DF3A6.8LFV	DF3A6.8LFU	DF5A6.8LJE	DF5A6.8LFU	DF5A6.8LF	6.8	5	0.5	5.0	6	0	

New product

The internal connection diagrams only show the general configurations of the circuits

Ultra-High-Speed Type

Single		2-in-1		V _Z (V)	I _R (μ A)		C _T (pF)		ESD Immunity (IEC 61000-4-2, Contact Discharge) Min	
CST2	fSC	USM			@I _Z (mA)	Max	@V _R (V)	@V _R (V)		
			Min							Typ.
DF2S6.8UCT	DF2S6.8UFS	DF3A6.8UFU		5.3	1	0.5	5.0	2 (DF2S6.8UFS) 2.5 (DF3A6.8) 1.6(Typ.) (DF2S6.8UCT)	0	±8 kV

New product

The internal connection diagrams only show the general configurations of the circuits

Extreme High-speed Type

CST6		UF6		V _Z (V)	I _Z (μ A)		C _T (pF)		ESD Immunity (IEC 61000-4-2, Contact Discharge) Min
					@I _Z (mA)	Max	@V _R (V)	@V _R (V)	
Min	Typ.	Min	Typ.						
DF6F6.8MCTC	DF6F6.8MTU	6.0	5	0.5	5.0	0.6	0	±8 kV	

New product

The internal connection diagrams only show the general configurations of the circuits

Bidirectional Type

Single			V _Z (V)		I _R (μA)		C _T (pF)		ESD Immunity (IEC 61000-4-2, Contact Discharge) Min
CST2	fSC	ESC							
			Min	Typ.	Max	@V _R (V)	Typ.	@V _R (V)	±8 kV
DF2B6.8CT	DF2B6.8FS	DF2B6.8E	5.8	6.8	0.5	5.0	15	0	

The internal connection diagrams only show the general configurations of the circuits

Integrated EMI Filter

2-in-1		4-in-1		V _Z (V)		I _Z (μA)		C _T (pF)		ESD Immunity (IEC 61000-4-2, Contact Discharge) Min
CST3	CST6F									
		Min	Typ.	Max	@V _R (V)	Max	@V _R (V)	±8 kV		
DF3S6.8ECT	DF6D6.8ECTF	5.3	6.8	0.5	5.0	40	0			

New product

The internal connection diagrams only show the general configurations of the circuits

Application Circuit Example

DVI/HDMI Connector

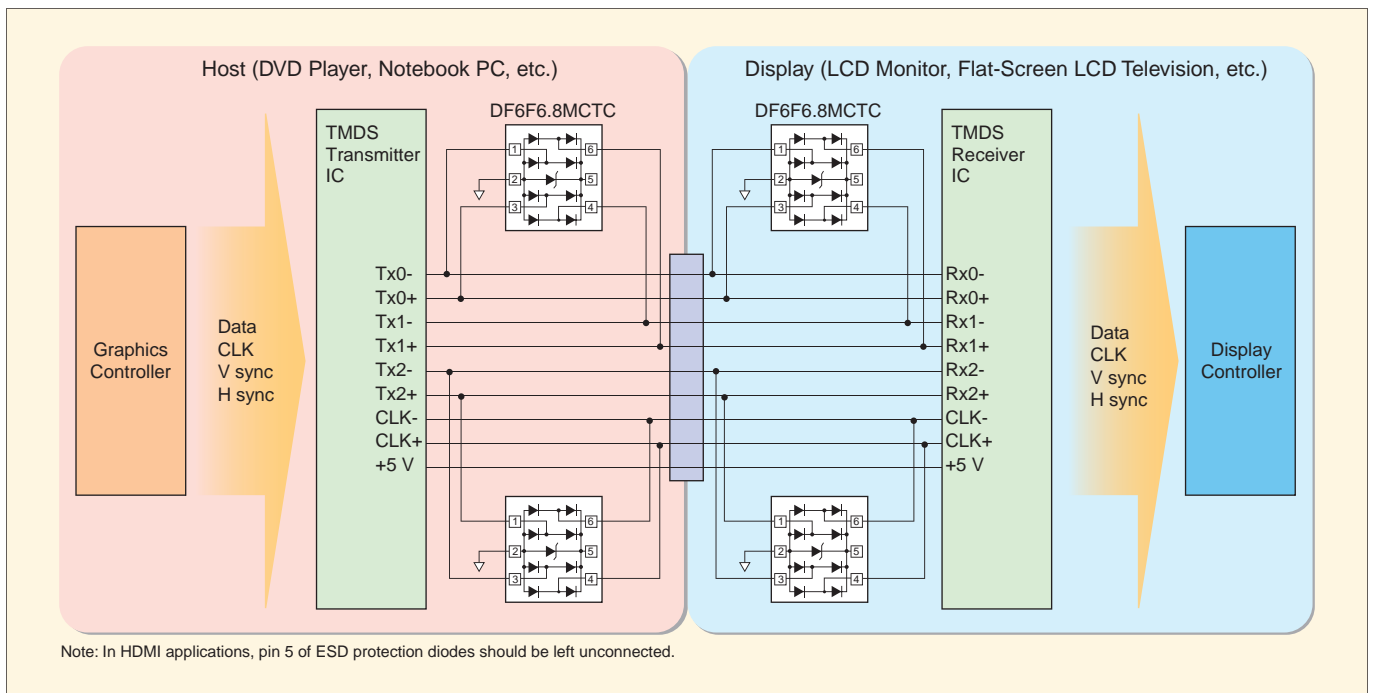

9.1 General-purpose Transistors

Classification	V _{CEO} (V)	I _c (mA)	CST3		fSM		VESM (SOT-723)		SSM (SOT-416, SC-75)		USM (SOT-323, SC-70)		UFM		TSM	S-Mini (SOT-346, SC-59)		ESV (SOT-553)	USV (SOT-353, SC-88A)	SMV (SOT-25, SC-74A)			fS6 (SOT-963)			ES6 (SOT-563)			US6 (SOT-363, SC-88)			SM6 (SOT-26, SC-74)					
			NPN	PNP	NPN	PNP	NPN	PNP	NPN	PNP	NPN	PNP	NPN	PNP	NPN	PNP	PNP + NPN	NPN	PNP	NPN	PNP	PNP + NPN	NPN	PNP	PNP + NPN	NPN	PNP	PNP + NPN	NPN	PNP	PNP + NPN	NPN	PNP	PNP + NPN			
			General-purpose	50	150	—	—	—	—	2SC6026MFV	2SA2154MFV	2SC4738	2SA1832	2SC4116	2SA1586	—	—	—	2SC2712	2SA1162	△HN4B01JE	△2SC4944	△2SA1873	△2SC4207	△2SA1618	—	—	—	—	—	—	○HN1C01FE	○HN1A01FE	—	○HN1C01FU	○HN1A01FU	○HN1B01FU
	50	100	2SC6026CT	2SA2154CT	2SC6026	2SA2154	—	—	—	—	—	—	—	—	—	—	—	—	—	△HN4A56JU	—	—	—	—	—	—	—	—	—	—	—	—	—	—	—		
Low noise	120	100	—	—	—	—	—	—	—	2SC4117	2SA1587	—	—	—	—	2SC2713	2SA1163	—	—	—	—	—	—	—	—	—	—	—	—	—	—	—	—	—	—		
General-purpose	30	500	—	—	—	—	—	—	—	2SC4118	2SA1588	—	—	—	—	2SC2859	2SA1182	—	—	—	—	—	—	—	—	—	—	—	—	—	—	—	—	—	—	○HN1B04F	
Low saturation voltage	12	400	2SC5376CT	2SA1955CT	—	—	2SC5376FV	2SA1955FV	2SC5376	2SA1955	—	—	—	—	—	—	—	—	—	△HN4C05JU	—	—	—	—	—	—	—	—	—	—	—	—	—	—	—	—	
	12	500	—	—	—	—	—	—	—	2SC5233	2SA1954	—	—	—	—	2SC5232	2SA1953	—	—	—	—	—	—	—	—	—	—	—	—	—	—	—	—	—	—		
	15	800	—	—	—	—	—	—	—	—	—	—	—	—	—	2SA1362	—	—	—	—	—	—	—	—	—	—	—	—	—	—	—	—	—	—	○HN1A02F		
High current	20	1500	—	—	—	—	—	—	—	—	—	—	2SC6133	2SA2214	—	—	—	—	—	—	—	—	—	—	—	—	—	—	—	—	—	—	—	—	—		
	20	2500	—	—	—	—	—	—	—	—	—	—	—	—	—	—	—	—	—	—	—	—	—	—	—	—	—	—	—	—	—	—	—	—	—		
	25	800	—	—	—	—	—	—	—	—	—	—	—	—	—	2SC3265	2SA1298	—	—	—	—	—	—	—	—	—	—	—	—	—	—	—	—	—	—	—	
	30	800	—	—	—	—	—	—	—	—	—	—	—	—	—	—	2SA1621	—	—	—	—	—	—	—	—	—	—	—	—	—	—	—	—	—	—	—	
	30	3000	—	—	—	—	—	—	—	—	—	—	2SC6134	—	—	—	—	—	—	—	—	—	—	—	—	—	—	—	—	—	—	—	—	—	—		
	50	1000	—	—	—	—	—	—	—	—	—	—	2SC6135	—	—	—	—	—	—	—	—	—	—	—	—	—	—	—	—	—	—	—	—	—	—		
	50	1700	—	—	—	—	—	—	—	—	—	—	—	—	—	2SA2195	—	—	—	—	—	—	—	—	—	—	—	—	—	—	—	—	—	—	—		
	50	2500	—	—	—	—	—	—	—	—	—	—	2SC6100	—	—	—	—	—	—	—	—	—	—	—	—	—	—	—	—	—	—	—	—	—	—		
High breakdown voltage	50	150	—	—	—	—	—	—	—	—	—	—	—	—	—	2SA1620	—	—	—	—	—	—	—	—	—	—	—	—	—	—	—	—	—	—	—	—	
Muting	20	300	—	—	—	—	—	—	—	2SC4213	—	—	—	—	—	2SC3326	—	—	—	—	—	—	—	—	—	—	—	—	—	—	—	—	—	—	○HN1C03FU	○HN1C03F	
High-voltage switching	200	50	—	—	—	—	—	—	—	—	—	—	—	—	—	2SC3138	—	—	—	—	—	—	—	—	—	—	—	—	—	—	—	—	—	—	—	—	
High breakdown voltage	300	100	—	—	—	—	—	—	—	—	—	—	—	—	—	2SC4497	2SA1721	—	—	—	—	—	—	—	—	—	—	—	—	—	—	—	—	—	—	—	
Strobe	10	3000	—	—	—	—	—	—	—	—	—	—	—	2SC5766	—	—	—	—	—	—	—	—	—	—	—	—	—	—	—	—	—	—	—	—	—		

- : New product
- : Point-symmetrical connections
- : Parallel connections
- × : Cascaded connections
- △ : Common emitter
- ▲ : Common base

9.2 Bias Resistor Built-in Transistors (BRTs)

Ratings		General-Purpose Type							
		V _{CEO} (V)		50		100			
		I _c (mA)		100					
Package		VESM (SOT-723)		SSM (SOT-416, SC-75)		USM (SOT-323, SC-70)		S-Mini (SOT-346, SC-59)	
Polarity		NPN	PNP	NPN	PNP	NPN	PNP	NPN	PNP
*Internal Connections									
R1	R2								
4.7	4.7	RN1101MFV	RN2101MFV	RN1101	RN2101	RN1301	RN2301	RN1401	RN2401
10	10	RN1102MFV	RN2102MFV	RN1102	RN2102	RN1302	RN2302	RN1402	RN2402
22	22	RN1103MFV	RN2103MFV	RN1103	RN2103	RN1303	RN2303	RN1403	RN2403
47	47	RN1104MFV	RN2104MFV	RN1104	RN2104	RN1304	RN2304	RN1404	RN2404
2.2	47	RN1105MFV	RN2105MFV	RN1105	RN2105	RN1305	RN2305	RN1405	RN2405
4.7	47	RN1106MFV	RN2106MFV	RN1106	RN2106	RN1306	RN2306	RN1406	RN2406
10	47	RN1107MFV	RN2107MFV	RN1107	RN2107	RN1307	RN2307	RN1407	RN2407
22	47	RN1108MFV	RN2108MFV	RN1108	RN2108	RN1308	RN2308	RN1408	RN2408
47	22	RN1109MFV	RN2109MFV	RN1109	RN2109	RN1309	RN2309	RN1409	RN2409
4.7	∞	RN1110MFV	RN2110MFV	RN1110	RN2110	RN1310	RN2310	RN1410	RN2410
10	∞	RN1111MFV	RN2111MFV	RN1111	RN2111	RN1311	RN2311	RN1411	RN2411
22	∞	RN1112MFV	RN2112MFV	RN1112	RN2112	RN1312	RN2312	RN1412	RN2412
47	∞	RN1113MFV	RN2113MFV	RN1113	RN2113	RN1313	RN2313	RN1413	RN2413
1	10	RN1114MFV	RN2114MFV	RN1114	RN2114	RN1314	RN2314	RN1414	RN2414
2.2	10	RN1115MFV	RN2115MFV	RN1115	RN2115	RN1315	RN2315	RN1415	RN2415
4.7	10	RN1116MFV	RN2116MFV	RN1116	RN2116	RN1316	RN2316	RN1416	RN2416
10	4.7	RN1117MFV	RN2117MFV	RN1117	RN2117	RN1317	RN2317	RN1417	RN2417
47	10	RN1118MFV	RN2118MFV	RN1118	RN2118	RN1318	RN2318	RN1418	RN2418
1	∞	RN1119MFV	RN2119MFV						
100	100	RN1130MFV	RN2130MFV						
100	∞	RN1131MFV	RN2131MFV						
200	∞	RN1132MFV	RN2132MFV						

*The internal connection diagrams only show the general configurations of the circuits.

Ratings		General-Purpose Type											
		V _{CEO} (V)		50		100							
		I _c (mA)		100									
Package		ESV (SOT-553)		USV (SOT-353, SC-88A)		SMV (SOT-25, SC-74A)		ES6 (SOT-563)					
Polarity		NPN	PNP	NPN	PNP	NPN	PNP	NPN x 2	PNP x 2	PNP + NPN	NPN + PNP	NPN x 2	PNP x 2
*Internal Connections													
R1	R2												
4.7	4.7	RN1701JE	RN2701JE	RN1701	RN2701	RN1501	RN2501	RN1901FE	RN2901FE	RN4901FE	RN4981FE	RN1961FE	RN2961FE
10	10	RN1702JE	RN2702JE	RN1702	RN2702	RN1502	RN2502	RN1902FE	RN2902FE	RN4902FE	RN4982FE	RN1962FE	RN2962FE
22	22	RN1703JE	RN2703JE	RN1703	RN2703	RN1503	RN2503	RN1903FE	RN2903FE	RN4903FE	RN4983FE	RN1963FE	RN2963FE
47	47	RN1704JE	RN2704JE	RN1704	RN2704	RN1504	RN2504	RN1904FE	RN2904FE	RN4904FE	RN4984FE	RN1964FE	RN2964FE
2.2	47	RN1705JE	RN2705JE	RN1705	RN2705	RN1505	RN2505	RN1905FE	RN2905FE	RN4905FE	RN4985FE	RN1965FE	RN2965FE
4.7	47	RN1706JE	RN2706JE	RN1706	RN2706	RN1506	RN2506	RN1906FE	RN2906FE	RN4906FE	RN4986FE	RN1966FE	RN2966FE
10	47	RN1707JE	RN2707JE	RN1707	RN2707	RN1507	RN2507	RN1907FE	RN2907FE	RN4907FE	RN4987FE	RN1967FE	RN2967FE
22	47	RN1708JE	RN2708JE	RN1708	RN2708	RN1508	RN2508	RN1908FE	RN2908FE	RN4908FE	RN4988FE	RN1968FE	RN2968FE
47	22	RN1709JE	RN2709JE	RN1709	RN2709	RN1509	RN2509	RN1909FE	RN2909FE	RN4909FE	RN4989FE	RN1969FE	RN2969FE
4.7	∞	RN1710JE	RN2710JE	RN1710	RN2710	RN1510	RN2510	RN1910FE	RN2910FE	RN4910FE	RN4990FE	RN1970FE	RN2970FE
10	∞	RN1711JE	RN2711JE	RN1711	RN2711	RN1511	RN2511	RN1911FE	RN2911FE	RN4911FE	RN4991FE	RN1971FE	RN2971FE
22	∞		RN2712JE										
47	∞		RN2713JE										
1	10				RN2714								

*The internal connection diagrams only show the general configurations of the circuits.

		General-Purpose Type									
Ratings	V _{CEO} (V)	50									
	I _c (mA)	100									
Package		US6 (SOT-363, SC-88)					SM6 (SOT-26, SC-74)				
Polarity		NPN x 2	PNP x 2	NPN x 2	PNP x 2	PNP + NPN	NPN + PNP	NPN x 2	NPN x 2	PNP x 2	PNP + NPN
*Internal Connections											
Internal Resistors (kΩ)											
R1	R2										
4.7	4.7	RN1901	RN2901	RN1961	RN2961	RN4901	RN4981		RN1601	RN2601	RN4601
10	10	RN1902	RN2902	RN1962	RN2962	RN4902	RN4982		RN1602	RN2602	RN4602
22	22	RN1903	RN2903	RN1963	RN2963	RN4903	RN4983		RN1603	RN2603	RN4603
47	47	RN1904	RN2904	RN1964	RN2964	RN4904	RN4984		RN1604	RN2604	RN4604
2.2	47	RN1905	RN2905	RN1965	RN2965	RN4905	RN4985		RN1605	RN2605	RN4605
4.7	47	RN1906	RN2906	RN1966	RN2966	RN4906	RN4986		RN1606	RN2606	RN4606
10	47	RN1907	RN2907	RN1967	RN2967	RN4907	RN4987		RN1607	RN2607	RN4607
22	47	RN1908	RN2908	RN1968	RN2968	RN4908	RN4988		RN1608	RN2608	RN4608
47	22	RN1909	RN2909	RN1969	RN2969	RN4909	RN4989		RN1609	RN2609	RN4609
4.7	∞	RN1910	RN2910	RN1970	RN2970	RN4910	RN4990		RN1610	RN2610	RN4610
10	∞	RN1911	RN2911	RN1971	RN2971	RN4911	RN4991		RN1611	RN2611	RN4611
22	∞										RN4612
47	∞			RN1973				RN1673			
1	∞										
2.2	∞				RN2975						

*The internal connection diagrams only show the general configurations of the circuits.

		General-Purpose Type					Low Saturation				
Ratings	V _{CEO} (V)	50					20				
	I _c (mA)	80					50				
Package		fS6 (SOT-963)			fSM		fS6 (SOT-963)				
Polarity		NPN	PNP	PNP + NPN	NPN	PNP	NPN x 2	PNP x 2	NPN x 2	PNP x 2	NPN + PNP
*Internal Connections											
Internal Resistors (kΩ)											
R1	R2										
4.7	4.7	RN1901AFS	RN2901AFS	RN4981AFS	RN1101FS	RN2101FS	RN1961FS	RN2961FS	RN1901FS	RN2901FS	RN4981FS
10	10	RN1902AFS	RN2902AFS	RN4982AFS	RN1102FS	RN2102FS	RN1962FS	RN2962FS	RN1902FS	RN2902FS	RN4982FS
22	22	RN1903AFS	RN2903AFS	RN4983AFS	RN1103FS	RN2103FS	RN1963FS	RN2963FS	RN1903FS	RN2903FS	RN4983FS
47	47	RN1904AFS	RN2904AFS	RN4984AFS	RN1104FS	RN2104FS	RN1964FS	RN2964FS	RN1904FS	RN2904FS	RN4984FS
2.2	47	RN1905AFS	RN2905AFS	RN4985AFS	RN1105FS	RN2105FS	RN1965FS	RN2965FS	RN1905FS	RN2905FS	RN4985FS
4.7	47	RN1906AFS	RN2906AFS	RN4986AFS	RN1106FS	RN2106FS	RN1966FS	RN2966FS	RN1906FS	RN2906FS	RN4986FS
10	47	RN1907AFS	RN2907AFS	RN4987AFS	RN1107FS	RN2107FS	RN1967FS	RN2967FS	RN1907FS	RN2907FS	RN4987FS
22	47	RN1908AFS	RN2908AFS	RN4988AFS	RN1108FS	RN2108FS	RN1968FS	RN2968FS	RN1908FS	RN2908FS	RN4988FS
47	22	RN1909AFS	RN2909AFS	RN4989AFS	RN1109FS	RN2109FS	RN1969FS	RN2969FS	RN1909FS	RN2909FS	RN4989FS
4.7	∞	RN1910AFS	RN2910AFS	RN4990AFS	RN1110FS	RN2110FS	RN1970FS	RN2970FS	RN1910FS	RN2910FS	RN4990FS
10	∞	RN1911AFS	RN2911AFS	RN4991AFS	RN1111FS	RN2111FS	RN1971FS	RN2971FS	RN1911FS	RN2911FS	RN4991FS
22	∞	RN1912AFS	RN2912AFS	RN4992AFS	RN1112FS	RN2112FS	RN1972FS	RN2972FS	RN1912FS	RN2912FS	RN4992FS
47	∞	RN1913AFS	RN2913AFS	RN4993AFS	RN1113FS	RN2113FS	RN1973FS	RN2973FS	RN1913FS	RN2913FS	RN4993FS

*The internal connection diagrams only show the general configurations of the circuits.

Small-Signal Transistors in Ultra-Small CST Packages

Ratings	V _{CEO} (V)		Low Saturation				General-Purpose Type			
	I _c (mA)		20	-20	20	-20	50	-50	50	-50
Package		CST3		CST6		CST3		CST6		
Polarity		NPN	PNP	NPN	PNP	NPN	PNP	NPN + PNP		
*Internal Connections										
Internal Resistors (kΩ)		R1	R2							
4.7	4.7	RN1101CT	RN2101CT	RN1961CT	RN2961CT	RN1101ACT	RN2101ACT			
10	10	RN1102CT	RN2102CT	RN1962CT	RN2962CT	RN1102ACT	RN2102ACT			
22	22	RN1103CT	RN2103CT	RN1963CT	RN2963CT	RN1103ACT	RN2103ACT			
47	47	RN1104CT	RN2104CT	RN1964CT	RN2964CT	RN1104ACT	RN2104ACT			
2.2	47	RN1105CT	RN2105CT	RN1965CT	RN2965CT	RN1105ACT	RN2105ACT			
4.7	47	RN1106CT	RN2106CT	RN1966CT	RN2966CT	RN1106ACT	RN2106ACT	RN49P2ACT		
10	47	RN1107CT	RN2107CT	RN1967CT	RN2967CT	RN1107ACT	RN2107ACT			
22	47	RN1108CT	RN2108CT	RN1968CT	RN2968CT	RN1108ACT	RN2108ACT			
47	22	RN1109CT	RN2109CT	RN1969CT	RN2969CT	RN1109ACT	RN2109ACT			
4.7	∞	RN1110CT	RN2110CT	RN1970CT	RN2970CT	RN1110ACT	RN2110ACT			
10	∞	RN1111CT	RN2111CT	RN1971CT	RN2971CT	RN1111ACT	RN2111ACT			
22	∞	RN1112CT	RN2112CT	RN1972CT	RN2972CT	RN1112ACT	RN2112ACT			
47	∞	RN1113CT	RN2113CT	RN1973CT	RN2973CT	RN1113ACT	RN2113ACT			

*The internal connection diagrams only show the general configurations of the circuits.

Dual BRTs in 5-Pin ESV and USV Packages

Ratings	V _{CEO} (V)		50/-50		Constituent Devices	*Internal Connections
	I _c (mA)		100/-100			
Package		ESV (SOT-533)	USV (SOT-353, SC-88A)			
Internal Resistors		R1 (kΩ)	R2 (kΩ)			
4.7	—	RN47A1JE	RN47A1	Q1	RN1310	
4.7	—			Q2	RN2310	
22	22	RN47A2JE	RN47A2	Q1	RN1303	
22	22			Q2	RN2303	
10	10	RN47A3JE	RN47A3	Q1	RN1302	
10	10			Q2	RN2302	
47	47	RN47A4JE	RN47A4	Q1	RN1304	
10	47			Q2	RN2307	
47	47	RN47A5JE	RN47A5	Q1	RN1304	
4.7	10			Q2	RN2316	
10	10	RN47A7JE		Q1	RN1302	
4.7	10			Q2	-12 V/-100 mA Low V _{CE(sat)}	
10	10	RN47A8JE		Q1	RN1102	
10	47			Q2	High h _{EF} (-30 V/-100 mA)	
100	100		RN47A6	Q1	RN1130MFV	
100	100			Q2	RN2130MFV	

*The internal connection diagrams only show the general configurations of the circuits.

Bias Resistor Built-in Transistors (BRTs)

■ Dual BRTs in the 6-Pin fS6 Package

Internal Resistors		Part Number	Ratings		Constituent Devices		*Internal Connections
R1 (kΩ)	R2 (kΩ)		V _{CEO} (V)	I _c (mA)	Q1	Q2	
47	47	RN49A6FS	20	50	Q1	RN1104FS	
4.7	47		-20	-50	Q2	RN2106FS	
47	47	RN49J2FS	-20	-50	Q1	RN2104FS	
47	47		20	50	Q2	RN1104FS	
47	47	RN49J2AFS	-50	-50	Q1	RN2904AFS	
47	47		50	50	Q2	RN1904AFS	
47	47	RN49J7FS	-20	-50	Q1	RN2104FS	
47	47		20	50	Q2	RN1104FS	

*The internal connection diagrams only show the general configurations of the circuits.

■ Dual BRTs in the 6-Pin ES6, US6 and SM6 Packages

Ratings	V _{CEO} (V)	I _c (mA)	Package			Constituent Devices	*Internal Connections	
			ES6 (SOT-563)	US6 (SOT-363, SC-88)	SM6 (SOT-26, SC-74)			
Internal Resistors		-50/50		-100/100				
R1 (kΩ)	R2 (kΩ)							
2.2	47	RN49A1FE	RN49A1			Q1	RN2305	
22	47					Q2	RN1308	
22	22	RN46A1				Q1	RN2303	
10	10					Q2	RN1302	
2.2	47					Q1	RN2305	
47	47					Q2	RN1304	
0.47	10	RN49A4FE				Q1	RN2325A	
10	—					Q2	RN1111	
10	10	RN49A5				Q1	RN1107	
2.2	10					Q2	RN2327A	

*The internal connection diagrams only show the general configurations of the circuits.

Ratings	V _{CEO} (V)	I _c (mA)	High Current				Muting
			USM (SOT-323, SC-70)		S-Mini (SOT-346, SC-59)		S-Mini (SOT-346, SC-59)
Package							
Polarity		NPN	PNP	NPN	PNP	NPN	
*Internal Connections							
Internal Resistors (kΩ)							
R1	R2						
1	1	RN1321A	RN2321A	RN1421	RN2421		
2.2	2.2	RN1322A	RN2322A	RN1422	RN2422		
4.7	4.7	RN1323A	RN2323A	RN1423	RN2423		
10	10	RN1324A	RN2324A	RN1424	RN2424		
0.47	10	RN1325A	RN2325A	RN1425	RN2425		
1	10	RN1326A	RN2326A	RN1426	RN2426		
2.2	10	RN1327A	RN2327A	RN1427	RN2427		
5.6	∞					RN1441	
10	∞					RN1442	
22	∞					RN1443	
2.2	∞					RN1444	

*The internal connection diagrams only show the general configurations of the circuits.

■ BRTs for Mute Switch Applications

Ratings	V _{CEO} (V)	I _c (mA)	Package	Polarity	*Internal Connections
	20	300	SMV	NPN x 2	
Internal Resistors (kΩ)		R1	R2		
		2.2	∞	RN1544	

*The internal connection diagrams only show the general configurations of the circuits.

■ High-hFE BRTs

Ratings	V _{CEO} (V)	I _c (mA)	Package	Polarity	*Internal Connections
	40/-30	100/-100	ES6	PNP x 2	
				NPN + PNP	
Internal Resistors (kΩ)		R1	R2		
		22	∞	RN2972HFE	RN4992HFE

*The internal connection diagrams only show the general configurations of the circuits.

9.3 Multi-Chip Discrete Devices

Semi-Custom MCDs

Toshiba offers semi-custom multi-chip devices, which can be tailored to suit your unique needs. These devices help to reduce external component count, thus saving board space and cost.

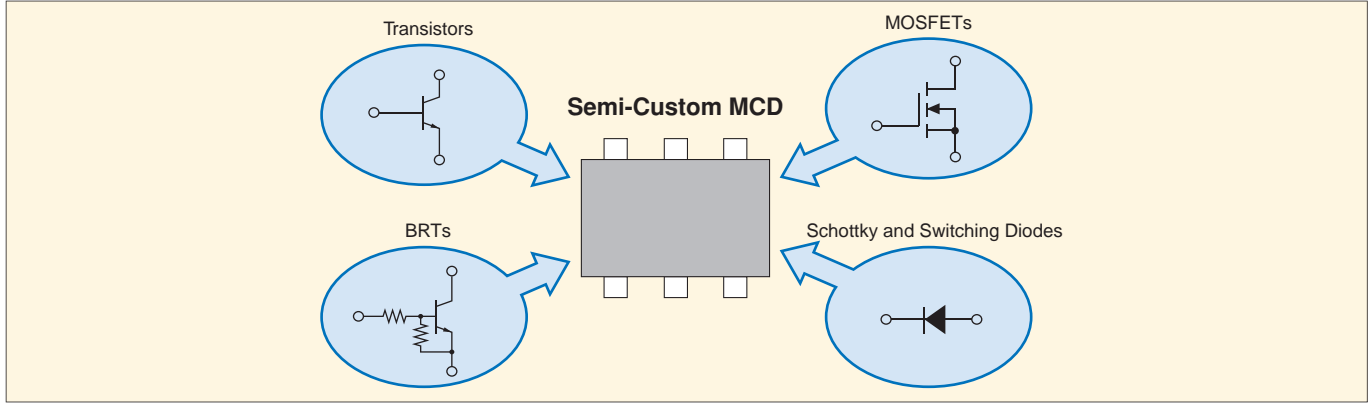

MCDs in 5-Pin ESV, USV and SMV Packages and 6-Pin ES6, US6 and SM6 Packages

*Internal Connections	Part Number						Unit: mm	Constituent Devices	Ratings		Features	
	ESV (1.6x1.6 mm) (SOT-553)	ES6 (1.6x1.6 mm) (SOT-563)	USV (2x2.1 mm) (SOT-353) (SC-88A)	US6 (2x2.1 mm) (SOT-363) (SC-88)	SMV (2.9x2.8 mm) (SOT-25) (SC-74A)	SM6 (2.9x2.8 mm) (SOT-26) (SC-74)			Voltage (V)	Current (mA)		
PNP + N-ch		-	-	-	HN7G01FU	-	-	Q1 2SA1954	V _{CEO}	-12	I _c -400	Low-saturation PNP transistor Suitable for current switches
		-	-	-	HN7G03FU	-	-	Q2 2SK1829	V _{DS}	20	I _b 50	2.5-V gate drive (V _{th} = 1.5 V max) Ron = 20 Ω (typ.)
PNP(BRT) + N-ch		-	-	-	HN7G02FU	-	-	Q1 2SA1954	V _{CEO}	-12	I _c -400	Low-saturation PNP transistor Suitable for current switches
		-	-	-	-	-	-	Q2 SSM3K04FU	V _{DS}	20	I _b 100	Built-in 1-MΩ gate-source resistor; 2.5-V gate drive (V _{th} = 1.3 V max); Ron = 4 Ω (typ.)
PNP + NPN(BRT)		-	-	-	HN7G04FU	-	-	Q1 2SA1954	V _{CEO}	-12	I _c -400	Low-saturation PNP transistor Suitable for current switches
		-	-	-	-	-	-	Q2 RN1307	V _{CEO}	50	I _c 100	BRT (NPN) R1 = 10 kΩ, R2 = 47 kΩ
PNP(BRT) + N-ch		-	-	-	HN7G05FU	-	-	Q1 RN2101	V _{CEO}	-50	I _c -100	BRT (PNP) R1 = 4.7 kΩ, R2 = 4.7 kΩ
		-	-	-	-	-	-	Q2 2SK1830	V _{DS}	20	I _b 50	2.5-V gate drive (V _{th} = 1.5 V max) Ron = 20 Ω (typ.)
PNP + NPN(BRT)		-	HN7G06FE	-	HN7G06FU	-	-	Q1 2SA1955F	V _{CEO}	-12	I _c -400	Low-saturation PNP transistor Suitable for current switches
		-	-	-	-	-	-	Q2 RN1104F	V _{CEO}	50	I _c 100	BRT (NPN) R1 = 47 kΩ, R2 = 47 kΩ
NPN + NPN(BRT)		-	-	-	HN7G07FU	-	-	Q1 2SC5376F	V _{CEO}	12	I _c 400	Low-saturation NPN transistor
		-	-	-	-	-	-	Q2 RN1115F	V _{CEO}	50	I _c 100	BRT (NPN) R1 = 2.2 kΩ, R2 = 10 kΩ
PNP + NPN(BRT)		-	HN7G08FE	-	-	-	-	Q1 2SA1954	V _{CEO}	-12	I _c -500	Low-saturation PNP transistor Suitable for current switches
		-	-	-	-	-	-	Q2 RN1306	V _{CEO}	50	I _c 100	BRT (NPN) R1 = 4.7 kΩ, R2 = 47 kΩ
NPN(BRT) + N-ch		-	HN7G09FE	-	-	-	-	Q1 RN1104F	V _{CEO}	50	I _c 100	BRT (NPN) R1 = 47 kΩ, R2 = 47 kΩ
		-	-	-	-	-	-	Q2 SSM3K15FS	V _{DS}	30	I _b 100	2.5-V gate drive (V _{th} = 1.5 V max) Ron = 4 Ω (typ.)
NPN + NPN (BRT)		-	-	-	-	-	HN7G11F	Q1 2SA2214	V _{CEO}	-20	I _c 1500	High-current PNP transistor
		-	-	-	-	-	-	Q2 RN1102	V _{CEO}	50	I _c 100	BRT (NPN) R1 = 10 kΩ, R2 = 10 kΩ
NPN + NPN (BRT)		-	-	-	-	HN4G01J	-	Q1 2SC2712	V _{CEO}	50	I _c 150	General-purpose NPN transistor
		-	-	-	-	-	-	Q2 RN1103F	V _{CEO}	50	I _c 100	BRT (NPN) R1 = 22 kΩ, R2 = 22 kΩ
Small-signal diode + NPN		-	-	-	-	-	-	Q1 1SS352	V _R	80	I _o 100	General-purpose; high-speed switching
		-	-	-	-	-	-	Q2 2SC4666	V _{CEO}	50	I _c 150	High-hFE NPN transistor
PNP + Small-signal diode		-	-	-	-	-	HN2E02F	Q1 1SS352	V _R	80	I _o 100	General-purpose; high-speed switching
		-	-	-	-	-	-	Q2 2SC4116	V _{CEO}	50	I _c 150	General-purpose NPN transistor
BRT(PNP) + Small-signal diode		-	-	-	-	-	HN2E04F	Q1 2SA1587	V _{CEO}	-120	I _c -100	High-V _{CEO} PNP transistor
		-	-	-	-	-	-	Q2 1SS352	V _R	80	I _o 100	General-purpose; high-speed switching
Small-signal SBD + PNP (BRT)		HN2E07JE	-	-	-	-	-	Q1 ISS417	V _R	40	I _o 100	Schottky barrier diode (standard type)
		-	-	-	-	-	-	Q2 RN2104MFV	V _{CEO}	-50	I _c 100	BRT (PNP) R1 = 47 kΩ, R2 = 47 kΩ

New product

*The internal connection diagrams only show the general configurations of the circuits.

■ Small-Signal Diodes

■ Switching Diode and Schottky Barrier Diodes

Part Number	Package		
	Toshiba	JEITA	–
1SS413	fSC	–	–
1SS416	fSC	–	–
1SS417	fSC	–	–
1SS387	ESC	SC-79	SOD-523
1SS388	ESC	SC-79	SOD-523
1SS389	ESC	SC-79	SOD-523
1SS405	ESC	SC-79	SOD-523
1SS420	ESC	SC-79	SOD-523
1SS421	ESC	SC-79	SOD-523
1SS424	ESC	SC-79	SOD-523
DSF521	ESC	SC-79	SOD-523
DSR520	ESC	SC-79	SOD-523
1SS352	USC	SC-76	SOD-323
1SS357	USC	SC-76	SOD-323
1SS367	USC	SC-76	SOD-323
1SS403	USC	SC-76	SOD-323
1SS404	USC	SC-76	SOD-323
1SS406	USC	SC-76	SOD-323
1SS361FV	VESM	SOT-105AA	SOT-723
1SS385FV	VESM	SOT-105AA	SOT-723
1SS360	SSM	SC-75	SOT-416
1SS361	SSM	SC-75	SOT-416
1SS362	SSM	SC-75	SOT-416
1SS385	SSM	SC-75	SOT-416
1SS422	SSM	SC-75	SOT-416
1SS423	SSM	SC-75	SOT-416
1SS300	USM	SC-70	SOT-323
1SS301	USM	SC-70	SOT-323
1SS302	USM	SC-70	SOT-323
1SS322	USM	SC-70	SOT-323
1SS370	USM	SC-70	SOT-323
1SS372	USM	SC-70	SOT-323
1SS378	USM	SC-70	SOT-323
1SS393	USM	SC-70	SOT-323
1SS395	USM	SC-70	SOT-323
1SS397	USM	SC-70	SOT-323
1SS401	USM	SC-70	SOT-323
1SS412	USM	SC-70	SOT-323
1SS181	S-Mini	SC-59	SOT-346
1SS184	S-Mini	SC-59	SOT-346
1SS187	S-Mini	SC-59	SOT-346
1SS190	S-Mini	SC-59	SOT-346
1SS193	S-Mini	SC-59	SOT-346
1SS196	S-Mini	SC-59	SOT-346
1SS226	S-Mini	SC-59	SOT-346
1SS250	S-Mini	SC-59	SOT-346
1SS294	S-Mini	SC-59	SOT-346
1SS307	S-Mini	SC-59	SOT-346
1SS311	S-Mini	SC-59	SOT-346
1SS321	S-Mini	SC-59	SOT-346
1SS374	S-Mini	SC-59	SOT-346
1SS377	S-Mini	SC-59	SOT-346
1SS379	S-Mini	SC-59	SOT-346
1SS392	S-Mini	SC-59	SOT-346
1SS394	S-Mini	SC-59	SOT-346

Part Number	Package		
	Toshiba	JEITA	–
1SS396	S-Mini	SC-59	SOT-346
1SS398	S-Mini	SC-59	SOT-346
HN4D01JU	USV	SC-88A	SOT-353
HN4D02JU	USV	SC-88A	SOT-353
HN1D01FU	US6	SC-88	SOT-363
HN1D02FU	US6	SC-88	SOT-363
HN1D03FU	US6	SC-88	SOT-363
HN1D04FU	US6	SC-88	SOT-363
HN2D01FU	US6	SC-88	SOT-363
HN2S01FU	US6	SC-88	SOT-363
HN2S02FU	US6	SC-88	SOT-363
HN2S03FU	US6	SC-88	SOT-363
HN2S04FU	US6	SC-88	SOT-363
HN2S05FU	US6	SC-88	SOT-363
HN1D01FE	ES6	SC-107C	SOT-563
HN1D02FE	ES6	SC-107C	SOT-563

■ ESD-Protection Diodes

Part Number	Package		
	Toshiba	JEITA	–
DF2S10FS	fSC	–	–
DF2S12FS	fSC	–	–
DF2S16FS	fSC	–	–
DF2S20FS	fSC	–	–
DF2S24FS	fSC	–	–
DF2S30FS	fSC	–	–
DF2S5.6FS	fSC	–	–
DF2S6.2FS	fSC	–	–
DF2S6.8FS	fSC	–	–
DF2S6.8UFS	fSC	–	–
DF2S8.2FS	fSC	–	–
DF2B6.8FS	fSC	–	–
DF2S12FU	USC	SC-76	SOD-323
DF2S6.8FU	USC	SC-76	SOD-323
DF3A3.3FV	VESM	SOT-105AA	SOT-723
DF3A5.6FV	VESM	SOT-105AA	SOT-723
DF3A6.2LFV	VESM	SOT-105AA	SOT-723
DF3A6.8FV	VESM	SOT-105AA	SOT-723
DF3A6.8LFV	VESM	SOT-105AA	SOT-723
DF3A3.3FU	USM	SC-70	SOT-323
DF3A3.6FU	USM	SC-70	SOT-323
DF3A4.3FU	USM	SC-70	SOT-323
DF3A5.6FU	USM	SC-70	SOT-323
DF3A5.6LFU	USM	SC-70	SOT-323
DF3A6.2FU	USM	SC-70	SOT-323
DF3A6.2LFU	USM	SC-70	SOT-323
DF3A6.8FU	USM	SC-70	SOT-323
DF3A6.8LFU	USM	SC-70	SOT-323
DF3A6.8UFU	USM	SC-70	SOT-323
DF3A8.2FU	USM	SC-70	SOT-323
DF3A8.2LFU	USM	SC-70	SOT-323
DF3A5.6F	S-Mini	SC-59	SOT-346
DF3A6.2F	S-Mini	SC-59	SOT-346
DF3A6.8F	S-Mini	SC-59	SOT-346

■ ESD-Protection Diodes (Continued)

Part Number	Package		
	Toshiba	JEITA	—
DF5A12FU	USV	SC-88A	SOT-353
DF5A3.3FU	USV	SC-88A	SOT-353
DF5A3.6CFU	USV	SC-88A	SOT-353
DF5A3.6FU	USV	SC-88A	SOT-353
DF5A5.6CFU	USV	SC-88A	SOT-353
DF5A5.6FU	USV	SC-88A	SOT-353
DF5A5.6LFU	USV	SC-88A	SOT-353
DF5A6.2CFU	USV	SC-88A	SOT-353
DF5A6.2FU	USV	SC-88A	SOT-353
DF5A6.2LFU	USV	SC-88A	SOT-353
DF5A6.8CFU	USV	SC-88A	SOT-353
DF5A6.8FU	USV	SC-88A	SOT-353
DF5A6.8LFU	USV	SC-88A	SOT-353
DF5A8.2CFU	USV	SC-88A	SOT-353
DF5A8.2FU	USV	SC-88A	SOT-353
DF5A8.2LFU	USV	SC-88A	SOT-353
DF6A6.8FU	US6	SC-88	SOT-363
DF7A6.8CFU	US6	SC-88	SOT-363

■ Junction FETs

Part Number	Package		
	Toshiba	JEITA	—
TTK101TK	TESM3	—	—
2SK4059TK	TESM3	—	—
TTK101MFV	VESM	SC-105AA	SOT-723
2SK4059MFV	VESM	SC-105AA	SOT-723

■ Transistors

Part Number	Package		
	Toshiba	JEITA	—
2SA1162	S-Mini	SC-59	SOT-346
2SA1163	S-Mini	SC-59	SOT-346
2SA1182	S-Mini	SC-59	SOT-346
2SA1255	S-Mini	SC-59	SOT-346
2SA1298	S-Mini	SC-59	SOT-346
2SA1312	S-Mini	SC-59	SOT-346
2SA1313	S-Mini	SC-59	SOT-346
2SA1362	S-Mini	SC-59	SOT-346
2SA1953	S-Mini	SC-59	SOT-346
2SC2532	S-Mini	SC-59	SOT-346
2SC2712	S-Mini	SC-59	SOT-346
2SC2713	S-Mini	SC-59	SOT-346
2SC2714	S-Mini	SC-59	SOT-346
2SC2715	S-Mini	SC-59	SOT-346
2SC2716	S-Mini	SC-59	SOT-346
2SC2859	S-Mini	SC-59	SOT-346
2SC3123	S-Mini	SC-59	SOT-346
2SC3138	S-Mini	SC-59	SOT-346
2SC3265	S-Mini	SC-59	SOT-346
2SC3295	S-Mini	SC-59	SOT-346
2SC3324	S-Mini	SC-59	SOT-346
2SC3325	S-Mini	SC-59	SOT-346
2SC3326	S-Mini	SC-59	SOT-346
2SC3437	S-Mini	SC-59	SOT-346
2SC5232	S-Mini	SC-59	SOT-346
TBC846	S-Mini	SC-59	SOT-346

Part Number	Package		
	Toshiba	JEITA	—
TBC847	S-Mini	SC-59	SOT-346
TBC848	S-Mini	SC-59	SOT-346
TBC849	S-Mini	SC-59	SOT-346
TBC856	S-Mini	SC-59	SOT-346
TBC857	S-Mini	SC-59	SOT-346
TBC858	S-Mini	SC-59	SOT-346
TBC859	S-Mini	SC-59	SOT-346
2SA1832	SSM	SC-75	SOT-416
2SA1955	SSM	SC-75	SOT-416
2SC4738	SSM	SC-75	SOT-416
2SC5376	SSM	SC-75	SOT-416
2SC5766	TSM	—	—
2SA2195	UFM	—	—
2SA2214	UFM	—	—
2SA2215	UFM	—	—
2SC6100	UFM	—	—
2SC6133	UFM	—	—
2SC6134	UFM	—	—
2SC6135	UFM	—	—
2SA1586	USM	SC-70	SOT-323
2SA1587	USM	SC-70	SOT-323
2SA1588	USM	SC-70	SOT-323
2SA1954	USM	SC-70	SOT-323
2SC4116	USM	SC-70	SOT-323
2SC4117	USM	SC-70	SOT-323
2SC4118	USM	SC-70	SOT-323
2SC4213	USM	SC-70	SOT-323
2SC4666	USM	SC-70	SOT-323
2SC4667	USM	SC-70	SOT-323
2SC5233	USM	SC-70	SOT-323
TTA1586FU	USM	SC-70	SOT-323
TTC4116FU	USM	SC-70	SOT-323
2SA1873	USV	SC-88A	SOT-353
2SC4944	USV	SC-88A	SOT-353
HN4A56JU	USV	SC-88A	SOT-353
HN4C05JU	USV	SC-88A	SOT-353
2SA1955FV	VESM	SC-105AA	SOT-723
2SA2154MFV	VESM	SC-105AA	SOT-723
2SC5376FV	VESM	SC-105AA	SOT-723
2SC6026MFV	VESM	SC-105AA	SOT-723
HN1A01FE	ES6	SC-107C	SOT-563
HN1B04FE	ES6	SC-107C	SOT-563
HN1C01FE	ES6	SC-107C	SOT-563
HN1C05FE	ES6	SC-107C	SOT-563
HN2A01FE	ES6	SC-107C	SOT-563
HN2C01FE	ES6	SC-107C	SOT-563
HN3C67FE	ES6	SC-107C	SOT-563
HN1A01FU	US6	SC-88	SOT-363
HN1B01FU	US6	SC-88	SOT-363
HN1B04FU	US6	SC-88	SOT-363
HN1C01FU	US6	SC-88	SOT-363
HN1C03FU	US6	SC-88	SOT-363
HN2A01FU	US6	SC-88	SOT-363
HN2C01FU	US6	SC-88	SOT-363
HN3C56FU	US6	SC-88	SOT-363
HN3C61FU	US6	SC-88	SOT-363

■ Bias Resistor Built-in Transistors

Part Number	Package		
	Toshiba	JEITA	–
RN1901FE	ES6	SC-107C	SOT-563
RN1902FE	ES6	SC-107C	SOT-563
RN1903FE	ES6	SC-107C	SOT-563
RN1904FE	ES6	SC-107C	SOT-563
RN1905FE	ES6	SC-107C	SOT-563
RN1906FE	ES6	SC-107C	SOT-563
RN1907FE	ES6	SC-107C	SOT-563
RN1908FE	ES6	SC-107C	SOT-563
RN1909FE	ES6	SC-107C	SOT-563
RN1910FE	ES6	SC-107C	SOT-563
RN1911FE	ES6	SC-107C	SOT-563
RN1912FE	ES6	SC-107C	SOT-563
RN1913FE	ES6	SC-107C	SOT-563
RN2901FE	ES6	SC-107C	SOT-563
RN2902FE	ES6	SC-107C	SOT-563
RN2903FE	ES6	SC-107C	SOT-563
RN2904FE	ES6	SC-107C	SOT-563
RN2905FE	ES6	SC-107C	SOT-563
RN2906FE	ES6	SC-107C	SOT-563
RN2907FE	ES6	SC-107C	SOT-563
RN2908FE	ES6	SC-107C	SOT-563
RN2909FE	ES6	SC-107C	SOT-563
RN2910FE	ES6	SC-107C	SOT-563
RN2911FE	ES6	SC-107C	SOT-563
RN2912FE	ES6	SC-107C	SOT-563
RN2913FE	ES6	SC-107C	SOT-563
RN4901FE	ES6	SC-107C	SOT-563
RN4902FE	ES6	SC-107C	SOT-563
RN4903FE	ES6	SC-107C	SOT-563
RN4904FE	ES6	SC-107C	SOT-563
RN4905FE	ES6	SC-107C	SOT-563
RN4906FE	ES6	SC-107C	SOT-563
RN4907FE	ES6	SC-107C	SOT-563
RN4908FE	ES6	SC-107C	SOT-563
RN4909FE	ES6	SC-107C	SOT-563
RN4910FE	ES6	SC-107C	SOT-563
RN4911FE	ES6	SC-107C	SOT-563
RN4912FE	ES6	SC-107C	SOT-563
RN4913FE	ES6	SC-107C	SOT-563
RN4981FE	ES6	SC-107C	SOT-563
RN4982FE	ES6	SC-107C	SOT-563
RN4983FE	ES6	SC-107C	SOT-563
RN4984FE	ES6	SC-107C	SOT-563
RN4985FE	ES6	SC-107C	SOT-563
RN4986FE	ES6	SC-107C	SOT-563
RN4987FE	ES6	SC-107C	SOT-563
RN4988FE	ES6	SC-107C	SOT-563
RN4989FE	ES6	SC-107C	SOT-563
RN4990FE	ES6	SC-107C	SOT-563
RN4991FE	ES6	SC-107C	SOT-563
RN4992FE	ES6	SC-107C	SOT-563
RN4993FE	ES6	SC-107C	SOT-563
RN1401	S-Mini	SC-59	SOT-346
RN1402	S-Mini	SC-59	SOT-346
RN1403	S-Mini	SC-59	SOT-346

Part Number	Package		
	Toshiba	JEITA	–
RN1404	S-Mini	SC-59	SOT-346
RN1405	S-Mini	SC-59	SOT-346
RN1406	S-Mini	SC-59	SOT-346
RN1407	S-Mini	SC-59	SOT-346
RN1408	S-Mini	SC-59	SOT-346
RN1409	S-Mini	SC-59	SOT-346
RN1410	S-Mini	SC-59	SOT-346
RN1411	S-Mini	SC-59	SOT-346
RN1412	S-Mini	SC-59	SOT-346
RN1413	S-Mini	SC-59	SOT-346
RN1414	S-Mini	SC-59	SOT-346
RN1415	S-Mini	SC-59	SOT-346
RN1416	S-Mini	SC-59	SOT-346
RN1417	S-Mini	SC-59	SOT-346
RN1418	S-Mini	SC-59	SOT-346
RN1441	S-Mini	SC-59	SOT-346
RN1442	S-Mini	SC-59	SOT-346
RN1443	S-Mini	SC-59	SOT-346
RN1444	S-Mini	SC-59	SOT-346
RN2401	S-Mini	SC-59	SOT-346
RN2402	S-Mini	SC-59	SOT-346
RN2403	S-Mini	SC-59	SOT-346
RN2404	S-Mini	SC-59	SOT-346
RN2405	S-Mini	SC-59	SOT-346
RN2406	S-Mini	SC-59	SOT-346
RN2407	S-Mini	SC-59	SOT-346
RN2408	S-Mini	SC-59	SOT-346
RN2409	S-Mini	SC-59	SOT-346
RN2410	S-Mini	SC-59	SOT-346
RN2411	S-Mini	SC-59	SOT-346
RN2412	S-Mini	SC-59	SOT-346
RN2413	S-Mini	SC-59	SOT-346
RN2414	S-Mini	SC-59	SOT-346
RN2415	S-Mini	SC-59	SOT-346
RN2416	S-Mini	SC-59	SOT-346
RN2417	S-Mini	SC-59	SOT-346
RN2418	S-Mini	SC-59	SOT-346
RN1101	SSM	SC-75	SOT-416
RN1102	SSM	SC-75	SOT-416
RN1103	SSM	SC-75	SOT-416
RN1104	SSM	SC-75	SOT-416
RN1105	SSM	SC-75	SOT-416
RN1106	SSM	SC-75	SOT-416
RN1107	SSM	SC-75	SOT-416
RN1108	SSM	SC-75	SOT-416
RN1109	SSM	SC-75	SOT-416
RN1110	SSM	SC-75	SOT-416
RN1111	SSM	SC-75	SOT-416
RN1112	SSM	SC-75	SOT-416
RN1113	SSM	SC-75	SOT-416
RN1114	SSM	SC-75	SOT-416
RN1115	SSM	SC-75	SOT-416
RN1117	SSM	SC-75	SOT-416
RN1118	SSM	SC-75	SOT-416
RN2101	SSM	SC-75	SOT-416

■ Bias Resistor Built-in Transistors (Continued)

Part Number	Package		
	Toshiba	JEITA	–
RN2102	SSM	SC-75	SOT-416
RN2103	SSM	SC-75	SOT-416
RN2104	SSM	SC-75	SOT-416
RN2105	SSM	SC-75	SOT-416
RN2106	SSM	SC-75	SOT-416
RN2107	SSM	SC-75	SOT-416
RN2108	SSM	SC-75	SOT-416
RN2109	SSM	SC-75	SOT-416
RN2110	SSM	SC-75	SOT-416
RN2111	SSM	SC-75	SOT-416
RN2112	SSM	SC-75	SOT-416
RN2113	SSM	SC-75	SOT-416
RN2114	SSM	SC-75	SOT-416
RN2115	SSM	SC-75	SOT-416
RN2116	SSM	SC-75	SOT-416
RN2117	SSM	SC-75	SOT-416
RN2118	SSM	SC-75	SOT-416
RN1901	US6	SC-88	SOT-363
RN1902	US6	SC-88	SOT-363
RN1903	US6	SC-88	SOT-363
RN1904	US6	SC-88	SOT-363
RN1905	US6	SC-88	SOT-363
RN1906	US6	SC-88	SOT-363
RN1907	US6	SC-88	SOT-363
RN1908	US6	SC-88	SOT-363
RN1909	US6	SC-88	SOT-363
RN1910	US6	SC-88	SOT-363
RN1911	US6	SC-88	SOT-363
RN2901	US6	SC-88	SOT-363
RN2902	US6	SC-88	SOT-363
RN2903	US6	SC-88	SOT-363
RN2904	US6	SC-88	SOT-363
RN2905	US6	SC-88	SOT-363
RN2906	US6	SC-88	SOT-363
RN2907	US6	SC-88	SOT-363
RN2908	US6	SC-88	SOT-363
RN2909	US6	SC-88	SOT-363
RN2910	US6	SC-88	SOT-363
RN2911	US6	SC-88	SOT-363
RN4901	US6	SC-88	SOT-363
RN4902	US6	SC-88	SOT-363
RN4903	US6	SC-88	SOT-363
RN4904	US6	SC-88	SOT-363
RN4905	US6	SC-88	SOT-363
RN4906	US6	SC-88	SOT-363
RN4907	US6	SC-88	SOT-363
RN4908	US6	SC-88	SOT-363
RN4909	US6	SC-88	SOT-363
RN4910	US6	SC-88	SOT-363
RN4911	US6	SC-88	SOT-363
RN4981	US6	SC-88	SOT-363
RN4982	US6	SC-88	SOT-363
RN4983	US6	SC-88	SOT-363
RN4984	US6	SC-88	SOT-363
RN4985	US6	SC-88	SOT-363

Part Number	Package		
	Toshiba	JEITA	–
RN4986	US6	SC-88	SOT-363
RN4987	US6	SC-88	SOT-363
RN4988	US6	SC-88	SOT-363
RN4989	US6	SC-88	SOT-363
RN4990	US6	SC-88	SOT-363
RN4991	US6	SC-88	SOT-363
RN49A1	US6	SC-88	SOT-363
RN49A2	US6	SC-88	SOT-363
RN49A5	US6	SC-88	SOT-363
RN1301	USM	SC-70	SOT-323
RN1302	USM	SC-70	SOT-323
RN1303	USM	SC-70	SOT-323
RN1304	USM	SC-70	SOT-323
RN1305	USM	SC-70	SOT-323
RN1306	USM	SC-70	SOT-323
RN1307	USM	SC-70	SOT-323
RN1308	USM	SC-70	SOT-323
RN1309	USM	SC-70	SOT-323
RN1310	USM	SC-70	SOT-323
RN1311	USM	SC-70	SOT-323
RN1312	USM	SC-70	SOT-323
RN1313	USM	SC-70	SOT-323
RN1314	USM	SC-70	SOT-323
RN1315	USM	SC-70	SOT-323
RN1316	USM	SC-70	SOT-323
RN1317	USM	SC-70	SOT-323
RN1318	USM	SC-70	SOT-323
RN1321A	USM	SC-70	SOT-323
RN1322A	USM	SC-70	SOT-323
RN1323A	USM	SC-70	SOT-323
RN1324A	USM	SC-70	SOT-323
RN1325A	USM	SC-70	SOT-323
RN1326A	USM	SC-70	SOT-323
RN1327A	USM	SC-70	SOT-323
RN2301	USM	SC-70	SOT-323
RN2302	USM	SC-70	SOT-323
RN2303	USM	SC-70	SOT-323
RN2304	USM	SC-70	SOT-323
RN2305	USM	SC-70	SOT-323
RN2306	USM	SC-70	SOT-323
RN2307	USM	SC-70	SOT-323
RN2308	USM	SC-70	SOT-323
RN2309	USM	SC-70	SOT-323
RN2310	USM	SC-70	SOT-323
RN2311	USM	SC-70	SOT-323
RN2312	USM	SC-70	SOT-323
RN2313	USM	SC-70	SOT-323
RN2314	USM	SC-70	SOT-323
RN2315	USM	SC-70	SOT-323
RN2316	USM	SC-70	SOT-323
RN2317	USM	SC-70	SOT-323
RN2318	USM	SC-70	SOT-323
RN2321A	USM	SC-70	SOT-323
RN2322A	USM	SC-70	SOT-323
RN2323A	USM	SC-70	SOT-323

■ Bias Resistor Built-in Transistors (Continued)

Part Number	Package		
	Toshiba	JEITA	–
RN2324A	USM	SC-70	SOT-323
RN2325A	USM	SC-70	SOT-323
RN2326A	USM	SC-70	SOT-323
RN2327A	USM	SC-70	SOT-323
RN1701	USV	SC-88A	SOT-353
RN1702	USV	SC-88A	SOT-353
RN1703	USV	SC-88A	SOT-353
RN1704	USV	SC-88A	SOT-353
RN1705	USV	SC-88A	SOT-353
RN1706	USV	SC-88A	SOT-353
RN1707	USV	SC-88A	SOT-353
RN1708	USV	SC-88A	SOT-353
RN1709	USV	SC-88A	SOT-353
RN1710	USV	SC-88A	SOT-353
RN1711	USV	SC-88A	SOT-353
RN2701	USV	SC-88A	SOT-353
RN2702	USV	SC-88A	SOT-353
RN2703	USV	SC-88A	SOT-353
RN2704	USV	SC-88A	SOT-353
RN2705	USV	SC-88A	SOT-353
RN2706	USV	SC-88A	SOT-353
RN2707	USV	SC-88A	SOT-353
RN2708	USV	SC-88A	SOT-353
RN2709	USV	SC-88A	SOT-353
RN2710	USV	SC-88A	SOT-353
RN2711	USV	SC-88A	SOT-353
RN2714	USV	SC-88A	SOT-353
RN47A1	USV	SC-88A	SOT-353
RN47A2	USV	SC-88A	SOT-353
RN47A3	USV	SC-88A	SOT-353
RN47A4	USV	SC-88A	SOT-353
RN47A5	USV	SC-88A	SOT-353
RN47A6	USV	SC-88A	SOT-353
RN1101MFV	VESM	SC-105AA	SOT-723
RN1102MFV	VESM	SC-105AA	SOT-723
RN1103MFV	VESM	SC-105AA	SOT-723
RN1104MFV	VESM	SC-105AA	SOT-723
RN1105MFV	VESM	SC-105AA	SOT-723
RN1106MFV	VESM	SC-105AA	SOT-723
RN1107MFV	VESM	SC-105AA	SOT-723
RN1108MFV	VESM	SC-105AA	SOT-723
RN1109MFV	VESM	SC-105AA	SOT-723
RN1110MFV	VESM	SC-105AA	SOT-723
RN1111MFV	VESM	SC-105AA	SOT-723
RN1112MFV	VESM	SC-105AA	SOT-723
RN1113MFV	VESM	SC-105AA	SOT-723
RN1114MFV	VESM	SC-105AA	SOT-723
RN1115MFV	VESM	SC-105AA	SOT-723
RN1116MFV	VESM	SC-105AA	SOT-723
RN1117MFV	VESM	SC-105AA	SOT-723
RN1118MFV	VESM	SC-105AA	SOT-723
RN1119MFV	VESM	SC-105AA	SOT-723
RN1130MFV	VESM	SC-105AA	SOT-723
RN1131MFV	VESM	SC-105AA	SOT-723
RN1132MFV	VESM	SC-105AA	SOT-723

Part Number	Package		
	Toshiba	JEITA	–
RN2101MFV	VESM	SC-105AA	SOT-723
RN2102MFV	VESM	SC-105AA	SOT-723
RN2103MFV	VESM	SC-105AA	SOT-723
RN2104MFV	VESM	SC-105AA	SOT-723
RN2105MFV	VESM	SC-105AA	SOT-723
RN2106MFV	VESM	SC-105AA	SOT-723
RN2107MFV	VESM	SC-105AA	SOT-723
RN2108MFV	VESM	SC-105AA	SOT-723
RN2109MFV	VESM	SC-105AA	SOT-723
RN2110MFV	VESM	SC-105AA	SOT-723
RN2111MFV	VESM	SC-105AA	SOT-723
RN2112MFV	VESM	SC-105AA	SOT-723
RN2113MFV	VESM	SC-105AA	SOT-723
RN2114MFV	VESM	SC-105AA	SOT-723
RN2115MFV	VESM	SC-105AA	SOT-723
RN2116MFV	VESM	SC-105AA	SOT-723
RN2117MFV	VESM	SC-105AA	SOT-723
RN2118MFV	VESM	SC-105AA	SOT-723
RN2119MFV	VESM	SC-105AA	SOT-723
RN2130MFV	VESM	SC-105AA	SOT-723
RN2131MFV	VESM	SC-105AA	SOT-723
RN2132MFV	VESM	SC-105AA	SOT-723

■ Multi-Chip Discrete Devices

Part Number	Package		
	Toshiba	JEITA	–
HN7G01FE	ES6	SC-107C	SOT-563
HN7G02FE	ES6	SC-107C	SOT-563
HN7G06FE	ES6	SC-107C	SOT-563
HN7G08FE	ES6	SC-107C	SOT-563
HN7G09FE	ES6	SC-107C	SOT-563
HN7G10FE	ES6	SC-107C	SOT-563
HN7G01FU	US6	SC-88	SOT-363
HN7G02FU	US6	SC-88	SOT-363
HN7G03FU	US6	SC-88	SOT-363
HN7G04FU	US6	SC-88	SOT-363
HN7G05FU	US6	SC-88	SOT-363
HN7G06FU	US6	SC-88	SOT-363
HN7G07FU	US6	SC-88	SOT-363

■ L-MOS (One-Gate CMOS)

Part Number	Package		
	Toshiba	JEITA	–
TC7SG00AFS	fSV	–	SOT-953
TC7SG02AFS	fSV	–	SOT-953
TC7SG04AFS	fSV	–	SOT-953
TC7SG05AFS	fSV	–	SOT-953
TC7SG07AFS	fSV	–	SOT-953
TC7SG08AFS	fSV	–	SOT-953
TC7SG125AFS	fSV	–	SOT-953
TC7SG126AFS	fSV	–	SOT-953
TC7SG14AFS	fSV	–	SOT-953
TC7SG17AFS	fSV	–	SOT-953
TC7SG32AFS	fSV	–	SOT-953

■ L-MOS (One-Gate CMOS) (Continued)

Part Number	Package		
	Toshiba	JEITA	–
TC7SG34AFS	fSV	–	SOT-953
TC7SG86AFS	fSV	–	SOT-953
TC7SGU04AFS	fSV	–	SOT-953
TC7SH00FS	fSV	–	SOT-953
TC7SH02FS	fSV	–	SOT-953
TC7SH04FS	fSV	–	SOT-953
TC7SH08FS	fSV	–	SOT-953
TC7SH125FS	fSV	–	SOT-953
TC7SH126FS	fSV	–	SOT-953
TC7SH14FS	fSV	–	SOT-953
TC7SH32FS	fSV	–	SOT-953
TC7SH34FS	fSV	–	SOT-953
TC7SH86FS	fSV	–	SOT-953
TC7SHU04FS	fSV	–	SOT-953
TC7SZ00AFS	fSV	–	SOT-953
TC7SZ02AFS	fSV	–	SOT-953
TC7SZ04AFS	fSV	–	SOT-953
TC7SZ05AFS	fSV	–	SOT-953
TC7SZ07AFS	fSV	–	SOT-953
TC7SZ08AFS	fSV	–	SOT-953
TC7SZ125AFS	fSV	–	SOT-953
TC7SZ126AFS	fSV	–	SOT-953
TC7SZ32AFS	fSV	–	SOT-953
TC7SZ34AFS	fSV	–	SOT-953
TC7SZU04AFS	fSV	–	SOT-953
TC4S66FU	USV	SC-88A	SOT-353
TC7S00FU	USV	SC-88A	SOT-353
TC7S02FU	USV	SC-88A	SOT-353
TC7S04FU	USV	SC-88A	SOT-353
TC7S08FU	USV	SC-88A	SOT-353
TC7S14FU	USV	SC-88A	SOT-353
TC7S32FU	USV	SC-88A	SOT-353
TC7S66FU	USV	SC-88A	SOT-353
TC7S86FU	USV	SC-88A	SOT-353
TC7SA00FU	USV	SC-88A	SOT-353
TC7SA04FU	USV	SC-88A	SOT-353
TC7SA05FU	USV	SC-88A	SOT-353
TC7SA08FU	USV	SC-88A	SOT-353
TC7SA32FU	USV	SC-88A	SOT-353
TC7SA34FU	USV	SC-88A	SOT-353
TC7SAU04FU	USV	SC-88A	SOT-353
TC7SET08FU	USV	SC-88A	SOT-353
TC7SET125FU	USV	SC-88A	SOT-353
TC7SET126FU	USV	SC-88A	SOT-353
TC7SET14FU	USV	SC-88A	SOT-353
TC7SET17FU	USV	SC-88A	SOT-353
TC7SET34FU	USV	SC-88A	SOT-353
TC7SG00FU	USV	SC-88A	SOT-353
TC7SG02FU	USV	SC-88A	SOT-353
TC7SG04FU	USV	SC-88A	SOT-353
TC7SG08FU	USV	SC-88A	SOT-353
TC7SG125FU	USV	SC-88A	SOT-353
TC7SG126FU	USV	SC-88A	SOT-353
TC7SG14FU	USV	SC-88A	SOT-353
TC7SG17FU	USV	SC-88A	SOT-353

Part Number	Package		
	Toshiba	JEITA	–
TC7SG32FU	USV	SC-88A	SOT-353
TC7SG34FU	USV	SC-88A	SOT-353
TC7SG79FU	USV	SC-88A	SOT-353
TC7SG80FU	USV	SC-88A	SOT-353
TC7SG86FU	USV	SC-88A	SOT-353
TC7SGU04FU	USV	SC-88A	SOT-353
TC7SH00FU	USV	SC-88A	SOT-353
TC7SH02FU	USV	SC-88A	SOT-353
TC7SH04FU	USV	SC-88A	SOT-353
TC7SH08FU	USV	SC-88A	SOT-353
TC7SH125FU	USV	SC-88A	SOT-353
TC7SH126FU	USV	SC-88A	SOT-353
TC7SH14FU	USV	SC-88A	SOT-353
TC7SH17FU	USV	SC-88A	SOT-353
TC7SH32FU	USV	SC-88A	SOT-353
TC7SH34FU	USV	SC-88A	SOT-353
TC7SH86FU	USV	SC-88A	SOT-353
TC7SHU04FU	USV	SC-88A	SOT-353
TC7SU04FU	USV	SC-88A	SOT-353
TC7SZ00FU	USV	SC-88A	SOT-353
TC7SZ02FU	USV	SC-88A	SOT-353
TC7SZ04FU	USV	SC-88A	SOT-353
TC7SZ05FU	USV	SC-88A	SOT-353
TC7SZ07FU	USV	SC-88A	SOT-353
TC7SZ08FU	USV	SC-88A	SOT-353
TC7SZ125FU	USV	SC-88A	SOT-353
TC7SZ126FU	USV	SC-88A	SOT-353
TC7SZ14FU	USV	SC-88A	SOT-353
TC7SZ17FU	USV	SC-88A	SOT-353
TC7SZ32FU	USV	SC-88A	SOT-353
TC7SZ34FU	USV	SC-88A	SOT-353
TC7SZ38FU	USV	SC-88A	SOT-353
TC7SZ86FU	USV	SC-88A	SOT-353
TC7SZU04FU	USV	SC-88A	SOT-353
TC4S01F	SMV	SC-74A	SOT-25
TC4S11F	SMV	SC-74A	SOT-25
TC4S30F	SMV	SC-74A	SOT-25
TC4S584F	SMV	SC-74A	SOT-25
TC4S66F	SMV	SC-74A	SOT-25
TC4S69F	SMV	SC-74A	SOT-25
TC4S71F	SMV	SC-74A	SOT-25
TC4S81F	SMV	SC-74A	SOT-25
TC4SU11F	SMV	SC-74A	SOT-25
TC7S04F	SMV	SC-74A	SOT-25
TC7S08F	SMV	SC-74A	SOT-25
TC7S14F	SMV	SC-74A	SOT-25
TC7S32F	SMV	SC-74A	SOT-25
TC7S66F	SMV	SC-74A	SOT-25
TC7S86F	SMV	SC-74A	SOT-25
TC7SET00F	SMV	SC-74A	SOT-25
TC7SET02F	SMV	SC-74A	SOT-25
TC7SET04F	SMV	SC-74A	SOT-25
TC7SET08F	SMV	SC-74A	SOT-25
TC7SET125F	SMV	SC-74A	SOT-25
TC7SET126F	SMV	SC-74A	SOT-25

Part Number	Package		
	Toshiba	JEITA	–
TC7SET14F	SMV	SC-74A	SOT-25
TC7SET32F	SMV	SC-74A	SOT-25
TC7SET34F	SMV	SC-74A	SOT-25
TC7SET86F	SMV	SC-74A	SOT-25
TC7SH00F	SMV	SC-74A	SOT-25
TC7SH02F	SMV	SC-74A	SOT-25
TC7SH04F	SMV	SC-74A	SOT-25
TC7SH08F	SMV	SC-74A	SOT-25
TC7SH125F	SMV	SC-74A	SOT-25
TC7SH126F	SMV	SC-74A	SOT-25
TC7SH14F	SMV	SC-74A	SOT-25
TC7SH17F	SMV	SC-74A	SOT-25
TC7SH32F	SMV	SC-74A	SOT-25
TC7SH34F	SMV	SC-74A	SOT-25
TC7SH86F	SMV	SC-74A	SOT-25
TC7SHU04F	SMV	SC-74A	SOT-25
TC7SU04F	SMV	SC-74A	SOT-25
TC7SZ00F	SMV	SC-74A	SOT-25
TC7SZ02F	SMV	SC-74A	SOT-25
TC7SZ04F	SMV	SC-74A	SOT-25
TC7SZ05F	SMV	SC-74A	SOT-25
TC7SZ07F	SMV	SC-74A	SOT-25
TC7SZ08F	SMV	SC-74A	SOT-25
TC7SZ125F	SMV	SC-74A	SOT-25
TC7SZ126F	SMV	SC-74A	SOT-25
TC7SZ14F	SMV	SC-74A	SOT-25
TC7SZ17F	SMV	SC-74A	SOT-25
TC7SZ32F	SMV	SC-74A	SOT-25
TC7SZ34F	SMV	SC-74A	SOT-25
TC7SZ38F	SMV	SC-74A	SOT-25
TC7SZ86F	SMV	SC-74A	SOT-25
TC7SZU04F	SMV	SC-74A	SOT-25
TC7PA04FU	US6	SC-88	SOT-363
TC7PA05FU	US6	SC-88	SOT-363
TC7PA14FU	US6	SC-88	SOT-363
TC7PA175FU	US6	SC-88	SOT-363
TC7PA17FU	US6	SC-88	SOT-363
TC7PA34FU	US6	SC-88	SOT-363
TC7PA53FU	US6	SC-88	SOT-363
TC7PAU04FU	US6	SC-88	SOT-363
TC7PGU04FU	US6	SC-88	SOT-363
TC7W00FK	US6	SC-88	SOT-363
TC7W02FK	US8	–	–
TC7W04FK	US8	–	–
TC7W08FK	US8	–	–
TC7W14FK	US8	–	–
TC7W32FK	US8	–	–
TC7W34FK	US8	–	–
TC7W53FK	US8	–	–
TC7W66FK	US8	–	–
TC7W74FK	US8	–	–
TC7WG00FK	US8	–	–
TC7WG02FK	US8	–	–
TC7WG04FK	US8	–	–
TC7WG08FK	US8	–	–

Part Number	Package		
	Toshiba	JEITA	–
TC7WG32FK	US8	–	–
TC7WG34FK	US8	–	–
TC7WG74FK	US8	–	–
TC7WGU04FK	US8	–	–
TC7WH00FK	US8	–	–
TC7WH02FK	US8	–	–
TC7WH04FK	US8	–	–
TC7WH08FK	US8	–	–
TC7WH123FK	US8	–	–
TC7WH125FK	US8	–	–
TC7WH126FK	US8	–	–
TC7WH14FK	US8	–	–
TC7WH157FK	US8	–	–
TC7WH240FK	US8	–	–
TC7WH241FK	US8	–	–
TC7WH245FK	US8	–	–
TC7WH32FK	US8	–	–
TC7WH34FK	US8	–	–
TC7WH74FK	US8	–	–
TC7WHU04FK	US8	–	–
TC7WU04FK	US8	–	–
TC7WZ00FK	US8	–	–
TC7WZ02FK	US8	–	–
TC7WZ04FK	US8	–	–
TC7WZ05FK	US8	–	–
TC7WZ08FK	US8	–	–
TC7WZ125FK	US8	–	–
TC7WZ126FK	US8	–	–
TC7WZ14FK	US8	–	–
TC7WZ245FK	US8	–	–
TC7WZ246FK	US8	–	–
TC7WZ32FK	US8	–	–
TC7WZ34FK	US8	–	–
TC7WZ38FK	US8	–	–
TC7WZ74FK	US8	–	–
TC7WZU04FK	US8	–	–
TC7W53FU	SM8	–	SOT-505
TC7WH126FU	SM8	–	SOT-505

■ LDO (Low-Dropout Regulators)

Part Number	Package		
	Toshiba	JEITA	–
TCR5SB15A	SMV	SC-74A	SOT-25
TCR5SB16A	SMV	SC-74A	SOT-25
TCR5SB17A	SMV	SC-74A	SOT-25
TCR5SB18A	SMV	SC-74A	SOT-25
TCR5SB19A	SMV	SC-74A	SOT-25
TCR5SB20A	SMV	SC-74A	SOT-25
TCR5SB21A	SMV	SC-74A	SOT-25
TCR5SB22A	SMV	SC-74A	SOT-25
TCR5SB23A	SMV	SC-74A	SOT-25
TCR5SB24A	SMV	SC-74A	SOT-25
TCR5SB25A	SMV	SC-74A	SOT-25
TCR5SB26A	SMV	SC-74A	SOT-25
TCR5SB27A	SMV	SC-74A	SOT-25
TCR5SB28A	SMV	SC-74A	SOT-25
TCR5SB29A	SMV	SC-74A	SOT-25
TCR5SB30A	SMV	SC-74A	SOT-25
TCR5SB31A	SMV	SC-74A	SOT-25
TCR5SB32A	SMV	SC-74A	SOT-25
TCR5SB33A	SMV	SC-74A	SOT-25
TCR5SB34A	SMV	SC-74A	SOT-25
TCR5SB35A	SMV	SC-74A	SOT-25
TCR5SB36A	SMV	SC-74A	SOT-25
TCR5SB37A	SMV	SC-74A	SOT-25
TCR5SB38A	SMV	SC-74A	SOT-25
TCR5SB39A	SMV	SC-74A	SOT-25
TCR5SB40A	SMV	SC-74A	SOT-25
TCR5SB41A	SMV	SC-74A	SOT-25
TCR5SB42A	SMV	SC-74A	SOT-25
TCR5SB43A	SMV	SC-74A	SOT-25
TCR5SB44A	SMV	SC-74A	SOT-25
TCR5SB45A	SMV	SC-74A	SOT-25
TCR5SB46A	SMV	SC-74A	SOT-25
TCR5SB47A	SMV	SC-74A	SOT-25
TCR5SB48A	SMV	SC-74A	SOT-25
TCR5SB49A	SMV	SC-74A	SOT-25
TCR5SB50A	SMV	SC-74A	SOT-25

■ Small-Signal MOSFETs

Part Number	Package		
	Toshiba	JEITA	–
SSM6N16FE	ES6	–	SOT-563
SSM6N36FE	ES6	–	SOT-563
2SJ343	S-Mini	SC-59	SOT-346
SSM3J15F	S-Mini	SC-59	SOT-346
SSM3J325F	S-Mini	SC-59	SOT-346
SSM3J327F	S-Mini	SC-59	SOT-346
SSM3K15F	S-Mini	SC-59	SOT-346
SSM3K7002AF	S-Mini	SC-59	SOT-346
SSM3K7002BF	S-Mini	SC-59	SOT-346
SSM3K7002F	S-Mini	SC-59	SOT-346
SSM3J327R	SOT-23F	–	–
SSM3J328R	SOT-23F	–	–
SSM3J332R	SOT-23F	–	–
SSM3J334R	SOT-23F	–	–
SSM3K329R	SOT-23F	–	–
SSM3K333R	SOT-23F	–	–
SSM3K7002BR	SOT-23F	–	–

Part Number	Package		
	Toshiba	JEITA	–
SSM3J15FS	SSM	SC-75	SOT-416
SSM3J16FS	SSM	SC-75	SOT-416
SSM3J35FS	SSM	SC-75	SOT-416
SSM3J36FS	SSM	SC-75	SOT-416
SSM3K04FS	SSM	SC-75	SOT-416
SSM3K16FS	SSM	SC-75	SOT-416
SSM3K35FS	SSM	SC-75	SOT-416
SSM3K36FS	SSM	SC-75	SOT-416
SSM3K43FS	SSM	SC-75	SOT-416
SSM3K44FS	SSM	SC-75	SOT-416
SSM3K7002BFS	SSM	SC-75	SOT-416
SSM3J01T	TSM	–	–
SSM3J02T	TSM	–	–
SSM3J13T	TSM	–	–
SSM3J14T	TSM	–	–
SSM3J304T	TSM	–	–
SSM3J305T	TSM	–	–
SSM3J306T	TSM	–	–
SSM3J307T	TSM	–	–
SSM3J312T	TSM	–	–
SSM3J313T	TSM	–	–
SSM3J314T	TSM	–	–
SSM3J317T	TSM	–	–
SSM3J321T	TSM	–	–
SSM3J326T	TSM	–	–
SSM3K01T	TSM	–	–
SSM3K02T	TSM	–	–
SSM3K12T	TSM	–	–
SSM3K14T	TSM	–	–
SSM3K301T	TSM	–	–
SSM3K302T	TSM	–	–
SSM3K303T	TSM	–	–
SSM3K309T	TSM	–	–
SSM3K310T	TSM	–	–
SSM3K315T	TSM	–	–
SSM3K316T	TSM	–	–
SSM3K318T	TSM	–	–
SSM3K320T	TSM	–	–
SSM6G13NU	UDFN6	–	–
SSM6G18NU	UDFN6	–	–
SSM6P49NU	UDFN6	–	–
SSM6J501NU	UDFN6B	–	–
SSM6J502NU	UDFN6B	–	–
SSM6J503NU	UDFN6B	–	–
SSM6E01TU	UF6	–	–
SSM6J21TU	UF6	–	–
SSM6J401TU	UF6	–	–
SSM6J50TU	UF6	–	–
SSM6J51TU	UF6	–	–
SSM6K406TU	UF6	–	–
SSM6L12TU	UF6	–	–
SSM6L13TU	UF6	–	–
SSM6L39TU	UF6	–	–
SSM6N24TU	UF6	–	–
SSM6N25TU	UF6	–	–
SSM6P28TU	UF6	–	–
SSM6P54TU	UF6	–	–

Part Number	Package		
	Toshiba	JEITA	–
SSM3J108TU	UFM	–	–
SSM3J109TU	UFM	–	–
SSM3J110TU	UFM	–	–
SSM3J111TU	UFM	–	–
SSM3J112TU	UFM	–	–
SSM3J113TU	UFM	–	–
SSM3J114TU	UFM	–	–
SSM3J115TU	UFM	–	–
SSM3J117TU	UFM	–	–
SSM3J118TU	UFM	–	–
SSM3J120TU	UFM	–	–
SSM3J129TU	UFM	–	–
SSM3J130TU	UFM	–	–
SSM3J36TU	UFM	–	–
SSM3K101TU	UFM	–	–
SSM3K102TU	UFM	–	–
SSM3K104TU	UFM	–	–
SSM3K105TU	UFM	–	–
SSM3K106TU	UFM	–	–
SSM3K107TU	UFM	–	–
SSM3K116TU	UFM	–	–
SSM3K119TU	UFM	–	–
SSM3K121TU	UFM	–	–
SSM3K122TU	UFM	–	–
SSM3K123TU	UFM	–	–
SSM3K124TU	UFM	–	–
SSM3K125TU	UFM	–	–
SSM3K126TU	UFM	–	–
SSM3K127TU	UFM	–	–
SSM3K128TU	UFM	–	–
SSM3K131TU	UFM	–	–
SSM3K36TU	UFM	–	–
SSM5G04TU	UFV	–	–
SSM5H08TU	UFV	–	–
SSM5H16TU	UFV	–	–
SSM5H90TU	UFV	–	–
SSM6N09FU	US6	SC-88	SOT-363
SSM6N15FU	US6	SC-88	SOT-363
SSM6N16FU	US6	SC-88	SOT-363
SSM6N17FU	US6	SC-88	SOT-363
SSM6N43FU	US6	SC-88	SOT-363
SSM6N44FU	US6	SC-88	SOT-363
SSM6N7002BFU	US6	SC-88	SOT-363
SSM6N7002FU	US6	SC-88	SOT-363
SSM6P05FU	US6	SC-88	SOT-363
SSM6P09FU	US6	SC-88	SOT-363
SSM6P15FU	US6	SC-88	SOT-363
2SJ344	USM	SC-70	SOT-323
SSM3J05FU	USM	SC-70	SOT-323
SSM3J09FU	USM	SC-70	SOT-323
SSM3J15FU	USM	SC-70	SOT-323
SSM3J16FU	USM	SC-70	SOT-323
SSM3K04FU	USM	SC-70	SOT-323
SSM3K05FU	USM	SC-70	SOT-323
SSM3K09FU	USM	SC-70	SOT-323
SSM3K15FU	USM	SC-70	SOT-323
SSM3K16FU	USM	SC-70	SOT-323

Part Number	Package		
	Toshiba	JEITA	–
SSM3K17FU	USM	SC-70	SOT-323
SSM3K7002AFU	USM	SC-70	SOT-323
SSM3K7002BFU	USM	SC-70	SOT-323
SSM3K7002FU	USM	SC-70	SOT-323
SSM5N05FU	USV	SC-88A	SOT-353
SSM5N15FU	USV	SC-88A	SOT-353
SSM5N16FU	USV	SC-88A	SOT-353
SSM5P05FU	USV	SC-88A	SOT-353
SSM5P15FU	USV	SC-88A	SOT-353
SSM5P16FU	USV	SC-88A	SOT-353
2SK4059MFV	VESM	SC-105AA	SOT-723
SSM3J15FV	VESM	SC-105AA	SOT-723
SSM3J16FV	VESM	SC-105AA	SOT-723
SSM3J35MFV	VESM	SC-105AA	SOT-723
SSM3J36MFV	VESM	SC-105AA	SOT-723
SSM3K15FV	VESM	SC-105AA	SOT-723
SSM3K16FV	VESM	SC-105AA	SOT-723
SSM3K37MFV	VESM	SC-105AA	SOT-723

■ Magnetic Sensors

Part Number	Package		
	Toshiba	JEITA	–
TCS20DLR	SOT-23F	–	–
TCS20DPR	SOT-23F	–	–

■ Op Amp and Comparator ICs

Part Number	Package		
	Toshiba	JEITA	–
TC75S51FU	USV	SC-88A	SOT-353
TC75S54FU	USV	SC-88A	SOT-353
TC75S55FU	USV	SC-88A	SOT-353
TC75S56FU	USV	SC-88A	SOT-353
TC75S57FU	USV	SC-88A	SOT-353
TC75S58FU	USV	SC-88A	SOT-353
TC75S59FU	USV	SC-88A	SOT-353
TC75S60FU	USV	SC-88A	SOT-353
TC75S101FU	USV	SC-88A	SOT-353
TC75W51FK	US8	–	–
TC75W54FK	US8	–	–
TC75W55FK	US8	–	–
TC75W56FK	US8	–	–
TC75W57FK	US8	–	–
TC75W58FK	US8	–	–
TC75W59FK	US8	–	–
TC75W60FK	US8	–	–
TA75W01FU	SM8	–	SOT-505
TA75W558FU	SM8	–	SOT-505
TA75W393FU	SM8	–	SOT-505
TC75W51FU	SM8	–	SOT-505
TC75W54FU	SM8	–	SOT-505
TC75W55FU	SM8	–	SOT-505
TC75W56FU	SM8	–	SOT-505
TC75W57FU	SM8	–	SOT-505
TC75W58FU	SM8	–	SOT-505
TC75W59FU	SM8	–	SOT-505
TC75W60FU	SM8	–	SOT-505

List of the Recommended New Devices

Predecessor		Recommended Replacement Device	Compatibility
Diode	1SS421	CES521	Electrically identical
Diode	1SS420	CES520	Electrically identical
Transistor	2SC4116	TTC4116FU	Electrically identical
Transistor	2SA1586	TTA1586FU	Electrically identical
MOSFET	SSM3K7002FU	SSM3K7002BFU	Electrically identical
MOSFET	SSM3K7002F	SSM3K7002BF	Electrically identical
MOSFET	SSM6N7002FU	SSM6N7002BFU	Electrically identical
MOSFET	SSM6N7002AFU	SSM6N7002BFU	Electrically identical
MOSFET	SSM3K15CT	SSM3K15ACT	Electrically identical
MOSFET	SSM3K15FS	SSM3K15AFS	Electrically identical
MOSFET	SSM3K15TE	SSM3K15AMFV	Electrically similar (The replacement device is housed in a smaller package.)
MOSFET	SSM3K15FV	SSM3K15AMFV	Electrically identical
MOSFET	SSM3K15FU	SSM3K15AFU	Electrically identical
MOSFET	SSM6N15FE	SSM6N15AFE	Electrically identical
MOSFET	SSM6N15FU	SSM6N15AFU	Electrically identical
MOSFET	SSM3K16CT	SSM3K37CT	Electrically identical
MOSFET	SSM3K16FS	SSM3K37FS	Electrically identical
MOSFET	SSM3K16TE	SSM3K37MFV	Electrically similar (The replacement device is housed in a smaller package.)
MOSFET	SSM3K16FV	SSM3K37MFV	Electrically identical
MOSFET	SSM6N16FU	SSM6N37FU	Electrically identical
LMOS	TC7SZxxAFE	TC7SZxxFE	Electrically identical
MOSFET	SSM6L16FE	SSM6L35FE	Electrically similar
MOSFET	SSM6L16FU	SSM6L35FU	Electrically similar
MOSFET	SSM3J16CT	SSM3J35CT	Electrically similar
MOSFET	SSM3J16FS	SSM3J35FS	Electrically similar
MOSFET	SSM3J16TE	SSM3J35MFV	Electrically similar (The replacement device is housed in a smaller package.)
MOSFET	SSM3J16MFV	SSM3J35MFV	Electrically similar
MOSFET	SSM6P16FE	SSM6P35FE	Electrically similar
MOSFET	SSM6P16FU	SSM6P35FU	Electrically similar
MOSFET	SSM3K05FU	SSM3K36TU	Electrically similar
MOSFET	SSM3J05FU	SSM3J36TU	Electrically identical
MOSFET	SSM6N05FU	SSM6N36TU	Electrically similar
MOSFET	SSM6P05FU	SSM6P36TU	Electrically identical
MOSFET	SSM6L05FU	SSM6L36TU	Electrically identical
MOSFET	SSM3K03FS	SSM3K44FS	Electrically similar
MOSFET	SSM3K03TE	SSM3K35MFV	Electrically similar (The replacement device is housed in a smaller package.)
MOSFET	SSM3K36FS	SSM3K43FS	Electrically similar
MOSFET	SSM6N36TU	SSM6N43FU	Electrically similar
MOSFET	SSM6N25TU	SSM6N39TU	Electrically similar
MOSFET	SSM6P25TU	SSM6P39TU	Electrically similar
MOSFET	SSM6P28TU	SSM6P39TU	Electrically similar
MOSFET	SSM6N29TU	SSM6N39TU	Electrically similar
MOSFET	SSM6L10TU	SSM6L39TU	Electrically similar
MOSFET	SSM6L13TU	SSM6L39TU	Electrically similar
MOSFET	SSM6J53FE	SSM6J214FE	Electrically identical
MOSFET	SSM6J51TU	SSM6J412TU	Electrically identical
MOSFET	SSM6J206FE	SSM6J213FE	Electrically identical
MOSFET	SSM5H12TU	SSM5H16TU	Electrically similar
MOSFET	SSM3K316T	SSM3K324R	Electrically similar (The replacement device is housed in a smaller package.)
MOSFET	SSM3K315T	SSM3K333R	Electrically similar (The replacement device is housed in a smaller package.)
MOSFET	SSM3K303T	SSM3K320T	Electrically identical
MOSFET	SSM3K14T	SSM3K320T	Electrically identical
MOSFET	SSM3K12T	SSM3K320T	Electrically identical
MOSFET	SSM3J317T	SSM3J327R	Electrically identical
MOSFET	SSM3J307T	SSM3J328R	Electrically similar (The replacement device is housed in a smaller package.)
MOSFET	SSM3J304T	SSM3J325F	Electrically identical
MOSFET	SSM3J14T	SSM3J334R	Electrically similar (The replacement device is housed in a smaller package.)
MOSFET	SSM3J120TU	SSM3J133TU	Electrically identical
MOSFET	SSM3J108TU	SSM3J134TU	Electrically identical
MOSFET	HN1K02FU	SSM6N44FU	Electrically similar
MOSFET	HN1L02FU	SSM6L35FU	Electrically similar
MOSFET	HN1K03FU	SSM6N44FU	Electrically similar
MOSFET	HN1K06FU	SSM6N35FU	Electrically similar

Predecessor		Recommended Replacement Device	Compatibility
MOSFET	HN1K06FU	SSM6N44FU	Electrically similar
MOSFET	2SK2035	SSM3K44FS	Electrically similar
MOSFET	2SK1830	SSM3K44FS	Electrically similar
LDO	TAR5Sxx	TCR5SBxxA	Electrically similar (Different pin assignments)
LDO	TAR5SxxU	TCR5SBxxU	Electrically similar (Different pin assignments)
LDO	TAR5SBxx	TCR5SBxxA	Electrically similar (Different pin assignments)
Diode	02CZ3.3	DF3A3.3FU	Electrically similar (The replacement device is housed in a smaller package.)(Note)
Diode	02CZ3.6	DF3A3.6FU	Electrically similar (The replacement device is housed in a smaller package.)(Note)
Diode	02CZ4.3	DF3A4.3FU	Electrically similar (The replacement device is housed in a smaller package.)(Note)
Diode	02CZ5.6	DF3A5.6F	Electrically similar (Note)
Diode	02CZ6.2	DF3A6.2F	Electrically similar (Note)
Diode	02CZ6.8	DF3A6.8F	Electrically similar (Note)
Diode	02DZ5.6	DF2S5.6FS	Electrically similar (The replacement device is housed in a smaller package.)(Note)
Diode	02DZ6.2	DF2S6.2FS	Electrically similar (The replacement device is housed in a smaller package.)(Note)
Diode	02DZ6.8	DF2S6.8FS	Electrically similar (The replacement device is housed in a smaller package.)(Note)
Diode	02DZ10	DF2S10FS	Electrically similar (The replacement device is housed in a smaller package.)(Note)
Diode	02DZ12	DF2S12FU	Electrically similar (Note)
Diode	02DZ16	DF2S16FS	Electrically similar (The replacement device is housed in a smaller package.)(Note)
Diode	02DZ20	DF2S20FS	Electrically similar (The replacement device is housed in a smaller package.)(Note)
Diode	02DZ22	DF2S24FS	Electrically similar (The replacement device is housed in a smaller package.)(Note)
Diode	015CZ5.6	DF2S5.6FS	Electrically similar (The replacement device is housed in a smaller package.)(Note)
Diode	015CZ6.2	DF2S6.2FS	Electrically similar (The replacement device is housed in a smaller package.)(Note)
Diode	015CZ6.8	DF2S6.8FS	Electrically similar (The replacement device is housed in a smaller package.)(Note)
Diode	015CZ10	DF2S10FS	Electrically similar (The replacement device is housed in a smaller package.)(Note)
Diode	015CZ12	DF2S12FS	Electrically similar (The replacement device is housed in a smaller package.)(Note)
Diode	015CZ16	DF2S16FS	Electrically similar (The replacement device is housed in a smaller package.)(Note)
Diode	015CZ20	DF2S20FS	Electrically similar (The replacement device is housed in a smaller package.)(Note)
Diode	015CZ22	DF2S24FS	Electrically similar (The replacement device is housed in a smaller package.)(Note)
Diode	015DZ5.6	DF2S5.6FS	Electrically similar
Diode	015DZ6.2	DF2S6.2FS	Electrically similar
Diode	015DZ6.8	DF2S6.8FS	Electrically similar
Diode	015DZ10	DF2S10FS	Electrically similar
Diode	015DZ12	DF2S12FS	Electrically similar
Diode	015DZ16	DF2S16FS	Electrically similar
Diode	015DZ20	DF2S20FS	Electrically similar
Diode	015DZ22	DF2S24FS	Electrically similar
Transistor	2SC1815	TTC4116FU	Electrically similar (The replacement device is housed in a smaller package.)
Transistor	2SA1015	TTA1586FU	Electrically similar (The replacement device is housed in a smaller package.)
Transistor	2SC1959	2SC2859	Electrically similar (The replacement device is housed in a smaller package.)
Transistor	2SA562TM	2SA1182	Electrically similar (The replacement device is housed in a smaller package.)
Transistor	2SC2120	2SC4210	Electrically similar (The replacement device is housed in a smaller package.)
Transistor	2SA950	2SA1621	Electrically similar (The replacement device is housed in a smaller package.)
Transistor	2SC1627	2SC4209	Electrically similar (The replacement device is housed in a smaller package.)
Transistor	2SA817	2SA1620	Electrically similar (The replacement device is housed in a smaller package.)
Transistor	2SC3112	2SC3295	Electrically similar (The replacement device is housed in a smaller package.)
Transistor	2SC2878	2SC3326	Electrically similar (The replacement device is housed in a smaller package.)
Transistor	2SC2551	2SC4497	Electrically similar (The replacement device is housed in a smaller package.)
Transistor	2SA1091	2SA1721	Electrically similar (The replacement device is housed in a smaller package.)

Note: The replacement devices are specifically designed for ESD protection and should not be used for any other purpose.





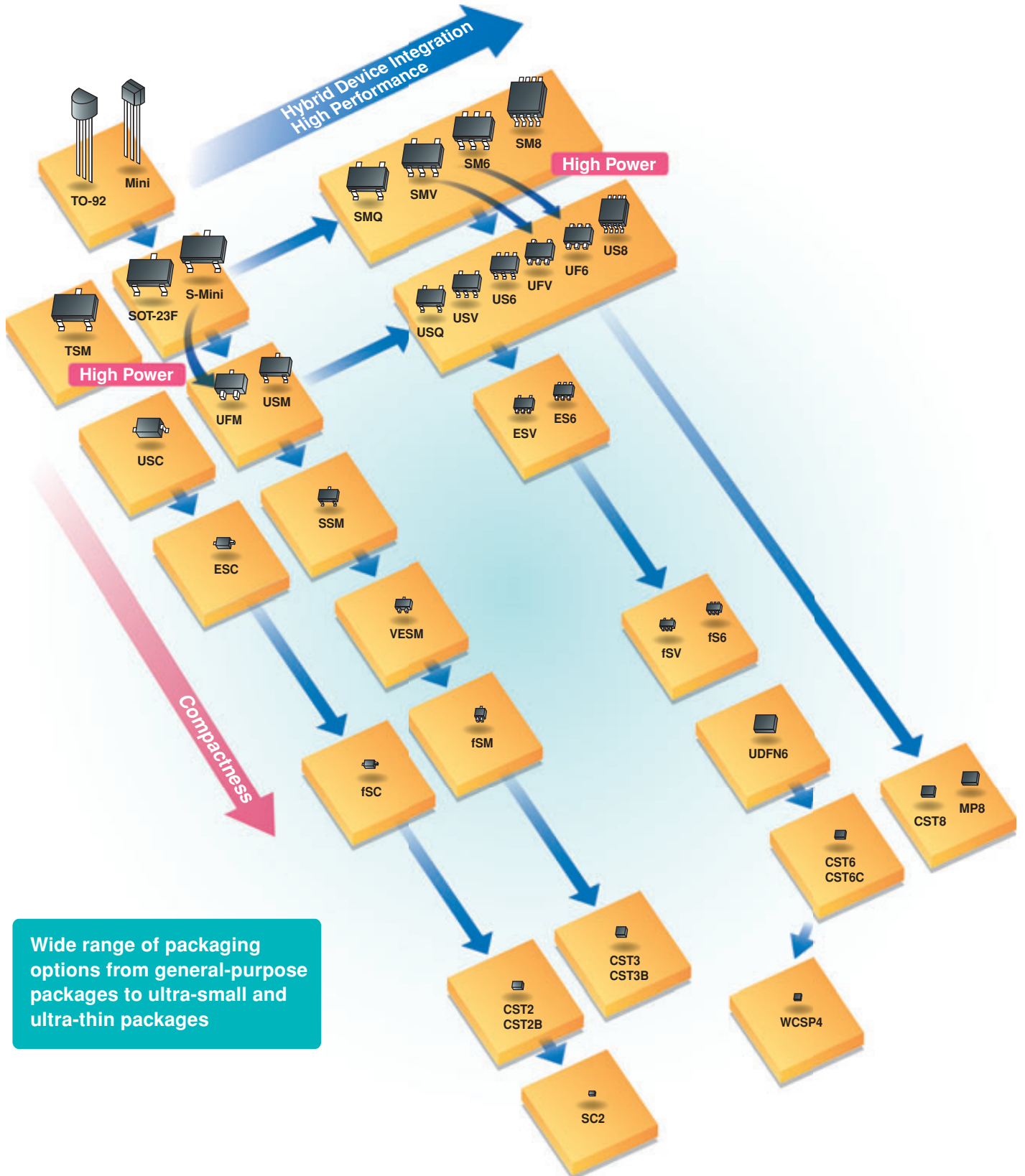





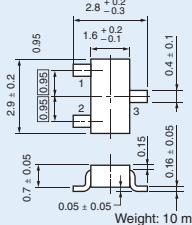
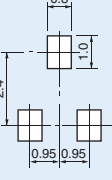
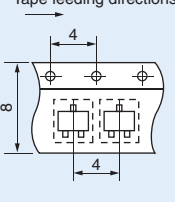
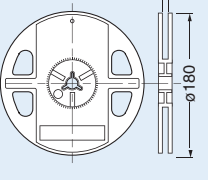

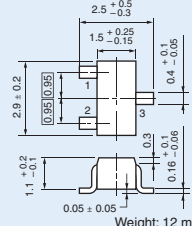
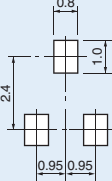
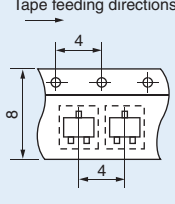
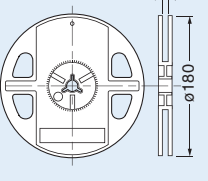
12 Packaging Information

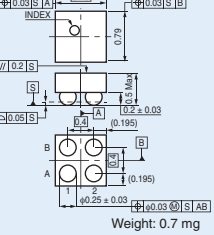
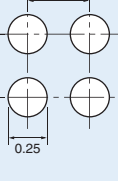
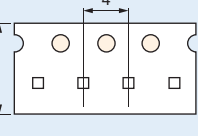
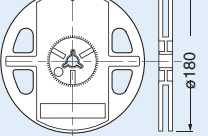
Packaging Roadmap for Surface-Mount Devices

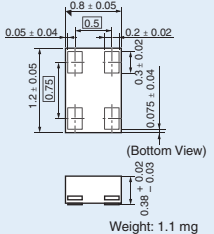
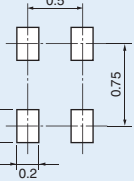
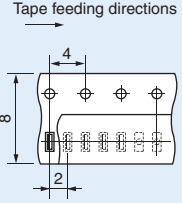
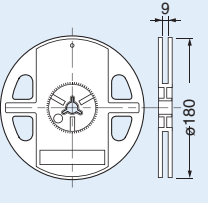

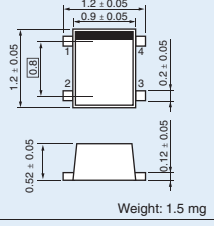
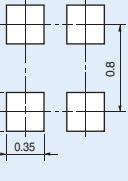
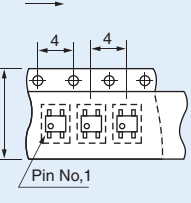
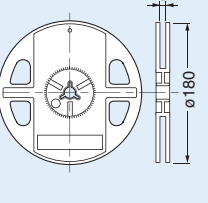

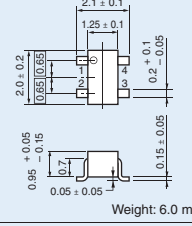
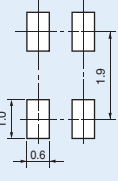
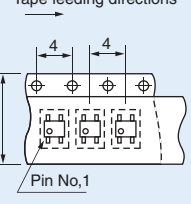
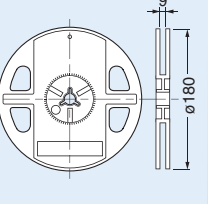

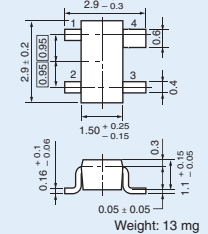
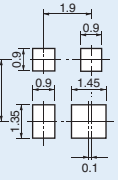
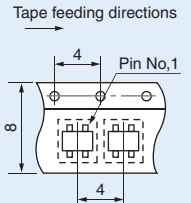
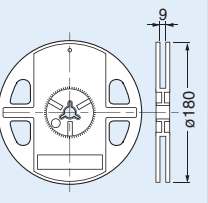





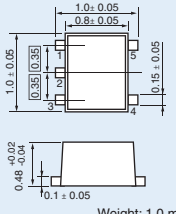
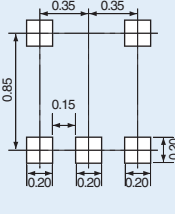
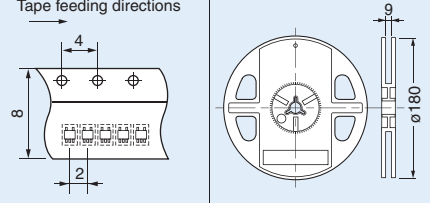

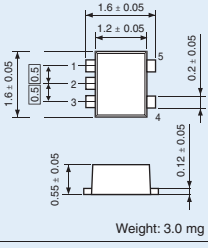
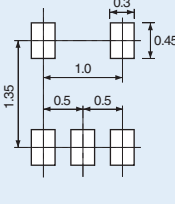
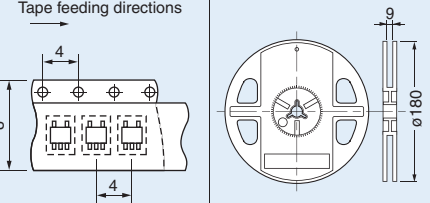
Toshiba Package Name	Package		Land Pattern Examples* Unit: mm	Standard Tape Packing Specifications		
	Appearance	Dimensions Unit: mm		Tape Type	Tape Dimensions Unit: mm	Reel Dimension Unit: mm
SC2		 0.19 ± 0.02 0.62 ± 0.03 0.32 ± 0.03 0.19 ± 0.02 0.27 ± 0.02 0.3 ± 0.03 0.19 ± 0.02 0.38 (Bottom View) Weight: 0.17 mg		TPL3	 Tape feeding directions 8.0 1.75 4.0 ± 0.05 3.5 ± 0.05 2.0 ± 0.05	 ø180
Packing quantity 10000/reel						
CST2 (SOD-882)		 0.75 0.5 ± 0.05 0.2 ± 0.05 1.0 ± 0.05 0.6 ± 0.05 (Bottom View) 0.38 ± 0.03 Weight: 0.7 mg		TPL3	 Tape feeding directions 4 8 2	 ø180
Packing quantity 10000/reel						
CST2B		 Cathode Mark 0.7 ± 0.02 1.2 ± 0.05 0.8 ± 0.05 0.05 0.05 0.25 ± 0.02 0.65 ± 0.02 (Bottom View) 0.38 ± 0.03 Weight: 0.7 mg		TPL3	 Tape feeding directions 4 8 2	 ø180
Packing quantity 10000/reel						
fSC		 Cathode Mark 0.6 ± 0.05 0.1 0.8 ± 0.05 0.2 ± 0.05 0.07 0.1 ± 0.05 0.48 ± 0.02 0.03 Weight: 0.6 mg		TPL3	 Tape feeding directions 4 8 2	 ø180
Packing quantity 10000/reel						
ESC (SOD-523)		 Cathode Mark 0.6 ± 0.1 0.2 1.2 ± 0.1 1.6 ± 0.1 0.3 ± 0.05 0.2 0.13 ± 0.05 0.8 ± 0.1 Weight: 1.4 mg		TPL3	 Tape feeding directions 4 8 2	 ø180
Packing quantity 8000/reel						
USC (SOD-323)		 Cathode marking 1.25 ± 0.2 0.1 1.7 ± 0.2 2.5 ± 0.2 0.3 ± 0.05 0.15 ± 0.1 0.9 ± 0.2 0.05 ± 0.05 Weight: 4.5 mg		TPH3	 Tape feeding directions 4 8 4	 ø180
Packing quantity 3000/reel						
CST3 (SOT-882)		 0.6 ± 0.05 1.0 ± 0.05 0.65 ± 0.02 0.5 ± 0.03 0.05 ± 0.03 0.25 ± 0.03 0.15 ± 0.03 0.35 ± 0.02 (Bottom View) 0.38 ± 0.02 0.38 ± 0.03 Weight: 0.75 mg		TPL3	 Tape feeding directions 4 8 2	 ø180
Packing quantity 10000/reel						

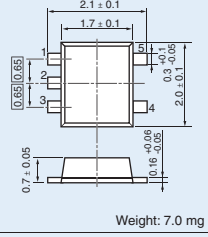
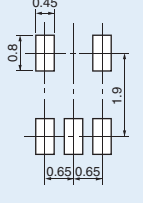
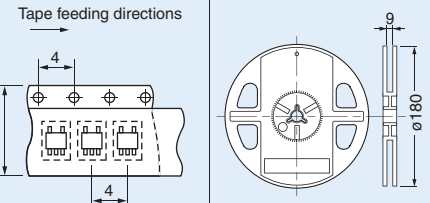
Note: For reference only. Be sure to verify device mountability.

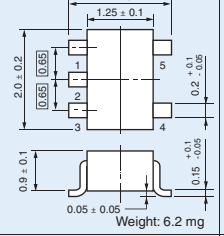
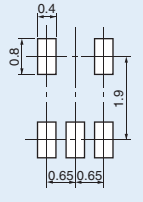
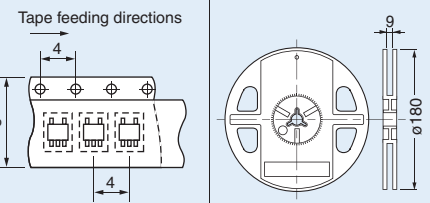

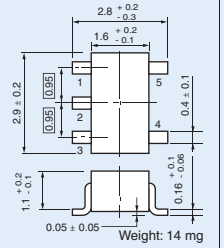
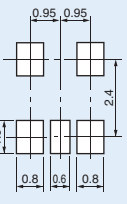
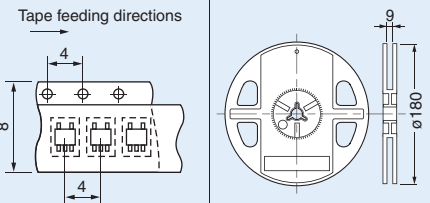

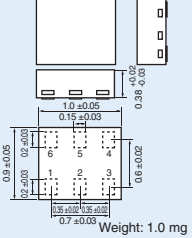
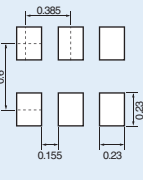
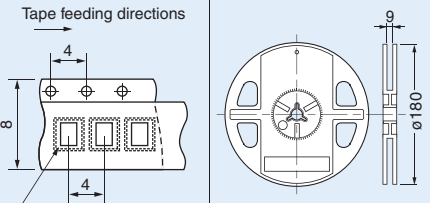

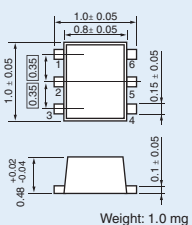
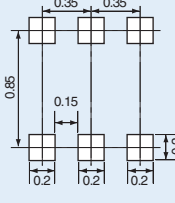
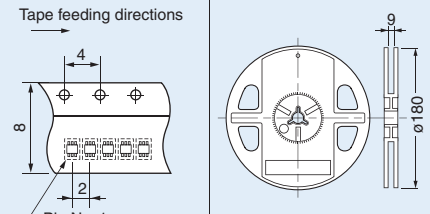



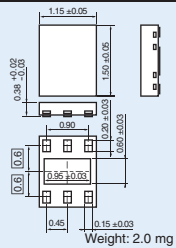
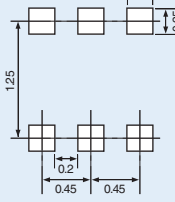
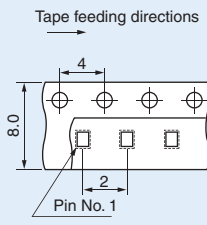
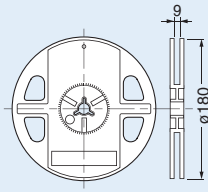

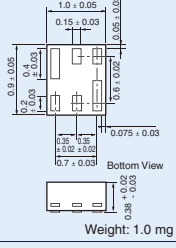
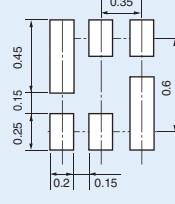
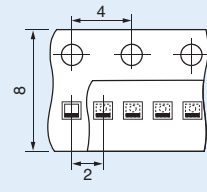
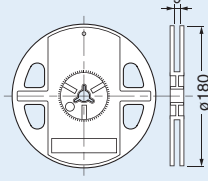
Toshiba Package Name	Package		Land Pattern Examples* Unit: mm	Standard Tape Packing Specifications		
	Appearance	Dimensions Unit: mm		Tape Type	Tape Dimensions Unit: mm	Reel Dimension Unit: mm
TSM		 Weight: 10 mg		TE85L		
Packing quantity 3000/reel						
S-Mini (SOT-346) (SC-59A)		 Weight: 12 mg		TE85L		
Packing quantity 3000/reel						
WCSP4		 Weight: 0.7 mg		TE85L		
Packing quantity 3000/reel						
CST4		 Weight: 1.1 mg		TPL3		
Packing quantity 10000/reel						
TESQ		 Weight: 1.5 mg		TE85L		
Packing quantity 4000/reel						
USQ (SOT-343) (SC-82)		 Weight: 6.0 mg		TE85L		
Packing quantity 3000/reel						
SMQ (SOT-24) (SC-61)		 Weight: 13 mg		TE85L		
Packing quantity 3000/reel						

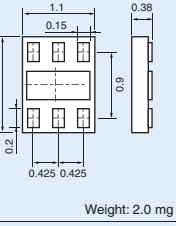
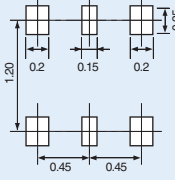
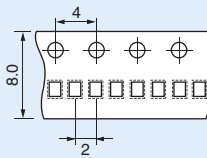
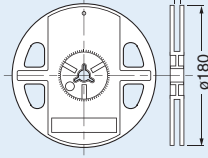
Note: For reference only. Be sure to verify device mountability.

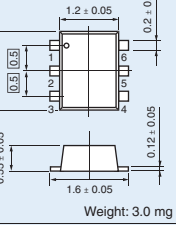
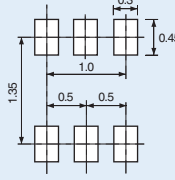
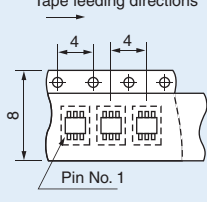
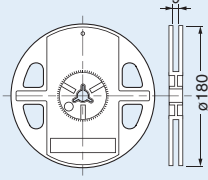
12 Packaging Information

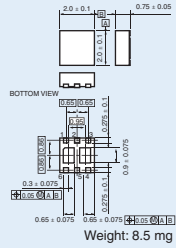
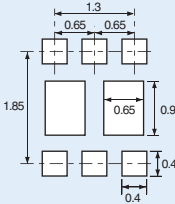
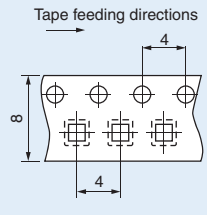
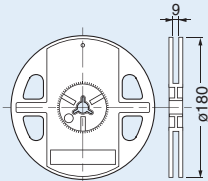

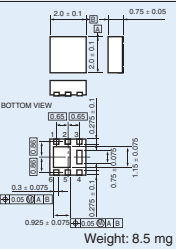
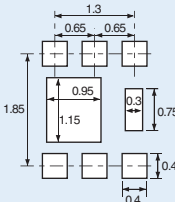
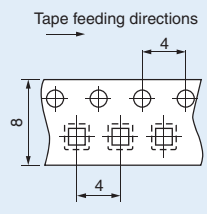
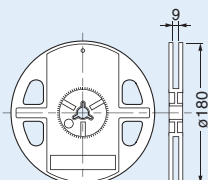

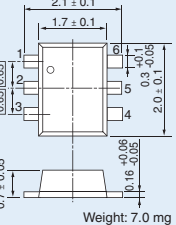
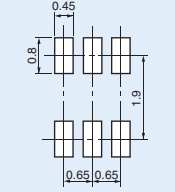
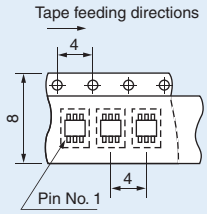
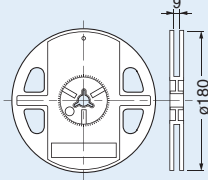





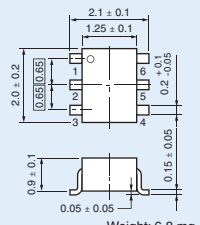
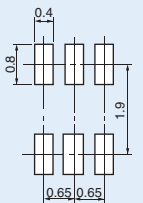
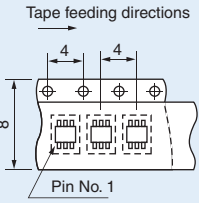
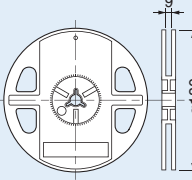

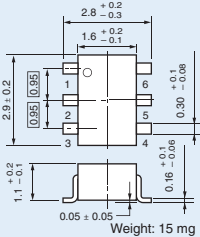
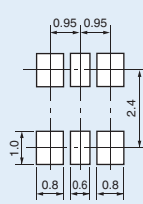
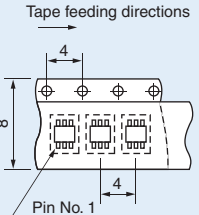
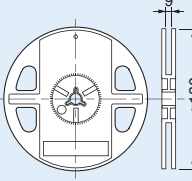
Toshiba Package Name	Package		Land Pattern Examples* Unit: mm	Standard Tape Packing Specifications		
	Appearance	Dimensions Unit: mm		Tape Type	Tape Dimensions Unit: mm	Reel Dimension Unit: mm
fSV (SOT-953)		 Weight: 1.0 mg		TPL3		
Packing quantity 10000/reel						
ESV (SOT-553) (SC-107BB)		 Weight: 3.0 mg		TE85L		
Packing quantity 4000/reel						
UFV		 Weight: 7.0 mg		TE85L		
Packing quantity 3000/reel						
USV (SOT-353) (SC-88A)		 Weight: 6.2 mg		TE85L		
Packing quantity 3000/reel						
SMV (SOT-25) (SC-74A)		 Weight: 14 mg		TE85L		
Packing quantity 3000/reel						
CST6		 Weight: 1.0 mg		TPL3		
Packing quantity 10000/reel						
fS6 (SOT-963)		 Weight: 1.0 mg		TPL3		
Packing quantity 10000/reel						

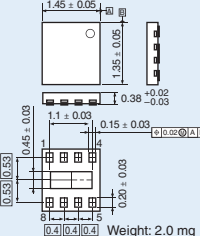
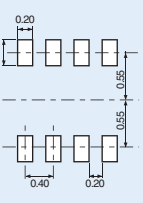
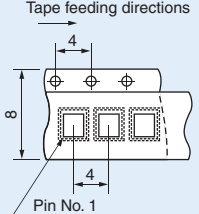
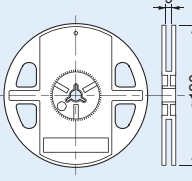
Note: For reference only. Be sure to verify device mountability.

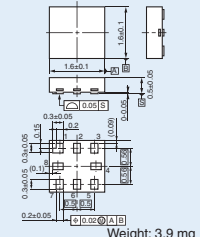
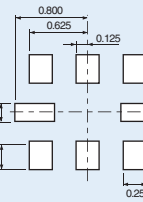
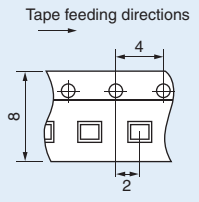
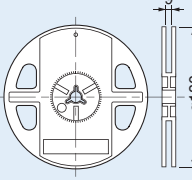
Toshiba Package Name	Package		Land Pattern Examples* Unit: mm	Standard Tape Packing Specifications		
	Appearance	Dimensions Unit: mm		Tape Type	Tape Dimensions Unit: mm	Reel Dimension Unit: mm
CST6C		 Weight: 2.0 mg		TE85L	 Tape feeding directions Pin No. 1	
Packing quantity 10000/reel						
CST6D		 Weight: 1.0 mg		TE85L		
Packing quantity 10000/reel						
CST6F		 Weight: 2.0 mg		TPL3		
Packing quantity 10000/reel						
ES6 (SOT-563) (SC-107C)		 Weight: 3.0 mg		TE85L	 Tape feeding directions Pin No. 1	
Packing quantity 4000/reel						
UDFN6 (2 in 1)		 Weight: 8.5 mg		TE85L	 Tape feeding directions	
Packing quantity 3000/reel						
UDFN6B (1 in 1)		 Weight: 8.5 mg		TE85L	 Tape feeding directions	
Packing quantity 3000/reel						
UF6		 Weight: 7.0 mg		TE85L	 Tape feeding directions Pin No. 1	
Packing quantity 3000/reel						

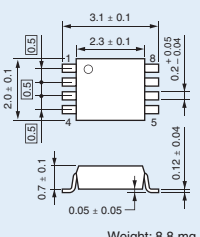
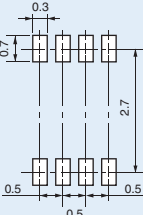
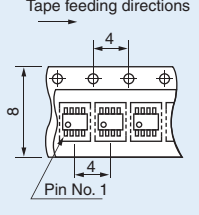
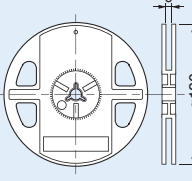
Note: For reference only. Be sure to verify device mountability.

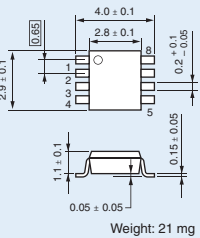
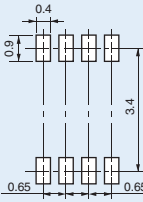
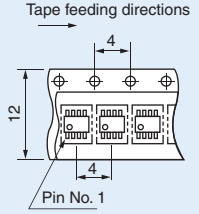
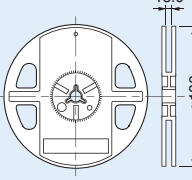
12 Packaging Information

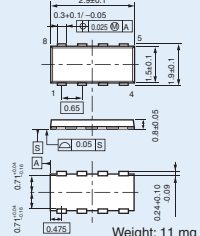
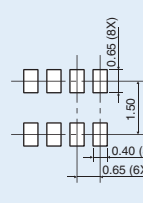
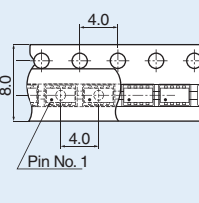
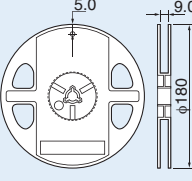
Toshiba Package Name	Package		Land Pattern Examples* Unit: mm	Standard Tape Packing Specifications		
	Appearance	Dimensions Unit: mm		Tape Type	Tape Dimensions Unit: mm	Reel Dimension Unit: mm
US6 (SOT-363) (SC-88)		 Weight: 6.8 mg		TE85L	 Pin No. 1	
Packing quantity 3000/reel						
SM6 (SOT-26) (SC-74)		 Weight: 15 mg		TE85L	 Pin No. 1	
Packing quantity 3000/reel						
CST8		 Weight: 2.0 mg		TE85L	 Pin No. 1	
Packing quantity 5000/reel						
MP8 (SOT-902)		 Weight: 3.9 mg		TE85L	 Pin No. 1	
Packing quantity 5000/reel						
US8 (SOT-765)		 Weight: 8.8 mg		TE85L	 Pin No. 1	
Packing quantity 3000/reel						
SM8 (SOT-505)		 Weight: 21 mg		TE12L	 Pin No. 1	
Packing quantity 3000/reel						
VS-8		 Weight: 11 mg		TE85L	 Pin No. 1	
Packing quantity 3000/reel						

Note: For reference only. Be sure to verify device mountability.

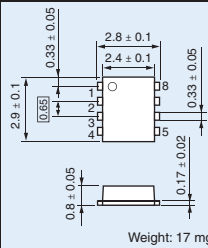
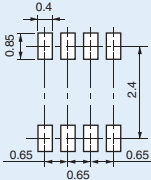
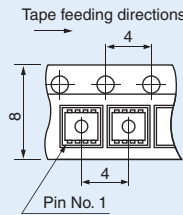
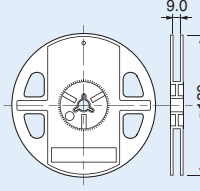
Toshiba Package Name	Package		Land Pattern Examples* Unit: mm	Standard Tape Packing Specifications		
	Appearance	Dimensions Unit: mm		Tape Type	Tape Dimensions Unit: mm	Reel Dimension Unit: mm
PS8		 Weight: 17 mg		TE85L	 Pin No. 1	
Packing quantity 3000/reel						

Note: For reference only. Be sure to verify device mountability.

13 Board Assembly

Soldering Temperature Profile

Perform soldering following the methods and conditions described in the respective technical datasheets and databooks for the device used. The soldering method, temperature and time may be restricted, depending on the device. All soldering temperature profiles and conditions described in the mounting methods below are representative. The profiles and conditions vary from product to product. Therefore, mount the product after first confirming the information described in the respective technical datasheets and databooks with the customer.

Reflow soldering and flow soldering must not be combined when performed. For details regarding special soldering including lead(Pb) soldering, please contact your nearest Toshiba office or distributor.

Using Infrared Reflow

1. It is recommended the top and bottom heating method with long or medium infrared rays.
2. Complete the infrared ray reflow process with a maximum package surface temperature of 260°C, within 30 to 50 seconds when a package surface temperature is 230°C or higher.
3. Refer to Figure 1 for an example of a temperature profile.

This profile is based on the device's maximum heat resistance guaranteed value. Set the preheat temperature/heating temperature to the optimum temperature corresponding to the solder paste type used by the customer within the above-described profile.

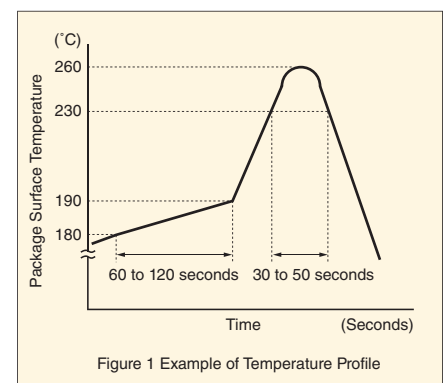

Using Hot Air Reflow

1. Complete hot air reflow with a maximum package surface temperature of 260°C, within 30 to 50 seconds when a package surface temperature is 230°C or higher.
2. For an example of a temperature profile, refer to Figure 1 above.

Using Solder Flow/Dip

1. Apply preheating for 60 to 120 seconds at a temperature of 150°C.
2. Mount the device within 10 seconds of solder flow with a maximum temperature of 260°C.
3. For insertion-type packages, mount the device at the stopper or at a location more than 1.5 mm from the body.
4. Surface-mount packages are greatly affected by thermal stress compared with the insertion-type packages; therefore, mount the device lower temperature and shorter mounting time than the condition listed in the above 2. to avoid thermal stress.

14 Part Naming Conventions

Part Naming Conventions

Small-Signal and Semi-Power MOSFET (SSM) Series

SSM 3 K 101 TU

(1) (2) (3) (4) (5)

(1) Small-signal MOSFET	(4) Serial number of the products
(2) Pin count	(5) Package
(3) Polarity and internal configuration	<3-pin> <4-pin> <6-pin>
K: N-channel, single	F: S-Mini CT: CST4 FU: US6
J: P-channel, single	FU: USM FE: ES6
N: N-channel, dual	FS: SSM <5-pin> TU: UF6
P: P-channel, dual	FV: VESM F: SMV CTD: CST6D
L: N-channel and P-channel (dual)	T: TSM FU: USV NU: UDFN6
E: N-channel and P-channel (pre-wired as a load switch)	TU: UFM FE: ESV
H: N-channel and SBD	CT: CST3 TU: UFV
G: P-channel and SBD	CTB: CST3B R: SOT-23F

Power MOSFET Series

TPC8 0 01 -H

(1) (2) (3) (4)

(1) TPC6: VS-6 Series	(2) 0: N-channel, single
TPCF8: VS-8 Series	1: P-channel, single
TPCP8: PS-8 Series	2: N-channel, dual
TPCC8: TSON Advance Series	3: P-channel, dual
TPC8: SOP-8 Series	4: N-channel and P-channel, dual
TPCA8: SOP Advance Series	A: N-channel and SBD
TPCL4: Chip LGA	B: P-channel and SBD
	J: P-channel and NPN
	(3) Serial number of the products
	(4) -H: High-speed type
	Blank: Low-ON-resistance type

LDO (Low-Dropout Regulators)

TCR 4 S 18 D WBG

(1) (2) (3) (4) (5) (6)

(1) Toshiba CMOS LDO regulator
(2) Pin count
(3) Single output
(4) Output voltage
Examples: 18: 1.8 V, 285: 2.85 V
(5) D: Auto-discharge and pull-down resistor on CE
Blank: No auto-discharge and no pull resistor on CE
(6) WBG: WCSP4
FE: ESV
U: UFV, UF6
Blank/A: SMV, SM6

L-MOS

TC 7 S H U 04 FU

(1) (2) (3) (4) (5) (6) (7) (8)

(1) Toshiba CMOS device	(6) Function
(2), (4) Product series	Same as for standard CMOS logic
4__: Standard Series	(7) Letter beginning with A
7__: High-Speed Series	for upgraded versions
7__H: VHS Series	(8) Package type
7__E: VHS TTL-Level Input Series	F: SMV
7__Z: SHS Series	FU: SM8, USV or US6
7__A: AHS Series	FK: US8
7__G: LVP Series	FE: ESV or ES6
(3) Number of Pins	FC: CST8
S: 5 pins	FS: fSV
P: 6 pins	L8X: MP8
W: 8 pins	
(5) U: Unbuffered	
T: TTL-level inputs	
Blank: Buffered	

■ Magnetic Sensors

TCS 10 S P U
 (1) (2) (3) (4) (5)

- | | |
|---|--------------------------|
| (1) Toshiba CMOS magnetic sensor | (4) Output configuration |
| (2) Type | P: Push-pull output |
| 10: High-sensitivity type | L: Open-drain output |
| 11: High-sensitivity type with inverting output | (5) Package type |
| 20: Standard type | U: UFV (SC-88A-like) |
| (3) Polarity | R: SOT-23F (SOT23-like) |
| S: Unipolar, south pole | C: CST6C |
| N: Unipolar, north pole | |
| D: Bipolar | |

■ ESD-Protection Diodes

DF 5 A 6.2 L FU
 (1) (2) (3) (4) (5) (6)

- (1) Toshiba ESD-protection diode
 (2) Package pin count
 Note: The digit 7 denotes a 6-pin package.
 (3) Internal configuration
 Example: A: Common anode
 (4) Clamp voltage (V_{BR})
 (5) Series
 Example: L: Ultra-high-speed
 (6) Package style

■ Schottky Barrier Diodes (New Naming Conventions)

CU S 05 F 30 A
 (1) (2) (3) (4) (5) (6)

- (1) Package
 Examples: CE: ESC, CU: USC, CB: CST2B
 (2) Pin count
 Example: S: 2-pin
 (3) Current rating
 Example: 07: 0.7 A
 (4) Device type
 Examples: F: Low-voltage, R: Low-leakage
 (5) Voltage rating
 Example: 30: 30 V
 (6) Revision or functional category (A to Z)

■ Schottky Barrier Diodes (Old Naming Conventions)

DS F 07 S 30 A U
 (1) (2) (3) (4) (5) (6) (7)

- (1) DS stands for Toshiba Schottky barrier diode.
 (2) Device feature
 This letter shows the feature of a device.
 R: Low leakage current type.
 F: Low forward voltage type.
 (3) Current rating
 Examples: 07: 0.7 A, 10: 1 A
 (4) Circuit configuration and number of pins
 (5) Voltage rating
 Examples: 30: 30 V, 15: 15 V
 (6) Revision
 The additional symbol for upgraded versions
 (7) Package style
 This letter shows the package style.

■ Transistor with Built-In Resistance (BRT)

RN 2 1 07 MFV
 (1) (2) (3) (4) (5)

- (1) RN means Toshiba transistor that has a built-in resistance
 (2) Polarity
 This number shows the polarity of a product.
 Products are classified into three types, as shown below, by the polarity.
 1: NPN (small-signal)
 2: PNP (small-signal)
 4: PNP+NPN
 (3), (5) Package type
 (4) Serial number
 Serial numbers that start from "A1": Dual
 Serial numbers that start from "01": Single

■ Operational Amplifiers and Comparators

TC 75 S 63 TU
 (1) (2) (3) (4) (5)

- | | |
|--|--|
| (1) Circuit type | (4) Serial number |
| TA: Bipolar type | Second source products use the same have their own number. |
| TC: CMOS type | Numbers as for original products. |
| (2) The number here indicates operational amplifiers and comparators | (5) Package type |
| (3) Number of circuits | F: SMV |
| S: Single circuit | FU: USV |
| W: Dual | FE: ESV |
| | FU: SM8 |
| | FK: US8 |
| | TU: UFV |

Toshiba America**Electronic Components, Inc.**

- Irvine, Headquarters
Tel: (949)623-2900 Fax: (949)474-1330
- Buffalo Grove (Chicago)
Tel: (847)484-2400 Fax: (847)541-7287
- Duluth/Atlanta
Tel: (770)931-3363 Fax: (770)931-7602
- El Paso
Tel: (915)771-8156
- Marlborough
Tel: (508)481-0034 Fax: (508)481-8828
- Parsippany
Tel: (248)347-2607 Fax: (973)541-4716
- San Jose
Tel: (408)526-2400 Fax: (408)526-2410
- Wixom (Detroit)
Tel: (248)347-2607 Fax: (248)347-2602
- Bloomington
Tel: (952)842-2400 Fax: (952)893-8031
- San Diego
Tel: (858)385-5900 Fax: (858)674-7606

Toshiba Electronics do Brasil Ltda.

Tel: (011)2539-6681 Fax: (011)2539-6675

Toshiba Electronics Europe GmbH

- Düsseldorf Head Office
Tel: (0211)5296-0 Fax: (0211)5296-400
- France Branch
Tel: (1)47282181
- Italy Branch
Tel: (039)68701 Fax: (039)6870205
- Spain Branch
Tel: (91)660-6798 Fax: (91)660-6799
- U.K. Branch
Tel: (0870)060-2370 Fax: (01252)53-0250
- Sweden Branch
Tel: (08)704-0900 Fax: (08)80-8459

Toshiba Electronics Asia (Singapore) Pte. Ltd.

Tel: (6278)5252 Fax: (6271)5155

Toshiba Electronics Service (Thailand) Co., Ltd.

Tel: (02)501-1635 Fax: (02)501-1638

Toshiba Electronics Trading (Malaysia) Sdn. Bhd.

- Kuala Lumpur Head Office
Tel: (03)5631-6311 Fax: (03)5631-6307
- Penang Office
Tel: (04)226-8523 Fax: (04)226-8515

Toshiba India Private Ltd.

Tel: (0124)499-6600 Fax: (0124)499-6611

Toshiba Electronics Asia, Ltd.

- Hong Kong Head Office
Tel: 2375-6111 Fax: 2375-0969
- Beijing Office
Tel: (010)6590-8796 Fax: (010)6590-8791
- Chengdu Office
Tel: (028)8675-1773 Fax: (028)8675-1065
- Qingdao Office
Tel: (532)8579-3328 Fax: (532)8579-3329

Toshiba Electronics (Shenzhen) Co., Ltd

Tel: (0755)2399-6897 Fax: (0755)2399-5573

Toshiba Electronics (Shanghai) Co., Ltd.

- Shanghai PUXI Branch
Tel: (021)6139-3888 Fax: (021)6190-8288

- Hangzhou Office
Tel: (0571)8717-5004 Fax: (0571)8717-5013

- Nanjing Office
Tel: (025)8689-0070 Fax: (025)8689-0070

Toshiba Electronics (Dalian) Co., Ltd.

Tel: (0411)8368-6882 Fax: (0411)8369-0822

Tsurong Xiamen Xiangyu Trading Co., Ltd.

Tel: (0592)226-1398 Fax: (0592)226-1399

Toshiba Electronics Korea Corporation

- Seoul Head Office
Tel: (02)3484-4334 Fax: (02)3484-4302
- Daegu Office
Tel: (053)428-7610 Fax: (053)428-7617

Toshiba Electronics Taiwan Corporation

- Taipei Head Office
Tel: (02)2508-9988 Fax: (02)2508-9999

- ▶ Toshiba Corporation, and its subsidiaries and affiliates (collectively "TOSHIBA"), reserve the right to make changes to the information in this document, and related hardware, software and systems (collectively "Product") without notice.
- ▶ This document and any information herein may not be reproduced without prior written permission from TOSHIBA. Even with TOSHIBA's written permission, reproduction is permissible only if reproduction is without alteration/omission.
- ▶ Though TOSHIBA works continually to improve Product's quality and reliability, Product can malfunction or fail. Customers are responsible for complying with safety standards and for providing adequate designs and safeguards for their hardware, software and systems which minimize risk and avoid situations in which a malfunction or failure of Product could cause loss of human life, bodily injury or damage to property, including data loss or corruption. Before customers use the Product, create designs including the Product, or incorporate the Product into their own applications, customers must also refer to and comply with (a) the latest versions of all relevant TOSHIBA information, including without limitation, this document, the specifications, the data sheets and application notes for Product and the precautions and conditions set forth in the "TOSHIBA Semiconductor Reliability Handbook" and (b) the instructions for the application with which the Product will be used with or for. Customers are solely responsible for all aspects of their own product design or applications, including but not limited to (a) determining the appropriateness of the use of this Product in such design or applications; (b) evaluating and determining the applicability of any information contained in this document, or in charts, diagrams, programs, algorithms, sample application circuits, or any other referenced documents; and (c) validating all operating parameters for such designs and applications. **TOSHIBA ASSUMES NO LIABILITY FOR CUSTOMERS' PRODUCT DESIGN OR APPLICATIONS.**
- ▶ Product is intended for use in general electronics applications (e.g., computers, personal equipment, office equipment, measuring equipment, industrial robots and home electronics appliances) or for specific applications as expressly stated in this document. Product is neither intended nor warranted for use in equipment or systems that require extraordinarily high levels of quality and/or reliability and/or a malfunction or failure of which may cause loss of human life, bodily injury, serious property damage or serious public impact ("Unintended Use"). Unintended Use includes, without limitation, equipment used in nuclear facilities, equipment used in the aerospace industry, medical equipment, equipment used for automobiles, trains, ships and other transportation, traffic signaling equipment, equipment used to control combustions or explosions, safety devices, elevators and escalators, devices related to electric power, and equipment used in finance-related fields. Do not use Product for Unintended Use unless specifically permitted in this document.
- ▶ Do not disassemble, analyze, reverse-engineer, alter, modify, translate or copy Product, whether in whole or in part.
- ▶ Product shall not be used for or incorporated into any products or systems whose manufacture, use, or sale is prohibited under any applicable laws or regulations.
- ▶ The information contained herein is presented only as guidance for Product use. No responsibility is assumed by TOSHIBA for any infringement of patents or any other intellectual property rights of third parties that may result from the use of Product. No license to any intellectual property right is granted by this document, whether express or implied, by estoppel or otherwise.
- ▶ **ABSENT A WRITTEN SIGNED AGREEMENT, EXCEPT AS PROVIDED IN THE RELEVANT TERMS AND CONDITIONS OF SALE FOR PRODUCT, AND TO THE MAXIMUM EXTENT ALLOWABLE BY LAW, TOSHIBA (1) ASSUMES NO LIABILITY WHATSOEVER, INCLUDING WITHOUT LIMITATION, INDIRECT, CONSEQUENTIAL, SPECIAL, OR INCIDENTAL DAMAGES OR LOSS, INCLUDING WITHOUT LIMITATION, LOSS OF PROFITS, LOSS OF OPPORTUNITIES, BUSINESS INTERRUPTION AND LOSS OF DATA, AND (2) DISCLAIMS ANY AND ALL EXPRESS OR IMPLIED WARRANTIES AND CONDITIONS RELATED TO SALE, USE OF PRODUCT, OR INFORMATION, INCLUDING WARRANTIES OR CONDITIONS OF MERCHANTABILITY, FITNESS FOR A PARTICULAR PURPOSE, ACCURACY OF INFORMATION, OR NONINFRINGEMENT.**
- ▶ Do not use or otherwise make available Product or related software or technology for any military purposes, including without limitation, for the design, development, use, stockpiling or manufacturing of nuclear, chemical, or biological weapons or missile technology products (mass destruction weapons). Product and related software and technology may be controlled under the Japanese Foreign Exchange and Foreign Trade Law and the U.S. Export Administration Regulations. Export and re-export of Product or related software or technology are strictly prohibited except in compliance with all applicable export laws and regulations.
- ▶ Product may include products subject to foreign exchange and foreign trade control laws.
- ▶ Please contact your TOSHIBA sales representative for details as to environmental matters such as the RoHS compatibility of Product. Please use Product in compliance with all applicable laws and regulations that regulate the inclusion or use of controlled substances, including without limitation, the EU RoHS Directive. TOSHIBA assumes no liability for damages or losses occurring as a result of noncompliance with applicable laws and regulations.

Mouser Electronics

Authorized Distributor

Click to View Pricing, Inventory, Delivery & Lifecycle Information:

Toshiba:

[HN7G06FE-A\(TE85L,F](#)