

TC74HC221AFN

Dual Monostable Multivibrator

The TC74HC221A is a high speed CMOS MONOSTABLE MULTIVIBRATOR fabricated with silicon gate C²MOS technology.

It achieves the high speed operation similar to equivalent LSTTL while maintaining the CMOS low power dissipation.

There are two trigger inputs, \overline{A} input (negative edge), and B input (positive edge). These inputs are valid for a slow rise/fall time signal ($t_r = t_f = 1$ s) as they are schmitt trigger inputs. This device may also be triggered by using \overline{CLR} input (positive edge).

After triggering, the output stays in a MONOSTABLE state for a time period determined by the external resistor and capacitor (R_x, C_x). A low level at the \overline{CLR} input breaks this state.

Limits for C_x and R_x are:

External capacitor, C_x : No limit

External resistor, R_x : $V_{CC} = 2.0$ V more than 5 k Ω

$V_{CC} \geq 3.0$ V more than 1 k Ω

All inputs are equipped with protection circuits against static discharge or transient excess voltage.

Features (Note)

- High speed: $t_{pd} = 25$ ns (typ.) at $V_{CC} = 5$ V
- Low power dissipation
 - Standby by State: $I_{CC} = 4$ μ A (max) at $T_a = 25^\circ\text{C}$
 - Active State: $I_{CC} = 700$ μ A (max) at $T_a = 25^\circ\text{C}$
- High noise immunity: $V_{NIH} = V_{NIL} = 28\%$ V_{CC} (min)
- Output drive capability: 10 LSTTL loads
- Symmetrical output impedance: $|I_{OH}| = I_{OL} = 4$ mA (min)
- Balanced propagation delays: $t_{pLH} \approx t_{pHL}$
- Wide operating voltage range: $V_{CC}(\text{opr}) = 2$ to 6 V
- Pin and function compatible with 74LS221

Note: In the case of using only one circuit, \overline{CLR} should be tied to GND, $R_x/C_x \cdot C_x \cdot Q \cdot \overline{Q}$ should be tied to OPEN, the other inputs should be tied to V_{CC} or GND.

Note: xxxFN (JEDEC SOP) is not available in Japan.

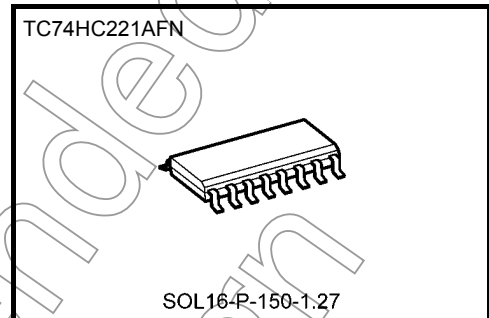

Weight
SOL16-P-150-1.27 : 0.13 g (typ.)

Pin Assignment

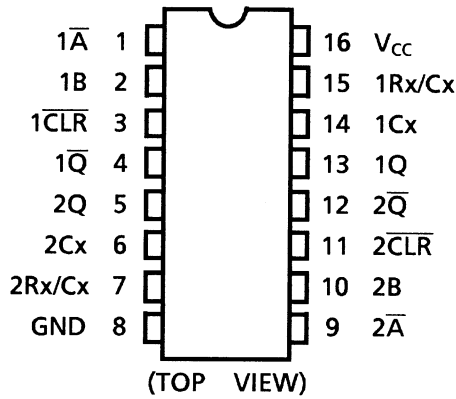

IEC Logic Symbol

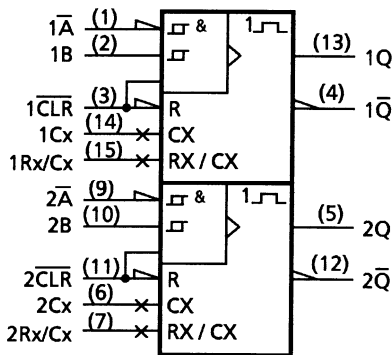

Block Diagram (Note 1)(Note 2)

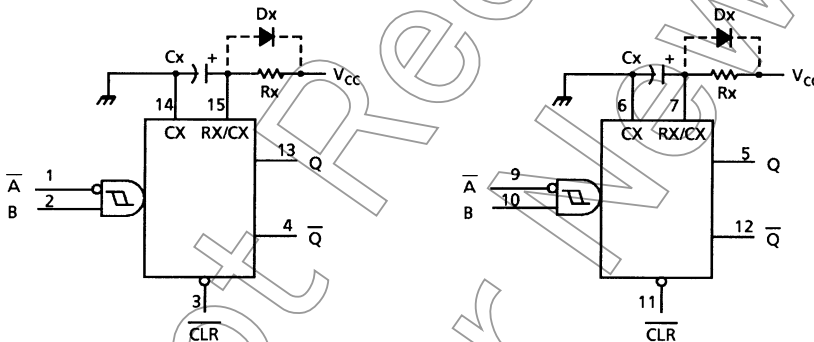

Note 1: Cx, Rx, Dx are external capacitor, resistor, and diode, respectively.

Note 2: External clamping diode, Dx;

The external capacitor is charged to V_{CC} level in the wait state, i.e. when no trigger is applied.

If the supply voltage is turned off, Cx is discharges mainly through the internal (parasitic) diode. If Cx is sufficiently large and V_{CC} drops rapidly, there will be some possibility of damaging the IC through in rush current or latch-up. If the capacitance of the supply voltage filter is large enough and V_{CC} drops slowly, the in rush current is automatically limited and damage to the IC is avoided.

The maximum value of forward current through the parasitic diode is ±20 mA.

In the case of a large Cx, the limit of fall time of the supply voltage is determined as follows:

$$t_f \geq (V_{CC} - 0.7) Cx / 20 \text{ mA}$$

(t_f is the time between the supply voltage turn off and the supply voltage reaching 0.4 V_{CC}.)

In the even a system does not satisfy the above condition, an external clamping diode (Dx) is needed to protect the IC from rush current.

Truth Table

Inputs			Outputs		Function
\bar{A}	B	\overline{CLR}	Q	\bar{Q}	
	H	H			Output Enable
X	L	H	L	H	Inhibit
H	X	H	L	H	Inhibit
L		H			Output Enable
L	H				Output Enable
X	X	L	L	H	Inhibit

X: Don't care

System Diagram

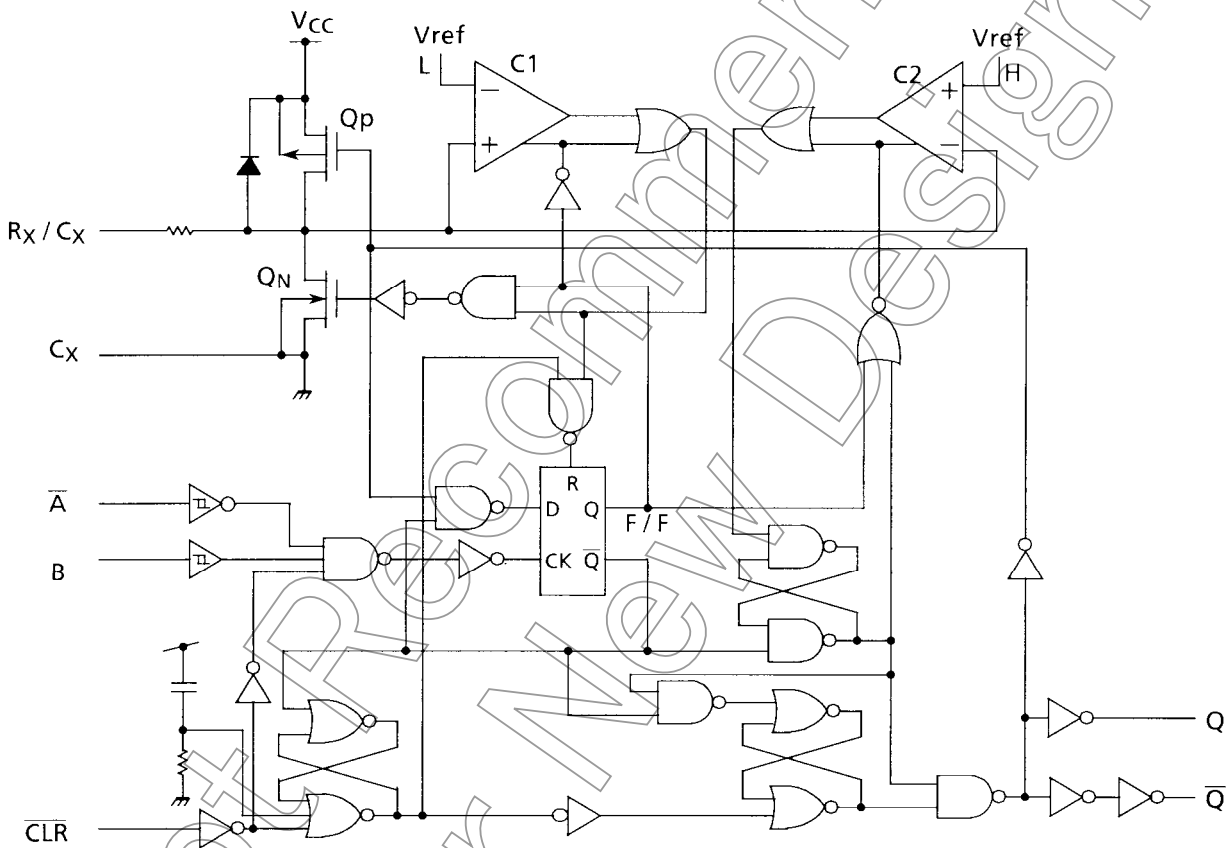

Timing Chart

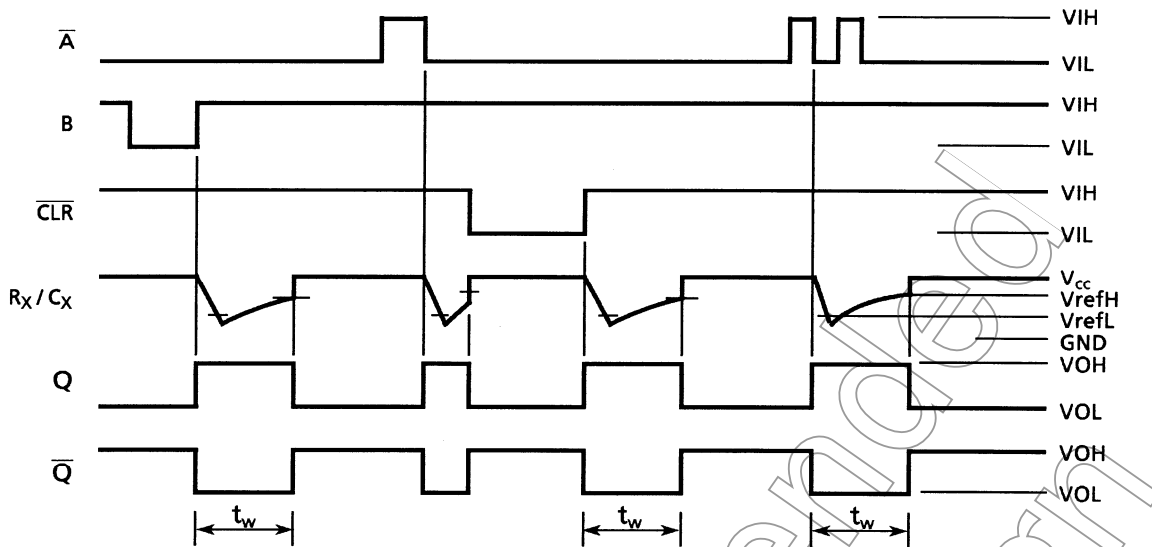

Functional Description

(1) Stand-by state

The external capacitor (C_x) is fully charged to V_{CC} in the stand-by state. That means, before triggering, the QP and QN transistors which are connected to the Rx/Cx node are in the off state. Two comparators that relate to the timing of the output pulse, and two reference voltage supplies turn off. The total supply current is only leakage current.

(2) Trigger operation

Trigger operation is effective in any of the following three cases. First the condition where the \bar{A} input is low, and the B input has a rising signal; second, where the B input is high, and the \bar{A} input has a falling signal; and third, where the \bar{A} input is low and the B input is high, and the \bar{CLR} input has a rising signal.

After a trigger becomes effective, comparators C1 and C2 start operating, and QN is turned on. The external capacitor discharges through QN. The voltage level at the Rx/Cx node drops. If the Rx/Cx voltage level falls to the internal reference voltage V_{refL} , the output of C1 becomes low. The flip-flop is then reset and QN turns off. At that moment C1 stops but C2 continues operating.

After QN turns off, the voltage at the Rx/Cx node starts rising at a rate determined by the time constant of external capacitor C_x and resistor R_x .

Upon the triggering, output Q becomes high, following some delay time of the internal F/F and gates. It stays high even if the voltage of Rx/Cx changes from falling to rising. When Rx/Cx reaches the internal reference voltage V_{refH} , the output of C2 becomes low, the output Q goes low and C2 stops its operation. That means, after triggering, when the voltage level of the Rx/Cx node reaches V_{refH} , the IC returns to its MONOSTABLE state.

With large values of C_x and R_x , and ignoring the discharge time of the capacitor and internal delays of the IC, the width of the output pulse, t_w (OUT), is as follows:

$$t_w \text{ (OUT)} = 1.0 C_x R_x$$

(3) Reset operation

In normal operation, \bar{CLR} input is held high. If \bar{CLR} is low, a trigger has no effect because the Q output is held low and trigger control F/F is reset. Also, QP turns on and C_x is charge rapidly to V_{CC} .

This means if \bar{CLR} input is set low, the IC goes into a wait state.

Absolute Maximum Ratings (Note)

Characteristics	Symbol	Rating	Unit
Supply voltage range	V_{CC}	-0.5 to 7	V
DC input voltage	V_{IN}	-0.5 to $V_{CC} + 0.5$	V
DC output voltage	V_{OUT}	-0.5 to $V_{CC} + 0.5$	V
Input diode current	I_{IK}	± 20	mA
Output diode current	I_{OK}	± 20	mA
DC output current	I_{OUT}	± 25	mA
DC V_{CC} /ground current	I_{CC}	± 50	mA
Power dissipation	P_D	180	mW
Storage temperature	T_{stg}	-65 to 150	$^{\circ}\text{C}$

Note: Exceeding any of the absolute maximum ratings, even briefly, lead to deterioration in IC performance or even destruction.

Using continuously under heavy loads (e.g. the application of high temperature/current/voltage and the significant change in temperature, etc.) may cause this product to decrease in the reliability significantly even if the operating conditions (i.e. operating temperature/current/voltage, etc.) are within the absolute maximum ratings and the operating ranges.

Please design the appropriate reliability upon reviewing the Toshiba Semiconductor Reliability Handbook ("Handling Precautions"/"Derating Concept and Methods") and individual reliability data (i.e. reliability test report and estimated failure rate, etc).

Operating Ranges (Note 1)

Characteristics	Symbol	Rating	Unit
Supply voltage	V_{CC}	2 to 6	V
Input voltage	V_{IN}	0 to V_{CC}	V
Output voltage	V_{OUT}	0 to V_{CC}	V
Operating temperature	T_{opr}	-40 to 85	$^{\circ}\text{C}$
Input rise and fall time ($\overline{\text{CLR}}$ only)	t_r, t_f	0 to 1000 ($V_{CC} = 2.0\text{ V}$) 0 to 500 ($V_{CC} = 4.5\text{ V}$) 0 to 400 ($V_{CC} = 6.0\text{ V}$)	ns
External capacitor	C_x	No limitation (Note 2)	F
External resistor	R_x	$\geq 5\text{ k}$ (Note 5) ($V_{CC} = 2.0\text{ V}$) $\geq 1\text{ k}$ (Note 5) ($V_{CC} \geq 3.0\text{ V}$)	Ω

Note 1: The operating ranges must be maintained to ensure the normal operation of the device.
Unused inputs must be tied to either VCC or GND.

Note 2: The maximum allowable values of C_x and R_x are a function of leakage of capacitor C_x , the leakage of TC74HC221A, and leakage due to board layout and surface resistance.

Susceptibility to externally induced noise signals may occur for $R_x > 1\text{ M}\Omega$.

Electrical Characteristics

DC Characteristics

Characteristics	Symbol	Test Condition	V _{CC} (V)	Ta = 25°C			Ta = -40 to 85°C		Unit	
				Min	Typ.	Max	Min	Max		
High-level input voltage	V _{IH}	—	2.0	1.50	—	—	1.50	—	V	
			4.5	3.15	—	—	3.15	—		
			6.0	4.20	—	—	4.20	—		
Low-level input voltage	V _{IL}	—	2.0	—	—	0.50	—	0.50	V	
			4.5	—	—	1.35	—	1.35		
			6.0	—	—	1.80	—	1.80		
High-level output voltage (Q, \bar{Q})	V _{OH}	V _{IN} = V _{IH} or V _{IL}	I _{OH} = -20 μ A	2.0	1.9	2.0	—	1.9	—	V
			I _{OH} = -4 mA	4.5	4.4	4.5	—	4.4	—	
			I _{OH} = -5.2 mA	6.0	5.9	6.0	—	5.9	—	
			I _{OH} = -5.2 mA	4.5	4.18	4.31	—	4.13	—	
Low-level output voltage (Q, \bar{Q})	V _{OL}	V _{IN} = V _{IH} or V _{IL}	I _{OL} = 20 μ A	2.0	—	0.0	0.1	—	0.1	V
			I _{OL} = 4 mA	4.5	—	0.0	0.1	—	0.1	
			I _{OL} = 5.2 mA	6.0	—	0.0	0.1	—	0.1	
			I _{OL} = 5.2 mA	4.5	—	0.17	0.26	—	0.33	
Input leakage current	I _{IN}	V _{IN} = V _{CC} or GND	6.0	—	—	\pm 0.1	—	\pm 1.0	μ A	
			4.5	—	—	\pm 0.1	—	\pm 1.0	μ A	
			2.0	—	—	\pm 0.1	—	\pm 1.0	μ A	
Rx/Cx terminal off-state current	I _{IN}	V _{IN} = V _{CC} or GND	6.0	—	—	\pm 0.1	—	\pm 1.0	μ A	
			4.5	—	—	\pm 0.1	—	\pm 1.0	μ A	
			2.0	—	—	\pm 0.1	—	\pm 1.0	μ A	
Quiescent supply current	I _{CC}	V _{IN} = V _{CC} or GND	6.0	—	—	4.0	—	40.0	μ A	
			4.5	—	—	4.0	—	40.0	μ A	
			2.0	—	—	4.0	—	40.0	μ A	
Active-state supply current (Note)	I _{CC}	V _{IN} = V _{CC} or GND Rx/Cx = 0.5 V _{CC}	2.0	—	45	200	—	260	μ A	
			4.5	—	400	500	—	650	μ A	
			6.0	—	0.7	1.0	—	1.3	mA	

Note: Per circuit

Timing Requirements (input: t_r = t_f = 6 ns)

Characteristics	Symbol	Test Condition	Ta = 25°C			Ta = -40 to 85°C	Unit
			V _{CC} (V)	Typ.	Limit	Limit	
Minimum pulse width	t _W (L) t _W (H)	—	2.0	—	75	95	ns
			4.5	—	15	19	
			6.0	—	13	16	
Minimum clear width	t _W (L)	—	2.0	—	75	95	ns
			4.5	—	15	19	
			6.0	—	13	16	

AC Characteristics ($C_L = 15 \text{ pF}$, $V_{CC} = 5 \text{ V}$, $T_a = 25^\circ\text{C}$, input: $t_r = t_f = 6 \text{ ns}$)

Characteristics	Symbol	Test Condition	Min	Typ.	Max	Unit
Output transition time	t_{TLH} t_{THL}	—	—	4	8	ns
Propagation delay time (\bar{A} , B-Q, \bar{Q})	t_{pLH} t_{pHL}	—	—	25	36	ns
Propagation delay time (\bar{CLR} TRIGGER-Q, \bar{Q})	t_{pLH} t_{pHL}	—	—	25	41	ns
Propagation delay time (\bar{CLR} -Q, \bar{Q})	t_{pLH} t_{pHL}	—	—	16	27	ns

Not Recommended
for New Design

AC Characteristics (C_L = 50 pF, input: t_r = t_f = 6 ns)

Characteristics	Symbol	Test Condition	V _{CC} (V)	Ta = 25°C			Ta = -40 to 85°C		Unit
				Min	Typ.	Max	Min	Max	
Output transition time	t _{TLH} t _{THL}	—	2.0	—	30	75	—	95	ns
			4.5	—	8	15	—	19	
			6.0	—	7	13	—	16	
Propagation delay time (\bar{A} , B-Q, \bar{Q})	t _{pLH} t _{pHL}	—	2.0	—	102	210	—	265	ns
			4.5	—	30	42	—	53	
			6.0	—	24	36	—	45	
Propagation delay time (\bar{CLR} TRIGGER-Q, Q)	t _{pLH} t _{pHL}	—	2.0	—	102	235	—	295	ns
			4.5	—	30	47	—	59	
			6.0	—	24	40	—	50	
Propagation delay time (\bar{CLR} -Q, \bar{Q})	t _{pLH} t _{pHL}	—	2.0	—	67	160	—	200	ns
			4.5	—	20	32	—	40	
			6.0	—	16	27	—	34	
Output pulse width	t _{wOUT}	Cx = 28 pF Rx = 6 kΩ (V _{CC} = 2 V) Rx = 2 kΩ (V _{CC} = 4.5 V, 6 V)	2.0	—	700	2000	—	2500	ns
			4.5	—	250	400	—	500	
			6.0	—	210	340	—	425	
		Cx = 0.01 μF Rx = 10 kΩ	2.0	90	110	130	90	130	μs
			4.5	95	105	115	95	115	
			6.0	95	105	115	95	115	
		Cx = 0.1 μF Rx = 10 kΩ	2.0	0.9	1.0	1.2	0.9	1.2	ms
			4.5	0.9	1.0	1.1	0.9	1.1	
			6.0	0.9	1.0	1.1	0.9	1.1	
Output pulse width error between circuits (in same package)	Δt _{wOUT}	—	—	±1	—	—	—	%	
Input capacitance	C _{IN}	—	—	5	10	—	10	pF	
Power dissipation capacitance	C _{PD} (Note)	—	—	174	—	—	—	pF	

Note: C_{PD} is defined as the value of the internal equivalent capacitance which is calculated from the operating current consumption without load.

Average operating current can be obtained by the equation:

$$I_{CC}(\text{opr}) = C_{PD} \cdot V_{CC} \cdot f_{IN} + I_{CC}' \cdot \text{duty}/100 + I_{CC}/2 \text{ (per circuit)}$$

(I_{CC}': active supply current)

(duty: %)

Output Pulse Width Constant K – Supply Voltage (typical)

(EXTERNAL RESISTOR (Rx) = 10kΩ : $t_{wOUT} = K \cdot Cx \cdot Rx$)

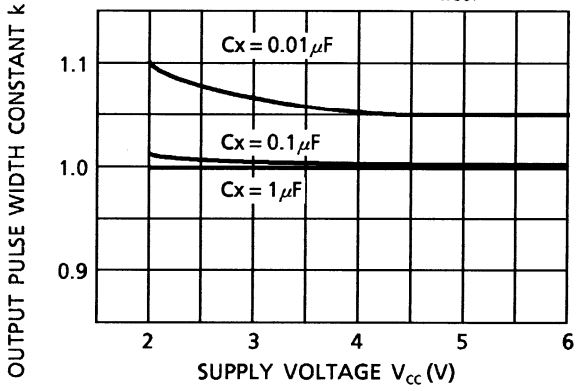

$t_{wOUT} - Cx$ Characteristics (typ.)

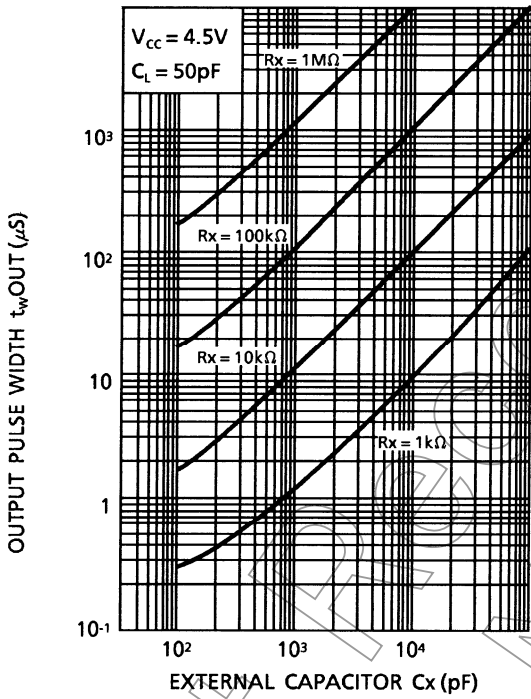

Package Dimensions (Note)

SOL16-P-150-1.27

Unit : mm

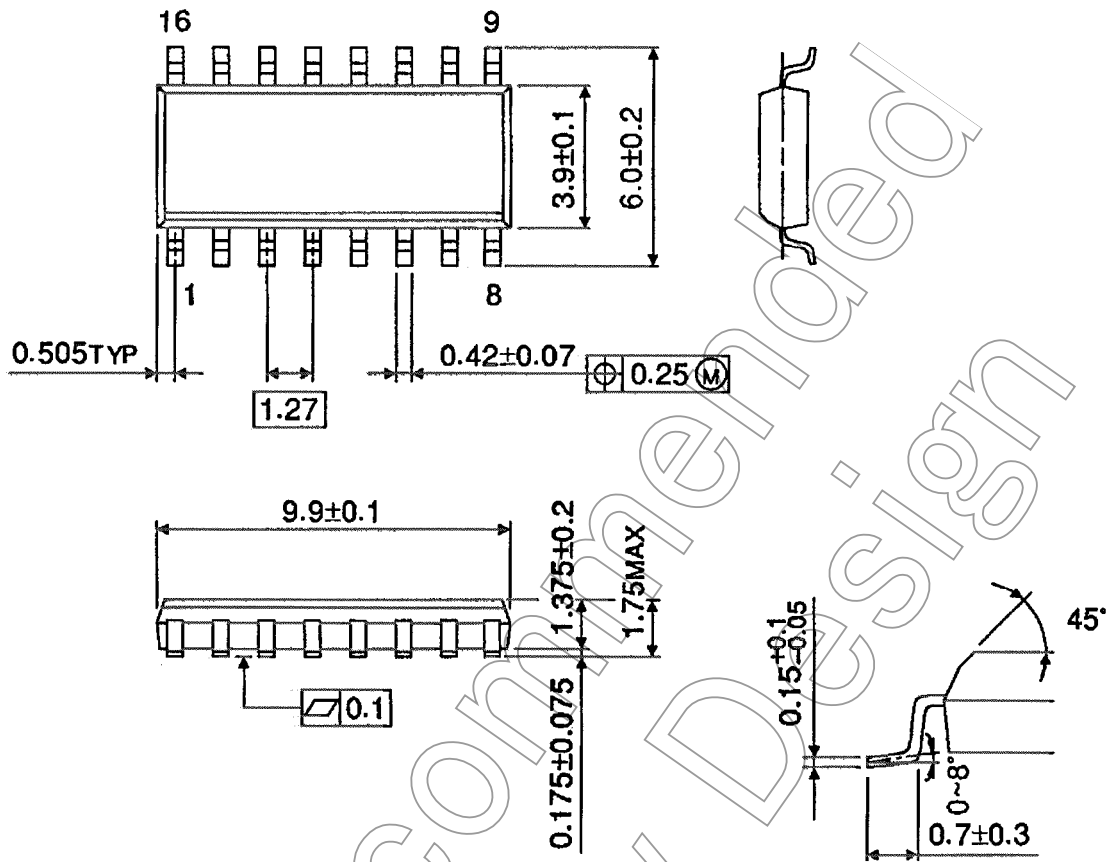

Note: This package is not available in Japan.

Weight: 0.13 g (typ.)

Not Recommended for New Design

RESTRICTIONS ON PRODUCT USE

- Toshiba Corporation, and its subsidiaries and affiliates (collectively "TOSHIBA"), reserve the right to make changes to the information in this document, and related hardware, software and systems (collectively "Product") without notice.
- This document and any information herein may not be reproduced without prior written permission from TOSHIBA. Even with TOSHIBA's written permission, reproduction is permissible only if reproduction is without alteration/omission.
- Though TOSHIBA works continually to improve Product's quality and reliability, Product can malfunction or fail. Customers are responsible for complying with safety standards and for providing adequate designs and safeguards for their hardware, software and systems which minimize risk and avoid situations in which a malfunction or failure of Product could cause loss of human life, bodily injury or damage to property, including data loss or corruption. Before customers use the Product, create designs including the Product, or incorporate the Product into their own applications, customers must also refer to and comply with (a) the latest versions of all relevant TOSHIBA information, including without limitation, this document, the specifications, the data sheets and application notes for Product and the precautions and conditions set forth in the "TOSHIBA Semiconductor Reliability Handbook" and (b) the instructions for the application with which the Product will be used with or for. Customers are solely responsible for all aspects of their own product design or applications, including but not limited to (a) determining the appropriateness of the use of this Product in such design or applications; (b) evaluating and determining the applicability of any information contained in this document, or in charts, diagrams, programs, algorithms, sample application circuits, or any other referenced documents; and (c) validating all operating parameters for such designs and applications. **TOSHIBA ASSUMES NO LIABILITY FOR CUSTOMERS' PRODUCT DESIGN OR APPLICATIONS.**
- **PRODUCT IS NEITHER INTENDED NOR WARRANTED FOR USE IN EQUIPMENTS OR SYSTEMS THAT REQUIRE EXTRAORDINARILY HIGH LEVELS OF QUALITY AND/OR RELIABILITY, AND/OR A MALFUNCTION OR FAILURE OF WHICH MAY CAUSE LOSS OF HUMAN LIFE, BODILY INJURY, SERIOUS PROPERTY DAMAGE AND/OR SERIOUS PUBLIC IMPACT ("UNINTENDED USE").** Except for specific applications as expressly stated in this document, Unintended Use includes, without limitation, equipment used in nuclear facilities, equipment used in the aerospace industry, medical equipment, equipment used for automobiles, trains, ships and other transportation, traffic signaling equipment, equipment used to control combustions or explosions, safety devices, elevators and escalators, devices related to electric power, and equipment used in finance-related fields. **IF YOU USE PRODUCT FOR UNINTENDED USE, TOSHIBA ASSUMES NO LIABILITY FOR PRODUCT.** For details, please contact your TOSHIBA sales representative.
- Do not disassemble, analyze, reverse-engineer, alter, modify, translate or copy Product, whether in whole or in part.
- Product shall not be used for or incorporated into any products or systems whose manufacture, use, or sale is prohibited under any applicable laws or regulations.
- The information contained herein is presented only as guidance for Product use. No responsibility is assumed by TOSHIBA for any infringement of patents or any other intellectual property rights of third parties that may result from the use of Product. No license to any intellectual property right is granted by this document, whether express or implied, by estoppel or otherwise.
- **ABSENT A WRITTEN SIGNED AGREEMENT, EXCEPT AS PROVIDED IN THE RELEVANT TERMS AND CONDITIONS OF SALE FOR PRODUCT, AND TO THE MAXIMUM EXTENT ALLOWABLE BY LAW, TOSHIBA (1) ASSUMES NO LIABILITY WHATSOEVER, INCLUDING WITHOUT LIMITATION, INDIRECT, CONSEQUENTIAL, SPECIAL, OR INCIDENTAL DAMAGES OR LOSS, INCLUDING WITHOUT LIMITATION, LOSS OF PROFITS, LOSS OF OPPORTUNITIES, BUSINESS INTERRUPTION AND LOSS OF DATA, AND (2) DISCLAIMS ANY AND ALL EXPRESS OR IMPLIED WARRANTIES AND CONDITIONS RELATED TO SALE, USE OF PRODUCT, OR INFORMATION, INCLUDING WARRANTIES OR CONDITIONS OF MERCHANTABILITY, FITNESS FOR A PARTICULAR PURPOSE, ACCURACY OF INFORMATION, OR NONINFRINGEMENT.**
- Do not use or otherwise make available Product or related software or technology for any military purposes, including without limitation, for the design, development, use, stockpiling or manufacturing of nuclear, chemical, or biological weapons or missile technology products (mass destruction weapons). Product and related software and technology may be controlled under the applicable export laws and regulations including, without limitation, the Japanese Foreign Exchange and Foreign Trade Law and the U.S. Export Administration Regulations. Export and re-export of Product or related software or technology are strictly prohibited except in compliance with all applicable export laws and regulations.
- Please contact your TOSHIBA sales representative for details as to environmental matters such as the RoHS compatibility of Product. Please use Product in compliance with all applicable laws and regulations that regulate the inclusion or use of controlled substances, including without limitation, the EU RoHS Directive. **TOSHIBA ASSUMES NO LIABILITY FOR DAMAGES OR LOSSES OCCURRING AS A RESULT OF NONCOMPLIANCE WITH APPLICABLE LAWS AND REGULATIONS.**