

Dual SPDT Analog Switch

DESCRIPTION

The DG9636 is a CMOS, dual SPDT analog switch designed to operate from 2.7 V to 12 V, single supply. All control logic inputs have a guaranteed 1.65 V logic HIGH threshold when operation from a 12 V power supply. This makes the DG9636 ideally suited to interface directly with low voltage micro-processor control signals.

Processed with high density CMOS technology, the DG9636 has a 83Ω channel ON resistance while providing ultra low parasitic capacitance of 2 pF for $C_{S(off)}$ and 7 pF for $C_{D(on)}$. Other performance features are: 720 MHz -3 dB bandwidth, -67 dB Cross Talk and -58 dB Off isolation at 10 MHz frequency.

Key applications for the DG9636 are logic level translation, pulse generator, and high speed or low noise signal switching in precision instrumentations and portable device designs.

The DG9636 is available in space saving 1.4 mm x 1.8 mm miniQFN10 package.

As a committed partner to the community and the environment, Vishay Siliconix manufactures this product with lead (Pb)-free device termination. The miniQFN-10 package has a nickel-palladium-gold device termination and is represented by the lead (Pb)-free “-E4” suffix to the ordering part number. The nickel-palladium-gold device terminations meet all JEDEC® standards for reflow and MSL rating.

FEATURES

- Leakage current < 0.5 nA max. at 85 °C
- Low switch capacitance ($C_{S(off)}$, 2 pF typ.)
- $R_{DS(on)}$ -83 Ω max.
- Low voltage, 1.65 V CMOS/TTL compatible
- 720 MHz, -3 dB bandwidth
- Fully specified with single supply operation at 12 V
- Excellent isolation and crosstalk performance (typ. > -60 dB at 10 MHz)
- Fully specified from -40 °C to 85 °C and -40 °C to +125 °C
- Latch-up current 300 mA per JESD78
- Lead (Pb)-free low profile miniQFN-10 (1.4 mm x 1.8 mm x 0.55 mm)
- Material categorization: For definitions of compliance please see www.vishay.com/doc?99912

RoHS
COMPLIANT

APPLICATIONS

- High-end data acquisition
- Medical instruments
- Precision instruments
- High speed communications applications
- Automated test equipment
- Sample and hold applications

FUNCTIONAL BLOCK DIAGRAM AND PIN CONFIGURATION

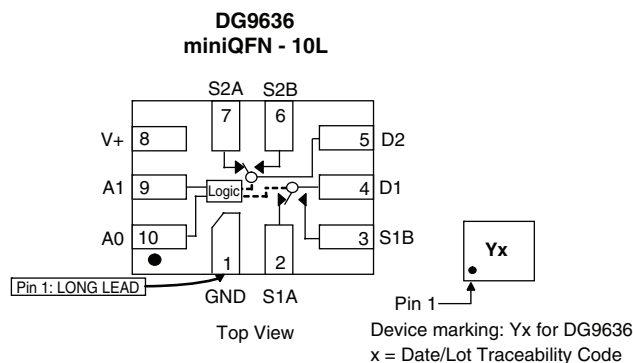

TRUTH TABLE		
Selected Input		On Switches
A1	A0	DG9636
X	0	D1 to S1A
X	1	D1 to S1B
0	X	D2 to S2A
1	X	D2 to S2B



ORDERING INFORMATION		
Temp. Range	Package	Part Number
-40 °C to 125 °C	10 pin miniQFN	DG9636EN-T1-E4
-40 °C to 85 °C	10 pin miniQFN	DG9636DN-T1-E4

Note

- 40 °C to 85 °C datasheet limits apply.

ABSOLUTE MAXIMUM RATINGS (T _A = 25 °C, unless otherwise noted)		
Parameter	Limit	Unit
V ₊ to GND	14	V
Digital Inputs ^a , V _S , V _D	(V ₊) +0.3 or 30 mA, whichever occurs first	
Continuous Current (Any Terminal)	30	mA
Peak Current, S or D (Pulsed 1 ms, 10 % Duty Cycle)	100	
Storage Temperature	-65 to 150	°C
Power Dissipation (Package) ^b	10 pin miniQFN ^{c, d}	208
Thermal Resistance (Package) ^b	10 pin miniQFN	357

Notes

- Signals on SX, DX, or AX exceeding V₊ or V₋ will be clamped by internal diodes. Limit forward diode current to maximum current ratings.
- All leads welded or soldered to PC board.
- Derate 2.6 mW/°C above 70 °C.
- Manual soldering with iron is not recommended for leadless components. The miniQFN-10 is a leadless package. The end of the lead terminal is exposed copper (not plated) as a result of the singulation process in manufacturing. A solder fillet at the exposed copper lip cannot be guaranteed and is not required to ensure adequate bottom side solder interconnection.

SPECIFICATIONS									
Parameter	Symbol	Test Conditions Unless Otherwise Specified V ₊ = 12 V, V _{A0, A1} = 1.65 V, 0.5 V ^a	Temp. ^b	Typ. ^c	-40 °C to 125 °C		-40 °C to 85 °C		Unit
					Min. ^d	Max. ^d	Min. ^d	Max. ^d	
Analog Switch									
Analog Signal Range ^e	V _{ANALOG}		Full	-	-	12	-	12	V
On-Resistance	R _{DS(on)}	I _S = 1 mA, V _D = +11.3 V	Room	83	-	110	-	110	Ω
			Full	-	-	140	-	125	
On-Resistance Match	ΔR _{on}	I _S = 1 mA, V _D = +11.3 V	Room	2	-	4	-	4	Ω
			Full	-	-	9	-	6	
On-Resistance Flatness	R _{FLATNESS}	I _S = 1 mA, V _D = 0.7 V, 6.5 V, 11.3 V	Room	33	-	45	-	45	Ω
			Full	-	-	55	-	50	
Switch Off Leakage Current	I _{S(off)}	V ₊ = 12 V, V _D = 1 V/11 V, V _S = 11 V/1 V	Room	± 0.01	-1	1	-1	1	nA
			Full	-	-18	18	-2	2	
	Room		± 0.01	-1	1	-1	1		
	Full		-	-18	18	-2	2		
Channel On Leakage Current	I _{D(on)}	V ₊ = 12 V, V _D = V _S 11 V/1 V	Room	± 0.01	-1	1	-1	1	
			Full	-	-18	18	-2	2	
Digital Control									
Input Current, V _{IN} Low	I _{IL}	V _{AX} = 0.5 V	Full	0.005	-0.1	0.1	-0.1	0.1	μA
Input Current, V _{IN} High	I _{IH}	V _{AX} = 1.65 V	Full	0.005	-0.1	0.1	-0.1	0.1	
Input Capacitance ^e	C _{IN}	f = 1 MHz	Room	3	-	-	-	-	pF



SPECIFICATIONS									
Parameter	Symbol	Test Conditions Unless Otherwise Specified $V_+ = 12\text{ V}, V_{A0, A1} = 1.65\text{ V}, 0.5\text{ V}^a$	Temp. ^b	Typ. ^c	-40 °C to 125 °C		-40 °C to 85 °C		Unit
					Min. ^d	Max. ^d	Min. ^d	Max. ^d	
Dynamic Characteristics									
Turn-On Time	t_{on}	$R_L = 300\ \Omega, C_L = 35\text{ pF}$ see figure 1, 2	Room	30	-	70	-	70	ns
			Full	-	-	90	-	80	
Turn-Off Time	t_{off}		Room	15	-	55	-	55	
			Full	-	-	75	-	65	
Break-Before-Make	t_{BBM}		Room	15	5	-	5	-	
			Full	-	2	-	2	-	
Charge Injection ^e	Q_{INJ}	$V_g = 0\text{ V}, R_g = 0\ \Omega, C_L = 1\text{ nF}$	Room	23.5	-	-	-	-	pC
Off Isolation ^e	OIRR	$R_L = 50\ \Omega, C_L = 5\text{ pF}, f = 10\text{ MHz}$	Room	-58	-	-	-	-	dB
Bandwidth ^e	BW	$R_L = 50\ \Omega$	Room	720	-	-	-	-	MHz
Channel-to-Channel Crosstalk ^e	X_{TALK}	$R_L = 50\ \Omega, C_L = 5\text{ pF}, f = 10\text{ MHz}$	Room	-67	-	-	-	-	dB
Dynamic Characteristics									
Source Off Capacitance ^e	$C_{S(off)}$	$f = 1\text{ MHz}$	Room	2	-	-	-	-	pF
Channel On Capacitance ^e	$C_{D(on)}$		Room	7.7	-	-	-	-	
Total Harmonic Distortion ^e	THD	Signal = 1 V_{RMS} , 20 Hz to 20 kHz, $R_L = 600\ \Omega$	Room	0.01	-	-	-	-	%
Power Supplies									
Power Supply Current	I_+	$V_{IN} = 0\text{ V}, \text{ or } V_+$	Room	0.001	-	0.5	-	0.5	μA
			Full	-	-	1	-	1	
Ground Current	I_{GND}		Room	-0.001	-0.5	-	-0.5	-	
			Full	-	-1	-	-1	-	

SPECIFICATIONS									
Parameter	Symbol	Test Conditions Unless Otherwise Specified $V_+ = 5\text{ V}, V_{A0, A1} = 1.4\text{ V}, 0.5\text{ V}^a$	Temp. ^b	Typ. ^c	-40 °C to 125 °C		-40 °C to 85 °C		Unit
					Min. ^d	Max. ^d	Min. ^d	Max. ^d	
Analog Switch									
Analog Signal Range ^e	V_{ANALOG}		Full	-	-	5	-	5	V
On-Resistance	$R_{DS(on)}$	$I_S = 1\text{ mA}, V_D = +3.5\text{ V}$	Room	120	-	170	-	170	Ω
			Full	-	-	250	-	200	
On-Resistance Match	ΔR_{on}		Room	3	-	5	-	5	
			Full	-	-	12	-	10	
Switch Off Leakage Current	$I_{S(off)}$	$V_+ = 5.5\text{ V},$ $V_D = 1\text{ V}/4.5\text{ V}, V_S = 4.5\text{ V}/1\text{ V}$	Room	± 0.01	-1	1	-1	1	nA
			Full	-	-18	18	-2	2	
	$I_{D(off)}$		Room	± 0.01	-1	1	-1	1	
			Full	-	-18	18	-2	2	
Channel On Leakage Current	$I_{D(on)}$	$V_+ = 5.5\text{ V}, V_S = V_D = 1\text{ V}/4.5\text{ V}$	Room	± 0.01	-1	1	-1	1	
			Full	-	-18	18	-2	2	
Digital Control									
Input Current, V_{IN} Low	I_L	$V_{AX} = 0.5\text{ V}$	Full	0.005	-0.1	0.1	-0.1	0.1	μA
Input Current, V_{IN} High	I_H	$V_{AX} = 1.4\text{ V}$	Full	0.005	-0.1	0.1	-0.1	0.1	
Input Capacitance	C_{IN}	$f = 1\text{ MHz}$	Room	3	-	-	-	-	pF



SPECIFICATIONS									
Parameter	Symbol	Test Conditions Unless Otherwise Specified $V_+ = 5\text{ V}$, $V_{A0,A1} = 1.4\text{ V}$, 0.5 V^a	Temp. ^b	Typ. ^c	-40 °C to 125 °C		-40 °C to 85 °C		Unit
					Min. ^d	Max. ^d	Min. ^d	Max. ^d	
Dynamic Characteristics									
Turn-On Time	t_{on}	$R_L = 300\ \Omega$, $C_L = 35\text{ pF}$ see figure 1, 2	Room	55	-	-	-	-	ns
			Full	-	-	-	-	-	
Turn-Off Time	t_{off}		Room	30	-	-	-	-	
			Full	-	-	-	-	-	
Break-Before-Make-Time	t_{BMM}		Room	36	-	-	-	-	
			Full	-	-	-	-	-	
Charge Injection ^e	Q_{INJ}	$C_L = 1\text{ nF}$, $R_{GEN} = 0\ \Omega$, $V_{GEN} = 0\text{ V}$	Full	10	-	-	-	-	pC
Off-Isolation ^e	OIRR	$f = 10\text{ MHz}$, $R_L = 50\ \Omega$, $C_L = 5\text{ pF}$	Room	-58	-	-	-	-	dB
Crosstalk ^e	X_{TALK}		Room	-68	-	-	-	-	
Bandwidth ^e	BW	$R_L = 50\ \Omega$	Room	610	-	-	-	-	MHz
Total Harmonic Distortion ^e	THD	Signal = 1 V_{RMS} , 20 Hz to 20 kHz, $R_L = 600\ \Omega$	Room	2.2	-	-	-	-	%
Source Off Capacitance ^e	$C_{S(off)}$	$f = 1\text{ MHz}$	Room	2.1	-	-	-	-	pF
Channel On Capacitance ^e	$C_{D(on)}$			8.1	-	-	-	-	
Power Supplies									
Power Supply Current	I_+	$V_{IN} = 0\text{ V}$, or V_+	Room	0.001	-	0.5	-	0.5	μA
			Full	-	-	1	-	1	
Ground Current	I_{GND}		Room	-0.001	-0.5	-	-0.5	-	
			Full	-	-1	-	-1	-	

SPECIFICATIONS									
Parameter	Symbol	Test Conditions Unless Otherwise Specified $V_+ = 3\text{ V}$, $V_{A0,A1} = 1.4\text{ V}$, 0.5 V^a	Temp. ^b	Typ. ^c	-40 °C to 125 °C		-40 °C to 85 °C		Unit
					Min. ^d	Max. ^d	Min. ^d	Max. ^d	
Analog Switch									
Analog Signal Range ^e	V_{ANALOG}		Full	-	-	3	-	3	V
On-Resistance	$R_{DS(on)}$	$I_S = 1\text{ mA}$, $V_D = +1.5\text{ V}$	Room	200	-	245	-	245	Ω
			Full	-	-	325	-	290	
On-Resistance Match	ΔR_{on}		Room	5	-	6	-	6	
			Full	-	-	13	-	11	
Switch Off Leakage Current (for 16 pin miniQFN)	$I_{S(off)}$	$V_+ = 3.3\text{ V}$, $V_- = 0\text{ V}$ $V_D = 1\text{ V}/3\text{ V}$, $V_S = 3\text{ V}/1\text{ V}$	Room	± 0.01	-1	1	-1	1	nA
			Full	-	-18	18	-2	2	
	Room		± 0.01	-1	1	-1	1		
	Full		-	-18	18	-2	2		
Channel On Leakage Current (for 16 pin miniQFN)	$I_{D(on)}$	$V_+ = 3.3\text{ V}$, $V_- = 0\text{ V}$, $V_S = V_D = 1\text{ V}/3\text{ V}$	Room	± 0.01	-1	1	-1	1	
			Full	-	-18	18	-2	2	
Digital Control									
Input Current, V_{IN} Low	I_L	$V_{AX} = 0.5\text{ V}$	Full	0.005	-0.1	0.1	-0.1	0.1	μA
Input Current, V_{IN} High	I_H	$V_{AX} = 1.4\text{ V}$	Full	0.005	-0.1	0.1	-0.1	0.1	
Input Capacitance	C_{IN}	$f = 1\text{ MHz}$	Room	3.1	-	-	-	-	pF



SPECIFICATIONS									
Parameter	Symbol	Test Conditions Unless Otherwise Specified $V_+ = 3\text{ V}$, $V_{A0, A1} = 1.4\text{ V}$, 0.5 V^a	Temp. ^b	Typ. ^c	-40 °C to 125 °C		-40 °C to 85 °C		Unit
					Min. ^d	Max. ^d	Min. ^d	Max. ^d	
Dynamic Characteristics									
Enable Turn-On Time	t_{on}	$R_L = 300\ \Omega$, $C_L = 35\text{ pF}$ see figure 1, 2	Room	96	-	-	-	-	ns
			Full	-	-	-	-	-	
Enable Turn-Off Time	t_{off}		Room	60	-	-	-	-	
			Full	-	-	-	-	-	
Break-Before-Make-Time	t_{BMM}		Room	77	-	-	-	-	
			Full	-	-	-	-	-	
Charge Injection ^e	Q_{INJ}	$C_L = 1\text{ nF}$, $R_{GEN} = 0\ \Omega$, $V_{GEN} = 0\text{ V}$	Full	6.6	-	-	-	-	pC
Off-Isolation ^e	OIRR	$f = 10\text{ MHz}$, $R_L = 50\ \Omega$, $C_L = 5\text{ pF}$	Room	-57	-	-	-	-	dB
Crosstalk ^e	X_{TALK}		Room	-69	-	-	-	-	
Bandwidth ^e	BW	$R_L = 50\ \Omega$	Room	525	-	-	-	-	MHz
Total Harmonic Distortion ^e	THD	Signal = 1 V_{RMS} , 20 Hz to 20 kHz, $R_L = 600\ \Omega$	Room	2.2	-	-	-	-	%
Source Off Capacitance ^e	$C_{S(off)}$	$f = 1\text{ MHz}$	Room	2.1	-	-	-	-	pF
Channel On Capacitance ^e	$C_{D(on)}$		Room	8.3	-	-	-	-	
Power Supplies									
Power Supply Current	I_+	$V_{IN} = 0\text{ V}$, or V_+	Room	0.001	-	0.5	-	0.5	μA
			Full	-	-	1	-	1	
Ground Current	I_{GND}		Room	-0.001	-0.5	-	-0.5	-	
			Full	-	-1	-	-1	-	

Notes

- a. V_{IN} = input voltage to perform proper function.
- b. Room = 25 °C, Full = as determined by the operating temperature.
- c. Typical value are for DESIGN AID ONLY, not guaranteed nor subject to production testing.
- d. The algebraic convention whereby the most negative value is a minimum and the most positive a maximum, is used in this datasheet.
- e. Guaranteed by design, not subject to production test.

Stresses beyond those listed under "Absolute Maximum Ratings" may cause permanent damage to the device. These are stress ratings only, and functional operation of the device at these or any other conditions beyond those indicated in the operational sections of the specifications is not implied. Exposure to absolute maximum rating conditions for extended periods may affect device reliability.

TYPICAL CHARACTERISTICS (25 °C, unless otherwise noted)

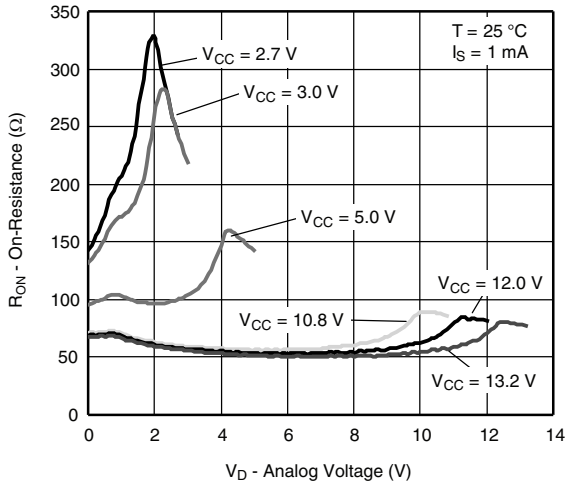

On-Resistance vs. Single Supply Voltage

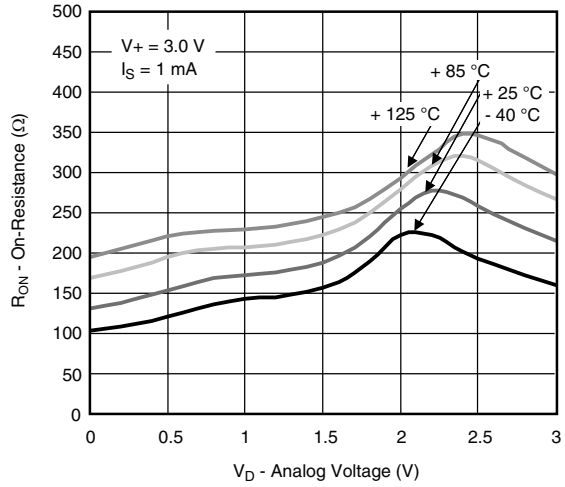

On-Resistance vs. Analog Voltage and Temperature

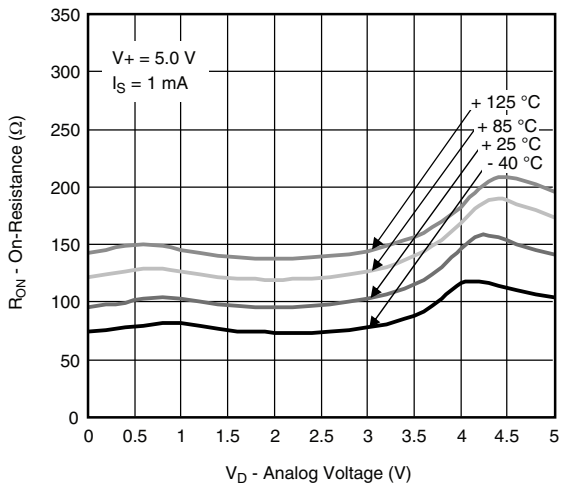

On-Resistance vs. Analog Voltage and Temperature

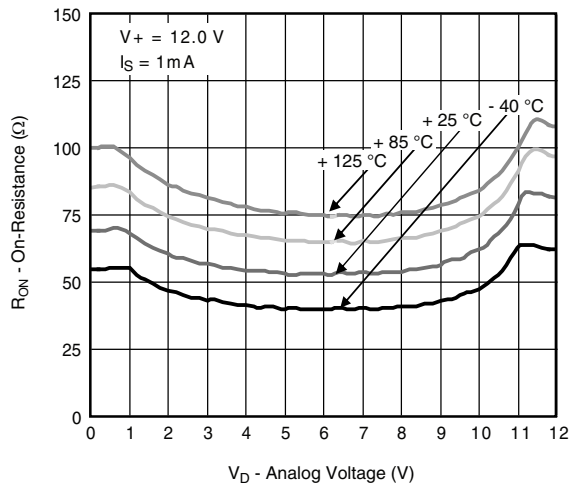

On-Resistance vs. Analog Voltage and Temperature

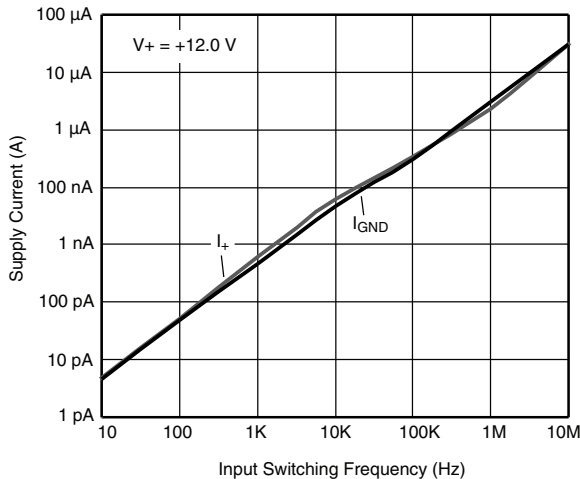

Supply Current vs. Input Switching Frequency

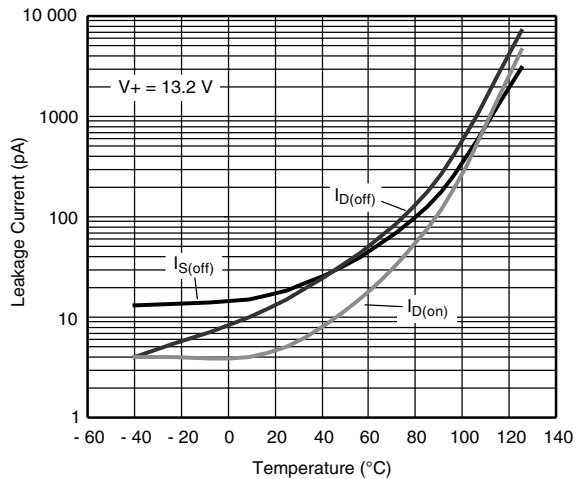

Leakage Current vs. Temperature

TYPICAL CHARACTERISTICS (25 °C, unless otherwise noted)

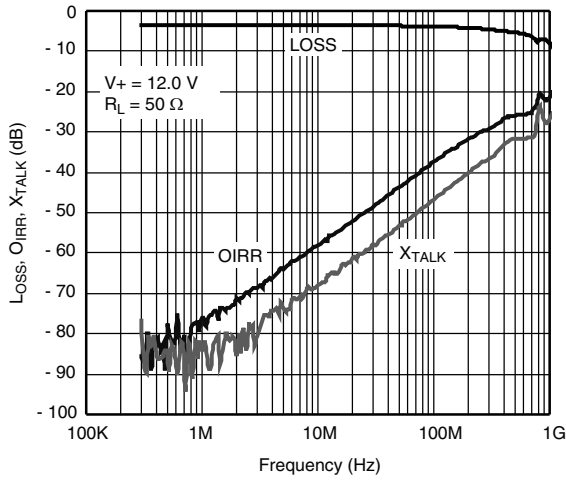

Insertion Loss, Off-Isolation, Crosstalk vs. Frequency

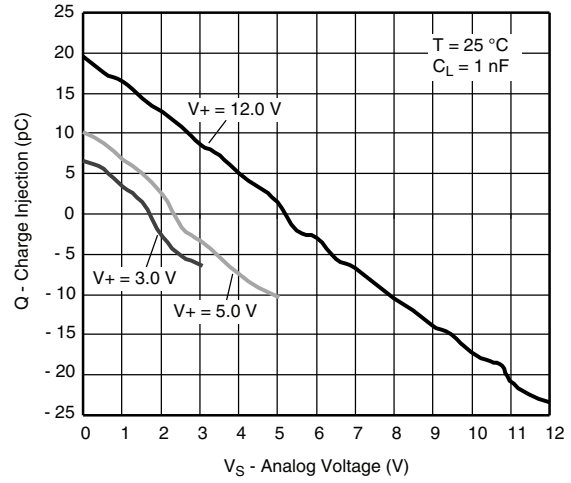

Charge Injection vs. Analog voltage

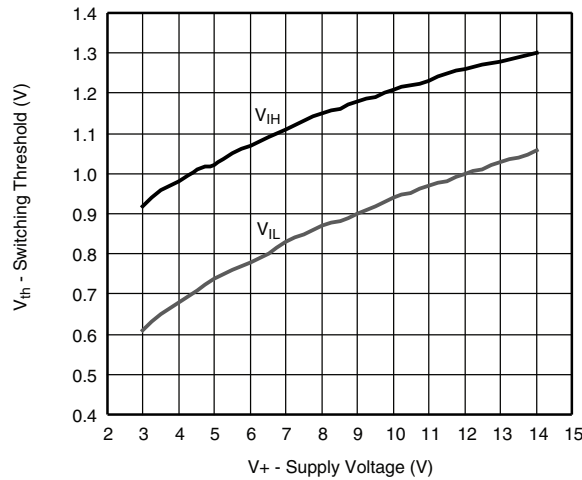

Switching Threshold vs. Supply Voltage

TEST CIRCUITS

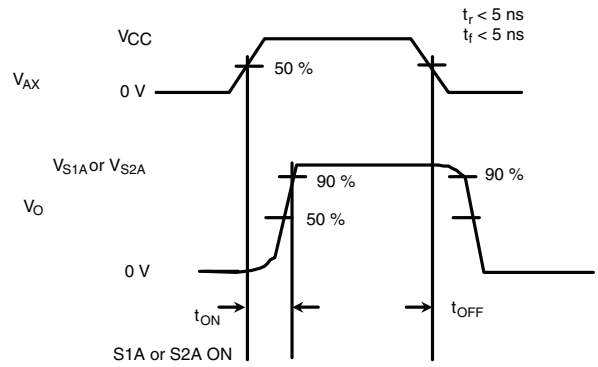
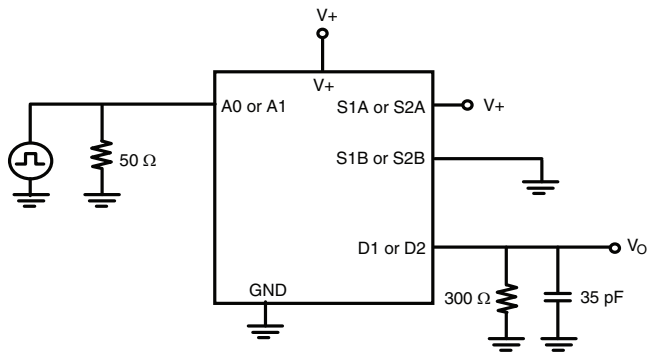

Figure 1. Enable Switching Time

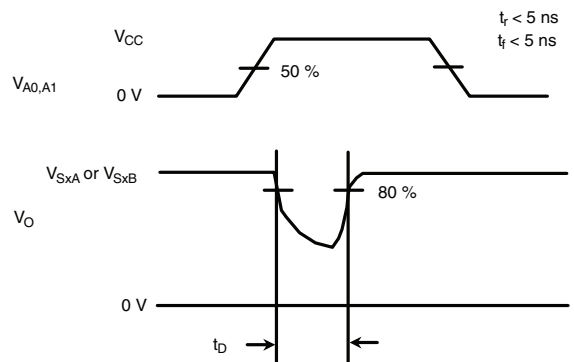
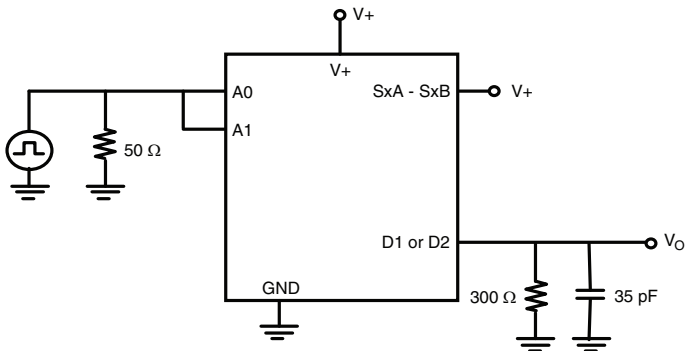

Figure 2. Break-Before-Make

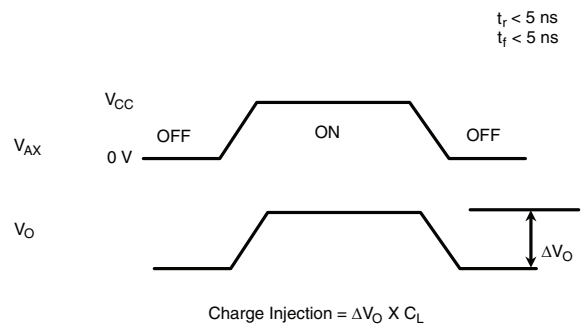
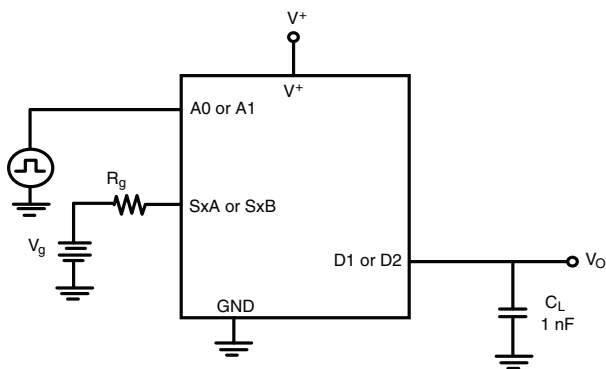

Figure 3. Charge Injection

TEST CIRCUITS

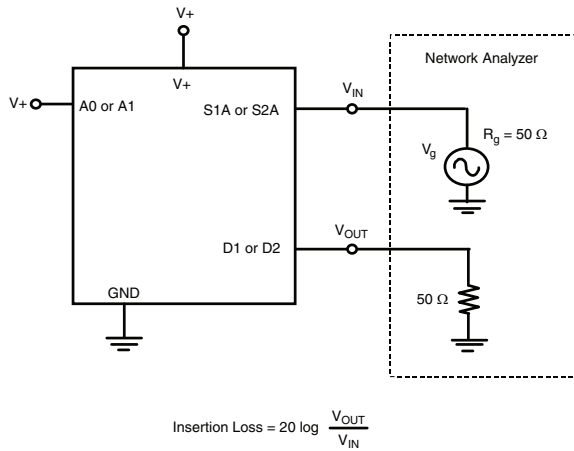

Figure 4. Insertion Loss

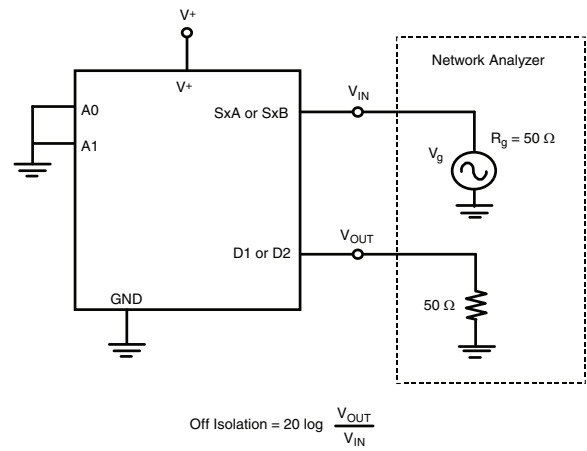

Figure 5. Off-Isolation

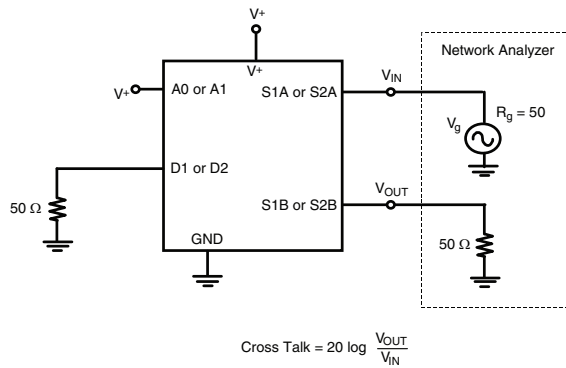

Figure 6. Crosstalk

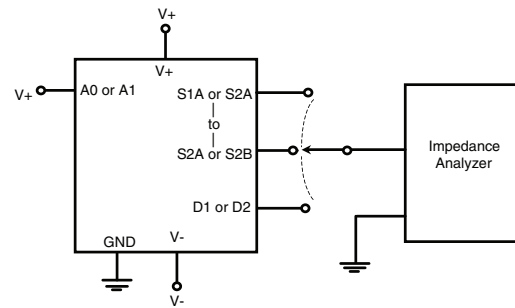
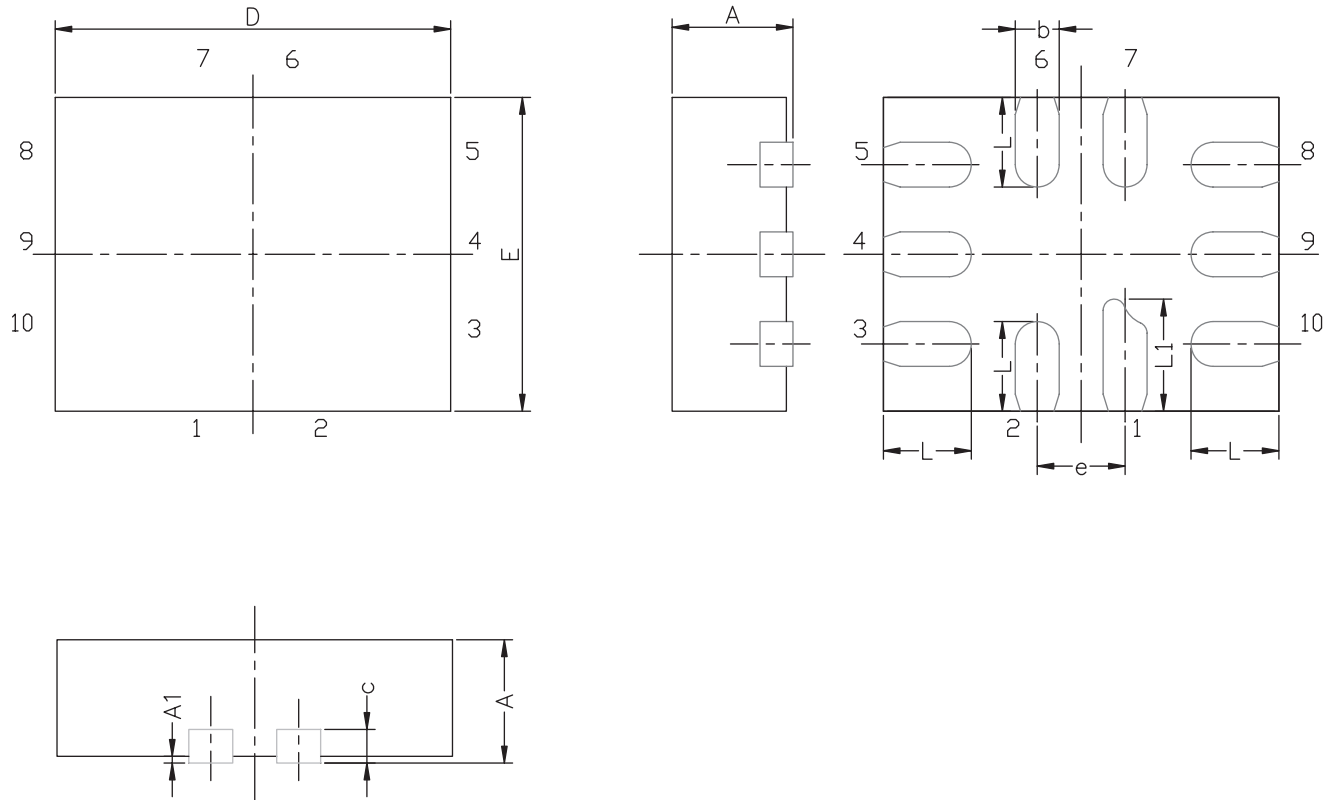

Figure 7. Source/Drain Capacitance

Vishay Siliconix maintains worldwide manufacturing capability. Products may be manufactured at one of several qualified locations. Reliability data for Silicon Technology and Package Reliability represent a composite of all qualified locations. For related documents such as package/tape drawings, part marking, and reliability data, see www.vishay.com/ppg?65159.

MINI QFN-10L CASE OUTLINE



DIM	MILLIMETERS			INCHES		
	MIN.	NAM.	MAX.	MIN.	NAM.	MAX.
A	0.50	0.55	0.60	0.0197	0.0217	0.0236
A1	0.00	-	0.05	0.000	-	0.002
b	0.15	0.20	0.25	0.006	0.008	0.010
c	0.15 REF			0.006 REF		
D	1.75	1.80	1.85	0.069	0.071	0.073
E	1.35	1.40	1.45	0.053	0.055	0.057
e	0.40 BSC			0.016 BSC		
L	0.35	0.40	0.45	0.014	0.016	0.018
L1	0.45	0.50	0.55	0.0177	0.0197	0.0217

ECN T-07039-Rev. A, 12-Feb-07
DWG: 5957

RECOMMENDED MINIMUM PADS FOR MINI QFN 10L

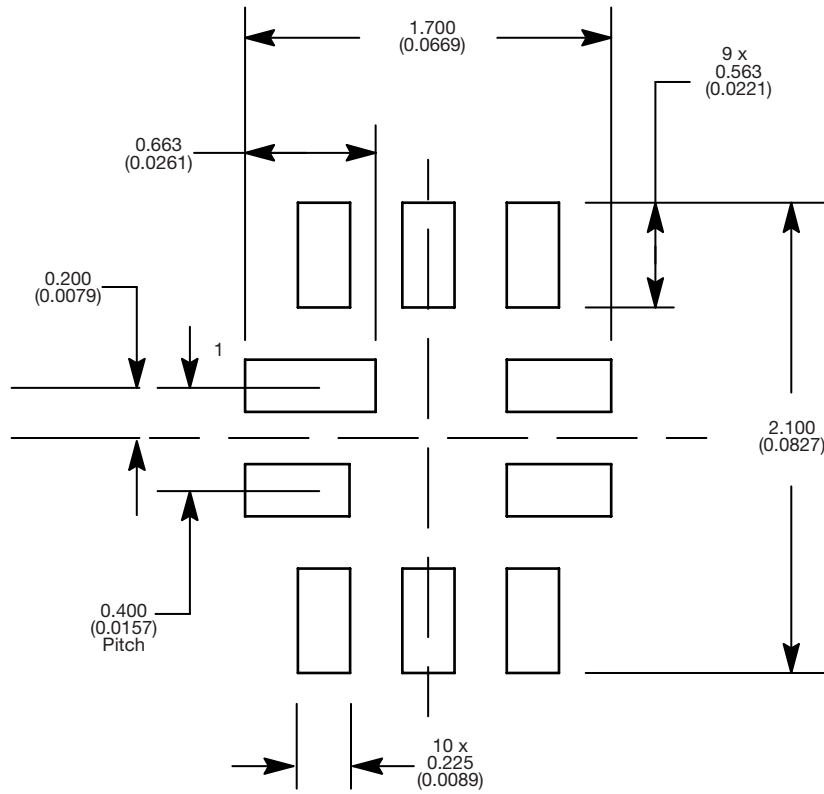

Mounting Footprint
Dimensions in mm (inch)



Disclaimer

ALL PRODUCT, PRODUCT SPECIFICATIONS AND DATA ARE SUBJECT TO CHANGE WITHOUT NOTICE TO IMPROVE RELIABILITY, FUNCTION OR DESIGN OR OTHERWISE.

Vishay Intertechnology, Inc., its affiliates, agents, and employees, and all persons acting on its or their behalf (collectively, "Vishay"), disclaim any and all liability for any errors, inaccuracies or incompleteness contained in any datasheet or in any other disclosure relating to any product.

Vishay makes no warranty, representation or guarantee regarding the suitability of the products for any particular purpose or the continuing production of any product. To the maximum extent permitted by applicable law, Vishay disclaims (i) any and all liability arising out of the application or use of any product, (ii) any and all liability, including without limitation special, consequential or incidental damages, and (iii) any and all implied warranties, including warranties of fitness for particular purpose, non-infringement and merchantability.

Statements regarding the suitability of products for certain types of applications are based on Vishay's knowledge of typical requirements that are often placed on Vishay products in generic applications. Such statements are not binding statements about the suitability of products for a particular application. It is the customer's responsibility to validate that a particular product with the properties described in the product specification is suitable for use in a particular application. Parameters provided in datasheets and/or specifications may vary in different applications and performance may vary over time. All operating parameters, including typical parameters, must be validated for each customer application by the customer's technical experts. Product specifications do not expand or otherwise modify Vishay's terms and conditions of purchase, including but not limited to the warranty expressed therein.

Except as expressly indicated in writing, Vishay products are not designed for use in medical, life-saving, or life-sustaining applications or for any other application in which the failure of the Vishay product could result in personal injury or death. Customers using or selling Vishay products not expressly indicated for use in such applications do so at their own risk. Please contact authorized Vishay personnel to obtain written terms and conditions regarding products designed for such applications.

No license, express or implied, by estoppel or otherwise, to any intellectual property rights is granted by this document or by any conduct of Vishay. Product names and markings noted herein may be trademarks of their respective owners.

Material Category Policy

Vishay Intertechnology, Inc. hereby certifies that all its products that are identified as RoHS-Compliant fulfill the definitions and restrictions defined under Directive 2011/65/EU of The European Parliament and of the Council of June 8, 2011 on the restriction of the use of certain hazardous substances in electrical and electronic equipment (EEE) - recast, unless otherwise specified as non-compliant.

Please note that some Vishay documentation may still make reference to RoHS Directive 2002/95/EC. We confirm that all the products identified as being compliant to Directive 2002/95/EC conform to Directive 2011/65/EU.

Vishay Intertechnology, Inc. hereby certifies that all its products that are identified as Halogen-Free follow Halogen-Free requirements as per JEDEC JS709A standards. Please note that some Vishay documentation may still make reference to the IEC 61249-2-21 definition. We confirm that all the products identified as being compliant to IEC 61249-2-21 conform to JEDEC JS709A standards.