

## Dual Ultrafast Plastic Rectifier

Reverse Voltage 50 to 200V

Forward Current 16.0A

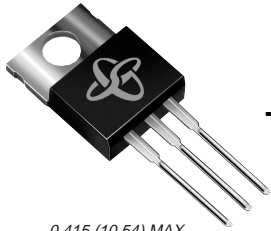

**TO-220AB**

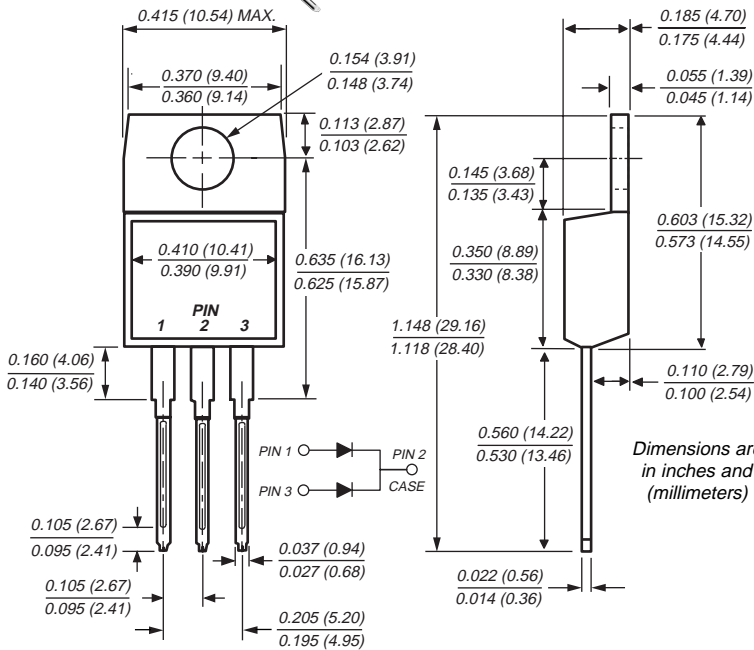

### Features

- Plastic package has Underwriters Laboratory Flammability Classification 94V-0
- Dual rectifier construction, positive centertap
- Glass passivated chip junctions
- Low power loss
- High surge current capability
- Superfast recovery times for high efficiency
- High temperature soldering guaranteed: 250°C, 0.16" (4.06mm) from case for 10 seconds

### Mechanical Data

**Case:** JEDEC TO-220AB molded plastic body over passivated chips

**Terminals:** Plated leads solderable per MIL-STD-750, Method 2026

**Polarity:** As marked

**Mounting Position:** Any

**Mounting Torque:** 10 in-lbs maximum

**Weight:** 0.08 ounce, 2.24 grams

### Maximum Ratings & Thermal Characteristics Ratings at 25°C ambient temperature unless otherwise specified.

Parameter	Symbol	GI2401	GI2402	GI2403	GI2404	Unit
Maximum repetitive peak reverse voltage	V <sub>RRM</sub>	50	100	150	200	V
Maximum RMS voltage	V <sub>RMS</sub>	35	70	105	140	V
Maximum DC blocking voltage	V <sub>DC</sub>	50	100	150	200	V
Maximum average forward rectified current at T <sub>C</sub> = 100°C	I <sub>F(AV)</sub>	16				A
Peak forward surge current 8.3ms single half sine-wave superimposed on rated load (JEDEC Method) at T <sub>C</sub> =125°C	I <sub>FSM</sub>	125				A
Typical thermal resistance (Note 1)	R <sub>θJA</sub> R <sub>θJC</sub>	16 2.2				°C/W
Operating junction and storage temperature range	T <sub>J</sub> , T <sub>STG</sub>	-65 to +150				°C

### Electrical Characteristics Ratings at 25°C ambient temperature unless otherwise specified.

Parameter	Symbol	GI2401	GI2402	GI2403	GI2404	Unit
Maximum instantaneous forward voltage per leg at I <sub>F</sub> = 4A, T <sub>J</sub> = 25°C I <sub>F</sub> = 8A, T <sub>J</sub> = 25°C I <sub>F</sub> = 4A, T <sub>J</sub> = 100°C I <sub>F</sub> = 8A, T <sub>J</sub> = 100°C	V <sub>F</sub>	0.900 0.975 0.800 0.895				V
Maximum DC reverse current at rated DC blocking voltage per leg T <sub>C</sub> = 25°C T <sub>C</sub> = 100°C	I <sub>R</sub>	50 150		5.0 500		μA
Maximum reverse recovery time per leg at I <sub>F</sub> = 0.5A, I <sub>R</sub> = 1.0A, I <sub>rr</sub> = 0.25A	t <sub>rr</sub>	35				ns
Typical junction capacitance per leg at 4V, 1 MHz	C <sub>J</sub>	85				pF

**Notes:** (1) Thermal resistance from junction to ambient and from junction to case per leg mounted on heatsink

## Dual Ultrafast Plastic Rectifier

### Ratings and Characteristic Curves ( $T_A = 25^\circ\text{C}$ unless otherwise noted)

**Fig. 1 – Maximum Forward Current Derating Curve**

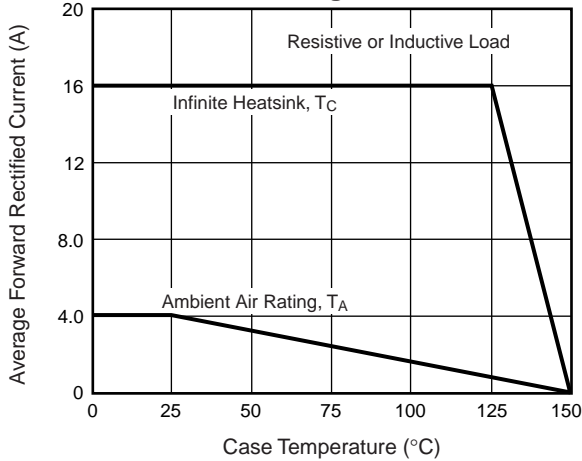

**Fig. 2 – Maximum Non-Repetitive Peak Forward Surge Current Per Leg**

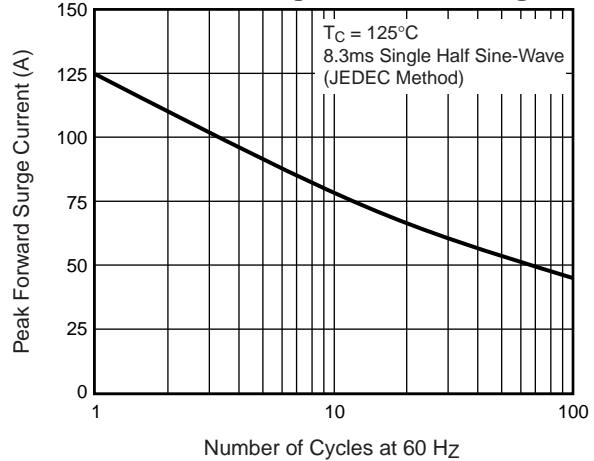

**Fig. 3 – Typical Instantaneous Forward Characteristics Per Leg**

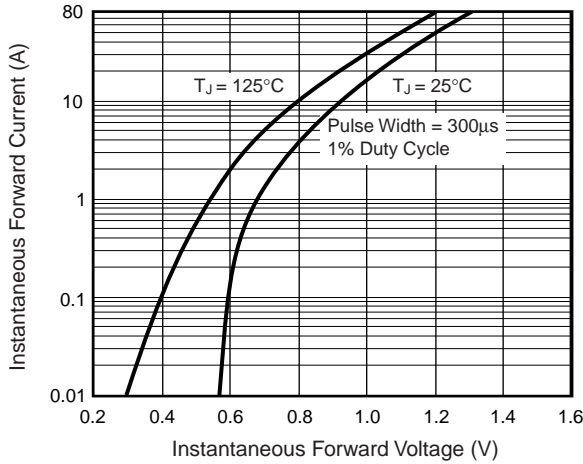

**Fig. 4 – Typical Reverse Leakage Characteristics Per Leg**

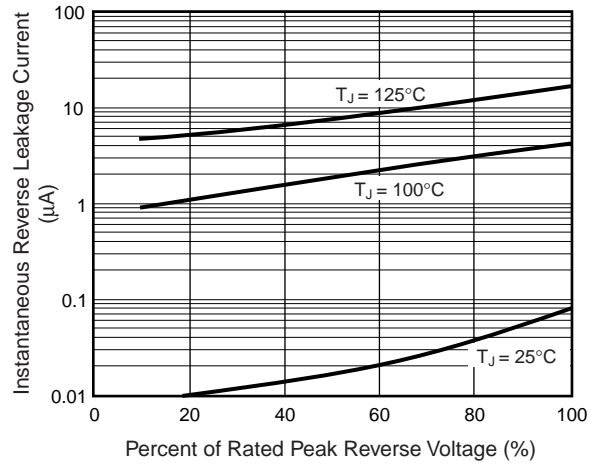

**Fig. 5 – Typical Junction Capacitance Per Leg**

