

APPROVAL SHEET

WW25X, WW20X, WW18X

±1%, ±5%

Thick Film Low ohm power chip resistors

Size 2512, 2010, 1218

*Contents in this sheet are subject to change without prior notice.

FEATURE

1. High power rating and compact size
2. High reliability and stability
3. Reduced size of final equipment
4. RoHS compliant and Lead free products

APPLICATION

- Power supply
- PDA
- Digital meter
- Computer
- Automotives
- Battery charger
- DC-DC power converter

DESCRIPTION

The resistors are constructed in a high grade ceramic body (aluminum oxide). Internal metal electrodes are added at each end and connected by a resistive paste that is applied to the top surface of the substrate. The composition of the paste is adjusted to give the approximate resistance required and the value is trimmed to nominated value within tolerance which controlled by laser trimming of this resistive layer.

The resistive layer is covered with a protective coat. Finally, the two external end terminations are added. For ease of soldering the outer layer of these end terminations is a Lead-tin alloy.

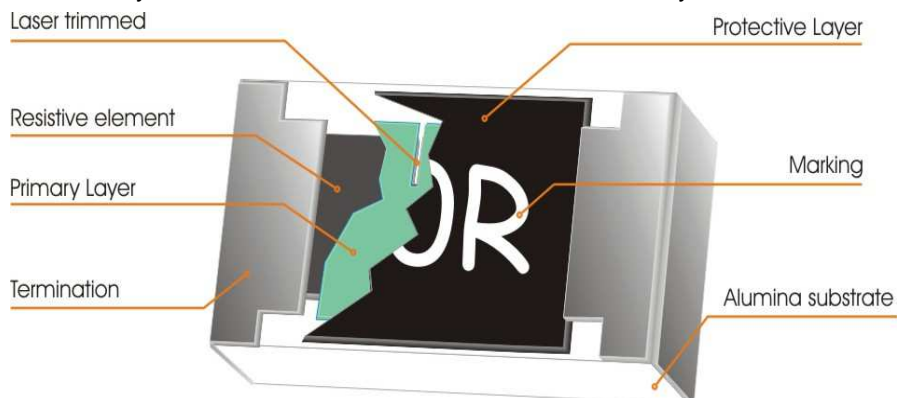

Fig 1. Construction of 2512, 2010 Chip-R

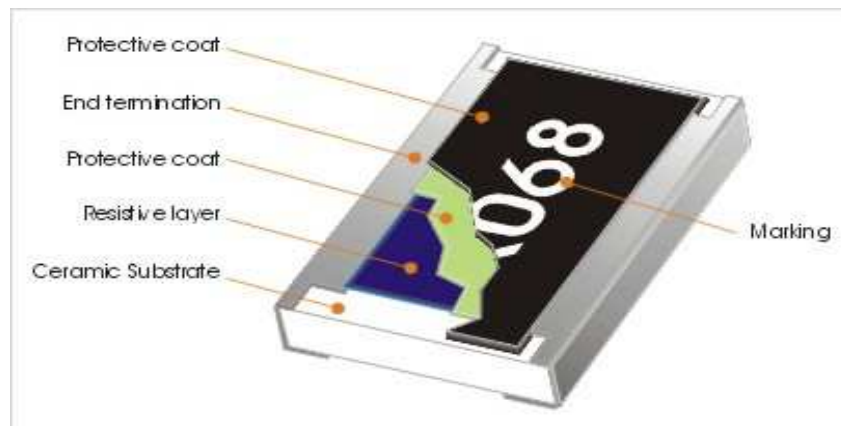

Fig 2. Construction of a 1218 Chip-R

QUICK REFERENCE DATA

Item	General Specification					
	WW25X		WW20X		WW18X	
Series No.	2512 (6432)		2010(5025)		1218(3248)	
Resistance Tolerance	±5% (E24)	±1% (E96)	±5% (E24)	±1% (E96)	±5% (E24)	±1% (E96)
Resistance Range	0.02Ω ~ 0.91Ω	0.02Ω ~ 0.976Ω	0.02Ω ~ 0.91Ω	0.02Ω ~ 0.976Ω	0.02Ω ~ 0.91Ω	0.02Ω ~ 0.976Ω
TCR (ppm/°C)						
0.02Ω ≤ Rn < 0.05Ω	≤ 2100 ppm/°C				≤ 1500 ppm/°C	
0.05Ω ≤ Rn < 0.10Ω	≤ 1000 ppm/°C				≤ 1000 ppm/°C	
0.10Ω ≤ Rn < 0.50Ω	≤ 500 ppm/°C				≤ 500 ppm/°C	
0.50Ω ≤ Rn < 1Ω	≤ 400 ppm/°C				≤ 300 ppm/°C	
Max. dissipation at T _{amb} =70°C	1 W		0.5 W		1 W	
Max. Operation Voltage (DC or RMS)	250V		200V		200V	
Max. Overload Voltage (DC or RMS)	500V		400V		400V	
Climatic category (IEC 60068)	55/155/56		55/155/56		55/155/56	

Note :

- This is the maximum voltage that may be continuously supplied to the resistor element, see "IEC publication 60115-8"
- Max. Operation Voltage : So called RCWV (Rated Continuous Working Voltage) is determined by

$$RCWV = \sqrt{\text{Rated Power} \times \text{Resistance Value}}$$
or Max. RCWV listed above, whichever is lower.
- Tolerance of TCR=±200ppm/°C

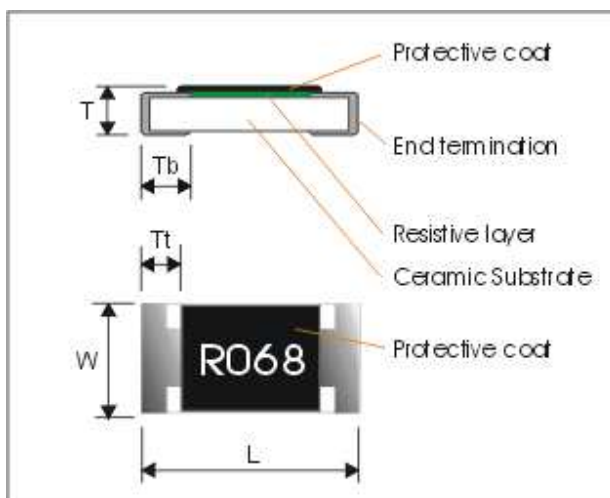
MECHANICAL DATA(unit : mm)

Symbol \ size	2512	2010	1218
L	6.40±0.20	5.00±0.20	3.05±0.15
W	3.20±0.20	2.50±0.20	4.60±0.20
T	0.60±0.10	0.55±0.10	0.55±0.10
Tt	0.65±0.25	0.65±0.25	0.45±0.25
Tb	0.90±0.25	0.60±0.25	0.50±0.25

MARKING

Each resistor is marked with a four-digit code on the protective coating to designate the nominal resistance value.

Example:

$$R010 = 0.01\Omega$$

$$R510 = 0.51\Omega$$

FUNCTIONAL DESCRIPTION

Product characterization

Standard values of nominal resistance are taken from the E96 & E24 series for resistors with a tolerance of $\pm 5\%$ & $\pm 1\%$. The values of the E24/E96 series are in accordance with "IEC publication 60063".

Derating curve

The power that the resistor can dissipate depends on the operating temperature; see Fig.3

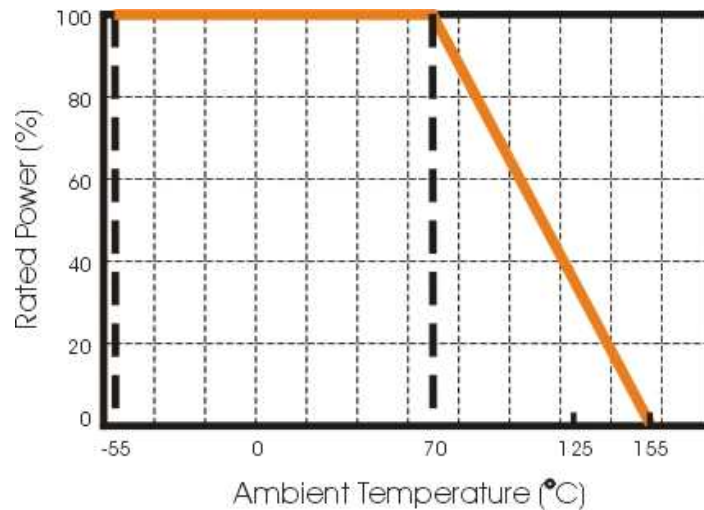

Fig 3. Max. dissipation in percentage of rated power as a function of the ambient temperature

MOUNTING

Due to their rectangular shapes and small tolerances, Surface Mountable Resistors are suitable for handling by automatic placement systems.

Chip placement can be on ceramic substrates and printed-circuit boards (PCBs).

Electrical connection to the circuit is by individual soldering condition.

The end terminations guarantee a reliable contact.

SOLDERING CONDITION

The robust construction of chip resistors allows them to be completely immersed in a solder bath of 260°C for 10 seconds. Therefore, it is possible to mount Surface Mount Resistors on one side of a PCB and other discrete components on the reverse (mixed PCBs).

Surface Mount Resistors are tested for solderability at 235°C during 2 seconds. The test condition for no leaching is 260°C for 30 seconds. Typical examples of soldering processes that provide reliable joints without any damage are given in Fig 4.

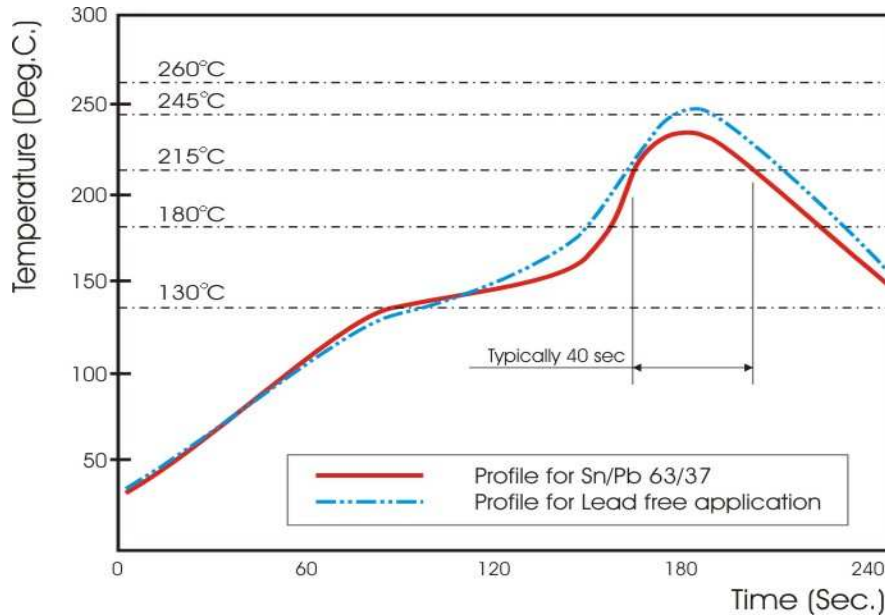

Fig 4. Infrared soldering profile for Chip Resistors

CATALOGUE NUMBERS

The resistors have a catalogue number starting with .

WW25	X	R022	J	T	L
Size code	Type code	Resistance code	Tolerance	Packaging code	Termination code
WW25 : 2512 WW20 : 2010 WW18 : 1218	X : Normal	E96 +E24: R is first digit followed by 3 significant digits. 0.020Ω = R020 0.510Ω = R510 0.025Ω = R025	J : ±5% F : ±1%	T : Reeled	L = Sn base (lead free)

TEST AND REQUIREMENTS(JIS C 5201-1 : 1998)

Essentially all tests are carried out according to the schedule of IEC publication 115-8, category **LCT/UCT/56**(rated temperature range : Lower Category Temperature, Upper Category Temperature; damp heat, long term, 56 days). The testing also meets the requirements specified by EIA, EIAJ and JIS.

The tests are carried out in accordance with IEC publication 68, "Recommended basic climatic and mechanical robustness testing procedure for electronic components" and under standard atmospheric conditions according to IEC 60068-1, subclause 5.3. Unless otherwise specified, the following value supplied :

Temperature: 15°C to 35°C.

Relative humidity: 45% to 75%.

Air pressure: 86kPa to 106 kPa (860 mbar to 1060 mbar).

All soldering tests are performed with mildly activated flux.

TEST	PROCEDURE	REQUIREMENT
Temperature Coefficient of Resistance(T.C.R) Clause 4.8	Natural resistance change per change in degree centigrade. $\frac{R_2 - R_1}{R_1(t_2 - t_1)} \times 10^6 \text{ (ppm/}^\circ\text{C)}$ $t_1 : 20^\circ\text{C}+5^\circ\text{C}-1^\circ\text{C}$ R_1 : Resistance at reference temperature R_2 : Resistance at test temperature	Refer to "QUICK REFERENCE DATA"
Short time overload (S.T.O.L) Clause 4.13	Permanent resistance change after a 5second application of a voltage 2.5 times RCWV or the maximum overload voltage specified in the above list, whichever is less.	$\Delta R/R$ max. $\pm(2\%+0.005\Omega)$
Resistance to soldering heat(R.S.H) Clause 4.18	Un-mounted chips completely immersed for 10 ± 1 second in a SAC solder bath at $260^\circ\text{C} \pm 5^\circ\text{C}$	no visible damage $\Delta R/R$ max. $\pm(1\%+0.005\Omega)$
Solderability Clause 4.17	Un-mounted chips completely immersed for 2 ± 0.5 second in a SAC solder bath at $235^\circ\text{C} \pm 5^\circ\text{C}$	good tinning (>95% covered) no visible damage
Temperature cycling Clause 4.19	30 minutes at $-55^\circ\text{C} \pm 3^\circ\text{C}$, 2~3 minutes at $20^\circ\text{C}+5^\circ\text{C}-1^\circ\text{C}$, 30 minutes at $+155^\circ\text{C} \pm 3^\circ\text{C}$, 2~3 minutes at $20^\circ\text{C}+5^\circ\text{C}-1^\circ\text{C}$, total 5 continuous cycles	no visible damage $\Delta R/R$ max. $\pm(1\%+0.005\Omega)$
Load life (endurance) Clause 4.25	1000 +48/-0 hours, loaded with RCWV or Vmax in chamber controller $70\pm 2^\circ\text{C}$, 1.5 hours on and 0.5 hours off	$\Delta R/R$ max. $\pm(3\%+0.005\Omega)$
Load life in Humidity Clause 4.24	1000 +48/-0 hours, loaded with RCWV or Vmax in humidity chamber controller at $40^\circ\text{C} \pm 2^\circ\text{C}$ and 90~95% relative humidity, 1.5hours on and 0.5 hours off	$\Delta R/R$ max. $\pm(3\%+0.005\Omega)$
Bending strength Clause 4.33	Resistors mounted on a 90mm glass epoxy resin PCB(FR4); bending : 2 mm, once for 10 seconds	$\Delta R/R$ max. $\pm(1\%+0.005\Omega)$
Adhesion Clause 4.32	Pressurizing force: 5N, Test time: 10 ± 1 sec.	No remarkable damage or removal of the terminations
Insulation Resistance Clause 4.6	Apply the maximum overload voltage (DC) for 1minute	$R \geq 10G\Omega$
Dielectric Withstand Voltage Clause 4.7	Apply the maximum overload voltage (AC) for 1 minute	No breakdown or flashover

PACKAGING

Plastic Tape specifications (unit :mm)

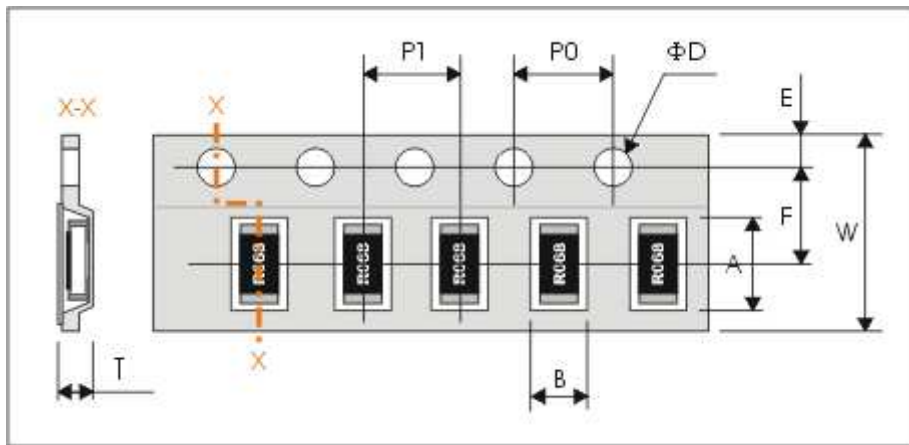

Symbol	A	B	W	F	E
2512	6.90±0.20	3.60±0.20	12.00±0.30	5.50±0.1	1.75±0.10
2010	5.50±0.20	2.80±0.20			
1218	4.90±0.20	3.55±0.30			

Symbol	P1	P0	ΦD	T
2512	4.00±0.10	4.00±0.10	Φ1.50 ^{+0.1} _{-0.0}	Max. 1.2
2010				Max. 1.2
1218	8.00±0.10	8.00±0.10		1.30±0.20

Reel dimensions

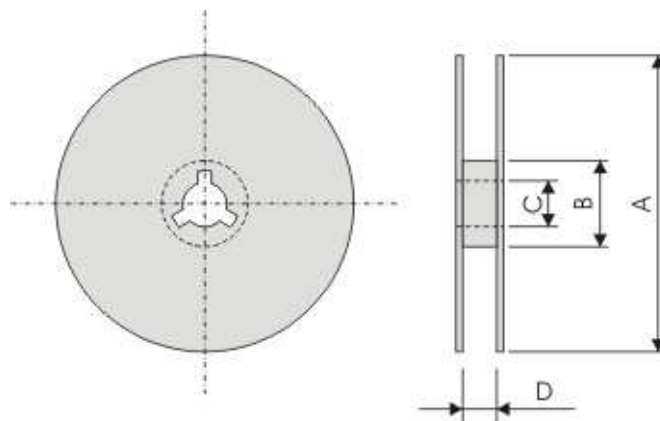

Symbol	A	B	C	D
(unit : mm)	Φ178.0±2.0	Φ60.0±1.0	13.0±0.2	14.0±0.2

Taping quantity

- WW20, WW25 by plastic tape taping 4,000 pcs per reel.
- WW18 by plastic tape taping 3,000 pcs per reel