

Nonvolatile Static RAM

FEATURES

- High Performance CMOS
 - 120ns RAM Access Time
- High Reliability
 - Store Cycles: 1,000,000
 - Data Retention: 100 Years
- Low Power Consumption
 - Active: 40mA Max.
 - Standby: 100µA Max.
- Infinite Array Recall, RAM Read and Write Cycles
- Nonvolatile Store Inhibit: $V_{CC} = 3.5V$ Typical
- Fully TTL and CMOS Compatible
- JEDEC Standard 18-Pin 300-mil DIP
- 100% Compatible with X2210
 - With Timing Enhancements

DESCRIPTION

The X22C10 is a 64 x 4 CMOS NOVRAM featuring a high-speed static RAM overlaid bit-for-bit with a non-volatile E²PROM. The NOVRAM design allows data to be easily transferred from RAM to E²PROM (STORE) and from E²PROM to RAM (RECALL). The STORE operation is completed within 5ms or less and the RECALL is completed within 1µs.

Xicor NOVRAMs are designed for unlimited write operations to the RAM, either RECALLs from E²PROM or writes from the host. The X22C10 will reliably endure 1,000,000 STORE cycles. Inherent data retention is greater than 100 years.

FUNCTIONAL DIAGRAM

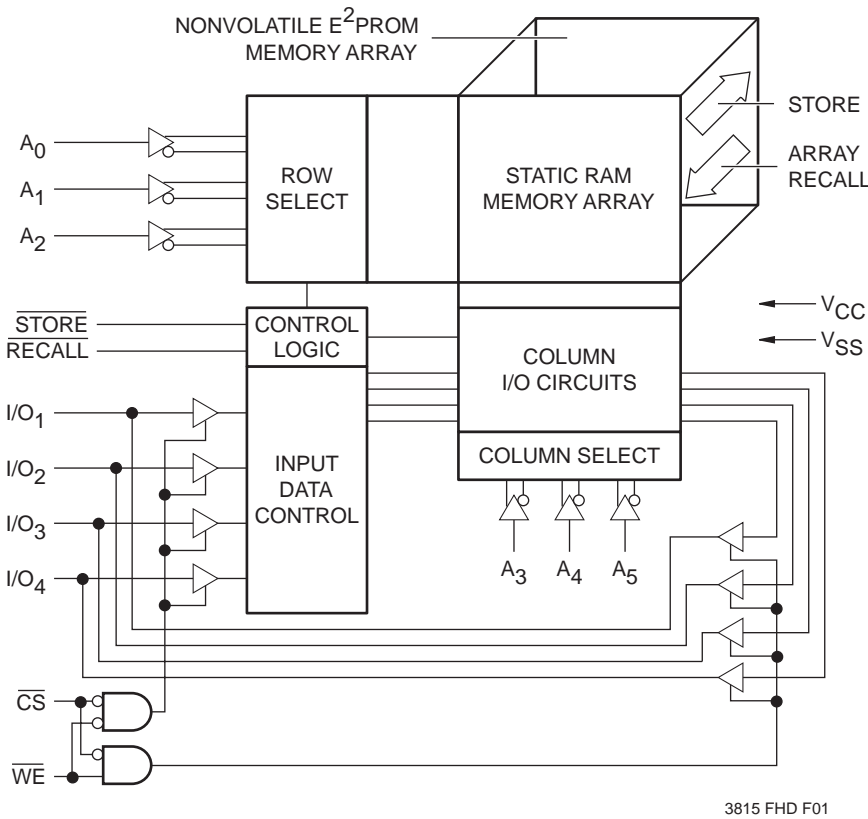

3815 FHD F01

PIN CONFIGURATION

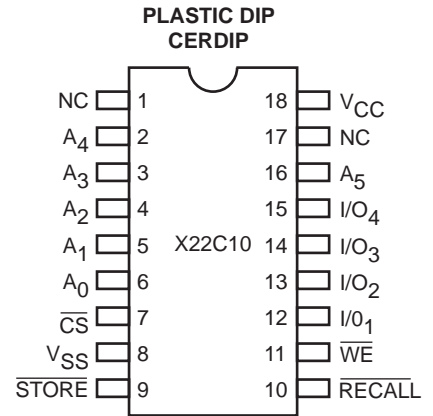

3815 FHD F02

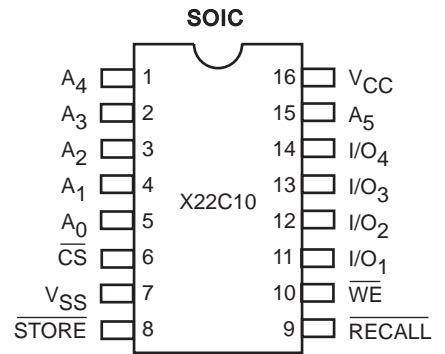

3815 FHD F08.1

X22C10

PIN DESCRIPTIONS AND DEVICE OPERATION

Addresses (A₀–A₅)

The address inputs select a 4-bit memory location during a read or write operation.

Chip Select (\overline{CS})

The Chip Select input must be LOW to enable read or write operations with the RAM array. \overline{CS} HIGH will place the I/O pins in the high impedance state.

Write Enable (\overline{WE})

The Write Enable input controls the I/O buffers, determining whether a RAM read or write operation is enabled. When \overline{CS} is LOW and \overline{WE} is HIGH, the I/O pins will output data from the selected RAM address locations. When both \overline{CS} and \overline{WE} are LOW, data presented at the I/O pins will be written to the selected address location.

Data In/Data Out (I/O₁–I/O₄)

Data is written to or read from the X22C10 through the I/O pins. The I/O pins are placed in the high impedance state when either \overline{CS} is HIGH or during either a store or recall operation.

\overline{STORE}

The \overline{STORE} input, when LOW, will initiate the transfer of the entire contents of the RAM array to the E²PROM array. The \overline{WE} and \overline{RECALL} inputs are inhibited during the store cycle. The store operation is completed in 5ms or less.

A store operation has priority over RAM read/write operations. If \overline{STORE} is asserted during a read operation, the read will be discontinued. If \overline{STORE} is asserted during a RAM write operation, the write will be immediately terminated and the store performed. The data at the RAM address that was being written will be unknown in both the RAM and E²PROM arrays.

\overline{RECALL}

The \overline{RECALL} input, when LOW, will initiate the transfer of the entire contents of the E²PROM array to the RAM array. The transfer of data will be completed in 1 μ s or less.

An array recall has priority over RAM read/write operations and will terminate both operations when \overline{RECALL} is asserted. \overline{RECALL} LOW will also inhibit the \overline{STORE} input.

Automatic Recall

Upon power-up the X22C10 will automatically recall data from the E²PROM array into the RAM array.

Write Protection

The X22C10 has three write protect features that are employed to protect the contents of the nonvolatile memory.

- V_{CC} Sense—All functions are inhibited when V_{CC} is <3.5V typical.
- Write Inhibit—Holding either \overline{STORE} HIGH or \overline{RECALL} LOW during power-up or power-down will prevent an inadvertent store operation and E²PROM data integrity will be maintained.
- Noise Protection—A \overline{STORE} pulse of typically less than 20ns will not initiate a store cycle.

PIN NAMES

Symbol	Description
A ₀ –A ₅	Address Inputs
I/O ₁ –I/O ₄	Data Inputs/Outputs
\overline{WE}	Write Enable
\overline{CS}	Chip Select
\overline{RECALL}	Recall
\overline{STORE}	Store
V _{CC}	+5V
V _{SS}	Ground
NC	No Connect

3815 PGM T01

X22C10

ABSOLUTE MAXIMUM RATINGS

Temperature under Bias	-65°C to +135°C
Storage Temperature	-65°C to +150°C
Voltage on any Pin with Respect to V_{SS}	-1V to +7V
D.C. Output Current	5mA
Lead Temperature (Soldering, 10 seconds)	300°C

COMMENT

Stresses above those listed under “Absolute Maximum Ratings” may cause permanent damage to the device. This is a stress rating only and the functional operation of the device at these or any other conditions above those indicated in the operational sections of this specification is not implied. Exposure to absolute maximum rating conditions for extended periods may affect device reliability.

RECOMMENDED OPERATING CONDITIONS

Temperature	Min.	Max.
Commercial	0°C	+70°C
Industrial	-40°C	+85°C
Military	-55°C	+125°C

3815 PGM T12.1

Supply Voltage	Limits
X22C10	5V ±10%

3815 PGM T13

D.C. OPERATING CHARACTERISTICS (Over the recommended operating conditions, unless otherwise specified.)

Symbol	Parameter	Limits		Units	Test Conditions
		Min.	Max.		
I_{CC}	V_{CC} Supply Current, RAM Read/Write		40	mA	$\overline{CS} = V_{IL}$, I/Os = Open, All Others = V_{IH} , Addresses = 0.4V/2.4V Levels @ $f = 8\text{MHz}$
I_{SB1}	V_{CC} Standby Current (TTL Inputs)		2	mA	Store or Recall Functions Not Active, I/Os = Open, All Other Inputs = V_{IH}
I_{SB2}	V_{CC} Standby Current (CMOS Inputs)		100	μA	Store or Recall functions Not Active, I/Os = Open, All Other Inputs = $V_{CC} - 0.3\text{V}$
I_{LI}	Input Leakage Current		10	μA	$V_{IN} = V_{SS}$ to V_{CC}
I_{LO}	Output Leakage Current		10	μA	$V_{OUT} = V_{SS}$ to V_{CC}
$V_{IL}^{(2)}$	Input LOW Voltage	-1	0.8	V	
$V_{IH}^{(2)}$	Input HIGH Voltage	2	$V_{CC} + 1$	V	
V_{OL}	Output LOW Voltage		0.4	V	$I_{OL} = 4.2\text{mA}$
V_{OH}	Output HIGH Voltage	2.4		V	$I_{OH} = -2\text{mA}$

3815 PGM T02.3

CAPACITANCE $T_A = +25^\circ\text{C}$, $f = 1\text{MHz}$, $V_{CC} = 5\text{V}$

Symbol	Parameter	Max.	Units	Test Conditions
$C_{I/O}^{(1)}$	Input/Output Capacitance	8	pF	$V_{I/O} = 0\text{V}$
$C_{IN}^{(1)}$	Input Capacitance	6	pF	$V_{IN} = 0\text{V}$

3815 PGM T03

- Notes:** (1) This parameter is periodically sampled and not 100% tested.
 (2) V_{IL} min. and V_{IH} max. are for reference only and are not tested.

X22C10

MODE SELECTION

\overline{CE}	\overline{WE}	\overline{RECALL}	\overline{STORE}	I/O	Mode
H	X	H	H	Output High Z	Not Selected ⁽³⁾
L	H	H	H	Output Data	Read RAM
L	L	H	H	Input Data HIGH	Write "1" RAM
L	L	H	H	Input Data LOW	Write "0" RAM
X	H	L	H	Output High Z	Array Recall
H	X	L	H	Output High Z	Array Recall
X	H	H	L	Output High Z	Nonvolatile Store ⁽⁴⁾
H	X	H	L	Output High Z	Nonvolatile Store ⁽⁴⁾

3815 PGM T05.1

ENDURANCE AND DATA RETENTION

Parameter	Min.	Units
Endurance	100,000	Data Changes Per Bit
Store Cycles	1,000,000	Store Cycles
Data Retention	100	Years

3815 PGM T06

POWER-UP TIMING

Symbol	Parameter	Max.	Units
$t_{PUR}^{(5)}$	Power-up to Read Operation	100	μs
$t_{PUW}^{(5)}$	Power-up to Write or Store Operation	5	ms

3815 PGM T07

EQUIVALENT A.C. LOAD CIRCUIT

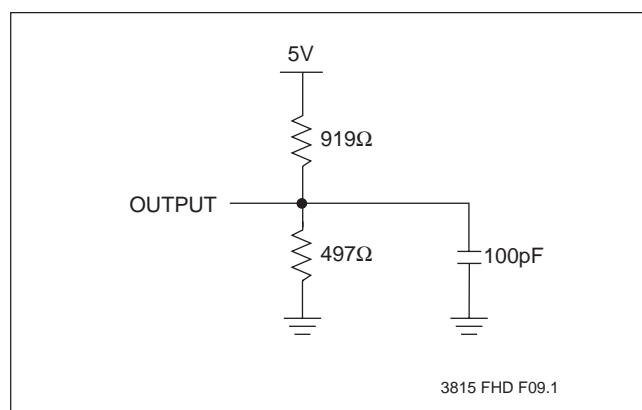

A.C. CONDITIONS OF TEST

Input Pulse Levels	0V to 3V
Input Rise and Fall Times	10ns
Input and Output Timing Levels	1.5V

3815 PGM T04.1

- Notes:**
- (3) Chip is deselected but may be automatically completing a store cycle.
 - (4) $\overline{STORE} = \text{LOW}$ is required only to initiate the store cycle, after which the store cycle will be automatically completed (e.g. $\overline{STORE} = \text{X}$).
 - (5) t_{PUR} and t_{PUW} are the delays required from the time V_{CC} is stable until the specified operation can be initiated. These parameters are periodically sampled and not 100% tested.

X22C10

A.C. CHARACTERISTICS (Over the recommended operating conditions, unless otherwise specified.)

Read Cycle Limits

Symbol	Parameter	Min.	Max.	Units
t_{RC}	Read Cycle Time	120		ns
t_{AA}	Access Time		120	ns
t_{CO}	Chip Select to Output Valid		120	ns
t_{OH}	Output Hold from Address Change	0		ns
$t_{LZ}^{(6)}$	Chip Select to Output in Low Z	0		ns
$t_{HZ}^{(6)}$	Chip Deselect to Output in High Z		50	ns

3815 PGM T08

Read Cycle

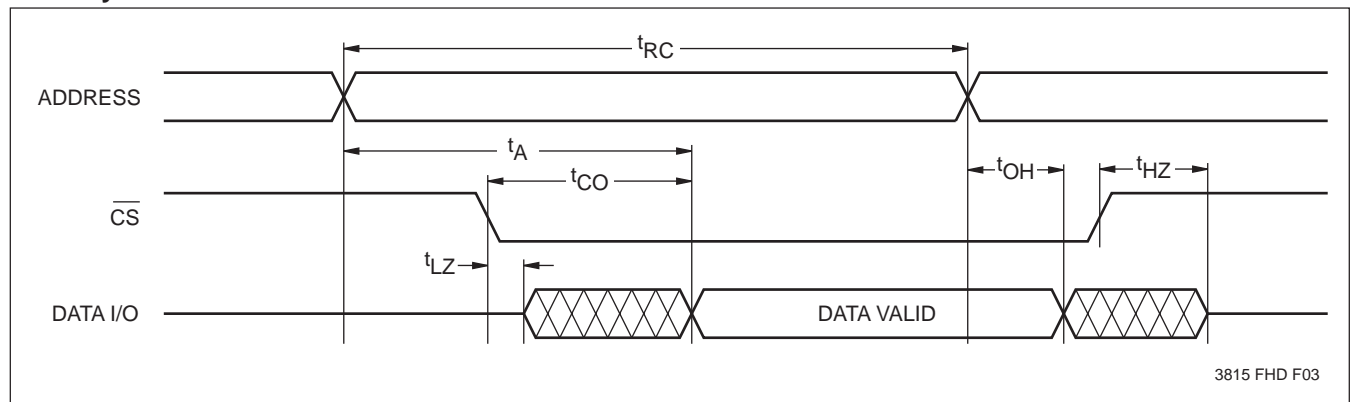

3815 FHD F03

Note: (6) t_{LZ} min. and t_{HZ} min. are periodically sampled and not 100% tested.

X22C10

Write Cycle Limits

Symbol	Parameter	Min.	Max.	Units
t_{WC}	Write Cycle Time	120		ns
t_{CW}	Chip Select to End of Write	90		ns
t_{AS}	Address Setup Time	0		ns
t_{WP}	Write Pulse Width	90		ns
t_{WR}	Write Recovery Time	0		ns
t_{DW}	Data Valid to End of Write	40		ns
t_{DH}	Data Hold Time	0		ns
t_{WZ}	Write Enable to Output in High Z		50	ns
t_{OW}	Output Active from End of Write	0		ns

3815 PGM T09

Write Cycle

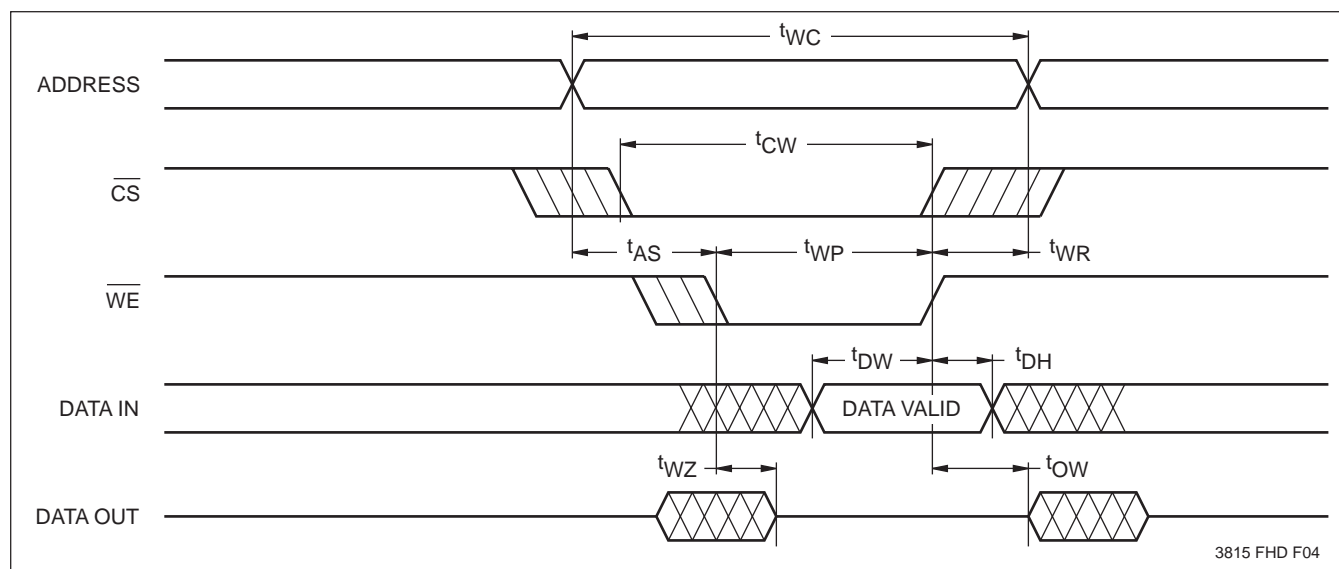

Early Write Cycle

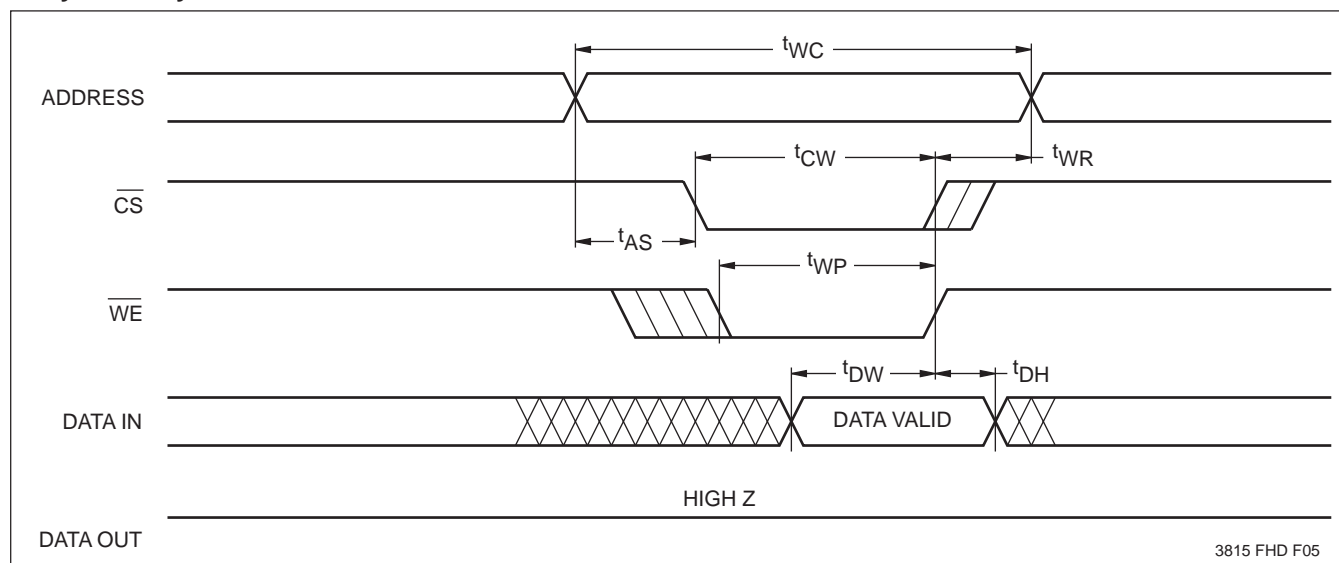

X22C10

Recall Cycle Limits

Symbol	Parameter	Min.	Max.	Units
t_{RCC}	Array Recall Time		1	μs
$t_{RCP}^{(7)}$	Recall Pulse Width	90		ns
t_{RCZ}	Recall to Output in High Z		50	ns
t_{ORC}	Output Active from End of Recall	0		ns
t_{ARC}	Recalled Data Access Time from End of Recall		150	ns

3815 PGM T10

Recall Cycle

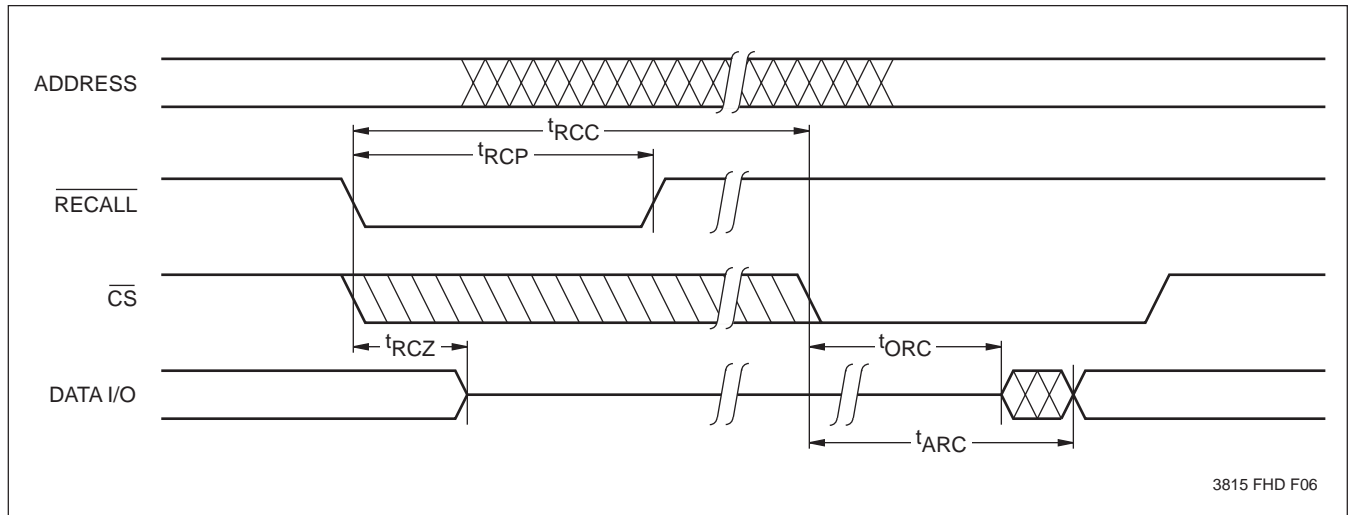

3815 FHD F06

Note: (7) Recall rise time must be less than $1\mu\text{s}$.

X22C10

Store Cycle Limits

Symbol	Parameter	Min.	Max.	Units
t_{STC}	Internal Store Time		5	ms
t_{STP}	Store Pulse Width	90		ns
t_{STZ}	Store to Output in High Z		50	ns
t_{OST}	Output Active from End of Store	0		ns

3815 PGM T11

Store Cycle Limits

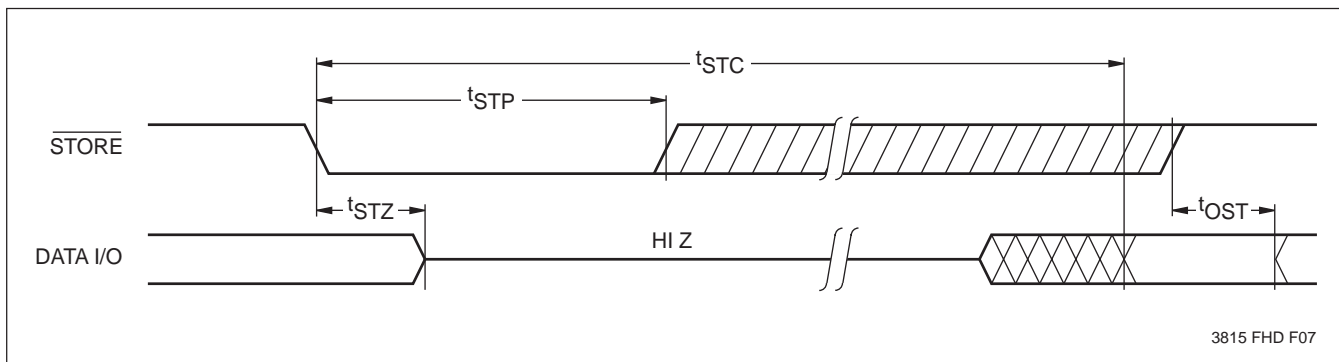

SYMBOL TABLE

WAVEFORM	INPUTS	OUTPUTS
	Must be steady	Will be steady
	May change from LOW to HIGH	Will change from LOW to HIGH
	May change from HIGH to LOW	Will change from HIGH to LOW
	Don't Care: Changes Allowed	Changing: State Not Known
	N/A	Center Line is High Impedance

X22C10

PACKAGING INFORMATION

16-LEAD PLASTIC SMALL OUTLINE GULL WING PACKAGE TYPE S

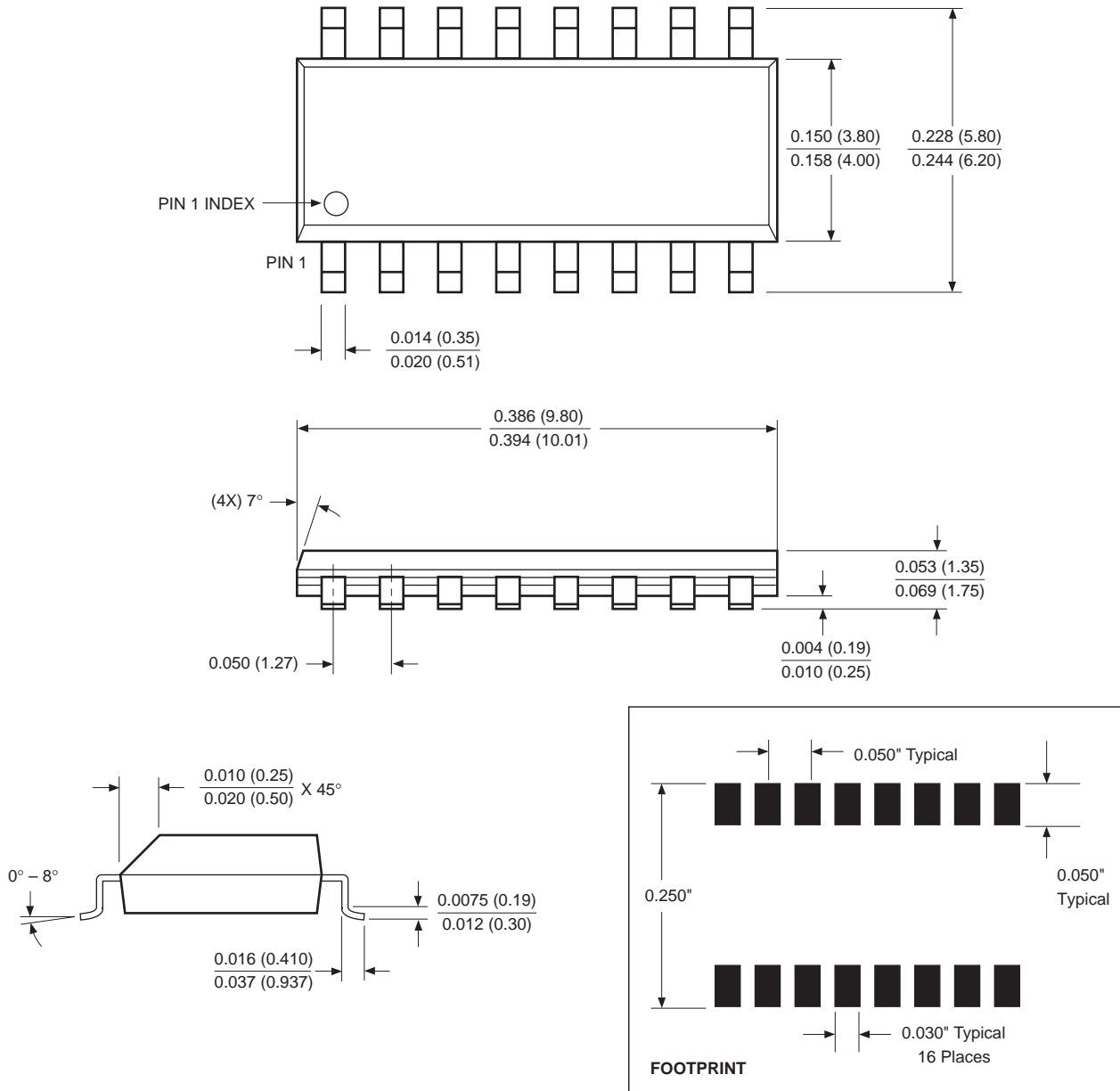

X22C10

PACKAGING INFORMATION

18-LEAD HERMETIC DUAL IN-LINE PACKAGE TYPE D

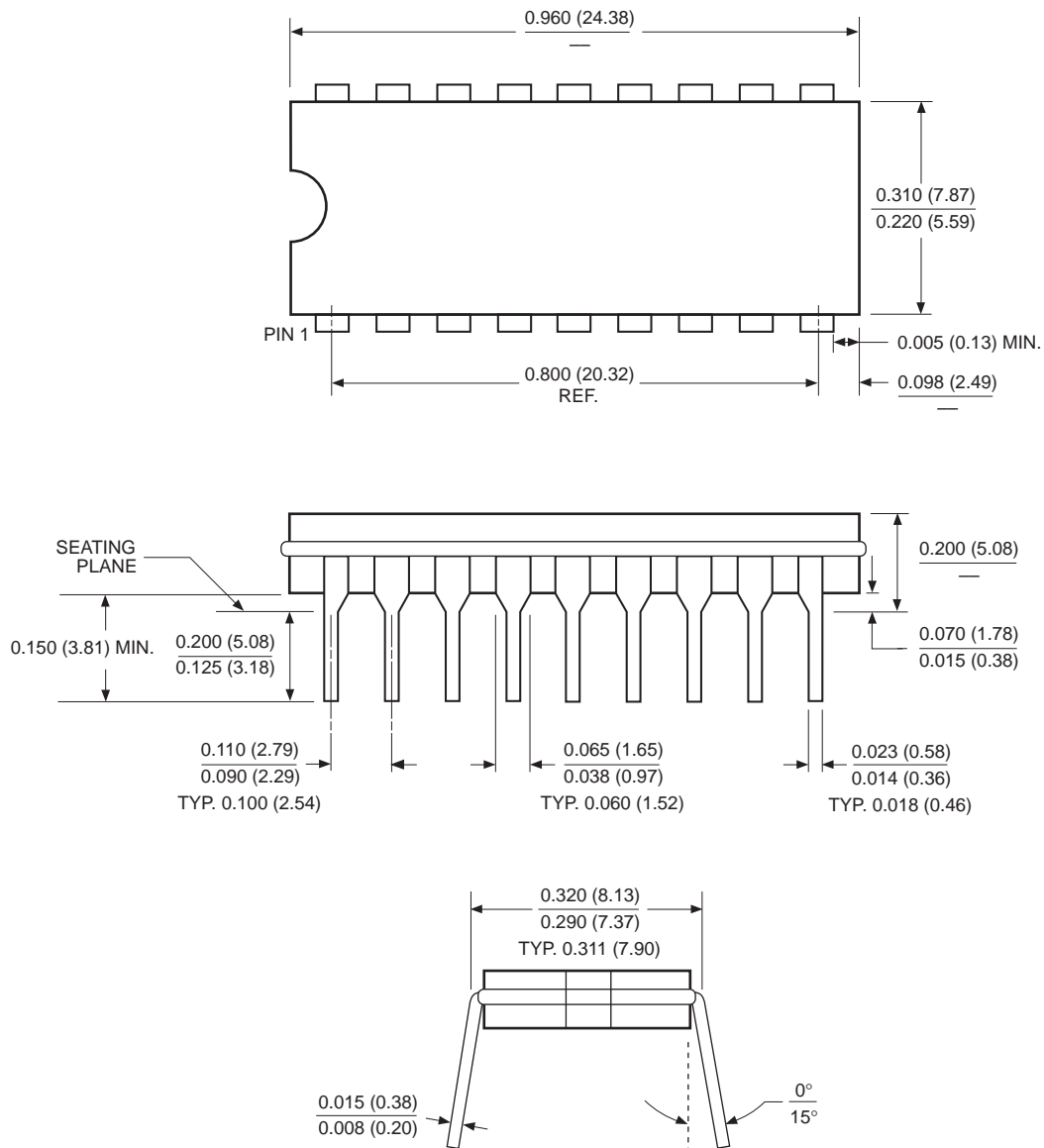

NOTE: ALL DIMENSIONS IN INCHES (IN PARENTHESES IN MILLIMETERS)

3926 FHD F06

X22C10

PACKAGING INFORMATION

18-LEAD PLASTIC DUAL IN-LINE PACKAGE TYPE P

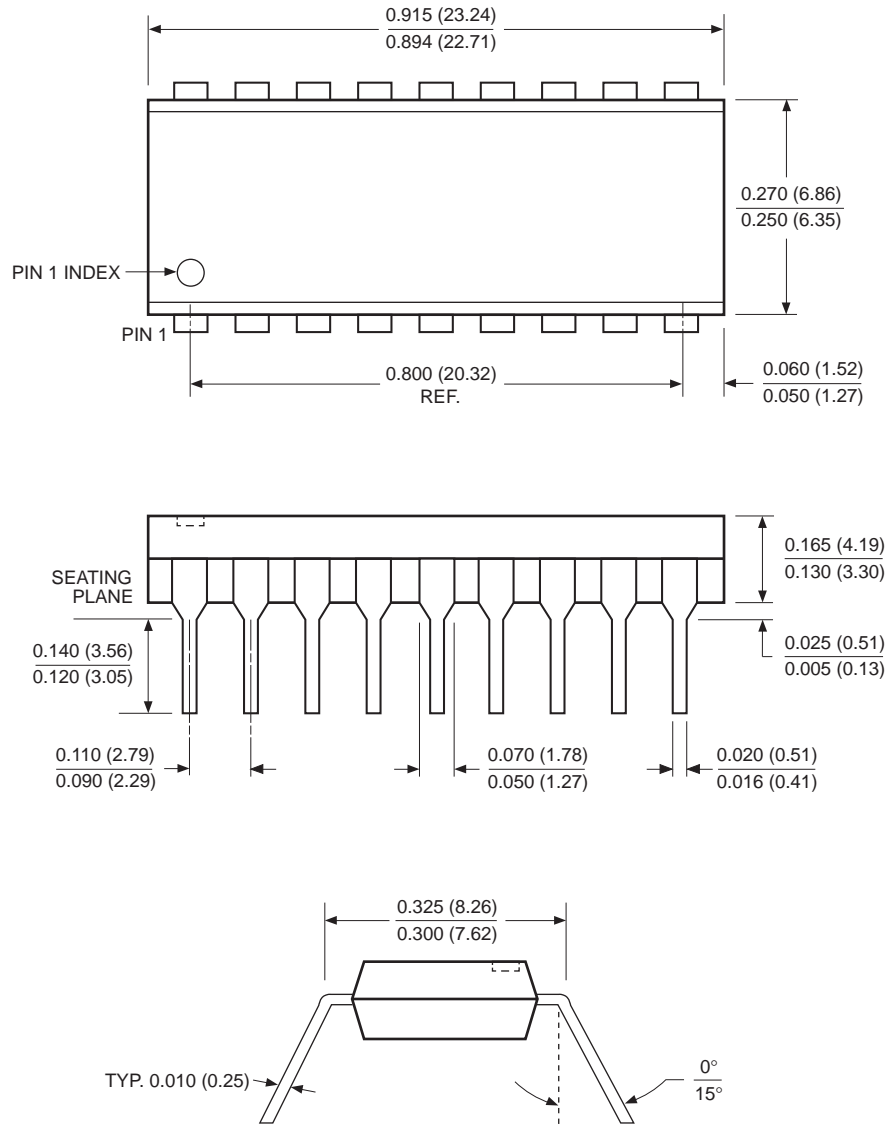

NOTE:

1. ALL DIMENSIONS IN INCHES (IN PARENTHESES IN MILLIMETERS)
2. PACKAGE DIMENSIONS EXCLUDE MOLDING FLASH

3926 FHD F02

X22C10

ORDERING INFORMATION

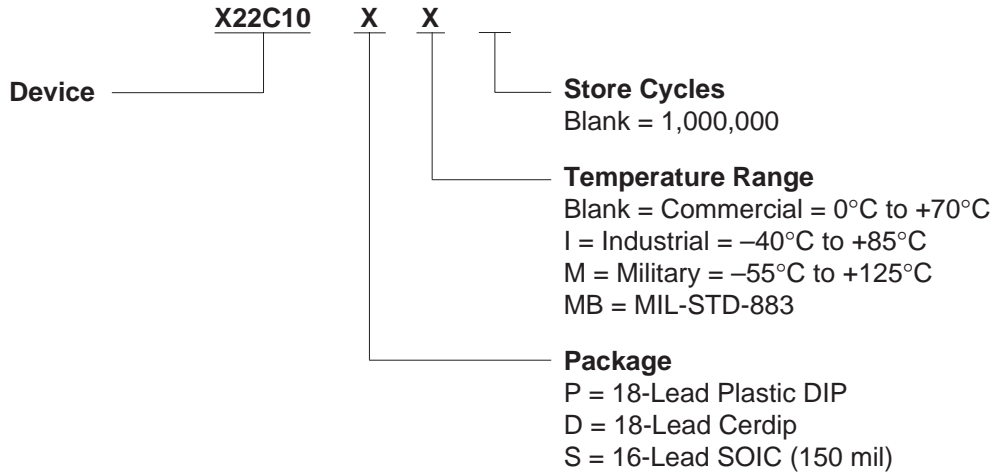

LIMITED WARRANTY

Devices sold by Xicor, Inc. are covered by the warranty and patent indemnification provisions appearing in its Terms of Sale only. Xicor, Inc. makes no warranty, express, statutory, implied, or by description regarding the information set forth herein or regarding the freedom of the described devices from patent infringement. Xicor, Inc. makes no warranty of merchantability or fitness for any purpose. Xicor, Inc. reserves the right to discontinue production and change specifications and prices at any time and without notice.

Xicor, Inc. assumes no responsibility for the use of any circuitry other than circuitry embodied in a Xicor, Inc. product. No other circuits, patents, licenses are implied.

U.S. PATENTS

Xicor products are covered by one or more of the following U.S. Patents: 4,263,664; 4,274,012; 4,300,212; 4,314,265; 4,326,134; 4,393,481; 4,404,475; 4,450,402; 4,486,769; 4,488,060; 4,520,461; 4,533,846; 4,599,706; 4,617,652; 4,668,932; 4,752,912; 4,829, 482; 4,874, 967; 4,883, 976. Foreign patents and additional patents pending.

LIFE RELATED POLICY

In situations where semiconductor component failure may endanger life, system designers using this product should design the system with appropriate error detection and correction, redundancy and back-up features to prevent such an occurrence.

Xicor's products are not authorized for use in critical components in life support devices or systems.

1. Life support devices or systems are devices or systems which, (a) are intended for surgical implant into the body, or (b) support or sustain life, and whose failure to perform, when properly used in accordance with instructions for use provided in the labeling, can be reasonably expected to result in a significant injury to the user.
 2. A critical component is any component of a life support device or system whose failure to perform can be reasonably expected to cause the failure of the life support device or system, or to affect its safety or effectiveness.
-