



eZ80F920120MOD

eZ80F92 Ethernet Module

Product Specification

PS018606-0908



Warning: DO NOT USE IN LIFE SUPPORT

LIFE SUPPORT POLICY

ZILOG'S PRODUCTS ARE NOT AUTHORIZED FOR USE AS CRITICAL COMPONENTS IN LIFE SUPPORT DEVICES OR SYSTEMS WITHOUT THE EXPRESS PRIOR WRITTEN APPROVAL OF THE PRESIDENT AND GENERAL COUNSEL OF ZILOG CORPORATION.

As used herein

Life support devices or systems are devices which (a) are intended for surgical implant into the body, or (b) support or sustain life and whose failure to perform when properly used in accordance with instructions for use provided in the labeling can be reasonably expected to result in a significant injury to the user. A critical component is any component in a life support device or system whose failure to perform can be reasonably expected to cause the failure of the life support device or system or to affect its safety or effectiveness.

Document Disclaimer

©2008 by Zilog, Inc. All rights reserved. Information in this publication concerning the devices, applications, or technology described is intended to suggest possible uses and may be superseded. ZILOG, INC. DOES NOT ASSUME LIABILITY FOR OR PROVIDE A REPRESENTATION OF ACCURACY OF THE INFORMATION, DEVICES, OR TECHNOLOGY DESCRIBED IN THIS DOCUMENT. ZILOG ALSO DOES NOT ASSUME LIABILITY FOR INTELLECTUAL PROPERTY INFRINGEMENT RELATED IN ANY MANNER TO USE OF INFORMATION, DEVICES, OR TECHNOLOGY DESCRIBED HEREIN OR OTHERWISE. The information contained within this document has been verified according to the general principles of electrical and mechanical engineering.

eZ80 and eZ80Acclaim! are registered trademarks of Zilog, Inc. All other product or service names are the property of their respective owners.



**ISO 9001:2000
FS 507510**

Zilog products are designed and manufactured under an ISO registered 9001:2000 Quality Management System. For more details, please visit www.zilog.com/quality.

Revision History

Each instance in Revision History reflects a change to this document from its previous revision. For more details, refer to the corresponding pages and appropriate links in the table below.

Date	Revision Level	Description	Page Number
September 2008	06	Updated as per latest template and style guide changes.	All
December 2003	05	Fixed incorrect conditional indicators.	All
August 2003	04	Modified to remove zservice@zillog.com and other external hyperlinks to documentation.	All
February 2003	03	Fixed incorrect hyperlinks.	All
January 2003	02	Modified to reference eZ80Acclaim! [®] .	All

Table of Contents

Architectural Overview	1
eZ80F92 Ethernet Module Features	1
Module Bill of Materials	2
eZ80F92 Controller Features	4
Block Diagram	5
Pin Description	6
Peripheral Bus Connector	6
I/O Connector	10
Onboard Component Description	14
Logic-Level I/Os	14
Onboard Battery Backup	14
Ethernet Media Access Controller	14
Ethernet LEDs	14
Ethernet Connectors	15
GPIO Pins for Enabling LAN Activity, Sleep, Interrupt	15
EMAC Ports	16
EMAC Wait States	16
Memory	16
Wait States	16
Static RAM	16
IrDA Transceiver	17
Reset Generator	17
Serial Interface Ports	17
Physical Dimensions	18
Mounting the Module onto the eZ80 [®] Development Platform	21
ESD/EMI Protection	21
Absolute Maximum Ratings	22
Power Supply	23
Schematics	24
Customer Support	33

Architectural Overview

Zilog's eZ80F92 Ethernet Module is a compact, high-performance Ethernet module. It is specially designed for the rapid development and deployment of embedded systems requiring control and Internet/Intranet connectivity.

This expandable module is powered by Zilog's latest power-efficient, high-speed, optimized pipeline architecture eZ80F92 Microcontroller Unit (MCU)—eZ80F920020MOD, a member of Zilog's new line of eZ80Acclaim!® MCUs offering on-chip Flash memory.

The eZ80F92 MCU is a high-speed single-cycle instruction-fetch MCU, which can operate with a clock speed of 20 MHz. It can operate in Z80-compatible addressing mode (64 KB) or full 24-bit addressing mode (16 MB).

The rich peripheral set of the eZ80F92 Ethernet Module makes it suitable for a variety of applications, including industrial control, IrDA connectivity, communication, security, automation, point-of-sale (POS) terminals, and embedded networking applications.

► **Note:** *The eZ80F92 Ethernet Module incorporates the eZ80F92 MCU. The eZ80F92 can be replaced with the eZ80F93 MCU, which features 64KB of internal Flash memory and 4 KB of internal SRAM.*

eZ80F92 Ethernet Module Features

The key features of eZ80F92 Ethernet Module include:

- eZ80Acclaim!® Ethernet MCU with factory-default operating clock frequency at 20 MHz
- 10Base-T Ethernet Media Access Controller (MAC) + PHI with onboard RJ45 connector
- 512 KB zero-wait-state onboard SRAM
- 128 KB on-chip Flash memory
- 1 MB off-chip NOR Flash ROM (90 ns to 100 ns)
- GoldCap backup for Real-Time Clock (RTC)
- Input/Output (I/O) connector provides 24 general-purpose 5 V-tolerant I/O pinouts
- Zilog's industry-leading IrDA transceiver—Zilog's ZHX1810
- In-circuit Flash programming circuitry
- Onboard connector provides I²C 2-wire Serial Data Line (SDA)/Serial Clock Line (SCL) interface

- Onboard connector provides I/O bus for external peripheral connections (IRQ, \overline{CS} , 24 address, and 8 data)
- Low-cost adaptation to carrier board via two 2 x 25 pin (2.54 mm) headers
- Horizontal or vertical mounting onto the eZ80[®] Development Platform
- Small footprint 64 x 64 mm
- 3.3 V power supply
- Standard operating temperature range: 0 °C to +70 °C

Module Bill of Materials

Table 1 lists the installed components of the eZ80F92 Ethernet Module.

Table 1. Bill of Materials for the eZ80F92 Ethernet Module

Part Number	Part Name	Qty.	Jumper Location	Manufacturer
98C0873-001	FAB, eZ80F92/93 MODULE, Rev. A	1	—	Prime Technologies
35-0180-12	IC, SRAM, 512K x 8, 12 ns, 3 V, 36-SOJ	1	U1	Alliance Semi. AS7C34096-12JC
35-0016-05	IC, 74LVC04, 3.3 V, GATE, 14-SOIC	1	U2	Texas Instruments SN74LVC04AD
35-0720-10	IC, Flash, 1M x 8, 100 ns, 3 V, 40-TSSOP	1	U3	Micron Technologies MT28F008B3VG-10B
35-0719-00	IC, MAX6328, RESET, SOT-23	1	U4	Maxim Inc. MAX6328UR29-T
ZHX1810	IC, IR Transceiver, low profile	1	U5	Zilog Inc. ZHX1810MV115THTR
35-0062-01	IC, 74LCX32, LV, QUAD, or 14-TSSOP	1	U6	Fairchild Semi. 74LCX32MTC
35-0021-00	IC, CS8900A, ISA E-NET CNTL, 100 V QFP	1	U7	Cirrus Logic CS8900A-CQ3
EZ80F92	IC, eZ80F92AZ020SC, 20 MHZ, 100 V QFP	1	U8	Zilog Inc. EZ80F92AZ020SC
48-1013-01	DIODE, TVS ARRAY, XCVR PROT, 8-SOIC	1	U9	Semtec LCDA15C-6
17-2005-70	CAP, 1, 000 pF, 50V, ceramic chip, 0603	5	C3, C5, C21–23	Panasonic ECJ-1VC1H102J

Table 1. Bill of Materials for the eZ80F92 Ethernet Module (Continued)

Part Number	Part Name	Qty.	Jumper Location	Manufacturer
17-2005-66	CAP, 0.1 μ F, 16 V, ceramic chip, 0603	9	C4, C6–9, C13–15, C18	Kemet Inc. C0603C104K5RAC
17-2005-54	CAP, 0.01 μ F, 50V, ceramic chip, 0603	1	C10	Panasonic ECJ-1VB1C103K
17-2005-83	CAP, 0.33 μ F, 16 V, ceramic chip, 0603	1	C11	Panasonic ECJ-1VF1C334Z
17-2005-39	CAP, 560 pF, 50 V, ceramic chip, 0603	1	C12	Panasonic ECJ-1VC1H561J
17-2001-03	CAP, 12 pF, 50 V, ceramic chip, 0603	4	C16, C17, C20, C24	Panasonic ECJ-1VC1H120J
15-0100-01	CAP, 1.10 F, 5.5 V, GOLD, SD, COIN	1	C19	Panasonic EEC-SOHD104V
48-0030-04	Diode, Schottky, Power rectifier, SMT	1	D1	On Semiconductor MBR0520LT1
48-1004-02	Diode, LED, green/green, vertical, right angle	1	LD1	Chicago Miniature Lamp 5682F5;5
46-3001-03	Resistor, 10 k Ω , 1%, 1/16 W, 0603 SMT	9	R1, 11, 12, 17, 19, 29, 30, 34, 36	Sprague 420CK472X2PD
46-3000-00	Resistor, 0 Ω , 1%, 1/16W, 0603 SMT	2	R2, C25	"
46-3000-71	Resistor, 2.21 k Ω , 1%, 1/16W, 0603 SMT	3	R3, R10, R33	"
46-3000-35	Resistor, 68 Ω , 1%, 1/16W, 0603 SMT	1	R5	"
46-1005-03	Resistor, 2.7 Ω , 5%, 1/4W, 1206 SMT	1	R6	"
46-3001-03	Resistor, 4.75 k Ω , 1%, 1/16W, 0603 SMT	4	R7, 8, 13, 22	"
46-3000-27	Resistor, 33.2 Ω , 1%, 1/16W, 0603 SMT	1	R9	"
46-3000-39	Resistor, 100 Ω , 1%, 1/16W, 0603 SMT	5	R20, 21, 26, 28, 32	"
46-3000-80	Resistor, 4.99 k Ω , 1%, 1/16W, 0603 SMT	1	R23	"
46-3000-07	Resistor, 8.2 Ω , 1%, 1/16W, 0603 SMT	2	R24, R25	"
46-3001-51	Resistor, 1 M Ω , 1%, 1/16W, 0603 SMT	1	R27	"

Table 1. Bill of Materials for the eZ80F92 Ethernet Module (Continued)

Part Number	Part Name	Qty.	Jumper	
			Location	Manufacturer
47-0002-01	Resistor NTWK, 4.7 kΩ, Bus, 10-PSIP	1	RN1	"
23-0000-10	Internal crystal, 20.0000 MHz, SER/RESN, HC-49S	2	Y1, Y2	Fox Series HC-49S 20.0000 MHz
23-0006-00	Internal crystal, 32.768 kHz, SER/RESN, TF CASE	1	Y3	NDK MX-38
21-0907-00	Connector, RJ45, Fast jack, 10Base-T	1	J1	Halo Electronics HFJ11-1041E
21-0055-02	Connector, HDR/PIN, .025SQ, double row	2	JP1, JP2	"

eZ80F92 Controller Features

The key features of eZ80F92 include:

- The eZ80F92 device contains 128 KB of Flash memory and 8 KB of SRAM
- Single-cycle instruction fetch, high-performance, pipelined eZ80[®] CPU core
- Low power features including SLEEP mode, HALT mode, and selective peripheral power-down control
- Two Universal Asynchronous Receiver and Transmitters (UARTs) with independent baud rate generators and support for 9-bit operation
- Serial Peripheral Interface (SPI) with independent clock rate generator
- I²C with independent clock rate generator
- Infrared Data Association (IrDA)-compliant infrared encoder/decoder
- New Direct Memory Access (DMA)-like eZ80 CPU instructions for efficient block data transfer
- Glueless external memory interface with four chip selects, individual wait state generators, and an external WAIT input pin—supports Intel- and Motorola-style buses
- Fixed-priority vectored interrupts (both internal and external) and interrupt controller
- RTC with on-chip 32 kHz oscillator, selectable 50/60 Hz input, and separate V_{DD} pin for battery backup
- Six 16-bit Counter/Timers with prescalers and direct input/output drive
- Watchdog Timer (WDT)
- 24 bits of general-purpose input/output (GPIO)

- JTAG and ZDI debug interfaces
- 100-pin LQFP package
- 3.0 V to 3.6 V supply voltage with 5 V tolerant inputs
- Standard operating temperature range: 0 °C to +70 °C

► **Note:** All signals with an overline are active Low. For example, B/\overline{W} , for which WORD is active Low, and \overline{B}/W , for which BYTE is active Low.

Block Diagram

Figure 1 displays a block diagram of the eZ80F92 Ethernet Module.

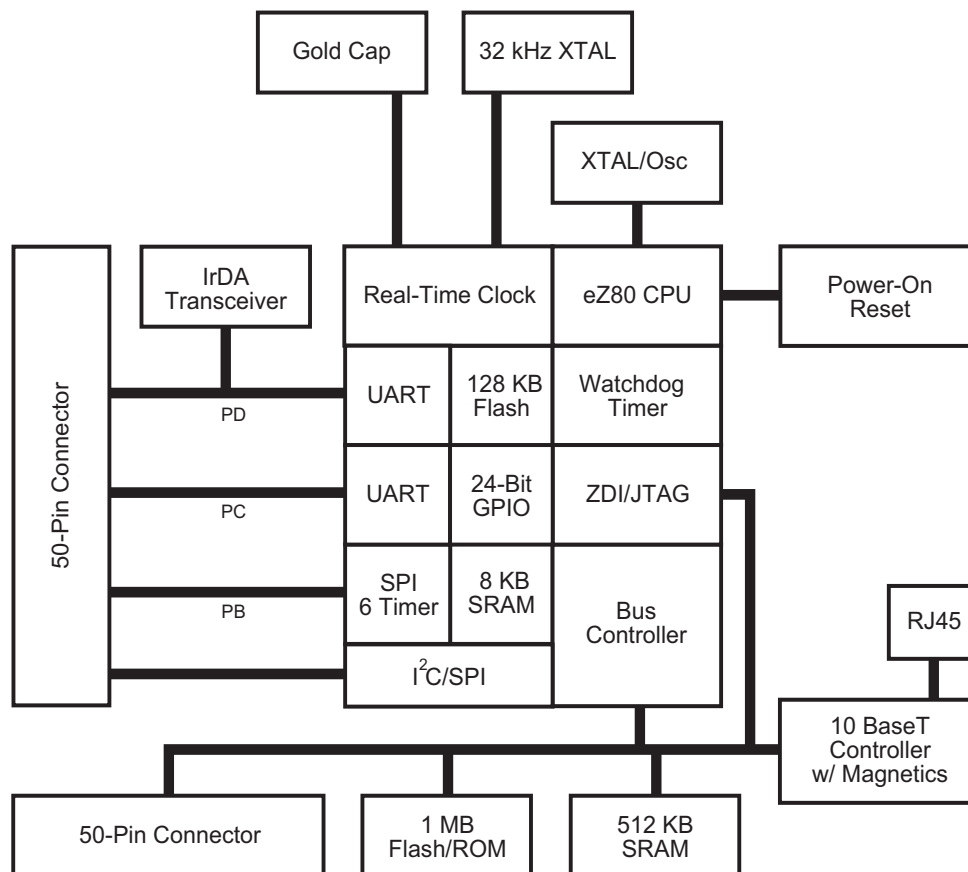

Figure 1. eZ80F92 Ethernet Module Functional Block Diagram

Pin Description

Peripheral Bus Connector

Figure 2 displays the pin layout of the eZ80F92 Ethernet Module’s I/O Connector (JP1) in the 50-pin package. Table 2 lists the pins and their functions.

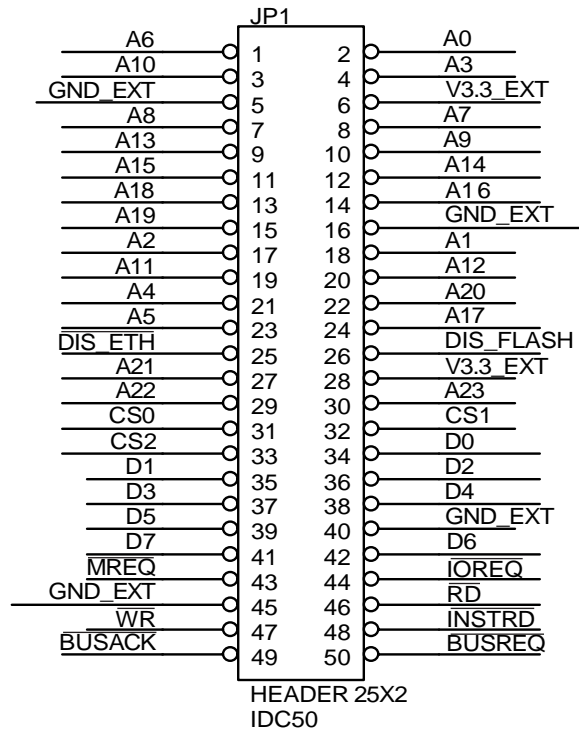

Figure 2. eZ80F92 Ethernet Module Peripheral Bus Connector Pin Configuration

Table 2. eZ80F92 Ethernet Module Peripheral Bus Connector Pin Identification*

Pin No.	Symbol	Pull Up/Down*	Signal Direction	Comments
1	A6		Bidirectional	
2	A0		Bidirectional	
3	A10		Bidirectional	
4	A3		Bidirectional	
5	GND			V _{SS} /Ground (0 V).
6	V _{DD}			3.3 V Supply Input Pin.
7	A8		Bidirectional	
8	A7		Bidirectional	
9	A13		Bidirectional	
10	A9		Bidirectional	
11	A15		Bidirectional	
12	A14		Bidirectional	
13	A18		Bidirectional	
14	A16		Bidirectional	
15	A19		Bidirectional	
16	GND			V _{SS} /Ground (0 V).
17	A2		Bidirectional	
18	A1		Bidirectional	
19	A11		Bidirectional	
20	A12		Bidirectional	
21	A4		Bidirectional	
22	A20		Bidirectional	
23	A5		Bidirectional	
24	A17		Bidirectional	

Table 2. eZ80F92 Ethernet Module Peripheral Bus Connector Pin Identification*

Pin No.	Symbol	Pull Up/Down*	Signal Direction	Comments
25	$\overline{\text{DIS_ETH}}$	PU 10 k Ω	Input	A Low disables onboard CS8900 EMAC responding to CS3. CS3 can be used off-board; CMOS Input 3.3 V (5 V tolerant). This pin is not used on the eZ80F92 Flash Module. However, it is connected to the pad of the CS8900 EMAC footprint.
26	$\overline{\text{DIS_FLASH}}$	PU 10 k Ω	Input	A Low disables onboard Flash to use external CS0 for memory. Flash is enabled if $\overline{\text{DIS_FLASH}}$ is not connected; CMOS Input 3.3 V (5 V tolerant). This pin is not used on the eZ80F92 Flash Module. However, it is connected to the pad of the external Flash footprint.
27	A21		Bidirectional	
28	V _{DD}			3.3 V supply input pin.
29	A22		Bidirectional	
30	A23		Bidirectional	
31	$\overline{\text{CS0}}$		Output	
32	$\overline{\text{CS1}}$		Output	
33	$\overline{\text{CS2}}$		Output	
34	D0	PU 4k7	Bidirectional	
35	D1	PU 4k7	Bidirectional	
36	D2	PU 4k7	Bidirectional	
37	D3	PU 4k7	Bidirectional	
38	D4	PU 4k7	Bidirectional	
39	D5	PU 4k7	Bidirectional	
40	GND			V _{SS} /Ground (0 V).
41	D7	PU 4k7	Bidirectional	
42	D6		Bidirectional	

Table 2. eZ80F92 Ethernet Module Peripheral Bus Connector Pin Identification*

Pin No.	Symbol	Pull Up/Down*	Signal Direction	Comments
43	$\overline{\text{MREQ}}$		Bidirectional	
44	$\overline{\text{IORQ}}$		Bidirectional	
45	GND			V_{SS} /Ground (0 V).
46	$\overline{\text{RD}}$		Bidirectional	
47	$\overline{\text{WR}}$		Bidirectional	
48	$\overline{\text{INSTRD}}$		Output	
49	$\overline{\text{BUSACK}}$		Output	
50	$\overline{\text{BUSREQ}}$	PU 2k2	Input	

* External capacitive loads on RD, WR, IORQ, MREQ, D0–D7, and A0–A23 should be below 10 pF to satisfy timing requirements for the CPU. All unused inputs should be pulled to either VDD or GND, depending on their inactive levels to reduce power consumption and to reduce noise sensitivity. To prevent EMI, the eZ80CLK output can be deactivated via software in the eZ80F92 peripheral power-down register. All inputs are CMOS level 3.3 V (5 V tolerant), except otherwise noted.

I/O Connector

Figure 3 displays the pin layout of the eZ80F92 Ethernet Module’s I/O Connector (JP2) in the 50-pin package. Table 3 lists the pins and their functions.

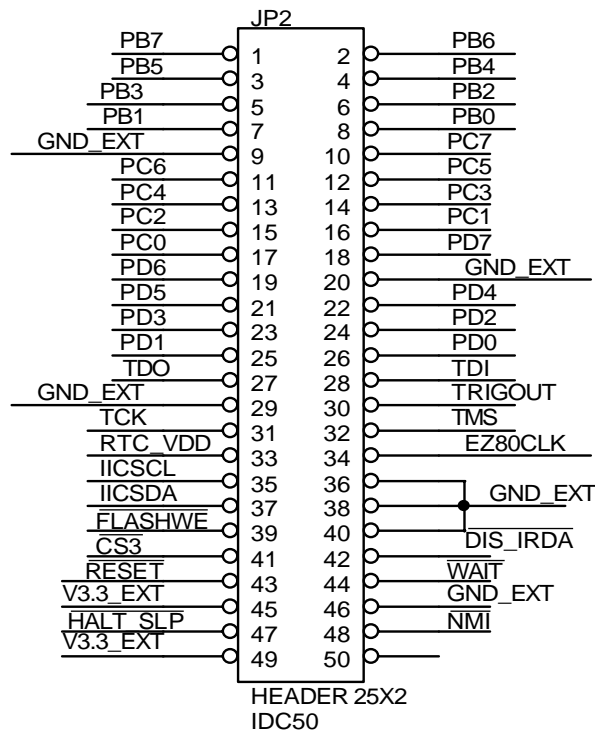

Figure 3. eZ80F92 Ethernet Module I/O Connector Pin Configuration

Table 3. eZ80F92 Ethernet Module I/O Connector Pin Identification*

Pin No.	Symbol	Pull Up/Down	Signal Direction	Comments
1	PB7		Bidirectional	
2	PB6		Bidirectional	
3	PB5		Bidirectional	
4	PB4		Bidirectional	
5	PB3		Bidirectional	
6	PB2		Bidirectional	

Table 3. eZ80F92 Ethernet Module I/O Connector Pin Identification* (Continued)

Pin No.	Symbol	Pull Up/Down	Signal Direction	Comments
7	PB1		Bidirectional	
8	PB0		Bidirectional	
9	GND			V _{SS} /Ground (0V).
10	PC7		Bidirectional	
11	PC6		Bidirectional	
12	PC5		Bidirectional	
13	PC4		Bidirectional	
14	PC3		Bidirectional	
15	PC2		Bidirectional	
16	PC1		Bidirectional	
17	PC0		Bidirectional	
18	PD7		Bidirectional	
19	PD6		Bidirectional	
20	GND			V _{SS} /Ground (0V).
21	PD5		Bidirectional	
22	PD4	PD 4k7	Bidirectional	
	ETHIRQ	PD 4k7	NC	
23	PD3		Bidirectional	
24	PD2		Bidirectional	
25	PD1		Bidirectional	
26	PD0		Bidirectional	
27	TDO		Output	JTAG Data Output pin.
28	TDI/ZDA		Input	JTAG Data Input pin.
	ZDA		Bidirectional	ZDI Data I/O.
29	GND			V _{SS} /Ground (0V).
30	TRIGOUT		Output Input/ Output (Test)	Active High trigger event indicator. Input mode only when configured as the TEST mode input pin.
31	TCK	PU 10 kΩ	Input	JTAG Input. High on reset enables ZDI mode; Low on reset enables OCI debug.

Table 3. eZ80F92 Ethernet Module I/O Connector Pin Identification* (Continued)

Pin No.	Symbol	Pull Up/Down	Signal Direction	Comments
32	TMS	PU 10 kΩ	Input	JTAG TEST Mode Select Input.
33	RTC_V _{DD}			RTC supply from GoldCap (or external battery).
34	EZ80CLK		Output	20 MHz synchronous CPU clock output.
35	SCL	PU 4k7	Bidirectional	I ² C Bus Clock.
36	GND			V _{SS} /Ground (0 V).
37	SDA	PU 4k7	Bidirectional	I ² C Data Clock.
38	GND			V _{SS} /Ground (0V).
39	FLASHWE	PU 10 kΩ	Input	Low enables WRITE to external Flash memory boot block area. If this pin is unconnected, the Flash memory boot block area is write-protected. This pin has no function on the eZ80F92 Flash Module. It is pulled up to V _{DD} and a connection is available on the external Flash memory pads.
40	GND			V _{SS} /Ground (0V).
41	CS3		Output	Used on eZ80F92 Flash Module and connected to the CS8900 EMAC device. Chip select for onboard or external devices; CMOS output 3.3 V.
42	$\overline{\text{DIS_IRDA}}$	PU 10 kΩ	Input	Low disables onboard IRDA transceiver to use PD0/PD1 UART pins externally.
43	$\overline{\text{RESET}}$	PU 2k2	Bidirectional	Reset Output from module or push-button reset.
44	$\overline{\text{WAIT}}$	PU 2k2	Input	Driving the $\overline{\text{WAIT}}$ pin Low forces the CPU to provide additional clock cycles for an external peripheral or external memory to complete its Read or Write operation.
45	V _{DD}			3.3 V supply input pin.
46	GND			V _{SS} /Ground (0V).
47	$\overline{\text{HALT_SLP}}$		Output, Active Low	A Low on this pin indicates that the CPU enters either HALT or SLEEP mode because of execution of either a HALT or SLP instruction.

Table 3. eZ80F92 Ethernet Module I/O Connector Pin Identification* (Continued)

Pin No.	Symbol	Pull Up/Down	Signal Direction	Comments
48	$\overline{\text{NMI}}$	PU 10 k Ω	Schmitt Trigger Input, Active Low	The $\overline{\text{NMI}}$ input is a higher priority input than the maskable interrupts. It is always recognized at the end of an instruction, regardless of the state of the interrupt enable control bits. This input includes a Schmitt trigger to allow RC rise times. This external $\overline{\text{NMI}}$ signal is combined with an internal $\overline{\text{NMI}}$ signal generated from the $\overline{\text{WDT}}$ block before being connected to the $\overline{\text{NMI}}$ input of the CPU.
49	V_{DD}			3.3 V supply input pin.
50	Reserved			

* External capacitive loads on $\overline{\text{RD}}$, $\overline{\text{WR}}$, $\overline{\text{IORQ}}$, $\overline{\text{MREQ}}$, D0–D7, and A0–A23 should be below 10 pF to satisfy timing requirements for the CPU. All unused inputs should be pulled to either V_{DD} or GND, depending on their inactive levels, to reduce power consumption and to reduce noise sensitivity. To prevent EMI, the eZ80CLK output can be deactivated via software in the eZ80F91 peripheral power-down register. All inputs are CMOS level 3.3 V (5 V tolerant), except where otherwise noted.

Onboard Component Description

Logic-Level I/Os

The I/O connector features 24 general-purpose 3.3 V CMOS I/O pins that can be used as outputs or inputs interfacing to external logic. All I/Os are 5 V tolerant. Some of the GPIO pins support dual mode functions (SPI, Timer I/O, UARTs, and bit I/O with edge- or level-triggered interrupt functions on each pin). For more information on eZ80F92 dual modes, refer to *eZ80F92/eZ80F93 Product Specification (PS0153)*.

Onboard Battery Backup

An onboard 0.1 F capacitor (GoldCap) is used to bridge power outages of 2–4 hours if the power supply to the module is disconnected. The capacitor is charged to 3.1 V during normal operation and is discharged through the on-chip RTC. The V_{RTC} pin is available on the I/O connector of the module to connect external components to a power supply or to a larger GoldCap.



Caution: *Do not connect a Lithium Battery to the GoldCap capacitor, because onboard charging circuitry for the capacitor can destroy the lithium battery.*

Ethernet Media Access Controller

The eZ80F92 Flash Module contains a CS8900A EMAC (MAC, PHI, and RAM), which is attached to the data/address bus of the processor. This chip is connected to the processor's CS3 Chip Select, A0–A3, D0–D7, \overline{RD} , \overline{WR} , and PD4 pins for interrupt purposes. Connection of pins PD6 and PD7 for LANACT (wake-up from sleep) and SLEEP is optional and resistor-selectable onboard.

Ethernet LEDs

There are two green LEDs, a Link LED and a LAN LED, that are located adjacent to each other on the eZ80F92 Flash Module. A flashing LAN LED (top) indicates received link pulses from the 10Base-T Ethernet. This LAN LED should be ON if RX+ is connected to TX+, and RX– is connected to TX–. A steady Link LED (bottom) indicates Traffic (RX or TX) on the LAN.

An RJ45 loopback connector can be used to verify the correct operation of the Receiver and the Transmitter. The green LED should be ON if RX+ is connected with TX+, and RX– is connected with TX–.

Ethernet Connectors

The eZ80F92 Flash Module is equipped with an RJ45 connector that features integrated magnetics (transformer, common mode chokes). The remaining pins onboard of RJ45 connector are not connected.

Table 4 lists the node assignments for the RJ45 Ethernet connector.

Table 4. Ethernet Connector Pin Assignments

Pin	Function
1	TX+
2	TX-
3	RX+
6	RX-

Node assignment, in contrast to hub assignment, means that a straight-through cable (equivalent pin numbers on both sides of the cable are connected to each other) is used to attach the board to an Ethernet hub or switch. To connect the eZ80F92 Flash Module directly to another node (for example, a personal computer), a crossover cable must be used.

The EMAC can be protected by placing a U9 ESD protection array on the module. This array can be either of the LCDA15C-6 (Semtech) or ESDA25B1 (ST Microelectronics) devices.

GPIO Pins for Enabling LAN Activity, Sleep, Interrupt

GPIO input bit PD4 serves as an active High interrupt input for the EMAC's INTRQ0 output.

GPIO output bit PD7 can be used to enter the EMAC into SLEEP mode. When pulling SLEEP (PD7) Low after enabling HWStandbyE and HWSleepE modes, the chip draws lower current, because only the receiver is operating. A zero-ohm resistor at position R14 on the eZ80F92 Flash Module is required for this function. In this case, the PD6 pin is not available for GPIO on the I/O connector.

If LAN activity is detected, the LANACT signal is pulled Low. The LANACT is connected to GPIO input PD6 and can be used in interrupt edge-detection mode to wake up and reinitialize the Ethernet chip. A zero-ohm resistor at position R15 on the module is required for this function. In this case, the PD6 pin is not available for GPIO on the I/O connector.

EMAC Ports

Chip Select CS3 is used for selecting the EMAC via I/O decoding. The I/O base address is user-selectable. The EMAC is connected as an 8- or 16-bit device with 8-word-wide I/O registers.

EMAC Wait States

The CS8900A EMAC should be operated in Intel bus mode so that the setup and hold times for the I/O access are met. For 20 MHz operation, first set CS3_BMC (I/O address 0xF3h) to 84h (Intel bus mode with four system clock cycles per bus cycle) and then CS3_CTL (I/O Address 0xB3) to 18h (0 wait states for I/O). For a 20.8 ns CPU Clock cycle time, the READ and WRITE access time is:

$$(2 \times 4 \times 20.8) \text{ ns} - 16 \text{ ns (for capacitive and chip delays)} = 150 \text{ ns}$$

Memory

The eZ80F92 Ethernet Module offers SRAM and Flash memories and the wait states selectable in the eZ80F92 MCU's support memory operations, as described in this section.

Wait States

To ensure that valid data is read from or written to slower memories, a number of wait states must be inserted into the memory or I/O access operations by the controller. The number of wait states that are required should be added by programming the chip select control registers. To calculate the minimum number of wait states required, see [Table 5](#).

Table 5. Chip Frequency to Wait State Cycle Time Calculation

MHz	Cycle Time
12	83.3 ns
20	50.0 ns

Static RAM

The eZ80F92 Ethernet Module features 512 KB of fast SRAM. Access speed is typically 50 ns, allowing zero-wait-state operation at 20 MHz. With the CPU at 20 MHz, SRAM can be accessed with zero wait states in eZ80[®] mode. CS1_CTL (chip select CS1) can be set to 08h (no wait states).

IrDA Transceiver

An onboard IrDA transceiver (Zilog ZHX1810) is connected to PD0 (TX), PD1 (RX), and PD2 (Shutdown, R_SD). The IrDA transceiver is of the LED type 870 nm Class 1.

The receiver supply current is 90–150 μ A and the transmitter supply current is 260 mA when the LED is active. The IrDA transceiver is accessible via the IrDA controller attached to UART0 on the eZ80F92 device. The UART0 console and the IrDA transceiver cannot be used simultaneously.

To use the UART0 for console or to save power, the transceiver can be disabled by the software or by an off-board signal when using the proper jumper selection. The transceiver is disabled by setting PD2 (IR_SD) High or by pulling the DIS_IRDA pin on the I/O connector Low. The shutdown is used for power savings. To enable the IrDA transceiver, DIS_IRDA is left floating and PD2 is set to Low.

Reset Generator

The onboard Reset Generator Chip performs reliable Power-On Reset (POR). The chip generates a Reset pulse with a duration of 200 ms if the power supply drops below 2.93 V. This reset pulse ensures that the board always starts in a defined condition. The RESET pin on the I/O connector reflects the status of the Reset line. It is a bidirectional pin for resetting external peripheral components or for resetting the eZ80F92 Ethernet Module with a low-impedance output (for example, a 100 Ω push-button).

Serial Interface Ports

The controller contains two 16550-style UARTs with programmable baud rate generators. UART0 is typically used for console I/O and initial boot code upload or to connect remote peripherals that can be controlled and monitored via Ethernet. UART0 is connected to GPIO PD[0:3] on the I/O connector. There are no RS-232 level shifters on the eZ80F92 Ethernet Module.

► **Note:** *Do not connect an RS-232 interface without level shifters.*

UART1 can be used for modem attachment or as a communications port to a host computer, where the embedded Ethernet module emulates an AT-style modem for internet access. UART1 does not offer onboard RS-232 level shifters.

Physical Dimensions

The size of eZ80F92 Ethernet Module PCB is 64x64 mm. With an RJ45 Ethernet connector; the overall height is 25 mm as displayed in Figure 4.

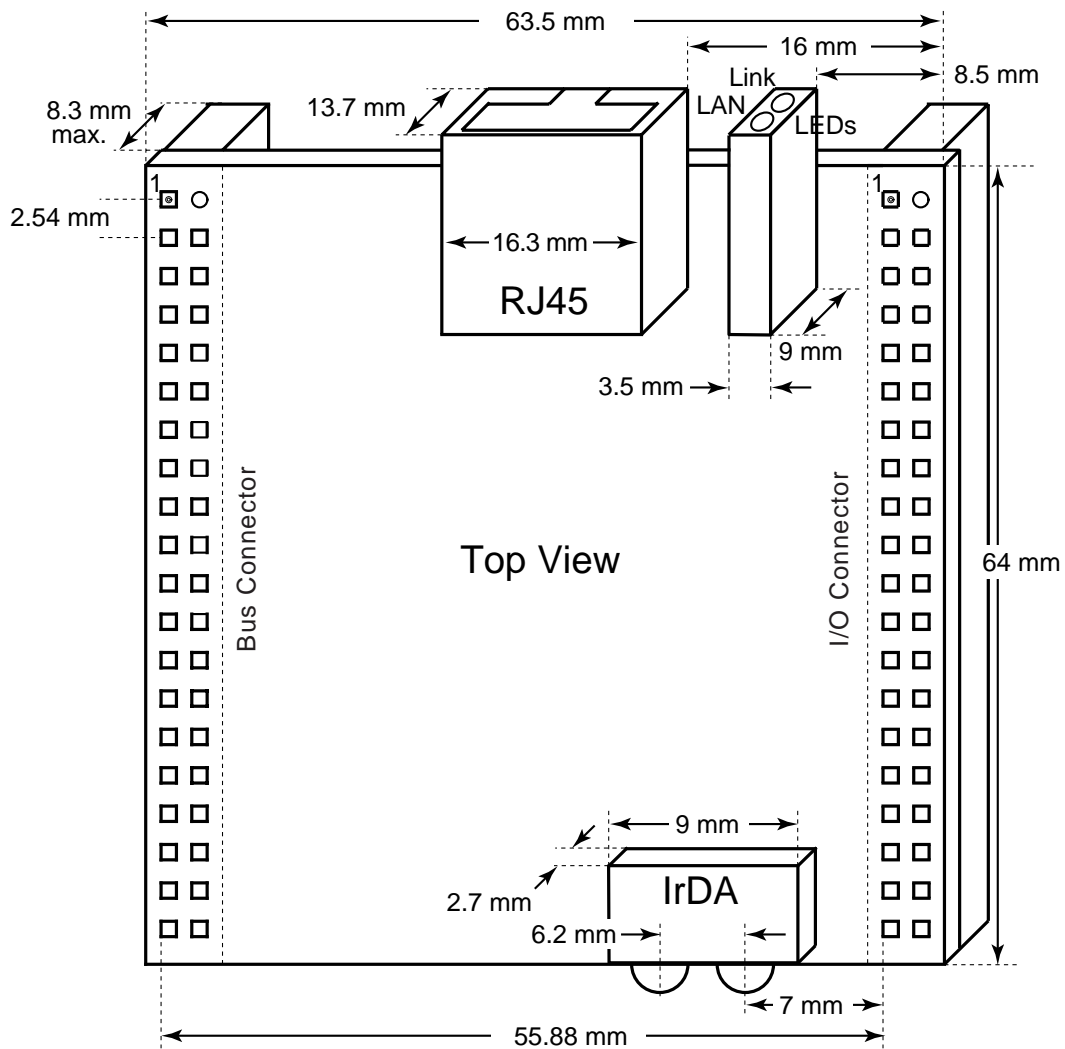

Figure 4. Dimension Drawing

Figure 6 displays a bottom view of the eZ80F92 Ethernet Module.

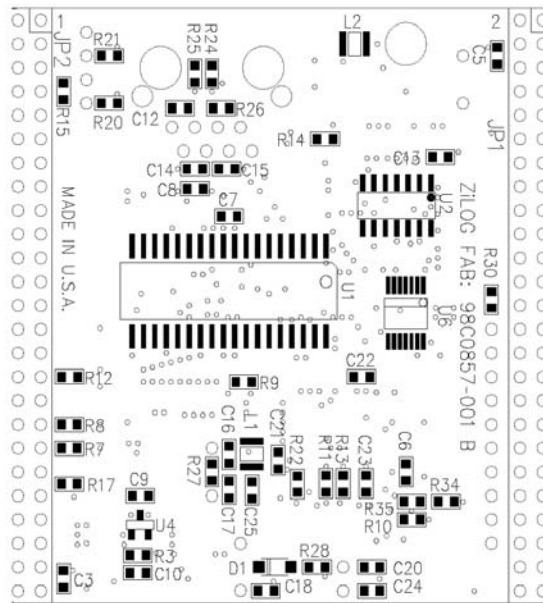

Figure 6. Bottom Layer

Mounting the Module onto the eZ80® Development Platform

The eZ80F92 Ethernet Module can be mounted in several positions. Depending on volume and area restrictions, it can be mounted horizontally or vertically with or without components between the connectors on the eZ80 Development Platform. See [Figure 7](#) for examples.

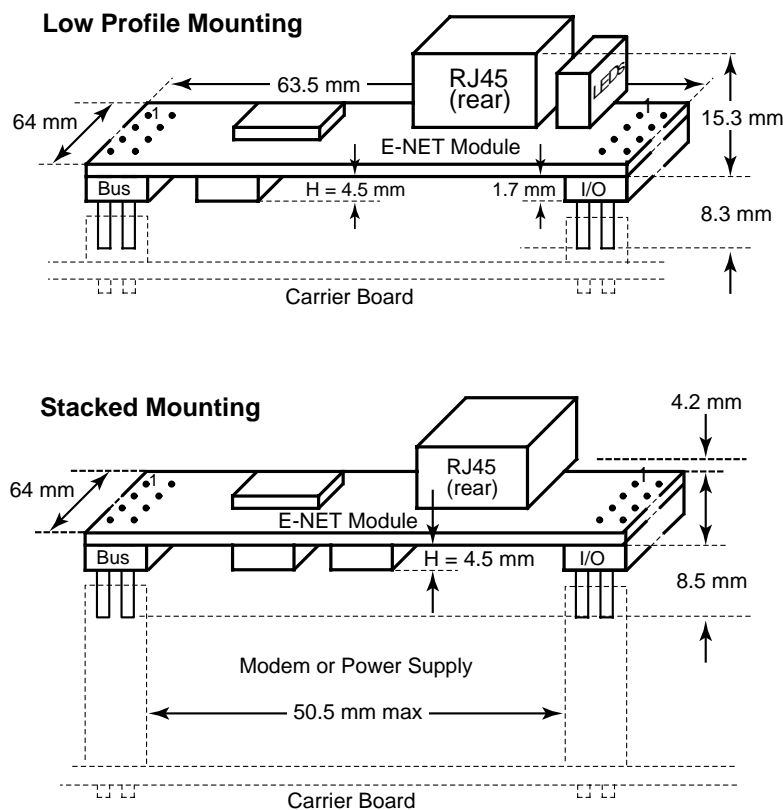

Figure 7. Mounting Examples

ESD/EMI Protection



Caution: The eZ80F92 Ethernet Module is a component that is intended to be part of a system design for end-user devices. Take precaution to use ESD protection on the I/O pins.

The EMAC can also be protected by placing an ESD protection array on the eZ80F92 Ethernet Module at position U9. Either use ESDA25B1 from ST Microelectronics or LCDA15C-6 from Semtech. A mounting hole on the board can be used for grounding the

shield of the Ethernet RJ45 jack to prevent surge or ESD currents from flowing through the digital circuitry.

The RJ45 Ethernet Connector on the eZ80F92 Ethernet Module contains a transformer and common mode chokes for EMI suppression.



Caution: *CMOS I/Os are ESD-sensitive and must be handled with care. Handling of the module should be performed in ESD-safe environments (for example with a wrist-wrap attached). When developing applications, you must provide, for proper ESD protection on external, user-accessible I/Os (for example, suppressor arrays for the I/Os).*

The components are mounted on a multilayer PCB to provide a stable ground plane for onboard components. The module features several GND pins next to pins with higher switching frequency for short ground returns. If unused, the clock output can be separated from the module header by removing a series resistor on the module. Removing the series resistor further reduces electromagnetic emissions.

Absolute Maximum Ratings

Stresses greater than those listed in [Table 6](#) can cause permanent damage to the device. These ratings are stress ratings only. Operation of the device at any condition outside those indicated in the operational sections of these specifications is not implied. Exposure to absolute maximum rating conditions for extended periods may affect device reliability. For improved reliability, unused inputs should be tied to one of the supply voltages (V_{DD} or V_{SS}).

Table 6. Absolute Maximum Ratings

Parameter	Min	Max	Units
Standard operating temperature	0	+70	°C
Storage temperature	-45	+85	°C
Operating humidity (RH @ 50 °C)	25%	90%	
Operating voltage ($\pm 5\%$)	—	3.3	V

Power Supply

The eZ80F92 Ethernet Module requires a regulated external 3.3 V DC/0.5 A power supply. You may use a Low Dropout Regulator (LDO) to get 3.3 V from 5 V or use the following switcher circuit to generate 3.3 V from unregulated 10 V to 28 V power supply.

Power connections follow these conventional descriptions:

Connection	Circuit	Device
Power	V _{CC}	V _{DD}
Ground	GND	V _{SS}

Figure 8 displays two typical power supply examples.

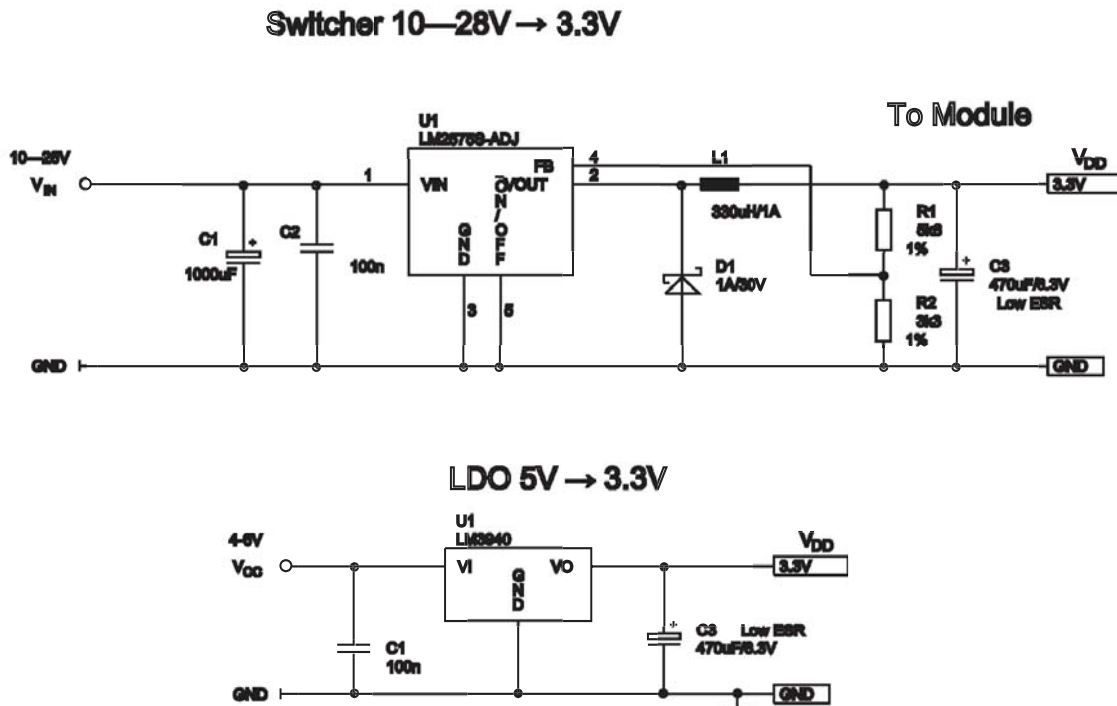

Figure 8. Power Supply Examples

Schematics

Figure 9 through Figure 17 on page 32 displays the layout of the eZ80F92 Ethernet Module.

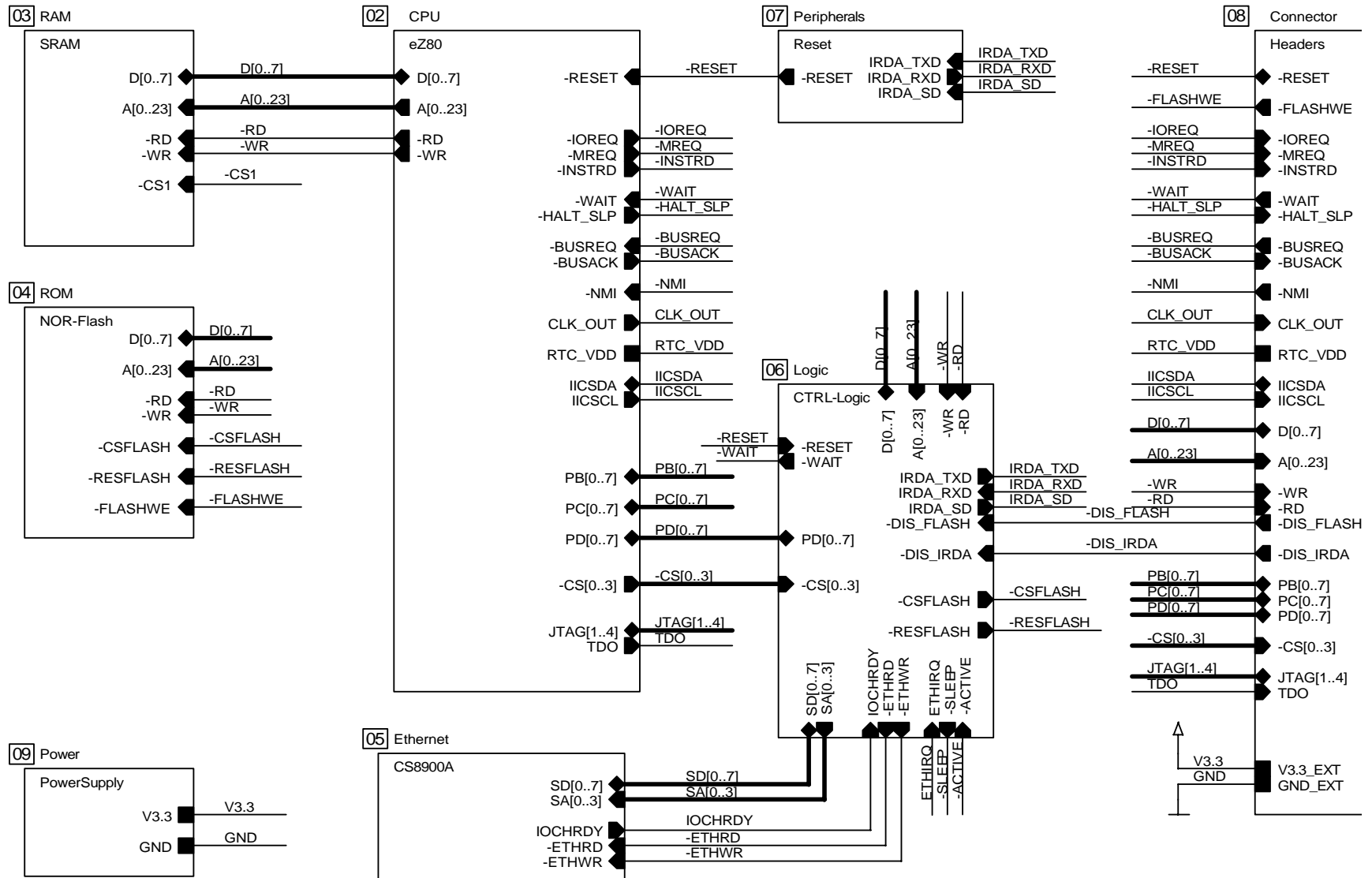

Figure 9. eZ80F92 Ethernet Module Schematic Diagram, #1 of 9—Top Level

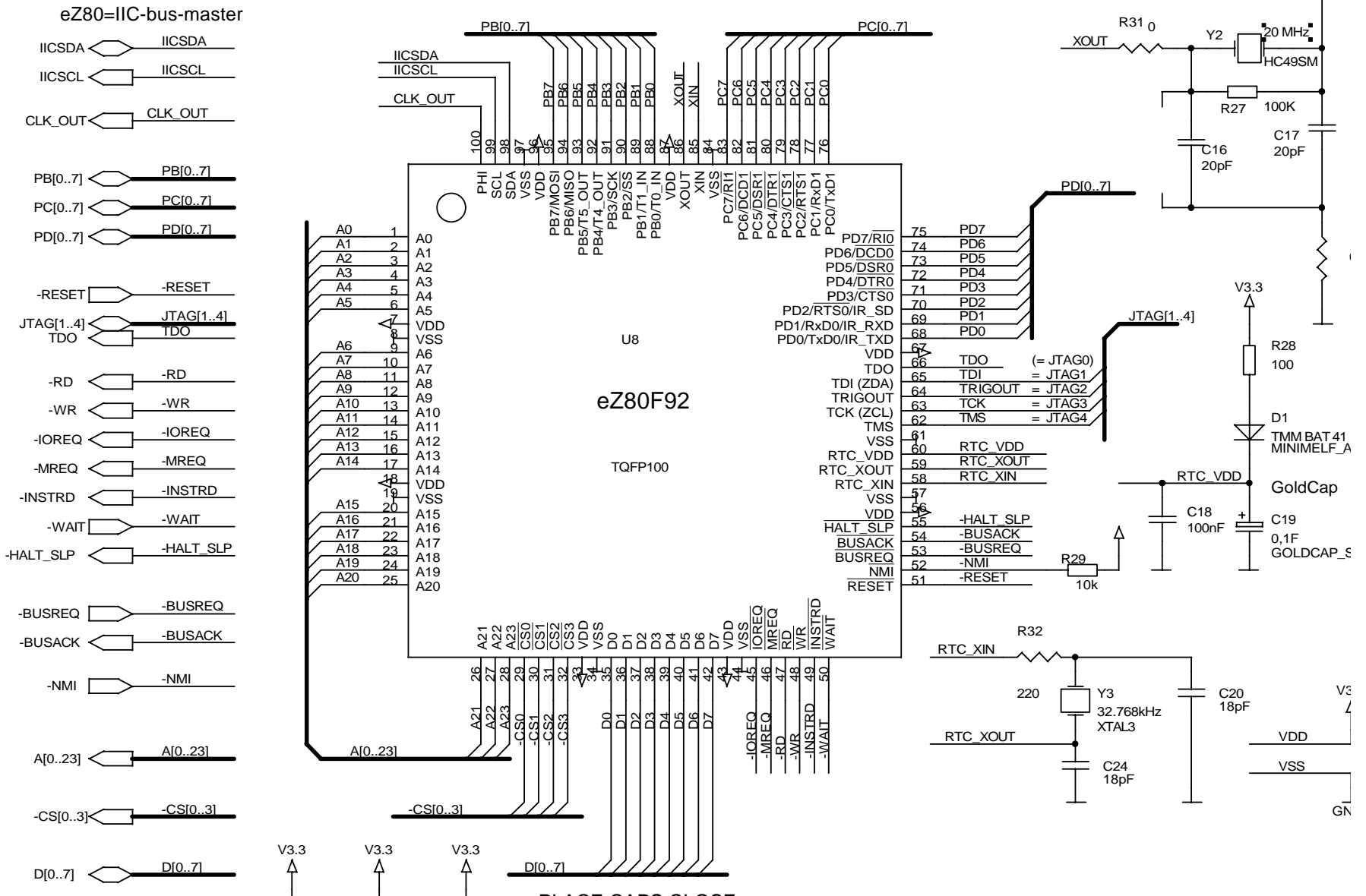
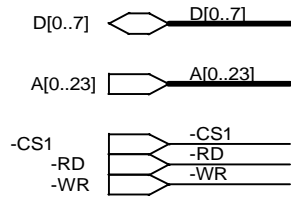

Figure 10. eZ80F92 Ethernet Module Schematic Diagram, #2 of 9—100-Pin QFP eZ80F92 Device



A19/A20/A21/A22/A23
not used here

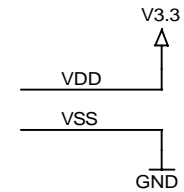
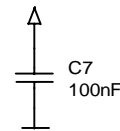
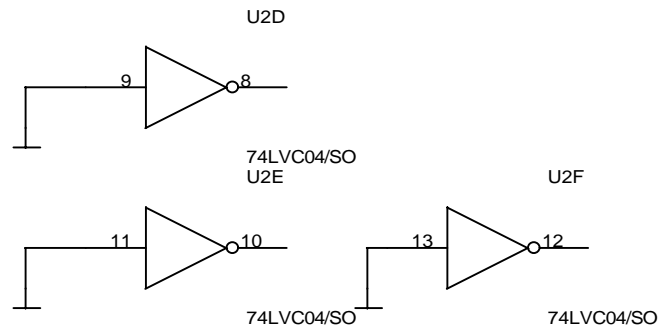
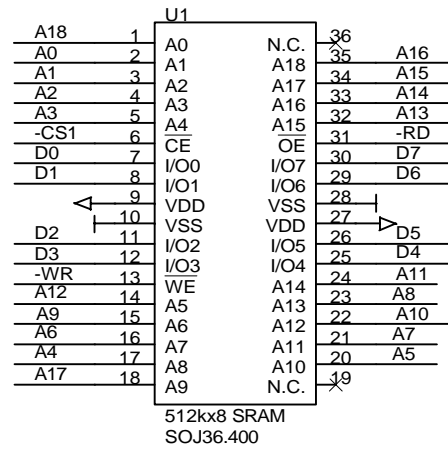
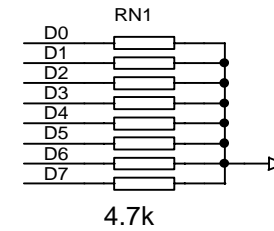

Figure 11. eZ80F92 Ethernet Module Schematic Diagram, #3 of 9—36-Pin SRAM Device

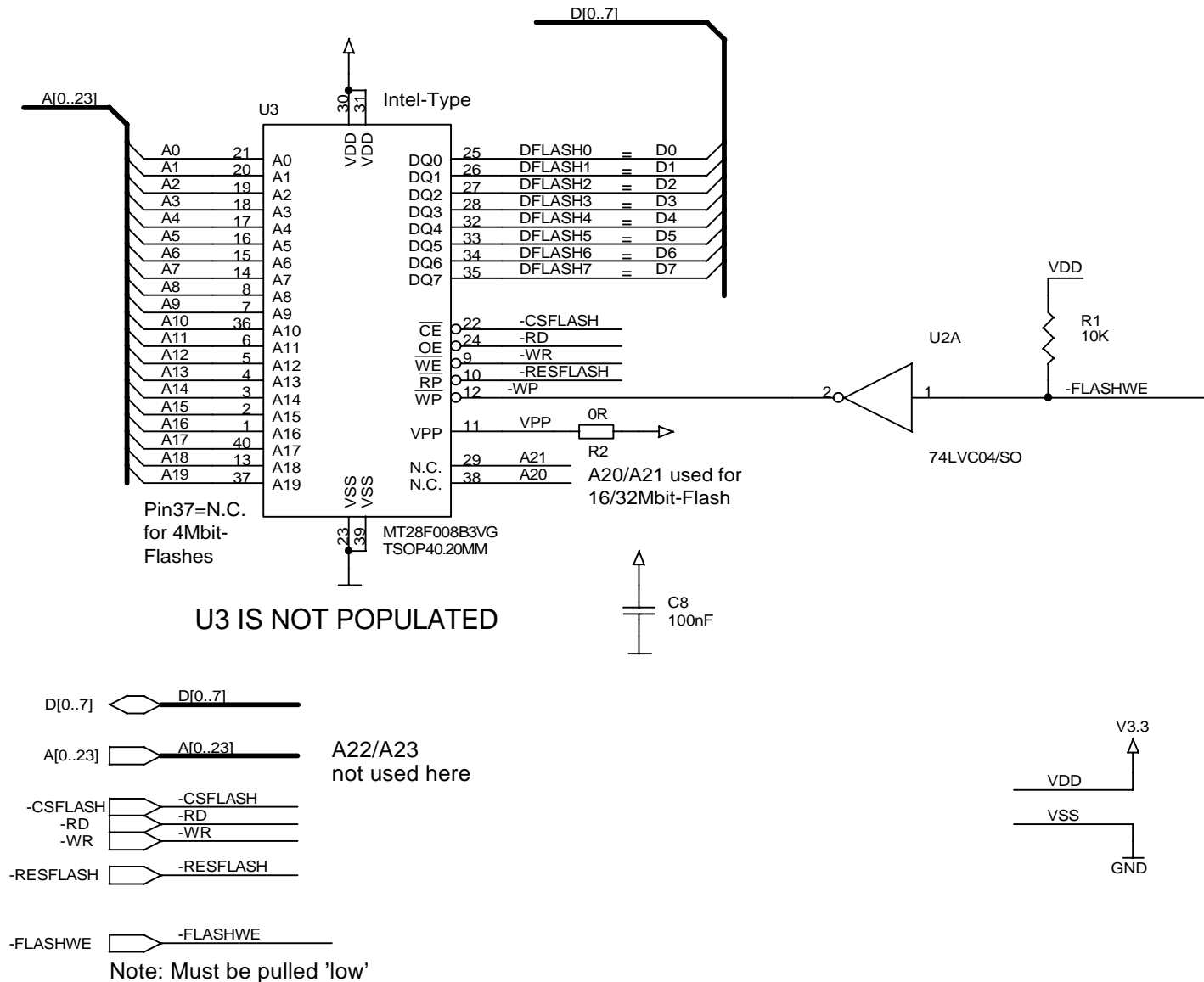

Figure 12. eZ80F92 Ethernet Module Schematic Diagram, #4 of 9—NOR Flash Device

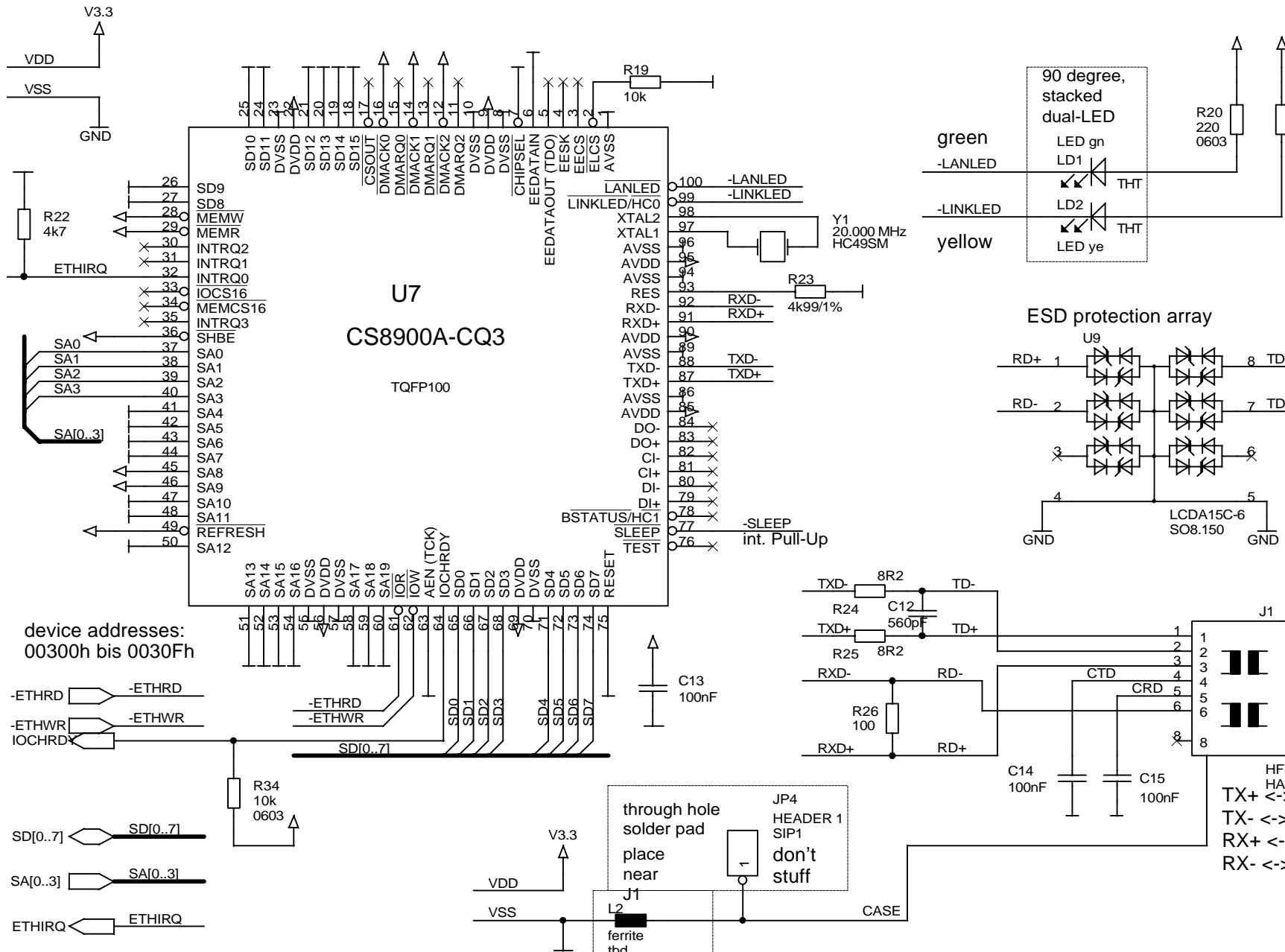
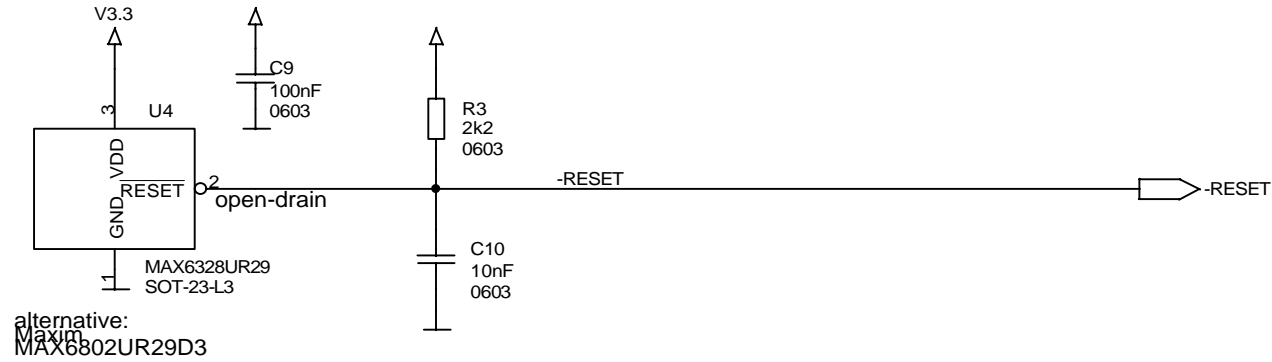

Figure 13. eZ80F92 Ethernet Module Schematic Diagram, #5 of 9—Module

power supervisor



IR-transceiver

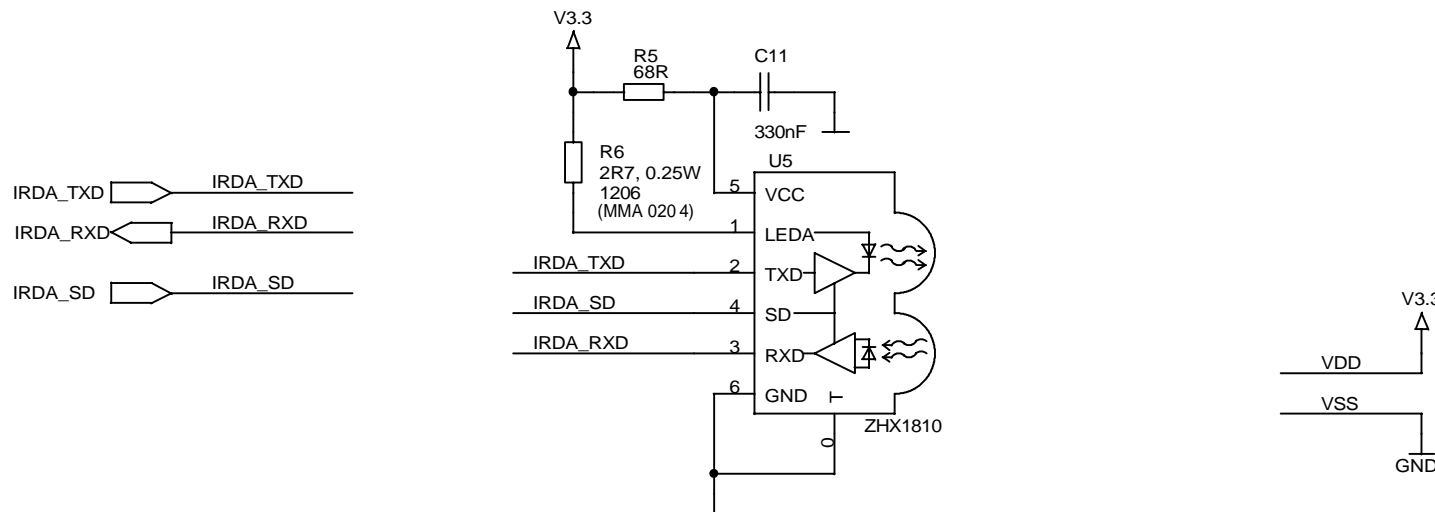

Figure 14. eZ80F92 Ethernet Module Schematic Diagram, #6 of 9—IrDA Reset

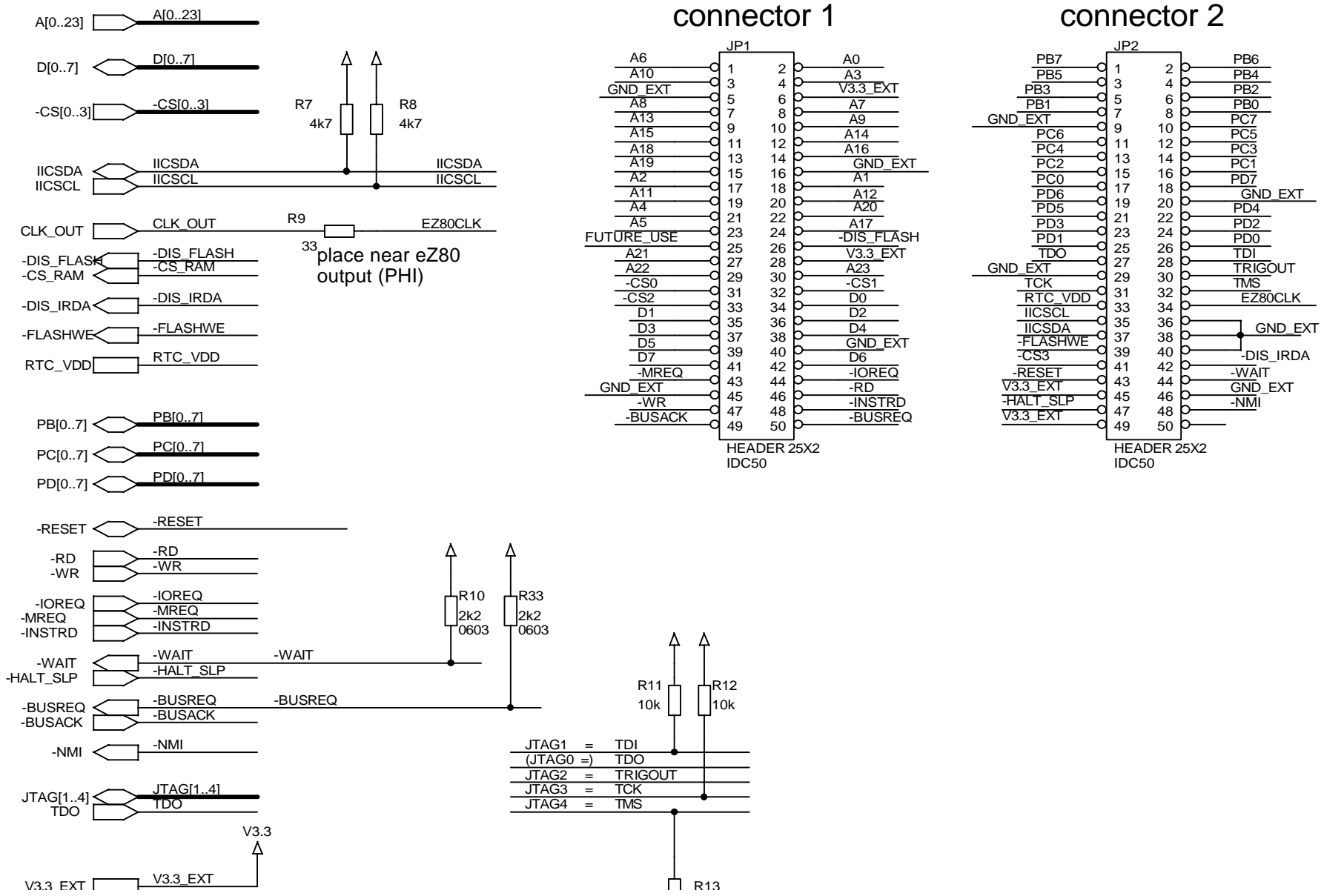
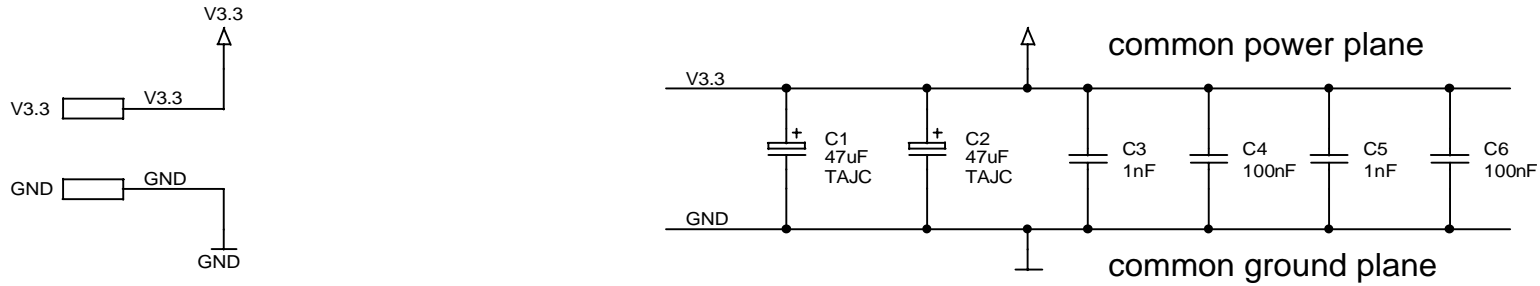

Figure 15. eZ80F92 Ethernet Module Schematic Diagram, #7 of 9—Headers



no power supply on board!

Input: $V_{DD}(=V3.3) = 3.3V -5\%$

Power: $P_{max} = 1.6W$
 $P_{typ} = 0.4W$

Current: $I_{max} = 200mA$ (IrDA not in use)
 $I_{max} = 460mA$ (IrDA in use)
 $I_{typ} = 100mA$

PCB1
E-NET Module Rev.B
98Cxxx-xxx

for test purposes

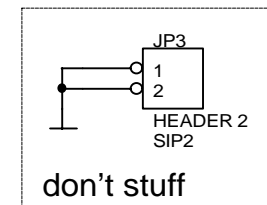

Figure 16. eZ80F92 Ethernet Module Schematic Diagram, #8 of 9—Power Supply

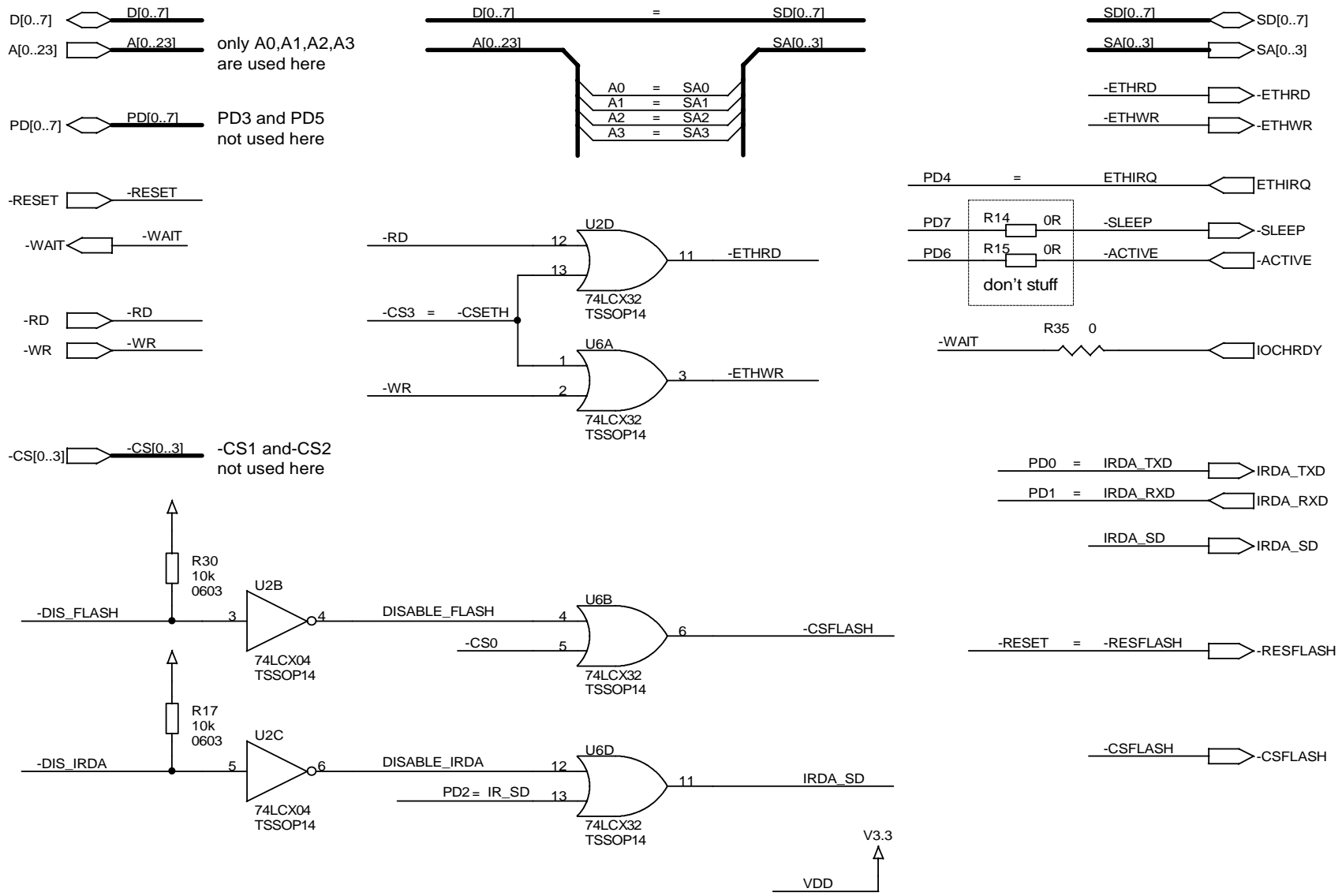

Figure 17. eZ80F92 Ethernet Module Schematic Diagram, #9 of 9—Control Logic

Customer Support

For answers to technical questions about the product, documentation, or any other issues with Zilog's offerings, please visit Zilog's Knowledge Base at <http://www.zilog.com/kb>.

For any comments, detail technical questions, or reporting problems, please visit Zilog's Technical Support at <http://support.zilog.com>.