



COMPONENT DISTRIBUTORS, INC.
Since 1970
www.cdiweb.com

Distributing Tomorrow's Technologies For Today's Designs
Toll-Free: 1-800-777-7334

ZMDI[®]
The Analog Mixed Signal Company

Kit Description

Rev. 1.0 / December 2010

ZLED7012

ZLED7012KIT-E1 Evaluation Kit



Component Distributors Inc. (CDI)

Toll-Free: 1-800-777-7334 • E-Mail: sales@cdiweb.com

Web: www.cdiweb.com

ZLED7012
 ZLED7012KIT-E1 Evaluation Kit



Important Notice

Restrictions in Use

ZMDI's ZLED7012KIT-E1 Evaluation Kit hardware and software are designed for ZLED7012 evaluation, laboratory setup, and module development only. The ZLED7012KIT-E1 Evaluation Kit hardware and software must not be used for module production or production test setups.

Disclaimer

Zentrum Mikroelektronik Dresden AG (ZMD AG) shall not be liable for any damages arising out of defects resulting from

- (i) delivered hard- and software
- (ii) non-observance of instructions contained in this manual and in any other documentation provided to user, or
- (iii) misuse, abuse, use under abnormal conditions or alteration by anyone other than ZMD AG.

To the extent permitted by law, ZMD AG hereby expressly disclaims and user expressly waives any and all warranties, whether express, implied or statutory, including, without limitation, implied warranties of merchantability and of fitness for a particular purpose, statutory warranty of non-infringement and any other warranty that may arise by reason of usage of trade, custom or course of dealing.

Contents

1	Kit Contents	3
2	Kit Description	3
2.1.	Overview	3
2.2.	Power Supply	3
2.3.	Interface and Setting Options	4
2.4.	Demo Mode	5
2.5.	Manual Mode	5
2.6.	Schematic Diagram	6
3	Ordering Information	7
4	Related Documents	7
5	Glossary	7
6	Document Revision History	7

List of Figures

Figure 2.1	ZLED7012KIT-E1 Evaluation Board (Top View)	4
Figure 2.2	ZLED7012KIT-E1 Schematic Diagram	6

List of Tables

Table 2.1	Current Output Settings	5
-----------	-------------------------------	---

Evaluation Kit December 8, 2010	© 2010 Zentrum Mikroelektronik Dresden AG — Rev. 1.0 All rights reserved. The material contained herein may not be reproduced, adapted, merged, translated, stored, or used without the prior written consent of the copyright owner. The information furnished in this publication is subject to changes without notice.	2 of 7
------------------------------------	--	--------

ZLED7012

ZLED7012KIT-E1 Evaluation Kit

The Analog Mixed Signal Company



1 Kit Contents

The ZLED7012KIT-E1 Evaluation Kit consists of the following parts:

- ZLED7012-E1 Evaluation Board VX.x
- USB cable male A / male Mini-B
- Five ZLED7012 samples, UTQFN package (2mm×2mm)
- *ZLED7012KIT-E1 Evaluation Kit Start-up Information*
- *Kit Disclaimer*

The ZLED7012KIT-E1 Evaluation Kit is fully assembled and ready for immediate operation.

2 Kit Description

2.1. Overview

The ZLED7012KIT-E1 Evaluation Kit provides a quick and easy method for evaluating the ZLED7012 within its basic application circuit. An on-board generator demonstrates the ZLED7012's Pulse Count Control (PCC) digital brightness control feature. Reading the *ZLED7012 Data Sheet* before using the Evaluation Kit is recommended for understanding the operation of the ZLED7012 and the Evaluation Board.

The ZLED7012 is a low-noise, constant-frequency charge pump DC/DC converter that can drive up to four LED channels, providing a programmable constant current level ranging from 1.8mA to 20mA per LED channel. The ZLED7012's current sinks can operate in parallel for driving higher current LEDs as well. The ZLED7012's low dropout current sinks are capable of driving most types of LEDs with forward voltages as high as 4.7V at full current with a VCC input supply of 2.8V to 5.5V.

The Evaluation Board contains a standard 5-pin terminal connector to allow the user to easily interface with the microcontroller and the ZLED7012 to evaluate its functions, features, and performance. The Evaluation Board also has two push-buttons to send commands and change the operation mode of the ZLED7012.

Figure 2.1 shows the top view of the populated kit PCB.

2.2. Power Supply

For easy operation with a 5V supply, the on-board female USB Mini-B connector K1 can be connected via the enclosed cable to a USB A connector of a PC or USB power supply.

To operate the kit over the whole supply voltage range of 2.8V to 5.5V, an external power supply can be connected to the Vdd and GND pins of the K2 header.

Since the product family members ZLED7012 and ZLED7022 use the same kit PCB differing only in the number of current channels, the red power indicator LED D11 (for the ZLED7012KIT-E1 Evaluation Kit) or D12 (for the ZLED7022KIT-E1 Evaluation Kit) will automatically point to the valid kit type when power is attached.

Evaluation Kit December 8, 2010	© 2010 Zentrum Mikroelektronik Dresden AG — Rev. 1.0 All rights reserved. The material contained herein may not be reproduced, adapted, merged, translated, stored, or used without the prior written consent of the copyright owner. The information furnished in this publication is subject to changes without notice.	3 of 7
------------------------------------	--	--------

ZLED7012
 ZLED7012KIT-E1 Evaluation Kit



Figure 2.1 ZLED7012KIT-E1 Evaluation Board (Top View)

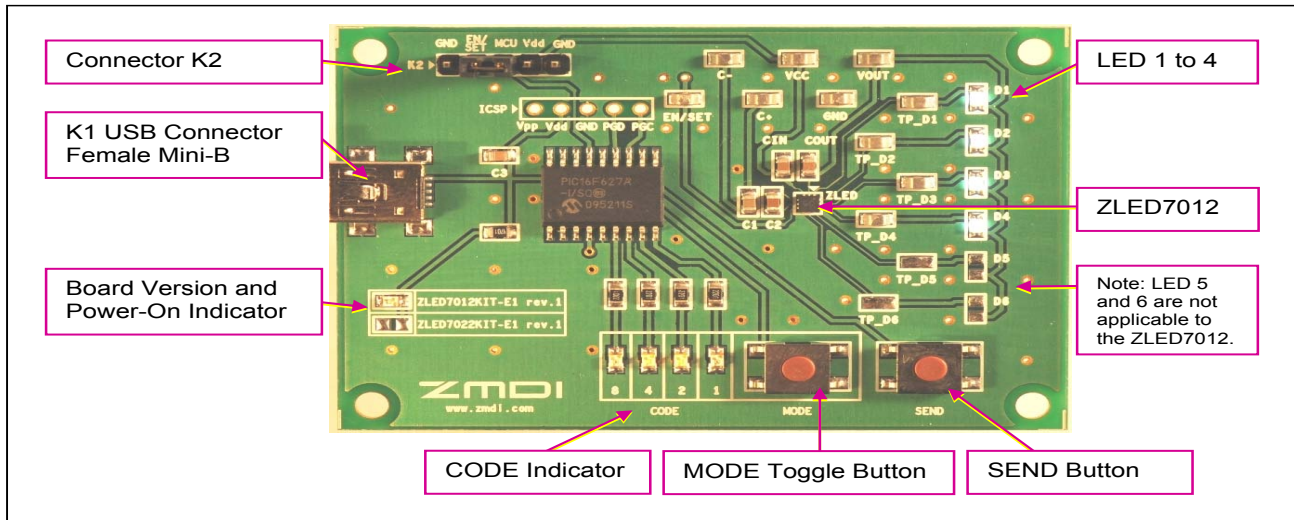

2.3. Interface and Setting Options

K1 – Female USB Mini-B connector for USB power supply. Data pins are not connected.

K2 – Header with the following pins:

- 1 – GND Ground. Sets the ZLED7012 to the low current shut-down mode when connected to pin 2 for longer than 500ms.
- 2 – EN/SET PCC programming input of the ZLED7012. Can be connected to an external pulse generator or to pin 3 to use the on-board pulse generator or to pin 1 to set ZLED7012 to the low-current shut-down mode.
- 3 – MCU Pulse code sequence output of the microcomputer.
- 4 – Vdd External supply voltage of 2.8V to 5.5V.
- 5 – GND Ground.

ICSP – Contact pads of the microcomputer programming interface.

MODE button – Toggles the PCC pulse count number.

SEND button – Programs the PCC pulse count number to the ZLED7012.

CODE indicator LEDs – Indicates preset PCC pulse count number in hex code.

Test pins – Provide access to all I/Os of the ZLED7012.

LEDs D1 to D4 – Driven by ZLED7012's outputs D0 to D3.

(Note the difference in denotation for LED numbers between the ZLED7012 and the Evaluation Board LEDs.)

Evaluation Kit December 8, 2010	© 2010 Zentrum Mikroelektronik Dresden AG — Rev. 1.0 All rights reserved. The material contained herein may not be reproduced, adapted, merged, translated, stored, or used without the prior written consent of the copyright owner. The information furnished in this publication is subject to changes without notice.	4 of 7
------------------------------------	--	--------

ZLED7012
 ZLED7012KIT-E1 Evaluation Kit



2.4. Demo Mode

To run the demo mode, the EN/SET and MCU pins of the header K2 must be connected by a jumper (the factory-default jumper position on delivery). After the power-on and the microcomputer initialization are completed, the CODE LEDs indicate the number 0xF with all four yellow LEDs glowing. Starting with the highest current level, the pulse count is continuously incremented by the microcomputer and programmed into the ZLED7012 after a hold time of about 0.5 seconds on each brightness level. The firmware of the microcomputer generates programming pulses of about 20µs duration.

2.5. Manual Mode

When the jumper connects the EN/SET and MCU pins on K2, consecutively pressing the MODE button will toggle the PCC pulse count to the corresponding hex code in the µC. This number is displayed by the CODE indicator LEDs. After the desired value is reached, pressing the SEND button programs the preset pulse sequence into the ZLED7012 and changes the current level according to Table 2.1.

Entering 0x0 causes the µC to hold the EN/SET signal at low potential for more than 500ms, which switches the ZLED7012 into the shut-off mode. Entering 0xF restarts the demo mode.

With the jumper on the K2 header removed, an external PCC sequence source can be connected between the EN/SET and GND pins. For signal levels and timing, refer to the data sheet.

Table 2.1 Current Output Settings

PCC Pulse Count	Hex CODE Display	Current Output per Channel (mA)
-	0x0	Causes the µC to hold the EN/SET input at low potential for longer than 500 ms, which will set the IC into the shut-off mode.
1	0x1	20.0
2	0x2	17.0
3	0x3	14.0
4	0x4	12.0
5	0x5	10.0
6	0x6	8.6
7	0x7	7.0
8	0x8	6.0
9	0x9	5.0
10	0xA	4.2
11	0xB	3.6
12	0xC	3.0
13	0xD	2.4
14	0xE	1.8
-	0xF	Not part of the code range of the ZLED7012. Will cause the µC to start the demo mode.

ZLED7012
 ZLED7012KIT-E1 Evaluation Kit



2.6. Schematic Diagram

Figure 2.2 ZLED7012KIT-E1 Schematic Diagram

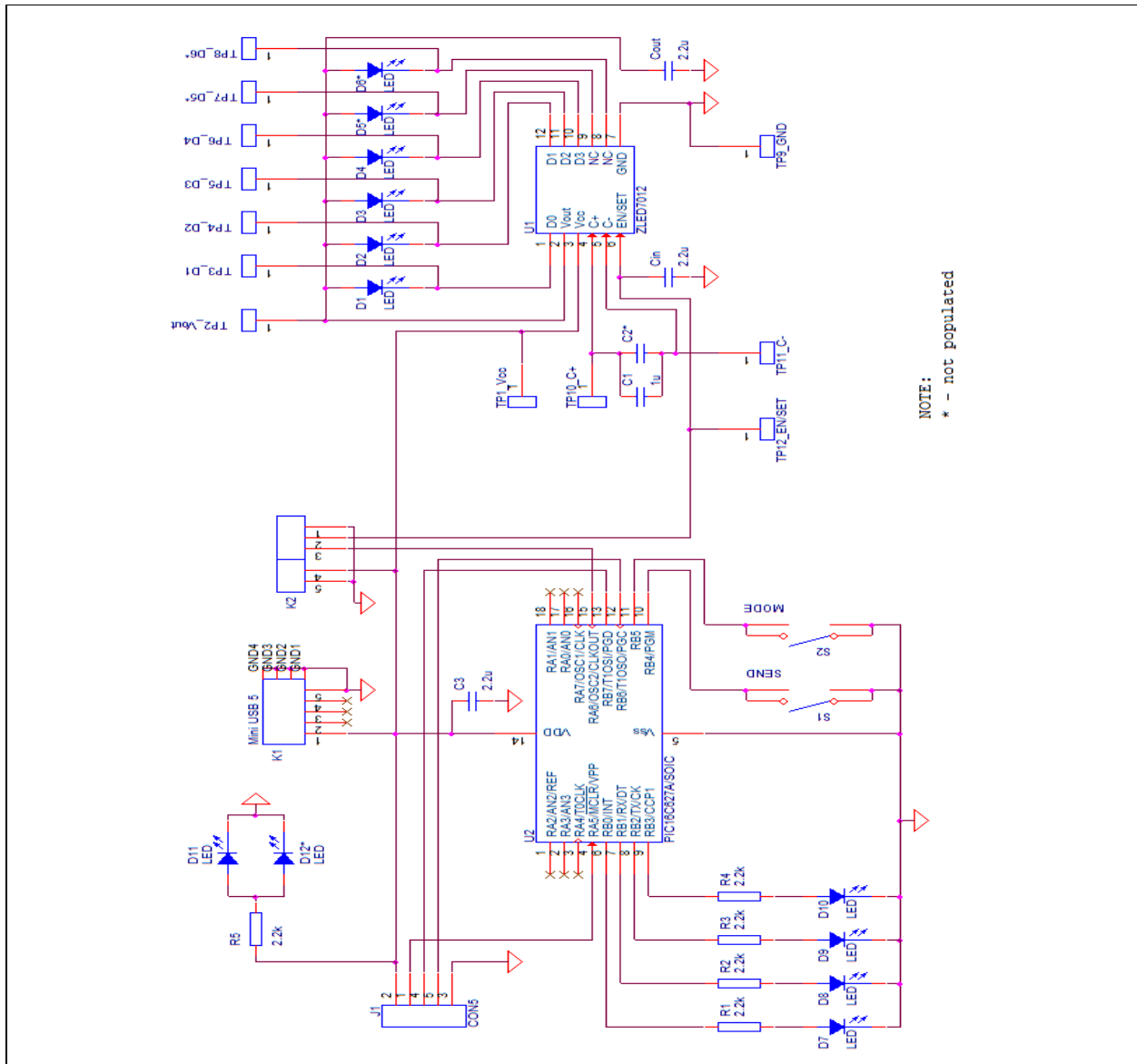

NOTE:
 * - not populated

ZLED7012

ZLED7012KIT-E1 Evaluation Kit

ZMDI[®]
The Analog Mixed Signal Company



3 Ordering Information

Product Sales Code	Description
ZLED7012KIT-E1	ZLED7012KIT-E1 Evaluation Kit V1.0 incl. USB cable and 5 IC samples

4 Related Documents

Document	File Name
ZLED7012 Datasheet	ZLED7012_DataSheet_Rev_X.x.pdf

Visit ZMDI's website www.zmdi.com or contact your nearest sales office for the latest version of these documents.

5 Glossary

Term	Description
ICSP	In Circuit Serial Programming
μC	Microcontroller
PCB	Printed Circuit Board
USB	Universal Serial Bus

6 Document Revision History

Revision	Date	Description
1.0	December 8, 2010	Initial release

Sales and Further Information		www.zmdi.com	LED_drivers@zmdi.com
Zentrum Mikroelektronik Dresden AG Grenzstrasse 28 01109 Dresden Germany Phone +49 (0)351.8822.7.533 Fax +49 (0)351.8822.8.7533	ZMD America, Inc. 8413 Excelsior Drive Suite 200 Madison, WI 53717 USA Phone +1 (608) 829-1987 Fax +1 (631) 549-2882	Zentrum Mikroelektronik Dresden AG, Japan Office 2nd Floor, Shinbashi Tokyu Bldg. 4-21-3, Shinbashi, Minato-ku Tokyo, 105-0004 Japan Phone +81.3.6895.7410 Fax +81.3.6895.7301	ZMD FAR EAST, Ltd. 3F, No. 51, Sec. 2, Keelung Road 11052 Taipei Taiwan Phone +886 2 2377 8189 Fax +886 2 2377 8199
<small>DISCLAIMER: This information applies to a product under development. Its characteristics and specifications are subject to change without notice. Zentrum Mikroelektronik Dresden AG (ZMD AG) assumes no obligation regarding future manufacture unless otherwise agreed to in writing. The information furnished hereby is believed to be true and accurate. However, under no circumstances shall ZMD AG be liable to any customer, licensee, or any other third party for any special, indirect, incidental, or consequential damages of any kind or nature whatsoever arising out of or in any way related to the furnishing, performance, or use of this technical data. ZMD AG hereby expressly disclaims any liability of ZMD AG to any customer, licensee or any other third party, and any such customer, licensee and any other third party hereby waives any liability of ZMD AG for any damages in connection with or arising out of the furnishing, performance or use of this technical data, whether based on contract, warranty, tort (including negligence), strict liability, or otherwise.</small>			
Evaluation Kit December 8, 2010	<small>© 2010 Zentrum Mikroelektronik Dresden AG — Rev. 1.0 All rights reserved. The material contained herein may not be reproduced, adapted, merged, translated, stored, or used without the prior written consent of the copyright owner. The information furnished in this publication is subject to changes without notice.</small>		7 of 7

Mouser Electronics

Authorized Distributor

Click to View Pricing, Inventory, Delivery & Lifecycle Information:

ZMDI:

ZLED7012Kit-E1